



US00D590685S

(12) **United States Design Patent**  
**Sterling**

(10) **Patent No.:** **US D590,685 S**

(45) **Date of Patent:** **\*\* Apr. 21, 2009**

(54) **CLUTCH HOUSING FOR PNEUMATIC TOOL**

*Primary Examiner*—Antoine D Davis

(75) **Inventor:** **Robert E. Sterling**, Colbert, WA (US)

(74) *Attorney, Agent, or Firm*—Christensen O'Connor Johnson Kindness PLLC

(73) **Assignee:** **Exhaust Technologies, Inc.**, Spokane, WA (US)

(57) **CLAIM**

(\*\*) **Term:** **14 Years**

The ornamental design for a clutch housing for pneumatic tool, as shown and described.

(21) **Appl. No.:** **29/317,525**

(22) **Filed:** **Apr. 30, 2008**

**DESCRIPTION**

(51) **LOC (9) Cl.** ..... **08-05**

(52) **U.S. Cl.** ..... **D8/70; D15/140**

(58) **Field of Classification Search** ..... D8/61-70;  
D15/140; 279/60-66, 157, 901, 902; 408/56,  
408/240

FIG. 1 is a perspective view of a clutch housing for pneumatic tool of my design, showing in phantom other portions of a hand tool that are not a part of the present design;

FIG. 2 is an upper, right-front perspective view of the clutch housing for pneumatic tool shown in FIG. 1;

See application file for complete search history.

FIG. 3 is an upper, right-back perspective view of the clutch housing for pneumatic tool shown in FIG. 1;

(56) **References Cited**

**U.S. PATENT DOCUMENTS**

D404,629	S	*	1/1999	Cooper	.....	D8/70
D404,630	S	*	1/1999	Cooper	.....	D8/70
D409,210	S	*	5/1999	Cooper	.....	D15/140
D434,630	S	*	12/2000	Oliver et al.	.....	D8/83
D556,002	S	*	11/2007	Ino	.....	D8/68
D581,762	S	*	12/2008	Aglassinger	.....	D8/68
D582,740	S	*	12/2008	Weinberg et al.	.....	D8/68

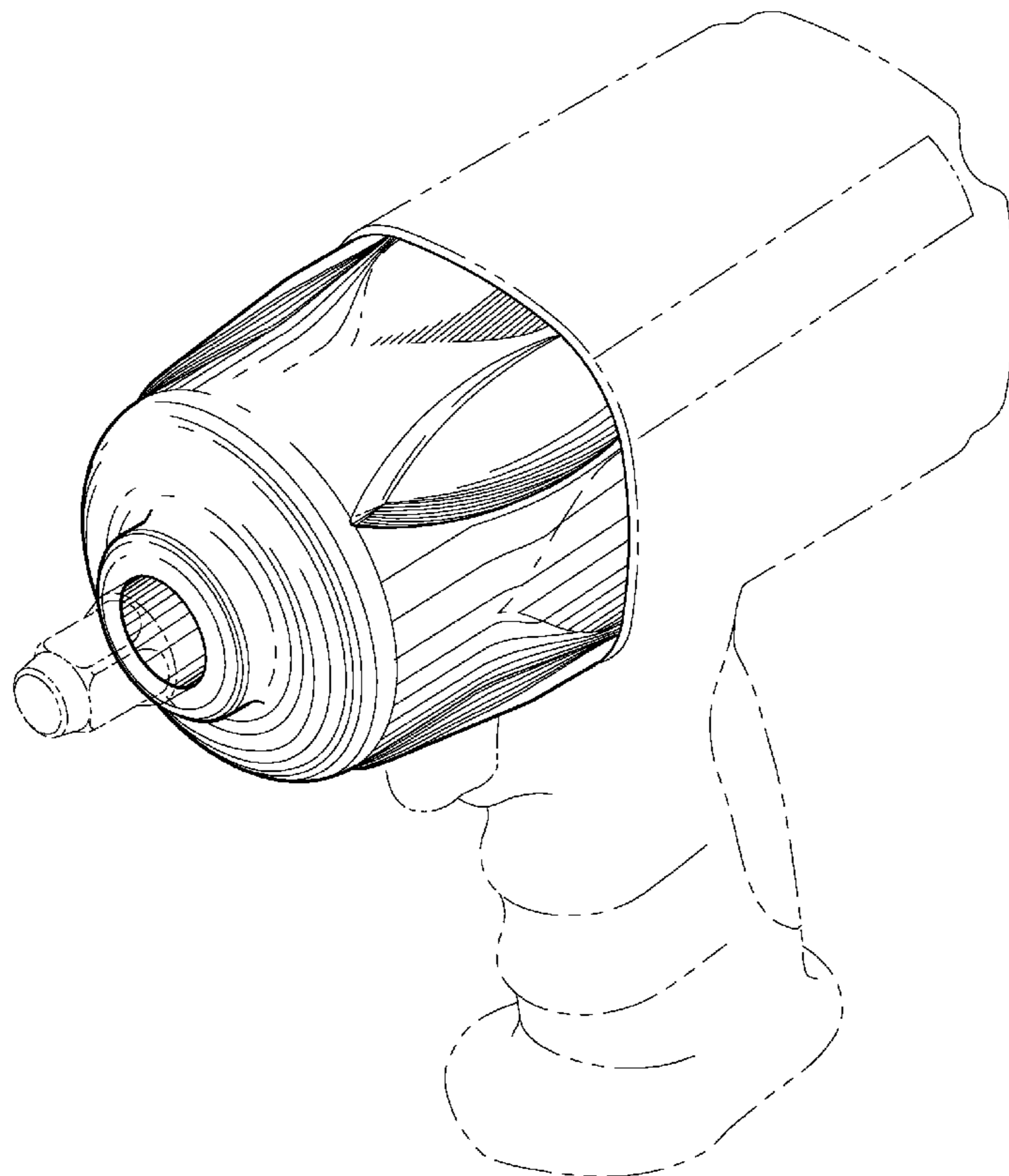
FIG. 4 is a right side view of the clutch housing for pneumatic tool shown in FIG. 1, which due to symmetry is the same as the left side, top and bottom views of the clutch housing for pneumatic tool;

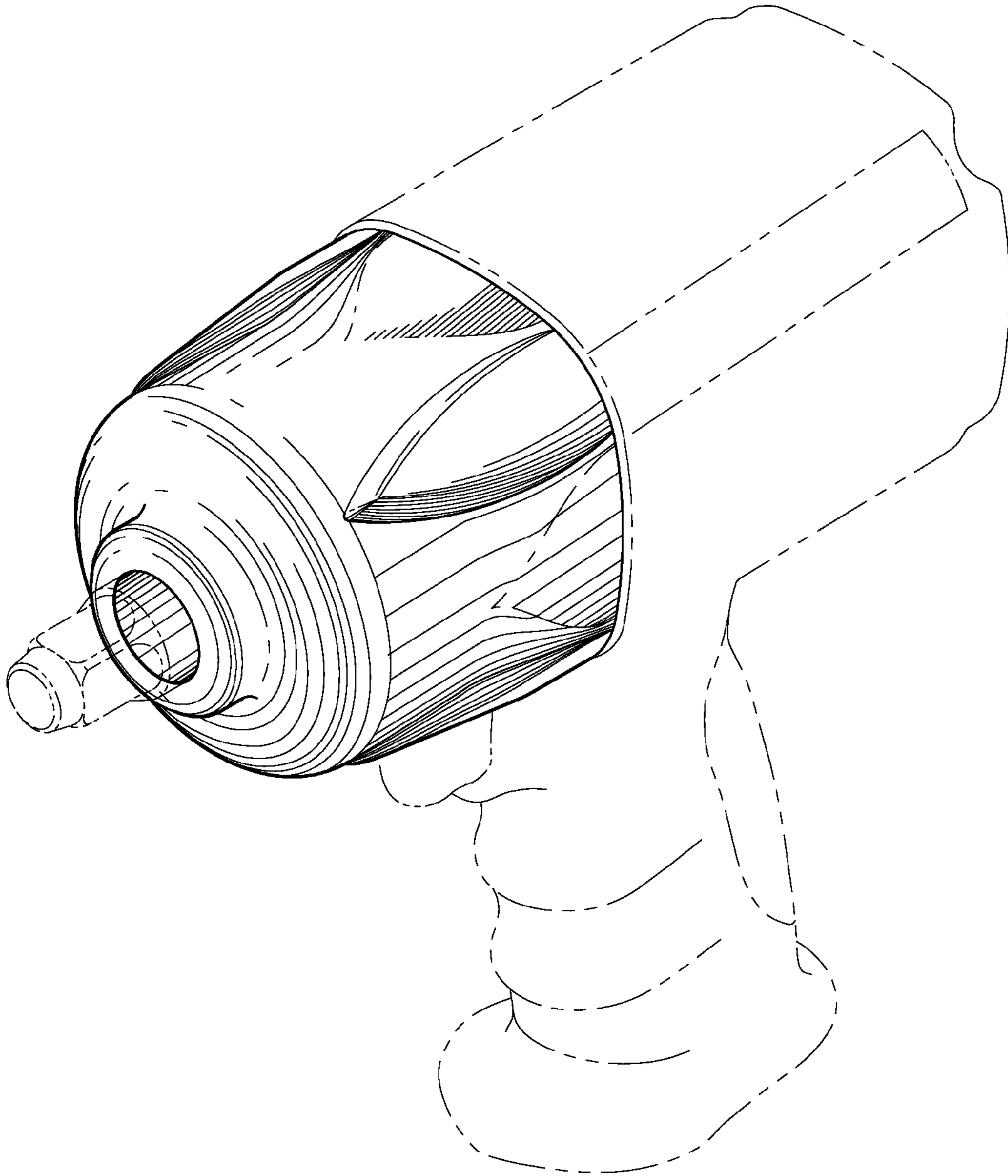
FIG. 5 is a front view of the clutch housing for pneumatic tool shown in FIG. 1; and,

FIG. 6 is a back view of the clutch housing for pneumatic tool shown in FIG. 1.

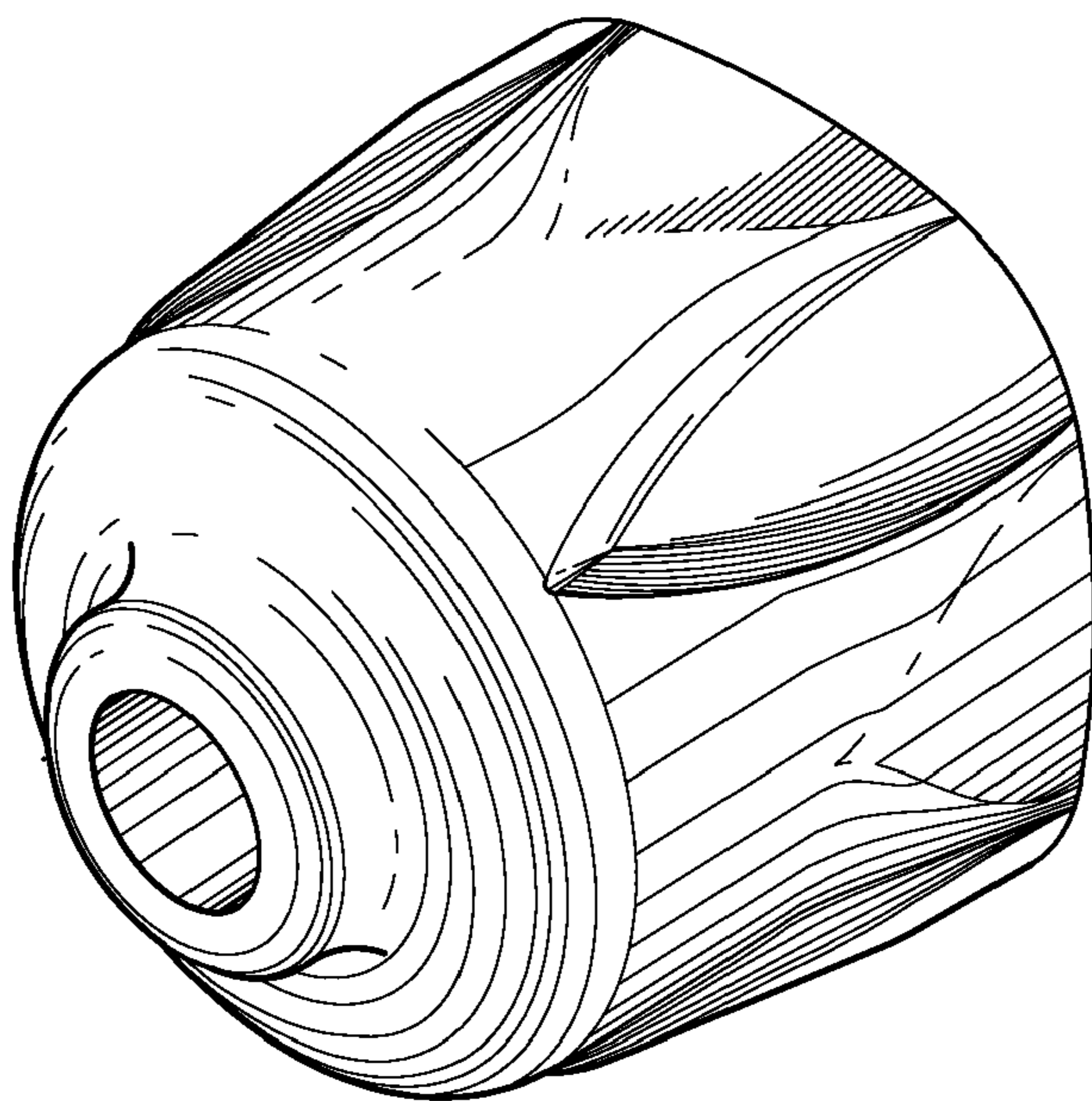
\* cited by examiner

**1 Claim, 3 Drawing Sheets**

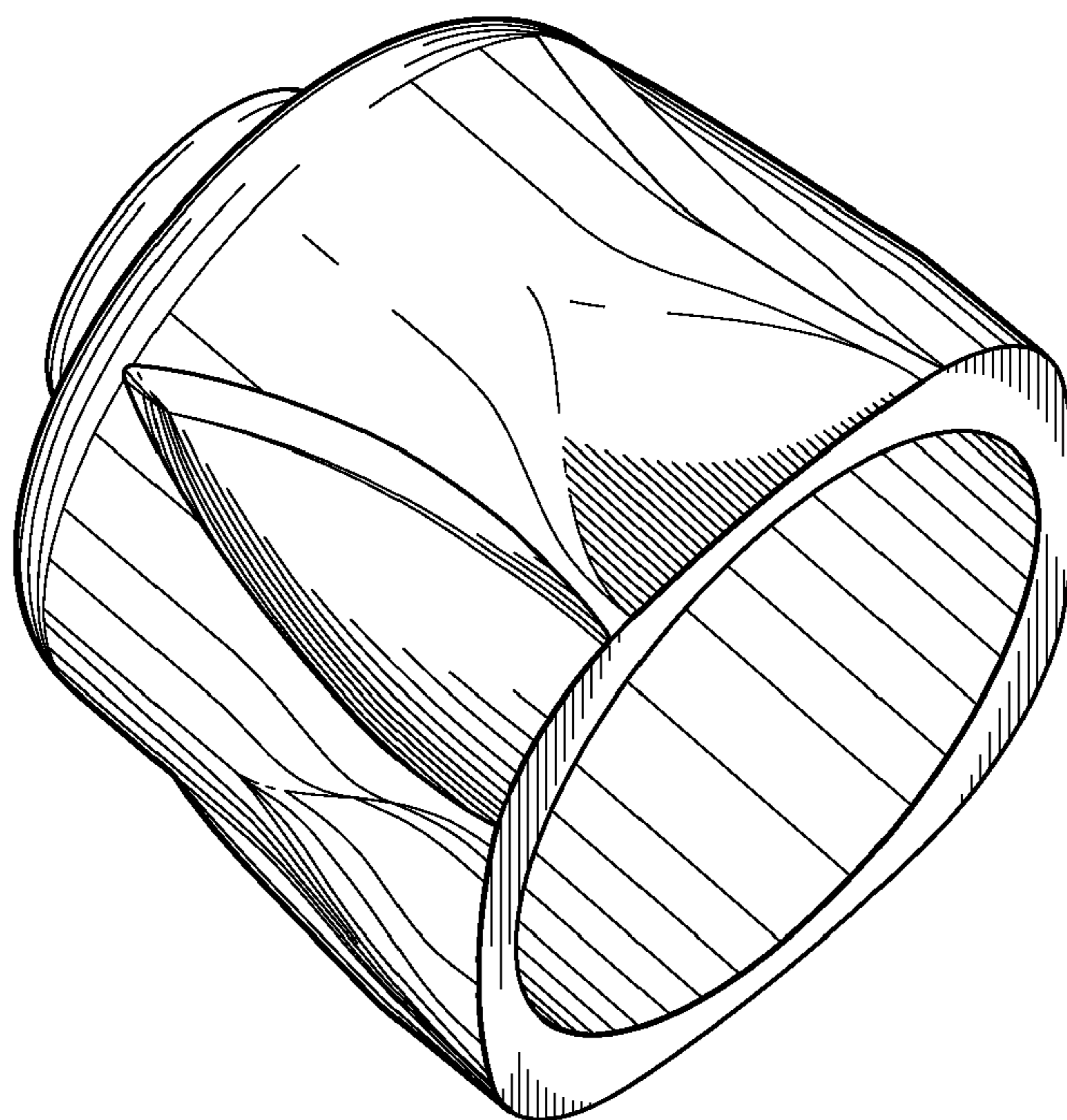




***Fig. 1.***



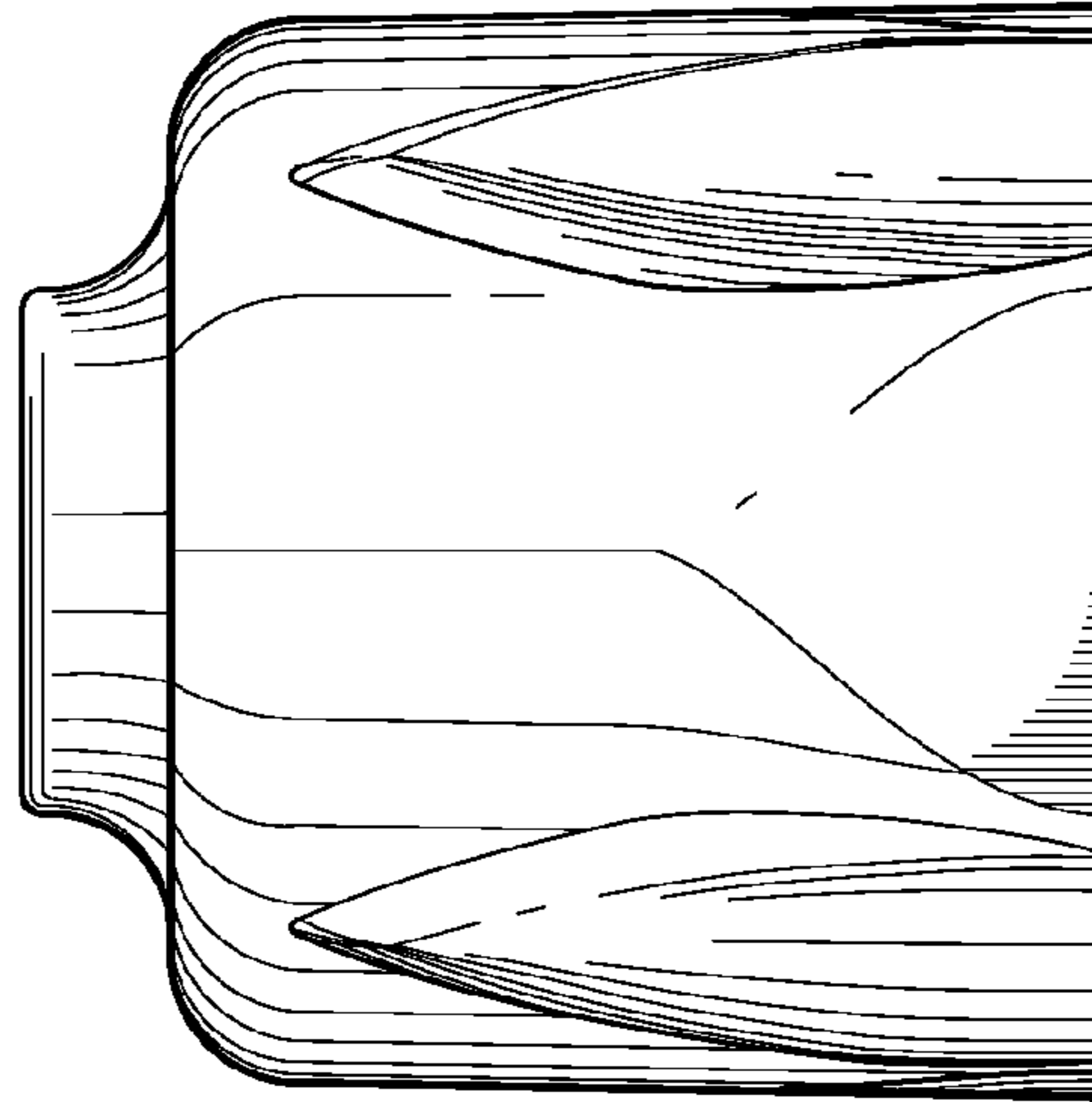
*Fig. 2.*



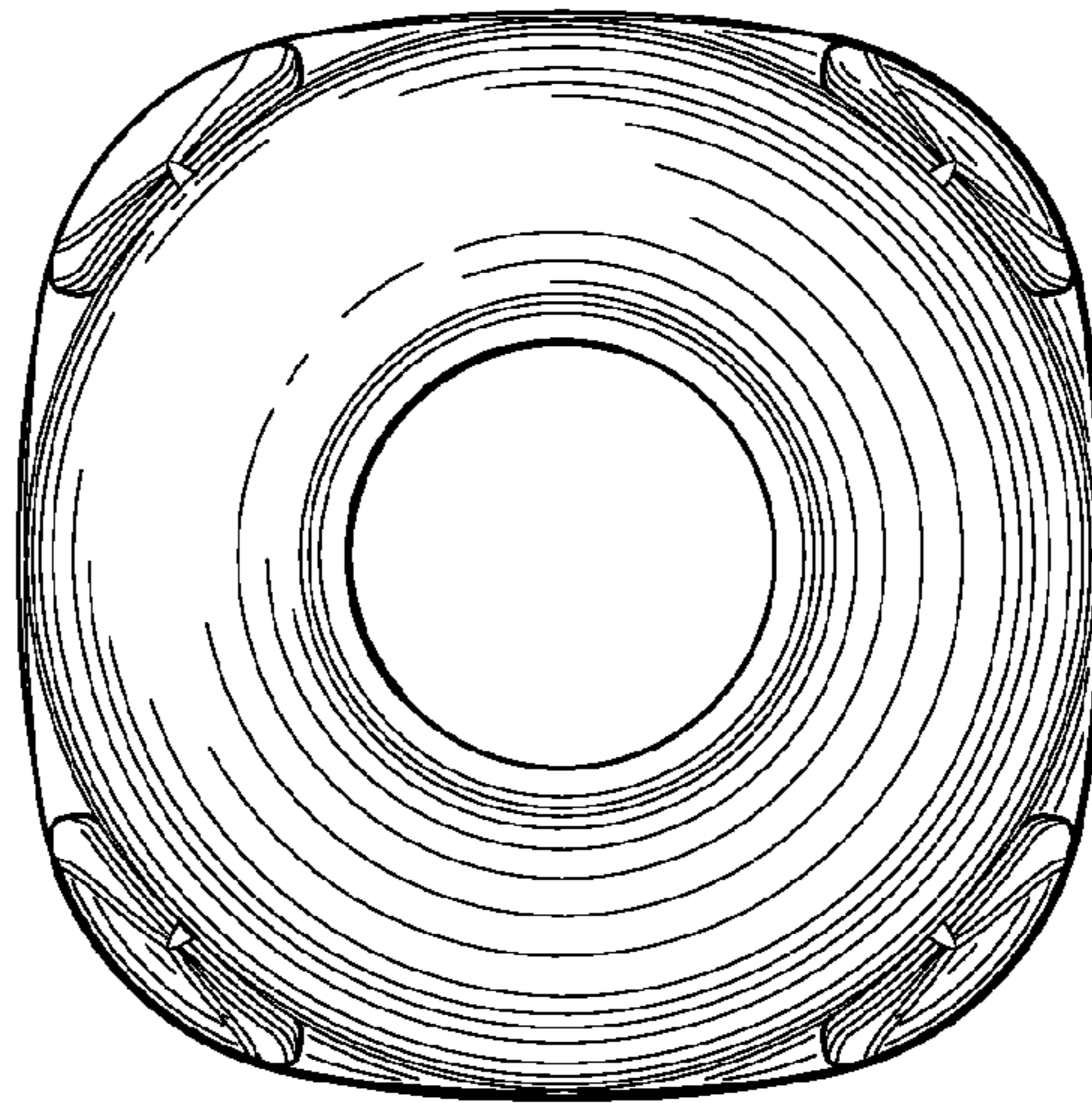
*Fig. 3.*



*Fig. 4.*



*Fig. 5.*



*Fig. 6.*

