



US00D590332S

(12) **United States Design Patent**  
**Sato**

(10) **Patent No.:** **US D590,332 S**  
(45) **Date of Patent:** **\*\* Apr. 14, 2009**

(54) **AUTOMOBILE TIRE**

- (75) Inventor: **Yoshiki Sato**, Osaka (JP)
- (73) Assignee: **Toyo Tire & Rubber Co., Ltd.**, Osaka (JP)
- (\*\*) Term: **14 Years**
- (21) Appl. No.: **29/327,750**
- (22) Filed: **Nov. 12, 2008**

(30) **Foreign Application Priority Data**

Oct. 7, 2008 (JP) ..... 2008-025742

- (51) **LOC (9) Cl.** ..... **12-15**
- (52) **U.S. Cl.** ..... **D12/605**
- (58) **Field of Classification Search** ..... D12/500–501, D12/544, 579, 600, 605; 152/523–524, DIG. 12, 152/555; D7/570–576  
See application file for complete search history.

(56) **References Cited**

**U.S. PATENT DOCUMENTS**

D565,504 S	*	4/2008	Tanaka	.....	D12/605
D569,336 S	*	5/2008	Onoe	.....	D12/605
D569,791 S	*	5/2008	Iwabuchi et al.	.....	D12/605
D574,766 S	*	8/2008	Iwabuchi et al.	.....	D12/605
D576,544 S	*	9/2008	Onoe	.....	D12/605
D584,682 S	*	1/2009	Tanaka	.....	D12/605

**FOREIGN PATENT DOCUMENTS**

JP D1331370 S 5/2008

\* cited by examiner

*Primary Examiner*—Stacia Cadmus

(74) *Attorney, Agent, or Firm*—Westerman, Hattori, Daniels & Adrian, LLP.

(57) **CLAIM**

The ornamental design for an automobile tire, as shown and described.

**DESCRIPTION**

FIG. 1 is a front, elevation view of the automobile tire;  
 FIG. 2 is a rear, elevation view of the automobile tire;  
 FIG. 3 is a left-side, elevation view of the automobile tire;  
 FIG. 4 is a top, plan view of the automobile tire;  
 FIG. 5 is a perspective view of the automobile tire;  
 FIG. 6 is an enlarged view of the part A–A2 in FIG. 1; and,  
 FIG. 7 is an enlarged cross-section view taken along the line D1–D2 of FIG. 6 in the part C–C of in FIG. 6 and the part B–B of FIG. 4.

The broken line showing of the tire is included for the purpose of illustrating environment and forms no part of the claimed design.

**1 Claim, 7 Drawing Sheets**

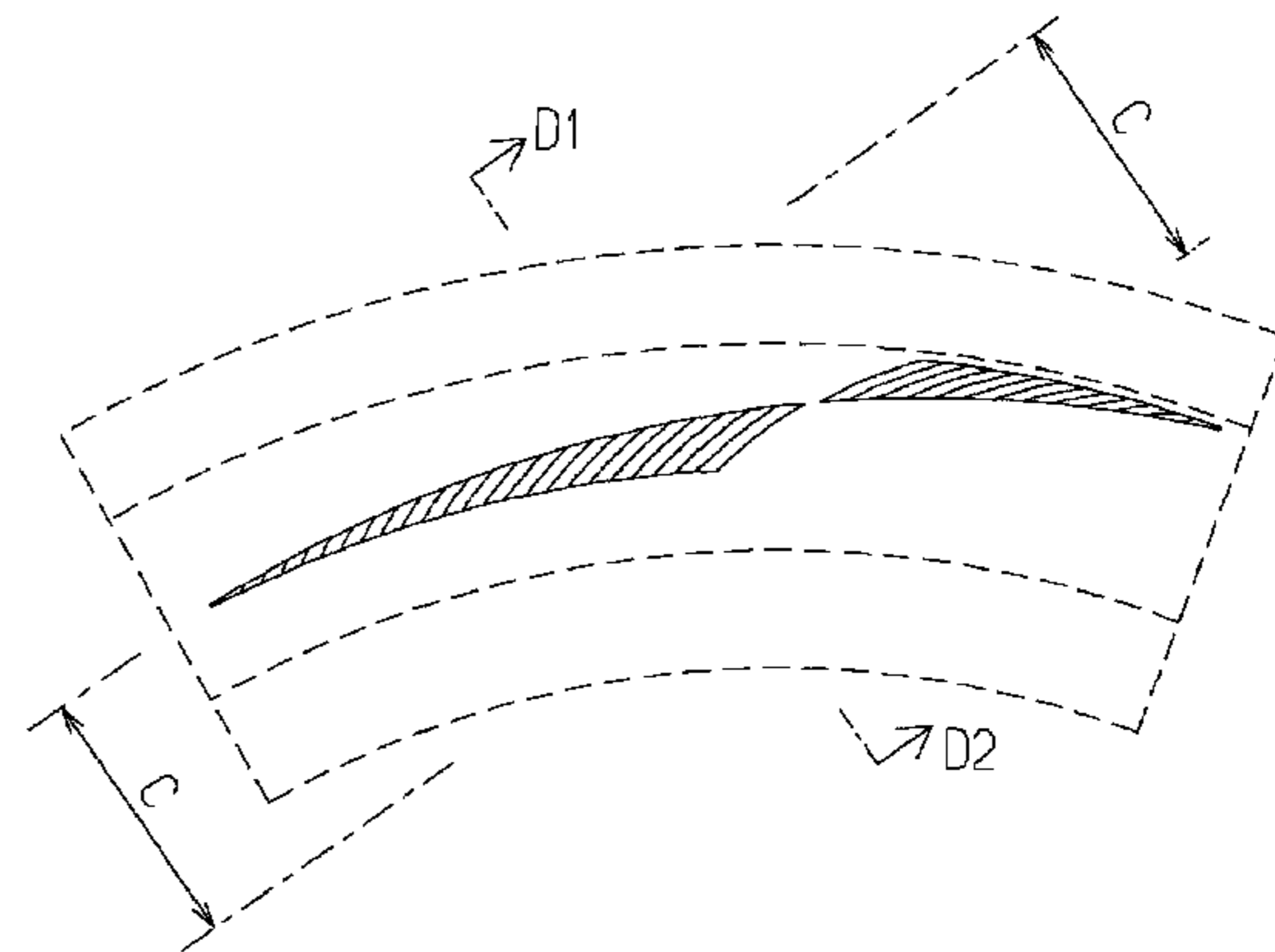
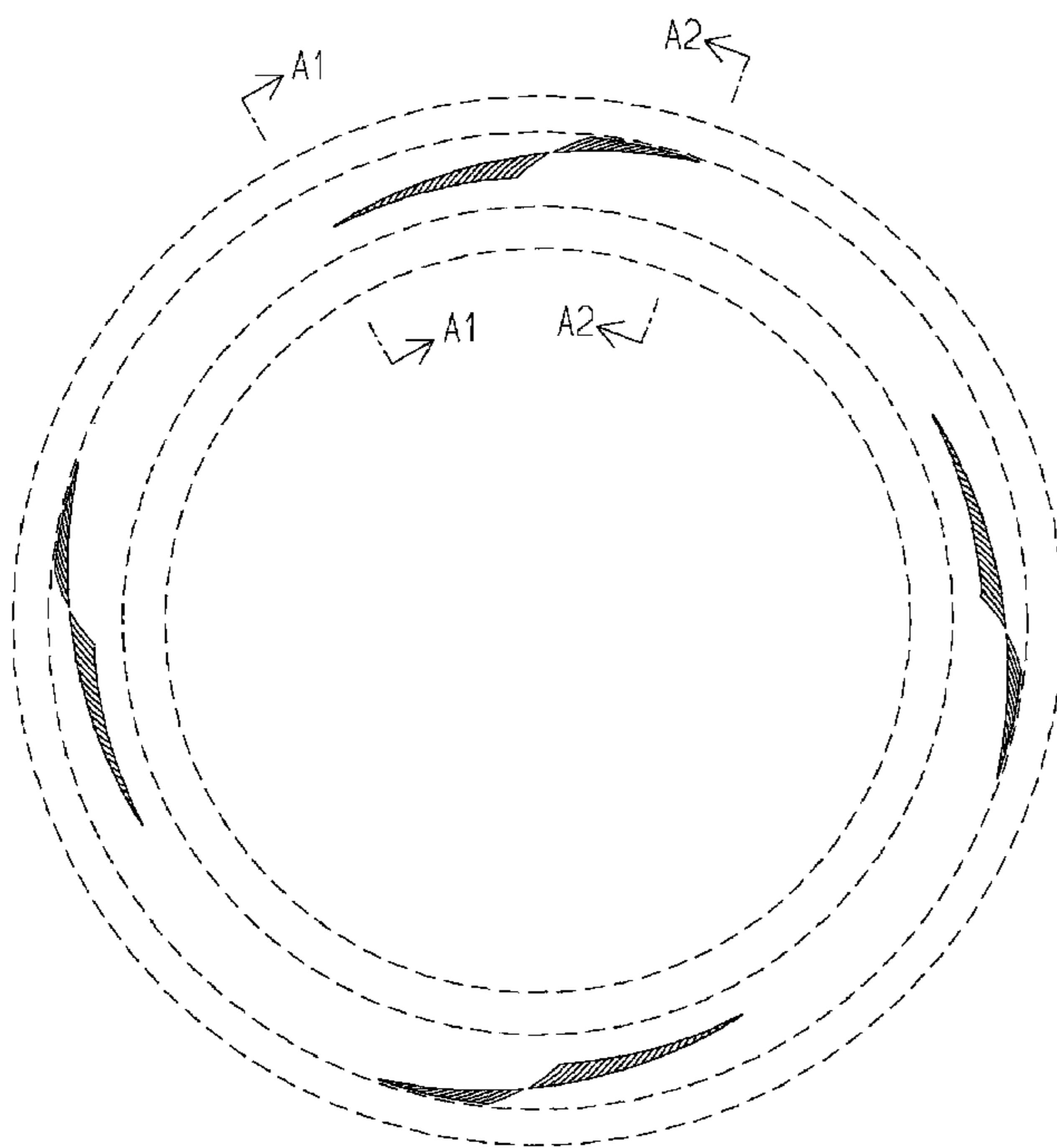

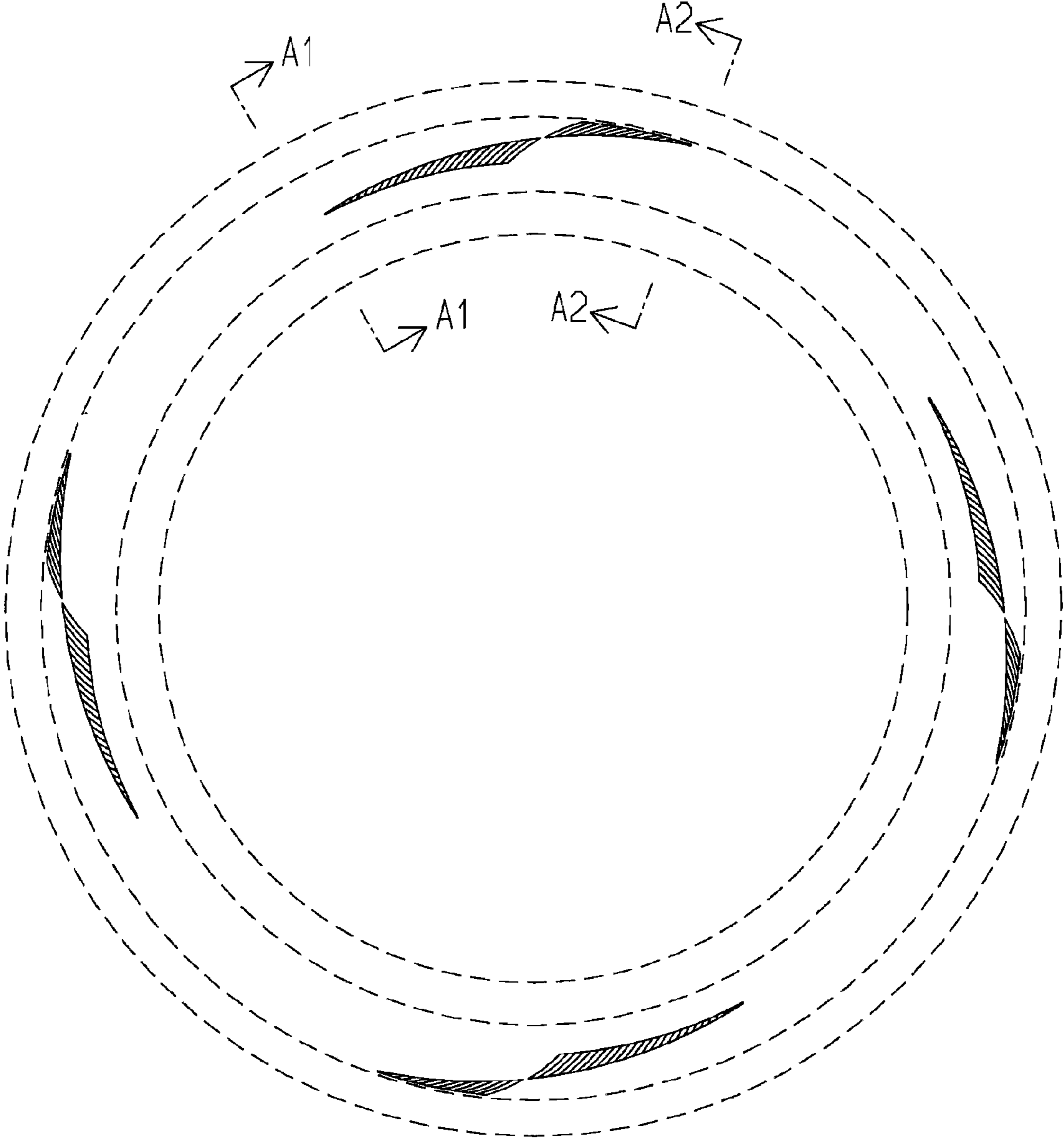

FIG.1

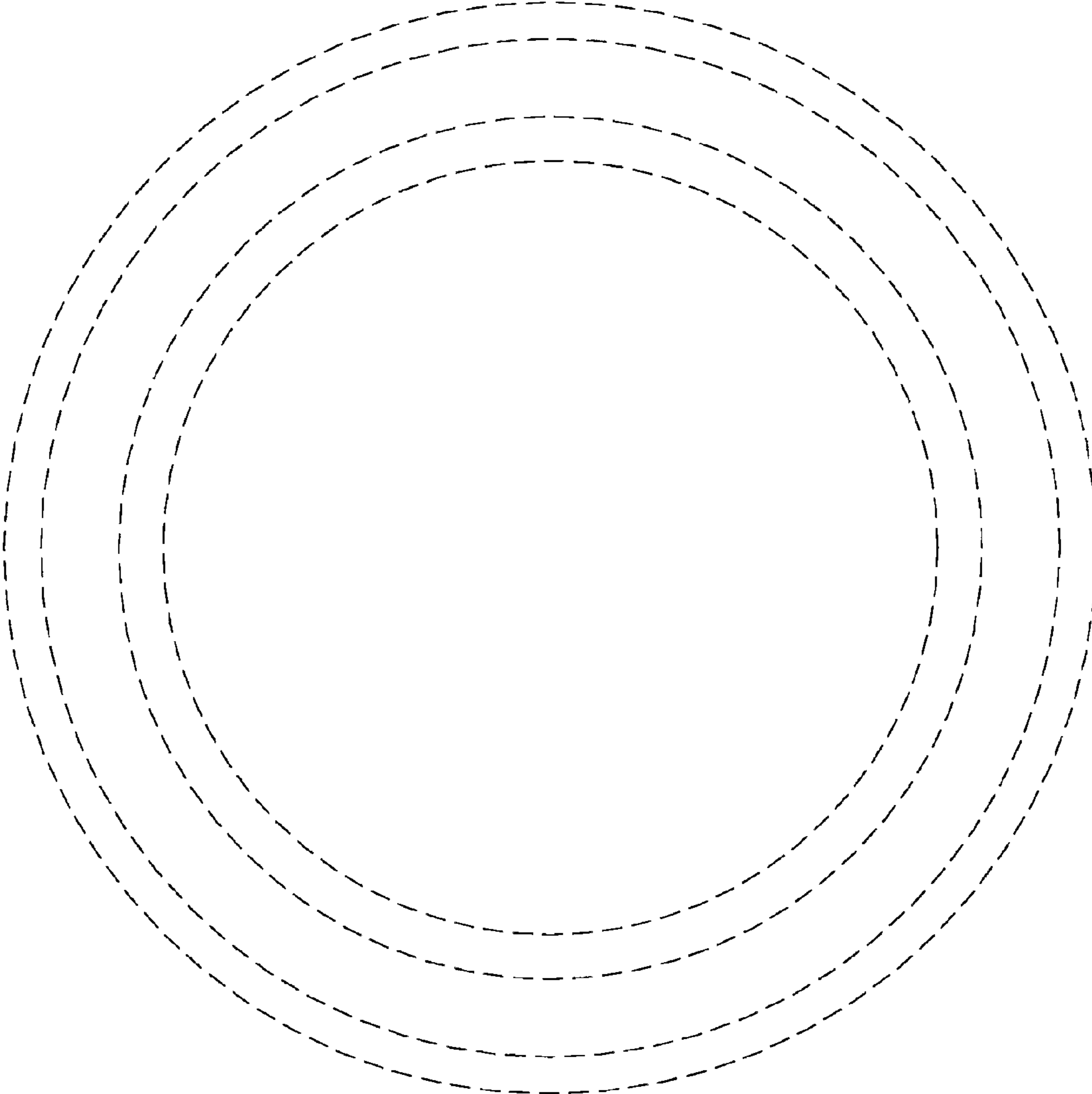

FIG.2

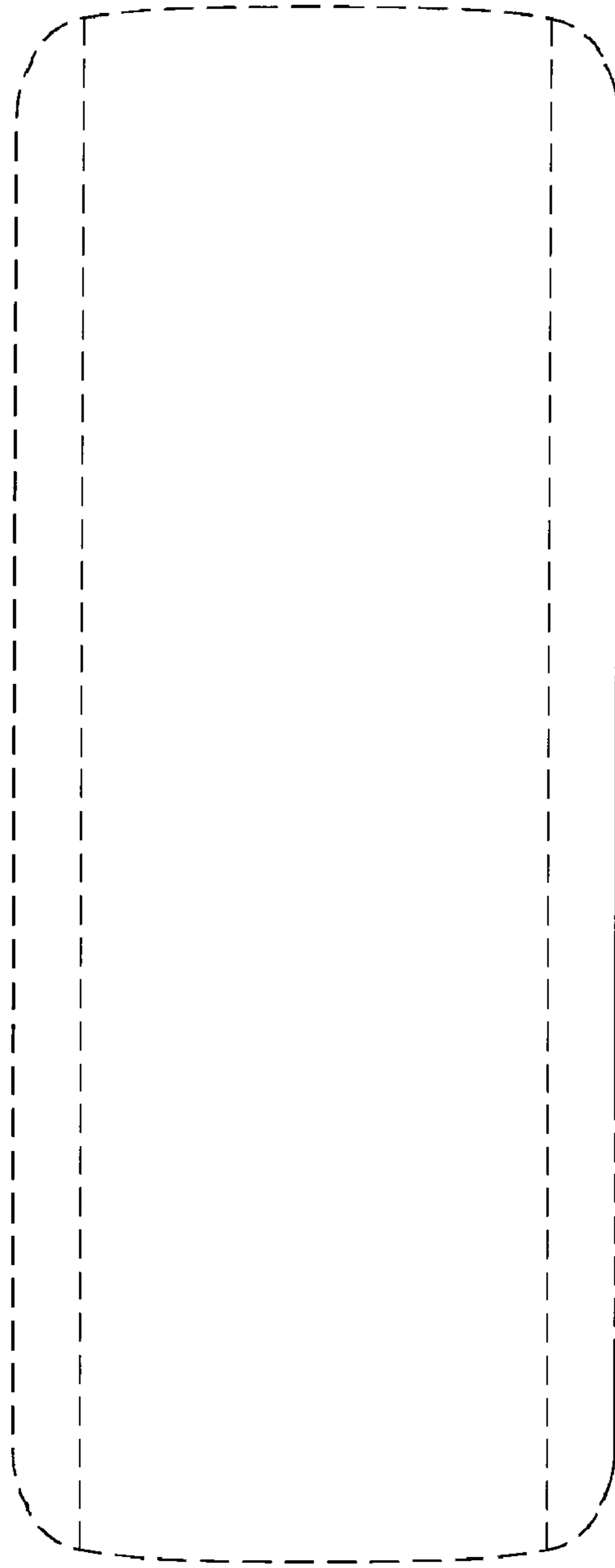

FIG.3

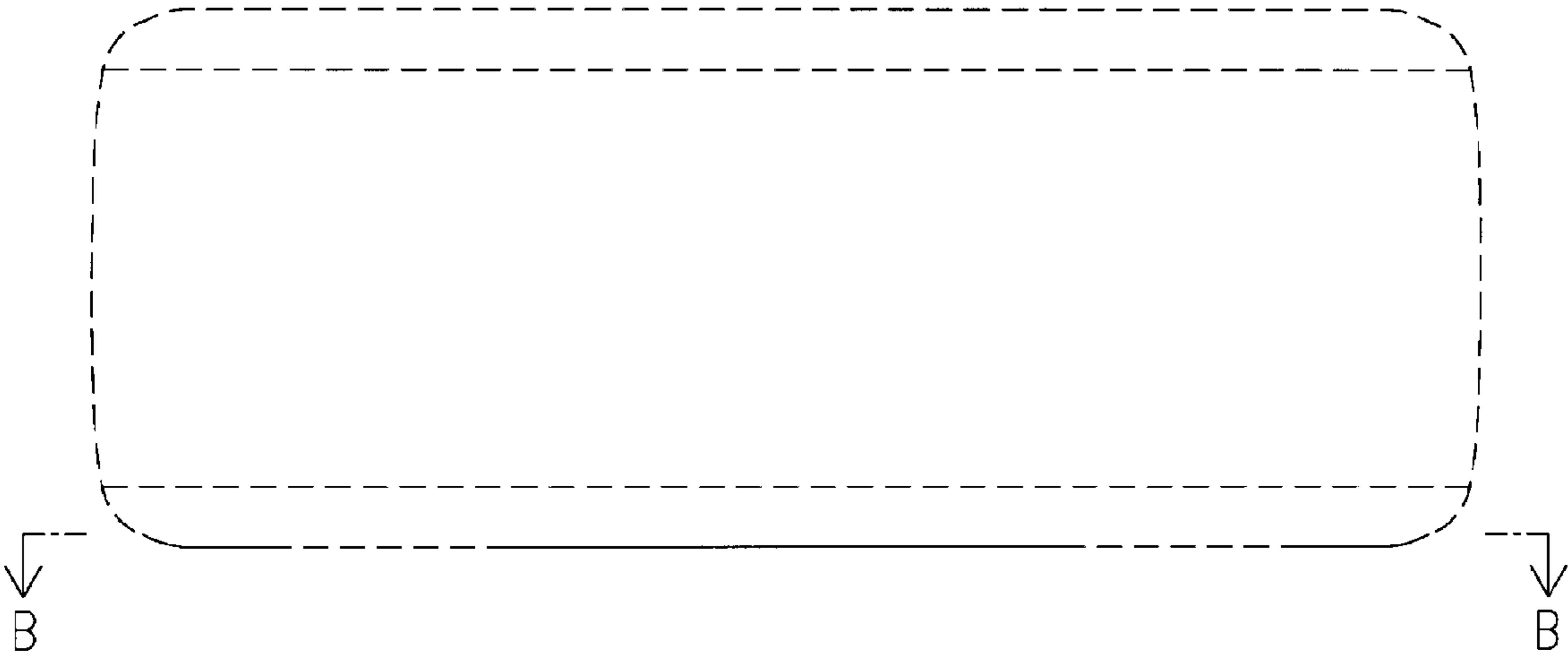

FIG.4

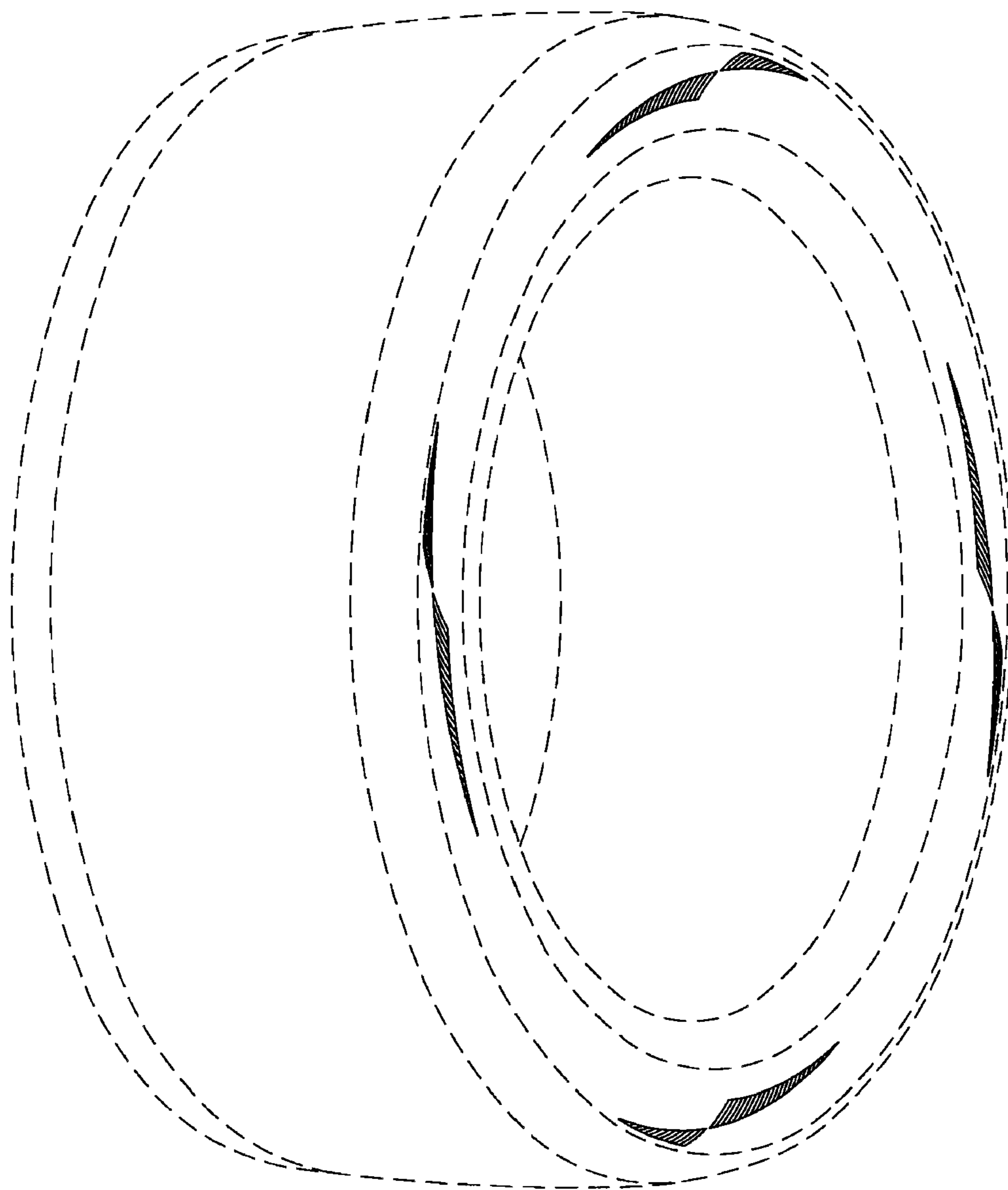

FIG.5

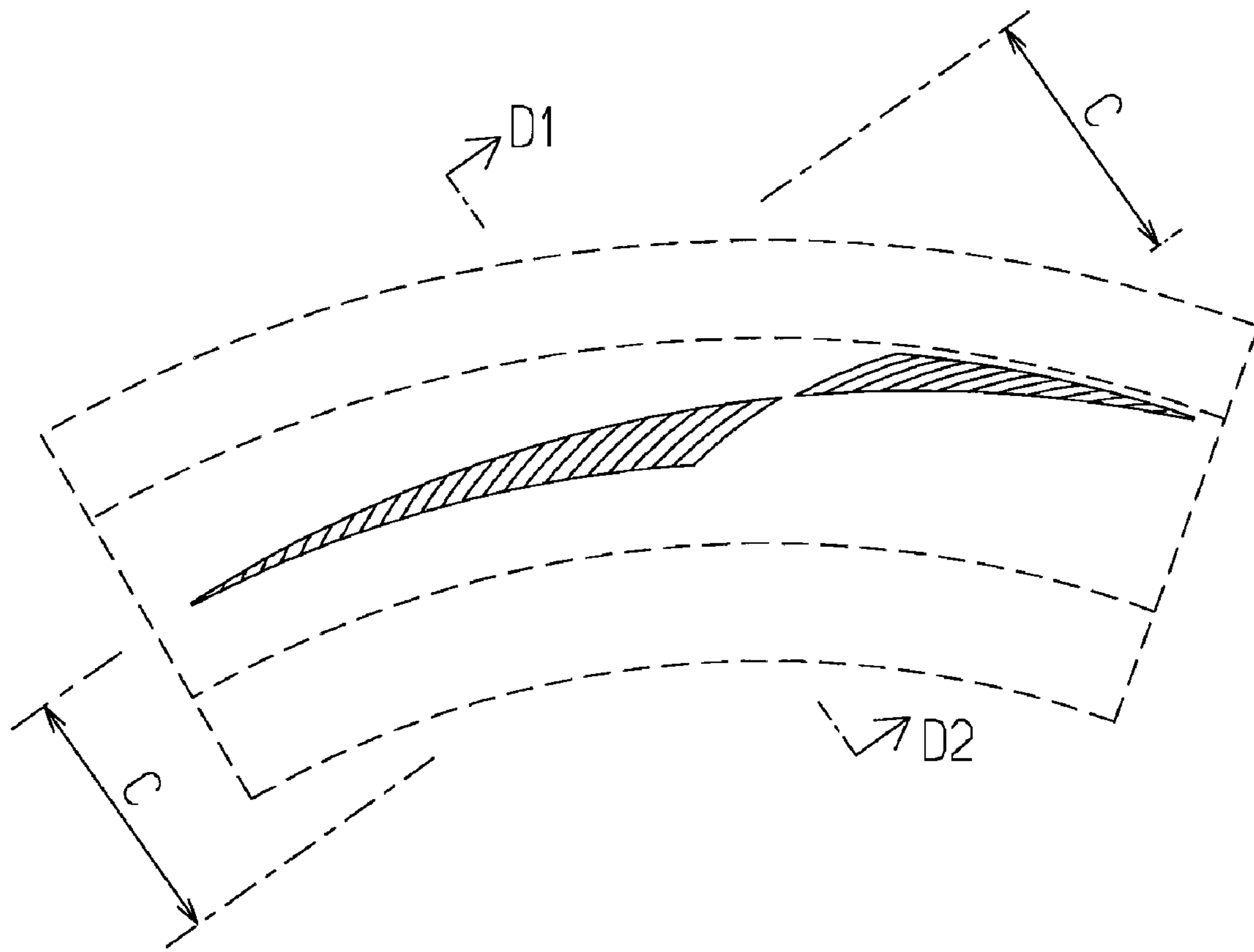
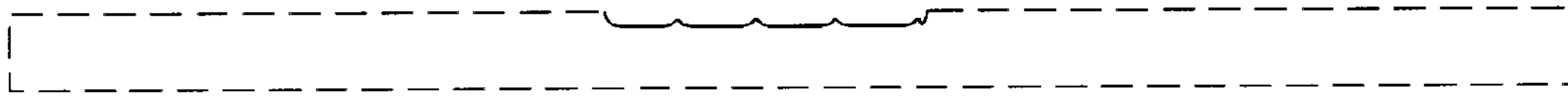

FIG.6



**FIG.7**