



US00D590318S

(12) **United States Design Patent**  
**Theiss**

(10) **Patent No.:** **US D590,318 S**

(45) **Date of Patent:** **\*\* Apr. 14, 2009**

(54) **FRONT FACE OF A VEHICLE WHEEL**

(75) Inventor: **Peter Theiss**, Stuttgart (DE)

(73) Assignee: **Daimler AG**, Stuttgart (DE)

(\*\*) Term: **14 Years**

(21) Appl. No.: **29/290,273**

(22) Filed: **Nov. 13, 2007**

(30) **Foreign Application Priority Data**

May 14, 2007 (EM) ..... 000722376-0004

(51) **LOC (9) Cl.** ..... **12-16**

(52) **U.S. Cl.** ..... **D12/211**

(58) **Field of Classification Search** ..... D12/204–213;  
301/37.101, 64.101, 65, 64.201  
See application file for complete search history.

(56) **References Cited**

**U.S. PATENT DOCUMENTS**

D348,243 S *	6/1994	Echazabal et al. ....	D12/211
D350,932 S *	9/1994	Echazabel et al. ....	D12/211
D380,431 S *	7/1997	Brown et al. ....	D12/209
D438,162 S *	2/2001	Syring ..... ..	D12/211
D483,714 S *	12/2003	Warming ..... ..	D12/211
D499,685 S *	12/2004	Schaefers ..... ..	D12/211

D502,677 S *	3/2005	Baum ..... ..	D12/209
D516,989 S *	3/2006	Baum ..... ..	D12/211
D517,970 S *	3/2006	Pollmann ..... ..	D12/209
D525,932 S *	8/2006	Hettler ..... ..	D12/211
D535,604 S *	1/2007	Markefka ..... ..	D12/211
D548,162 S *	8/2007	Baum ..... ..	D12/211
D558,117 S *	12/2007	Baum ..... ..	D12/211

\* cited by examiner

*Primary Examiner*—Stacia Cadmus

(74) *Attorney, Agent, or Firm*—Crowell & Moring LLP

(57) **CLAIM**

The ornamental design for a front face of a vehicle wheel, as shown and described.

**DESCRIPTION**

FIG. 1 is a front view of a first embodiment of a front face of a vehicle wheel according to my novel design; and

FIG. 2 is a perspective view thereof.

FIG. 3 is a front view of a second embodiment of the front face of a vehicle wheel according to my novel design; and,

FIG. 4 is a perspective view thereof.

The broken line showing of the bolt holes and center cap in the central hub area is included for the purpose of illustrating environment and forms no part of the claimed design.

**1 Claim, 2 Drawing Sheets**

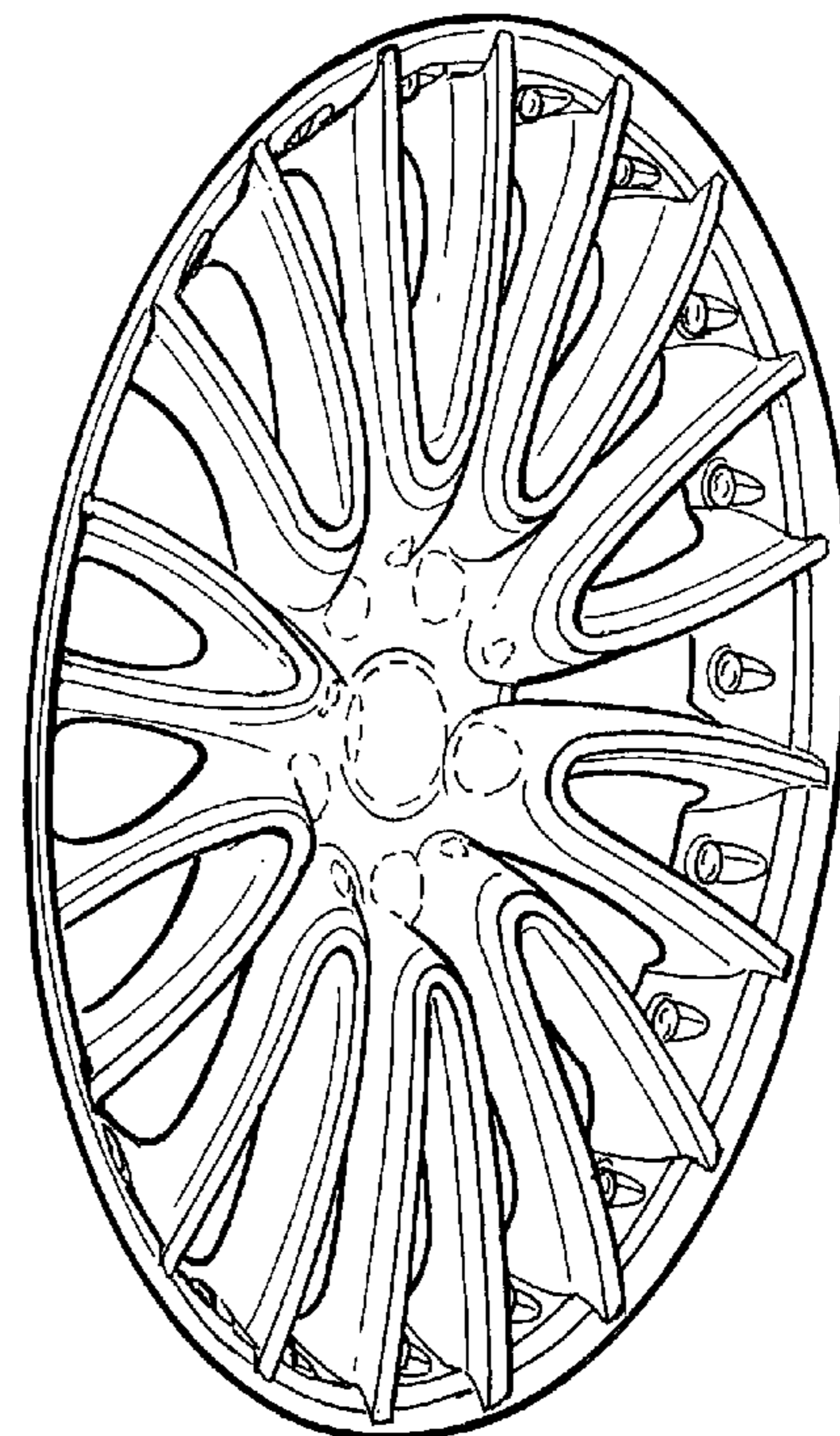
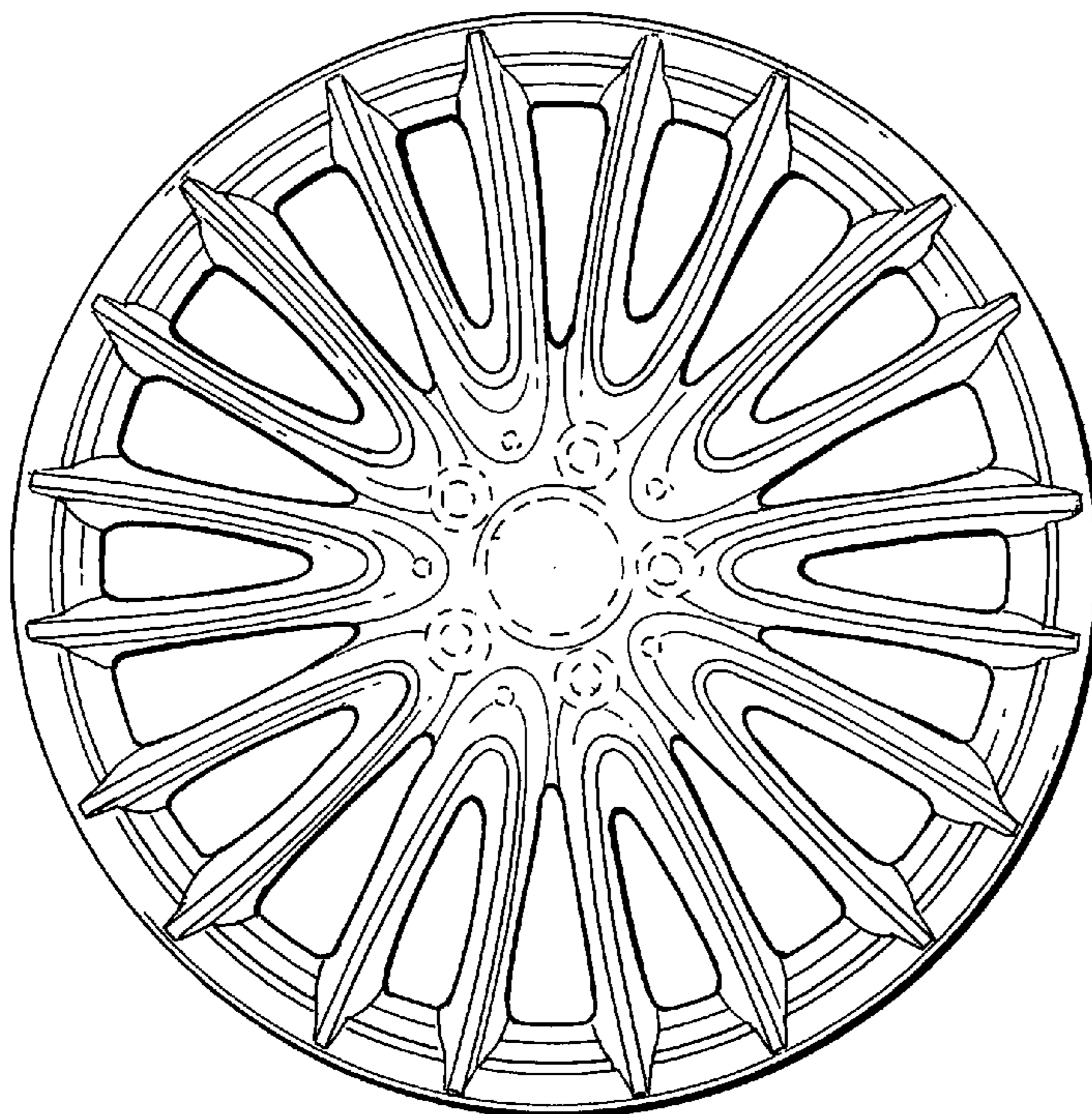

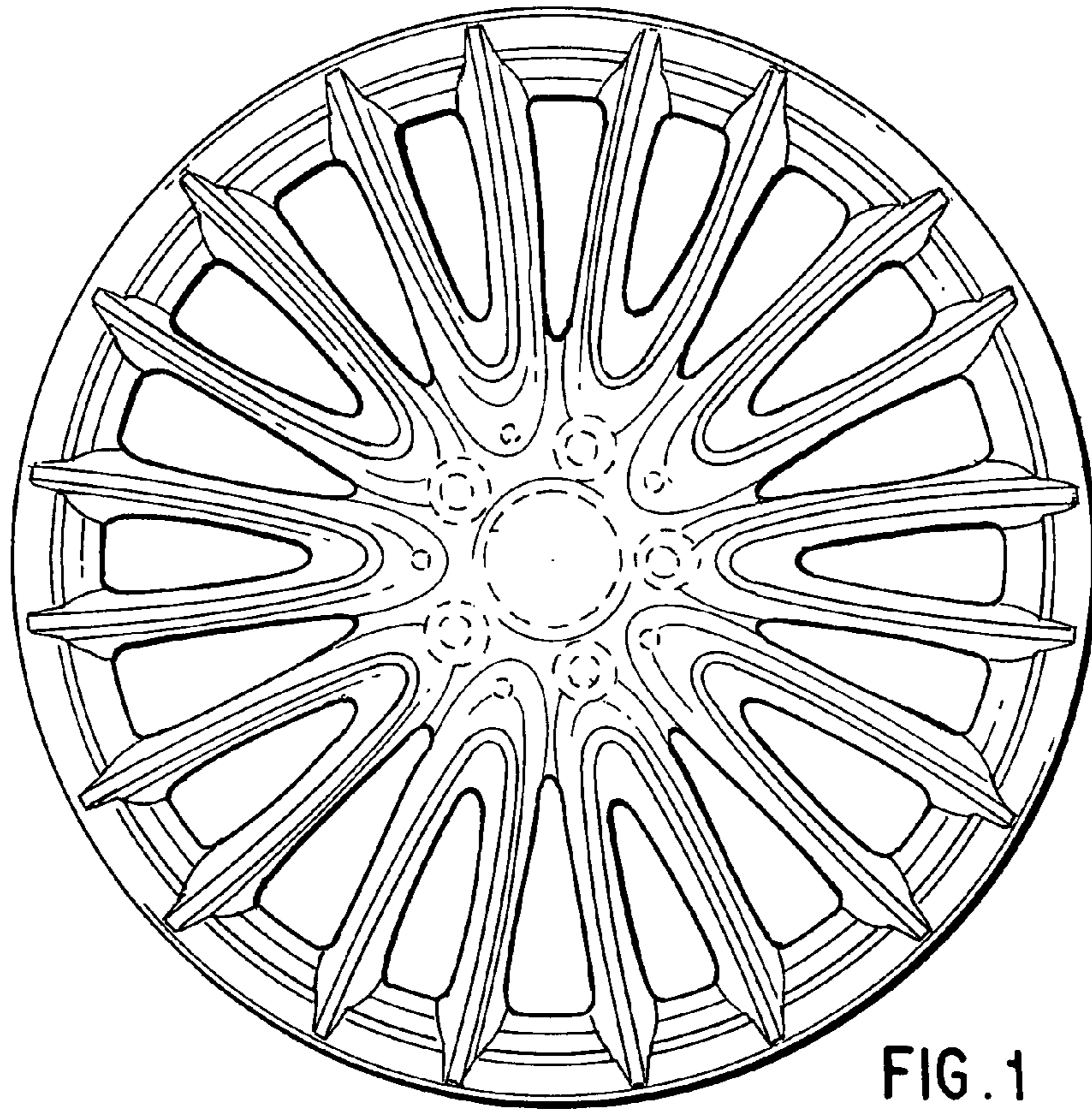

FIG. 1

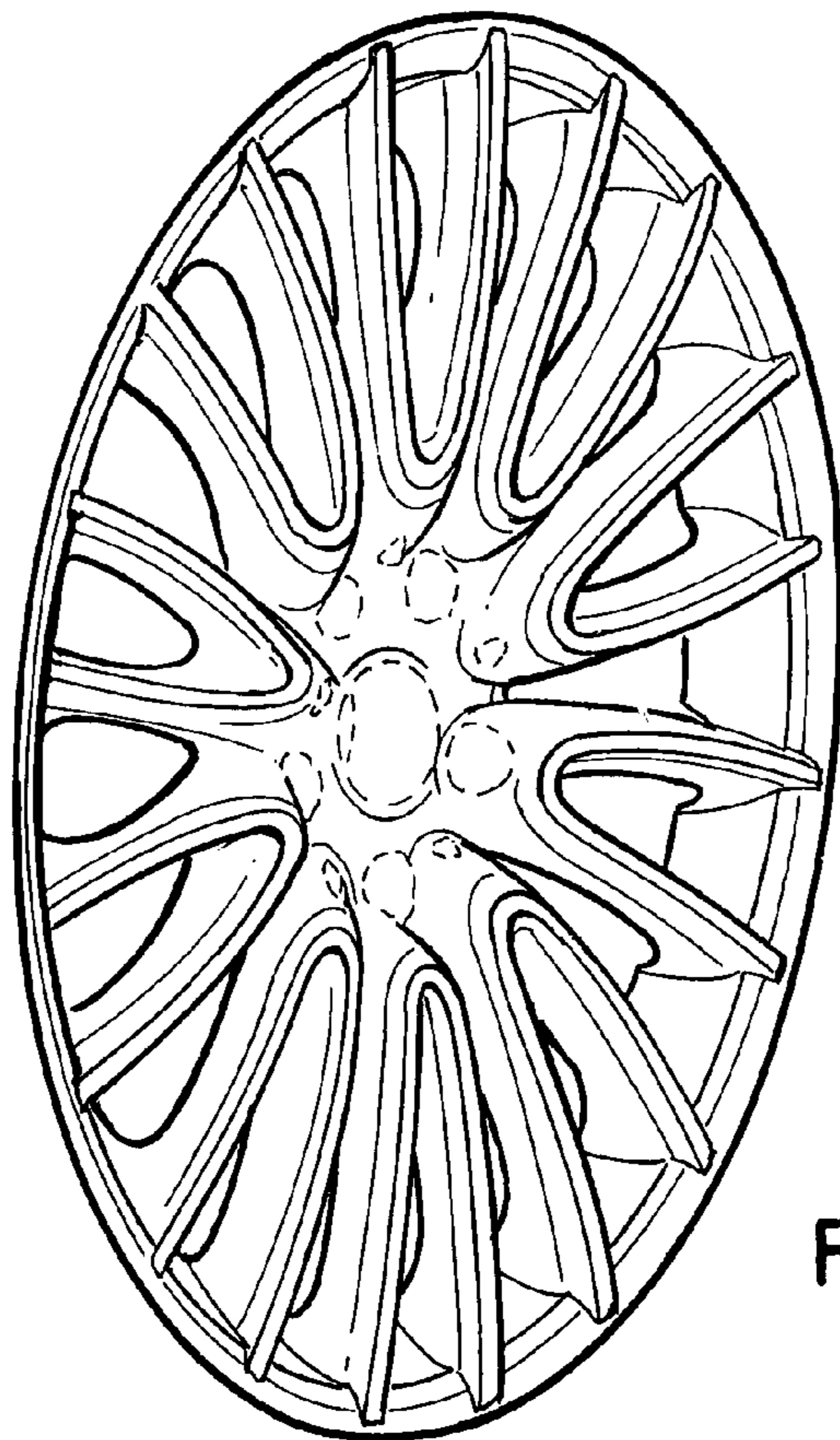

FIG. 2

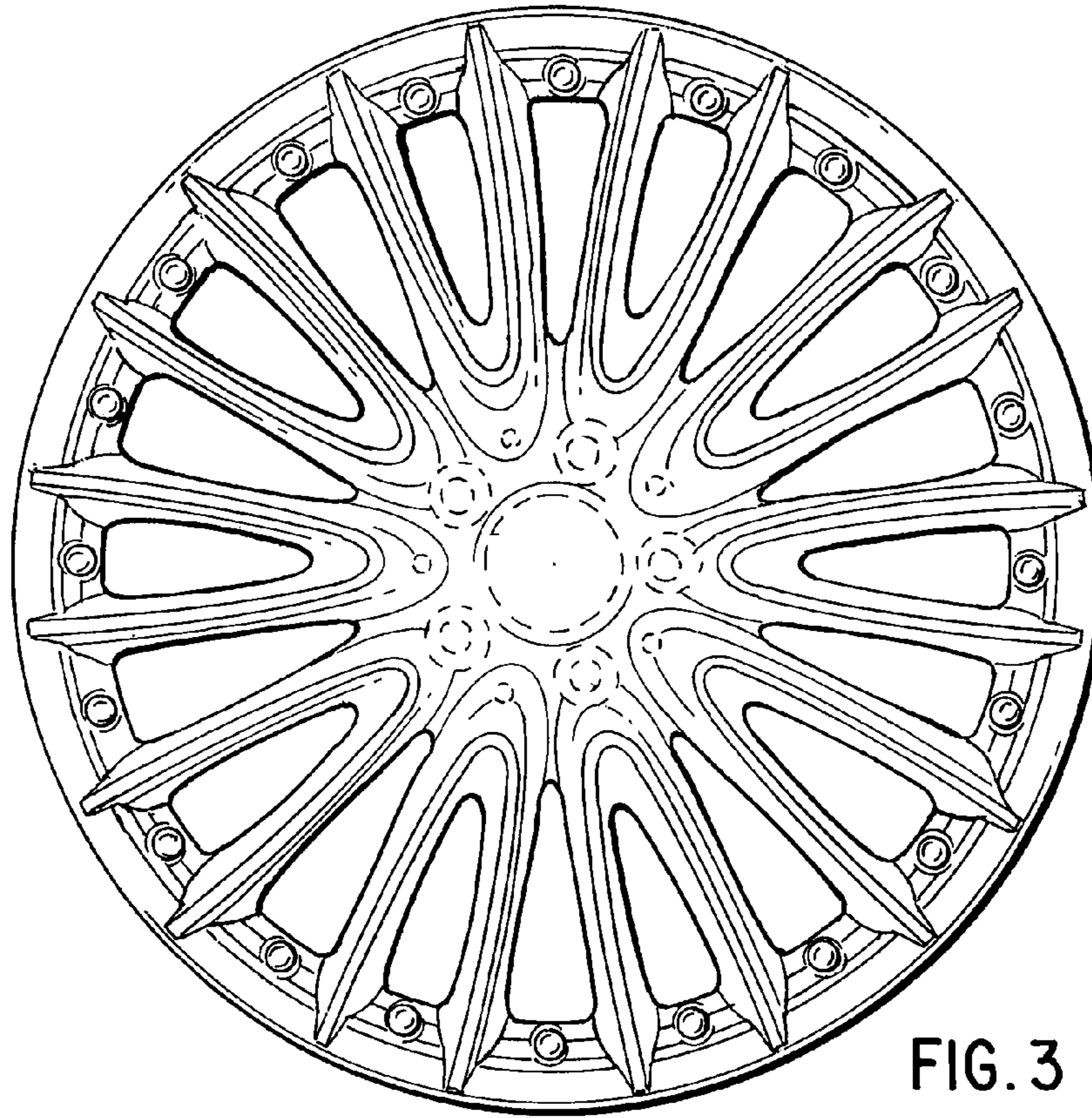

FIG. 3

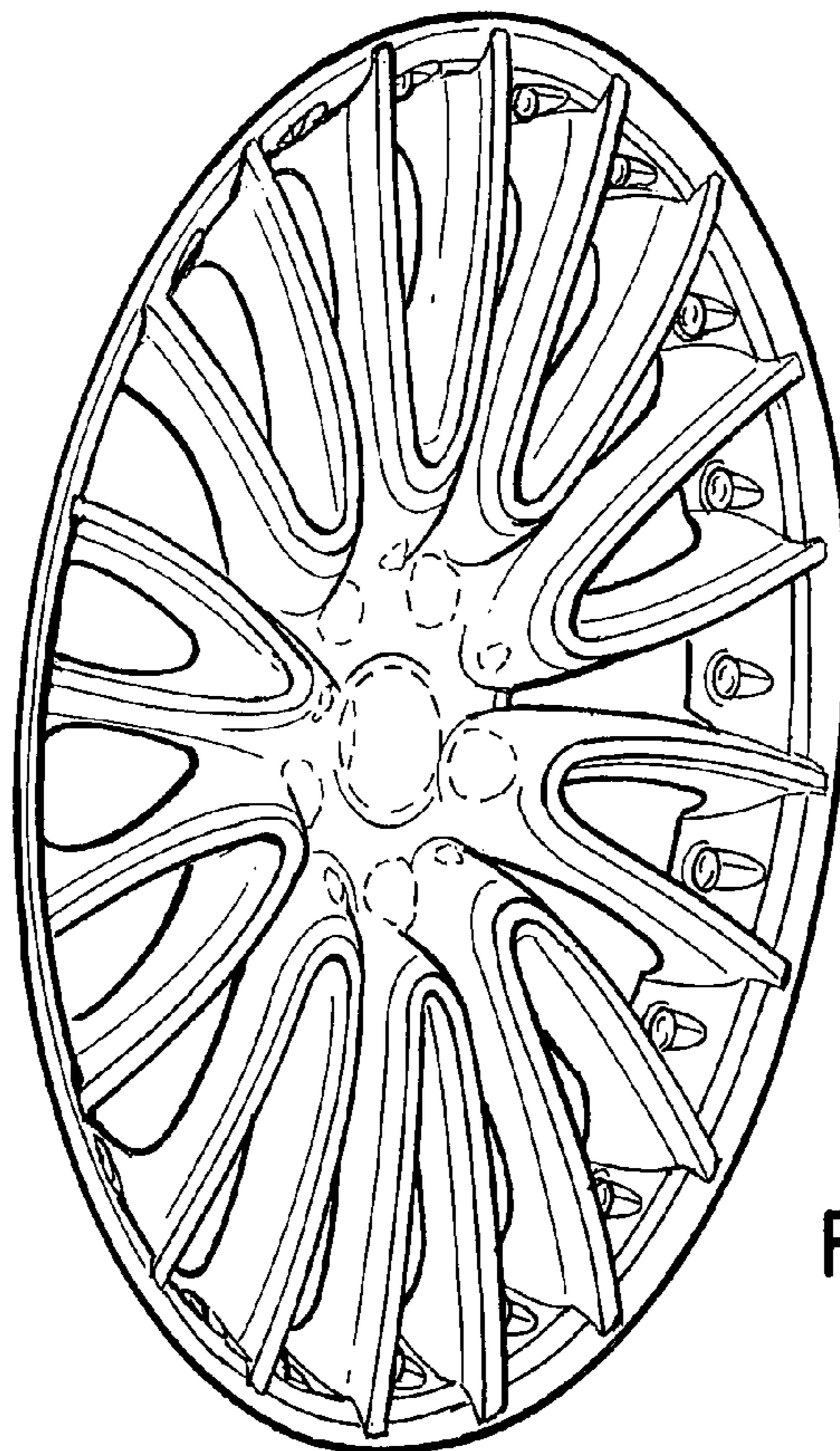

FIG. 4