



US00D590302S

(12) **United States Design Patent**
Tanaka et al.

(10) **Patent No.:** **US D590,302 S**
(45) **Date of Patent:** **** Apr. 14, 2009**

(54) **MOTORCYCLE**

(75) Inventors: **Shunji Tanaka**, Kobe (JP); **Tsutomu Shimizugami**, Kakogawa (JP); **Shuichi Miyanishi**, Kakogawa (JP)

(73) Assignee: **Kawasaki Jukogyo Kabushiki Kaisha**, Hyogo (JP)

(**) Term: **14 Years**

(21) Appl. No.: **29/304,945**

(22) Filed: **Mar. 11, 2008**

(30) **Foreign Application Priority Data**

Sep. 12, 2007 (JP) 2007-024789

(51) **LOC (9) Cl.** **12-11**

(52) **U.S. Cl.** **D12/110**

(58) **Field of Classification Search** D12/110;
180/219, 220, 225, 229

See application file for complete search history.

(56) **References Cited**

U.S. PATENT DOCUMENTS

D269,170 S * 5/1983 Aoyama et al. D12/110
4,691,800 A * 9/1987 Kadono et al. 180/219

D312,807 S * 12/1990 Kohama et al. D12/110
D325,361 S * 4/1992 Gevert D12/110
D385,226 S * 10/1997 Mogi et al. D12/110
D419,922 S * 2/2000 Yamase et al. D12/110

* cited by examiner

Primary Examiner—Robin V Webster
Assistant Examiner—Linda Brooks

(57) **CLAIM**

The ornamental design for a motorcycle, as shown and described.

DESCRIPTION

FIG. 1 is a front elevational view of a motorcycle showing our new design;

FIG. 2 is a rear elevational view thereof;

FIG. 3 is a left side elevational view thereof;

FIG. 4 is a right side elevational view thereof;

FIG. 5 is a top plan view thereof;

FIG. 6 is a bottom plan view thereof;

FIG. 7 is a front perspective view thereof; and,

FIG. 8 is a rear perspective view thereof.

1 Claim, 8 Drawing Sheets

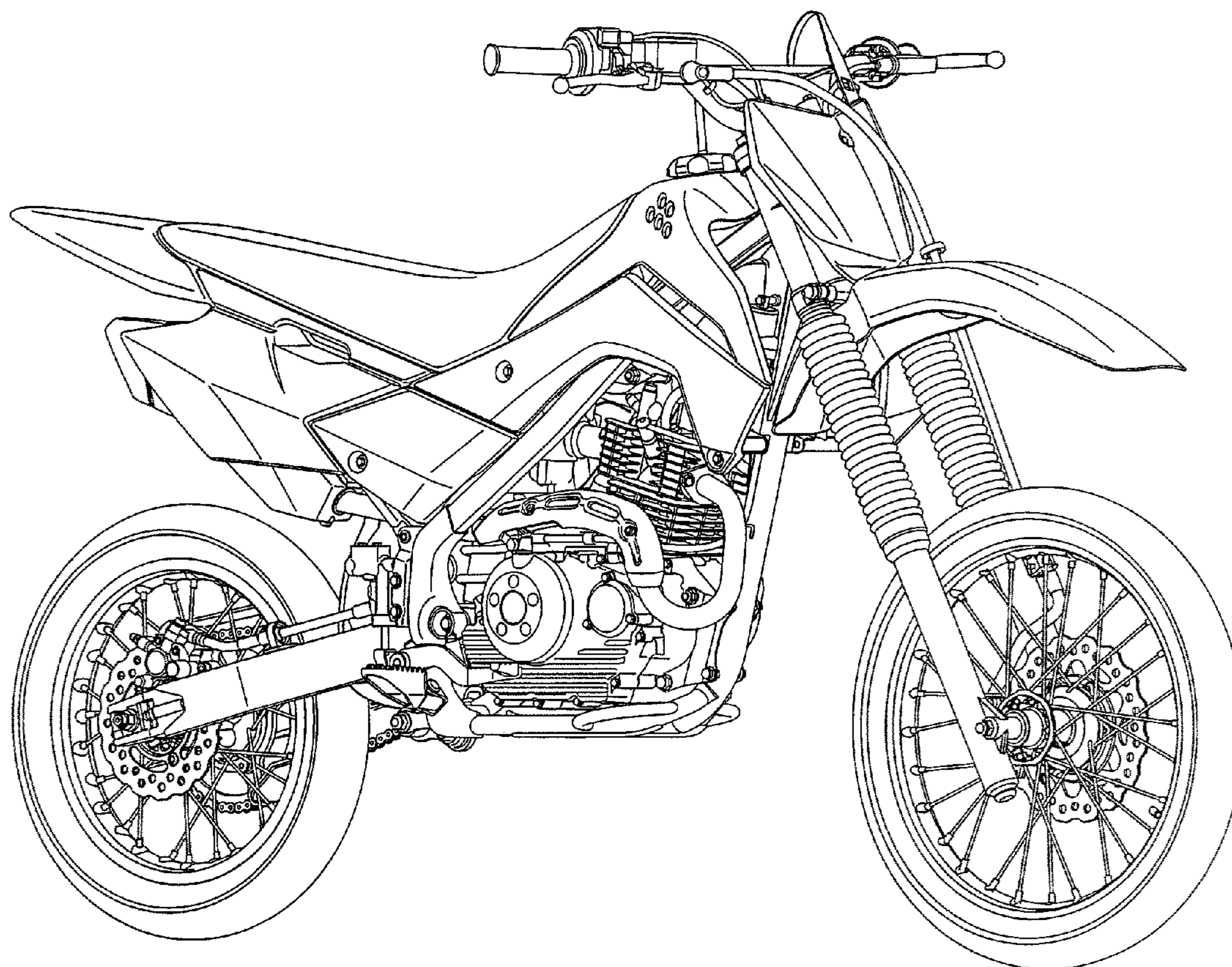

Fig.1

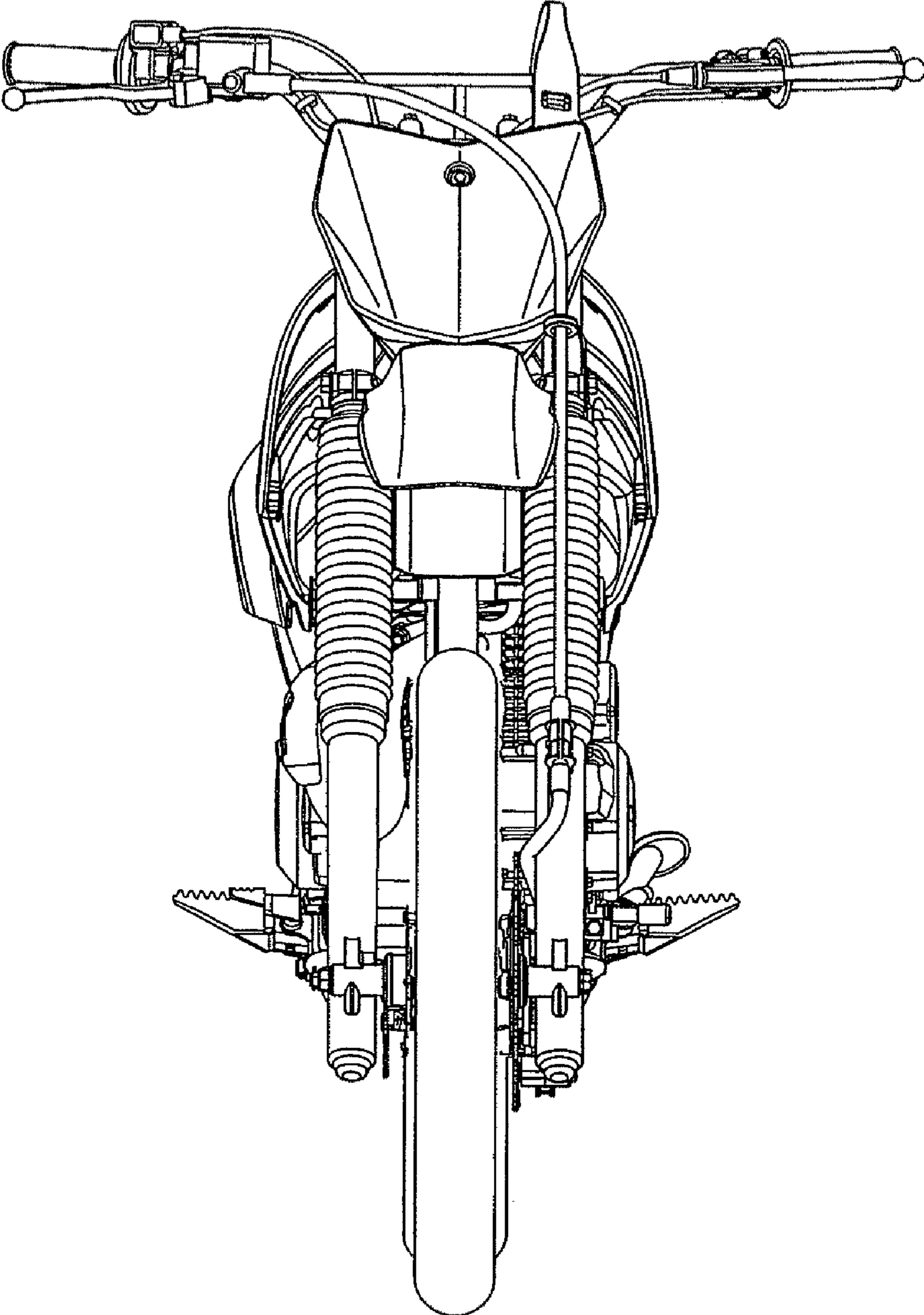
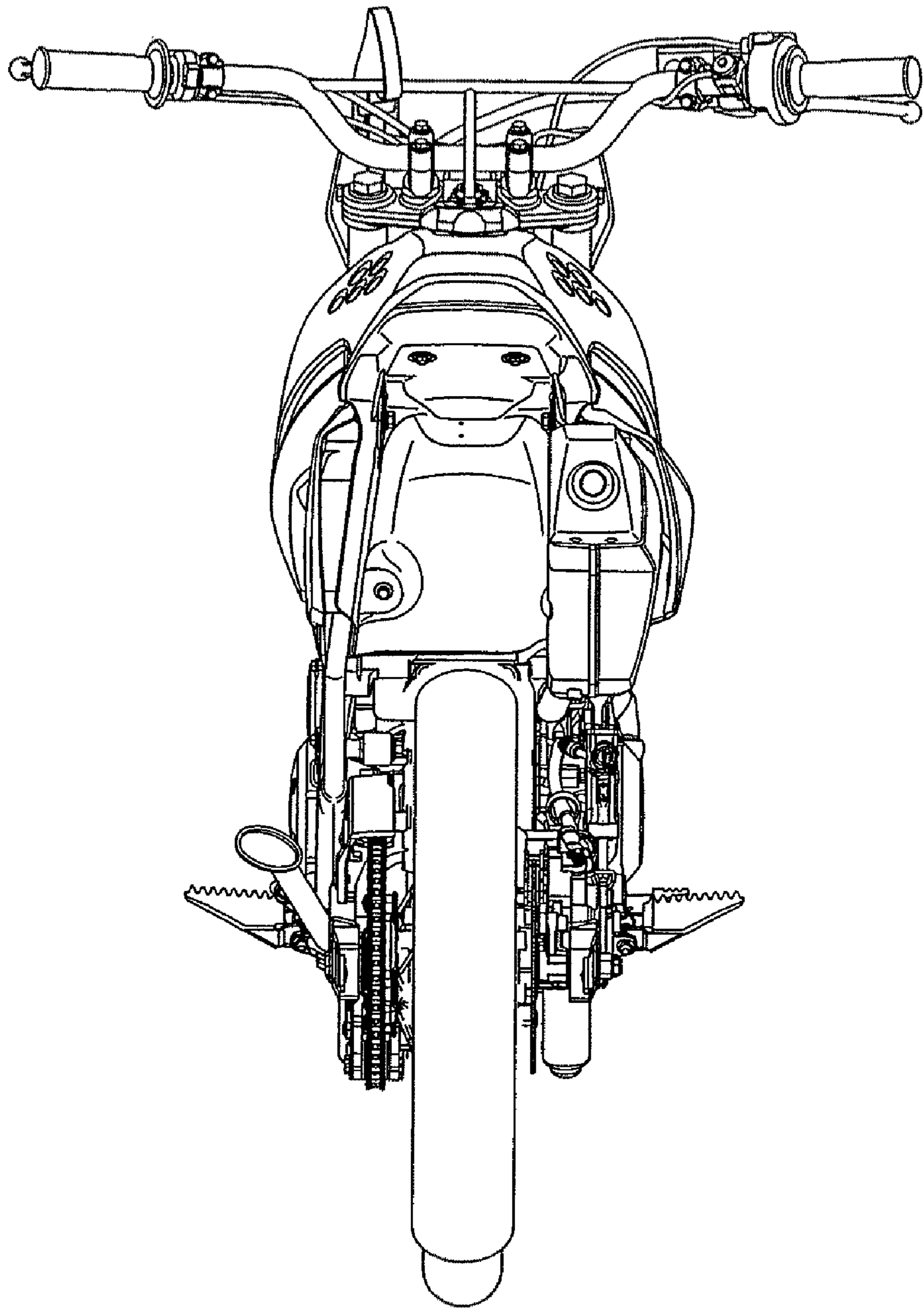

Fig.2



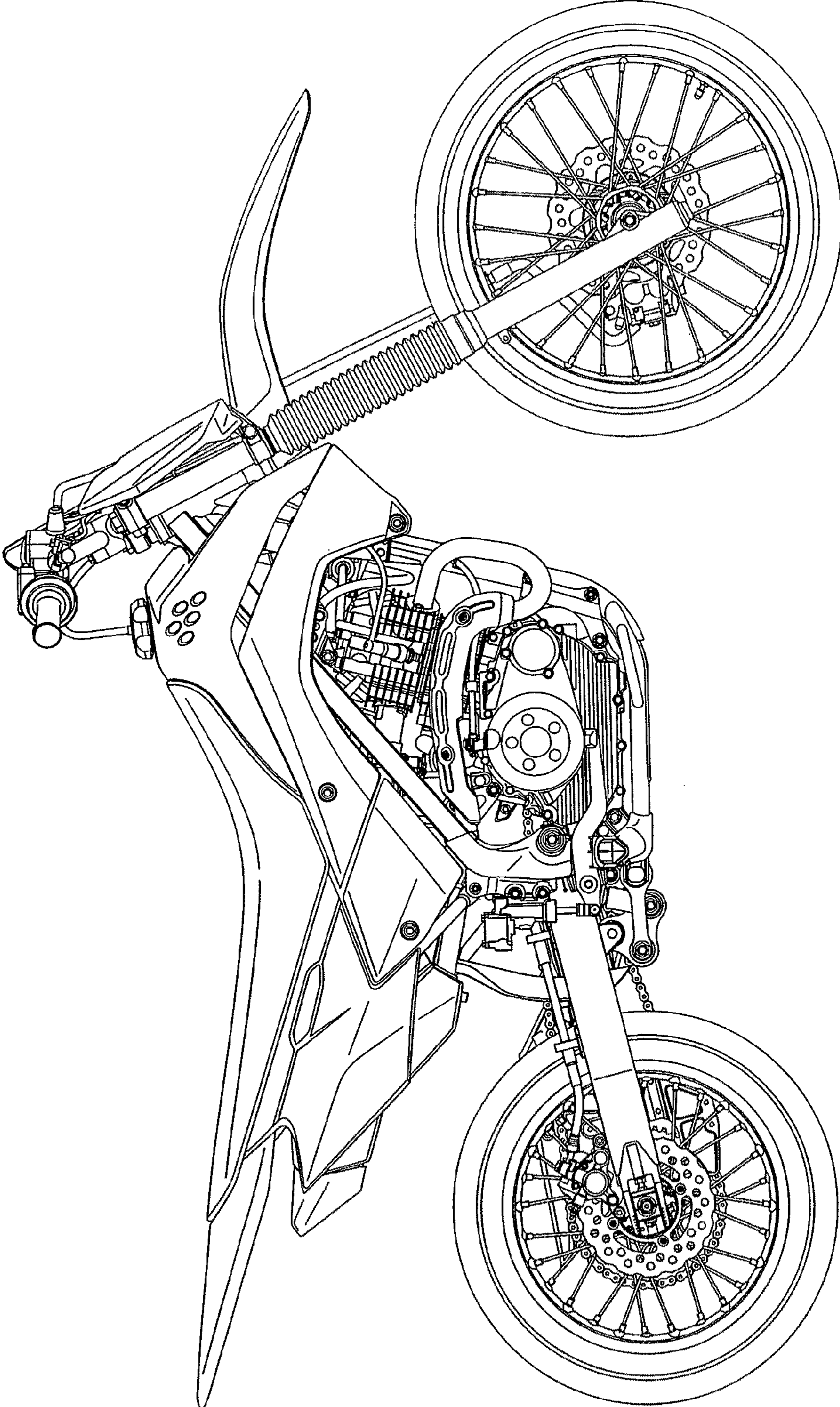

Fig.3

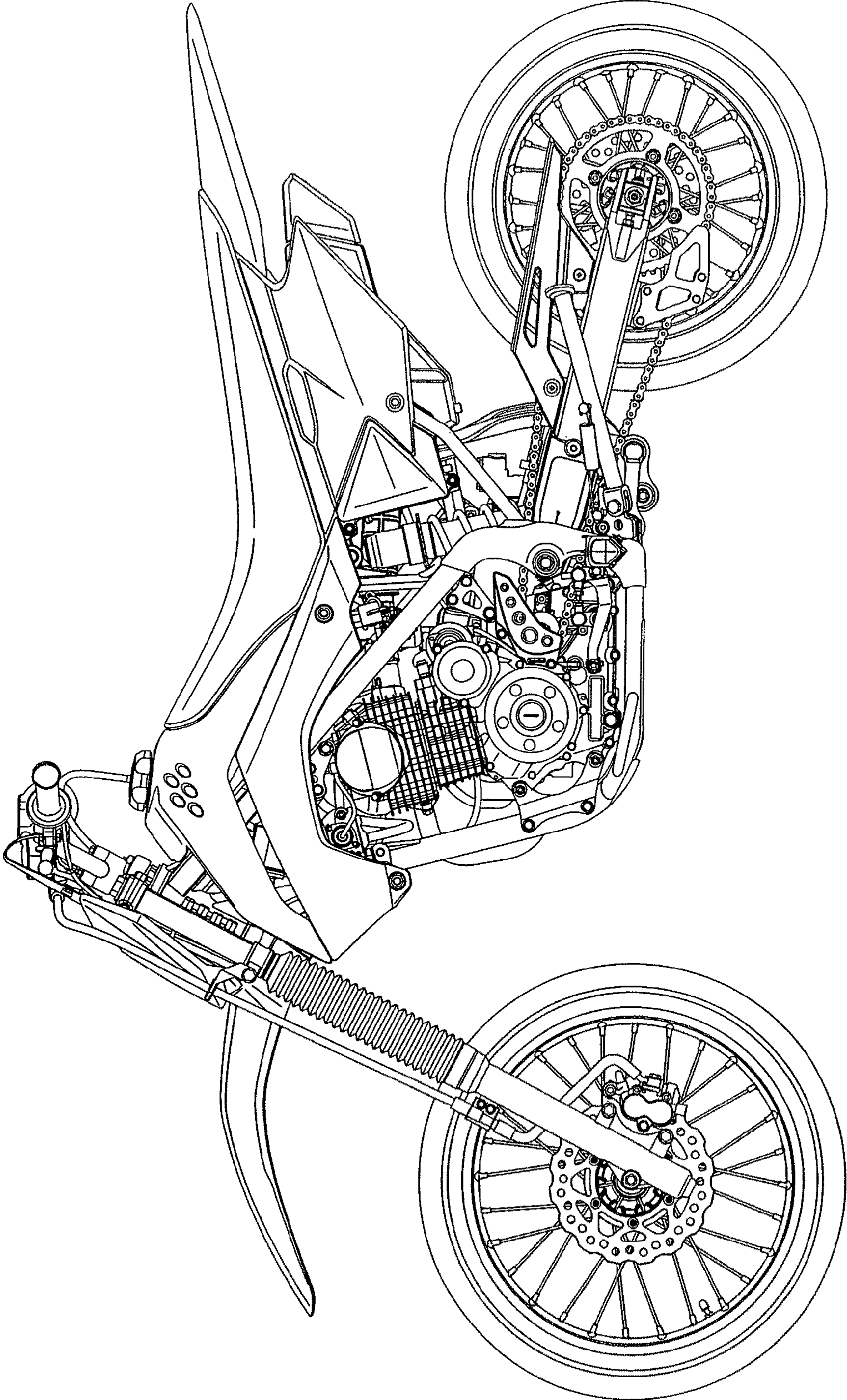

Fig. 4

Fig.5

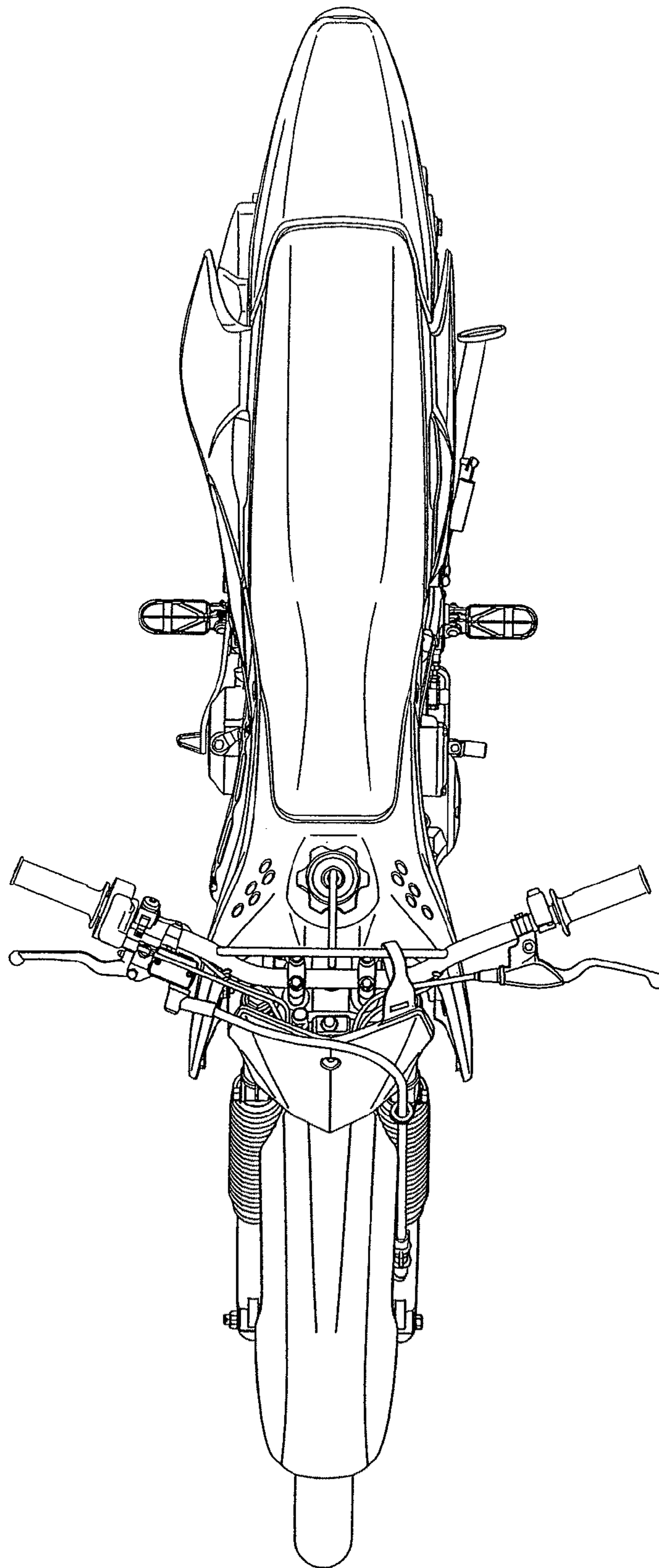
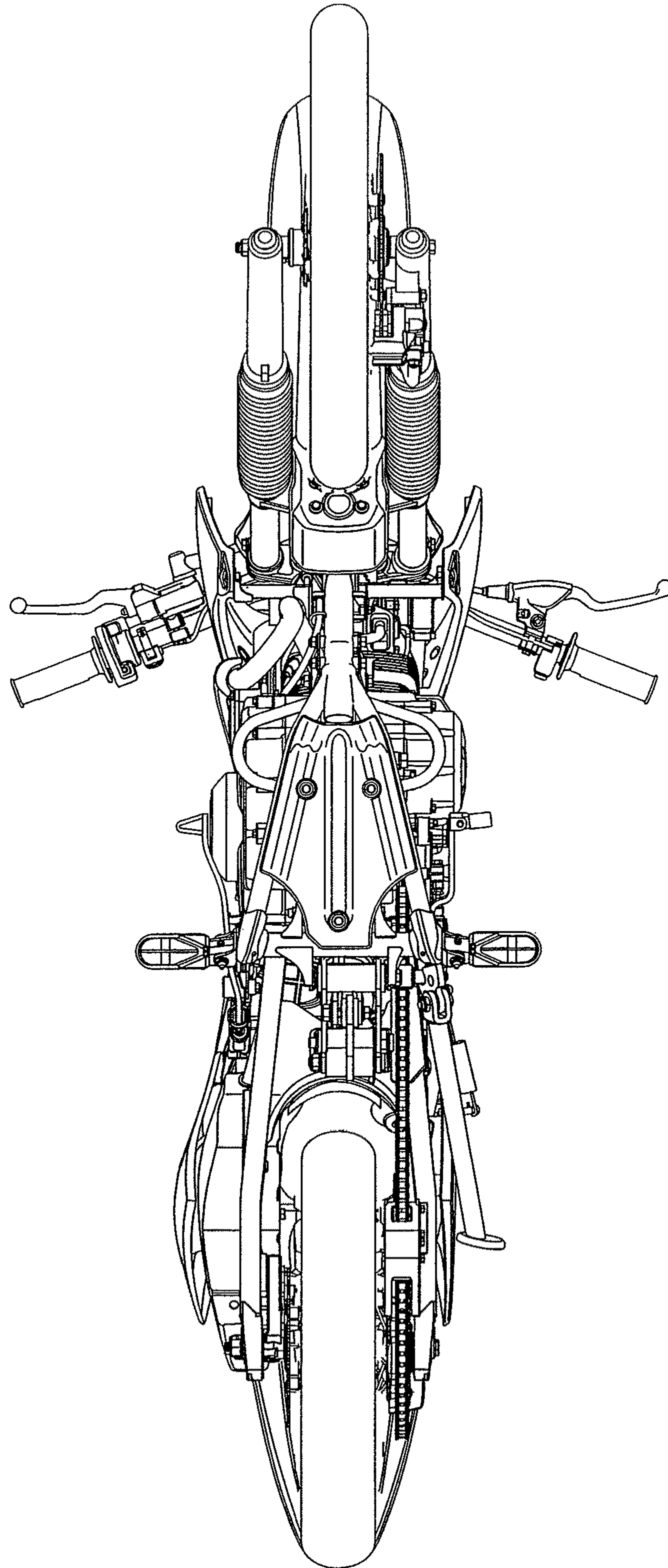

Fig.6



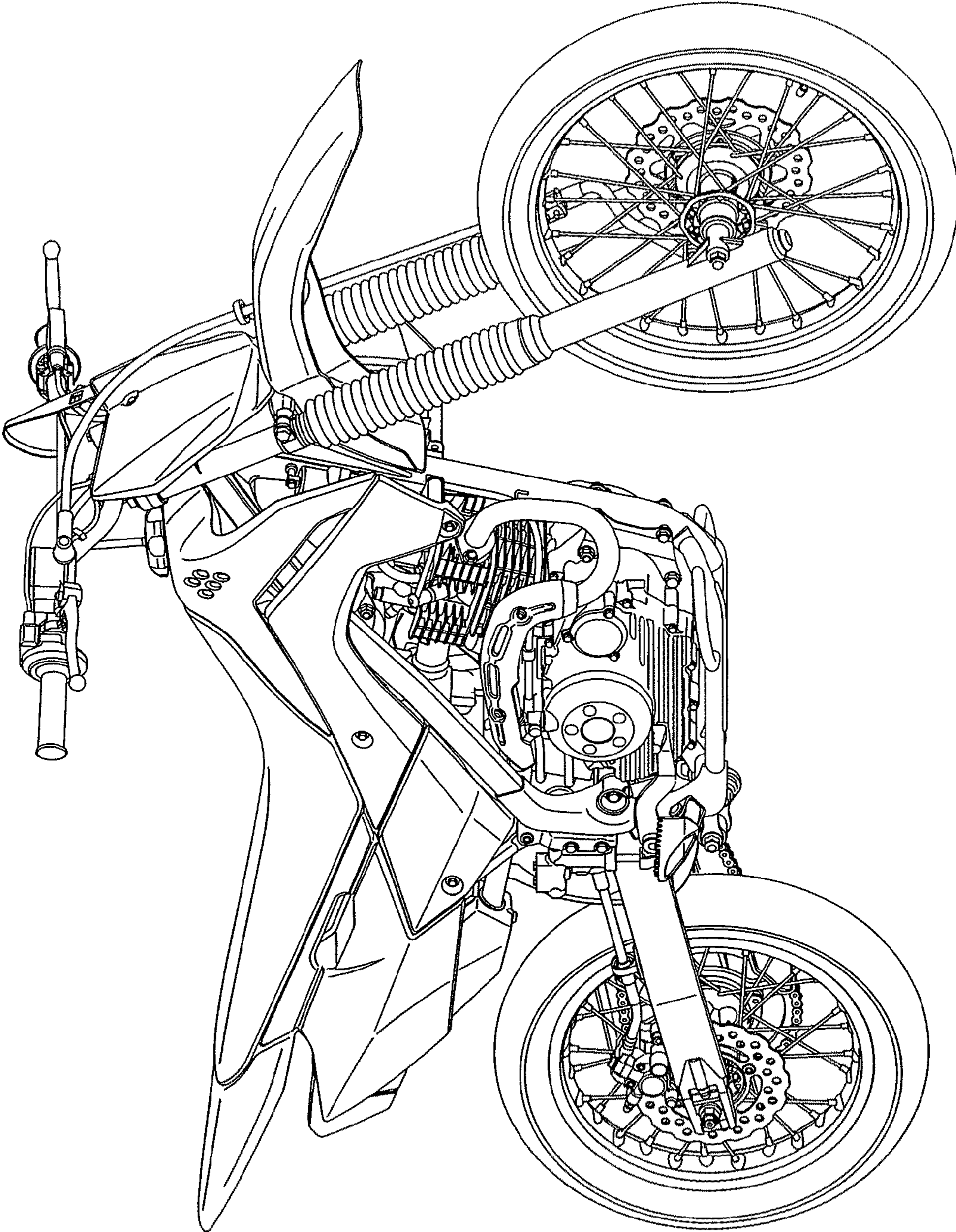

Fig. 7

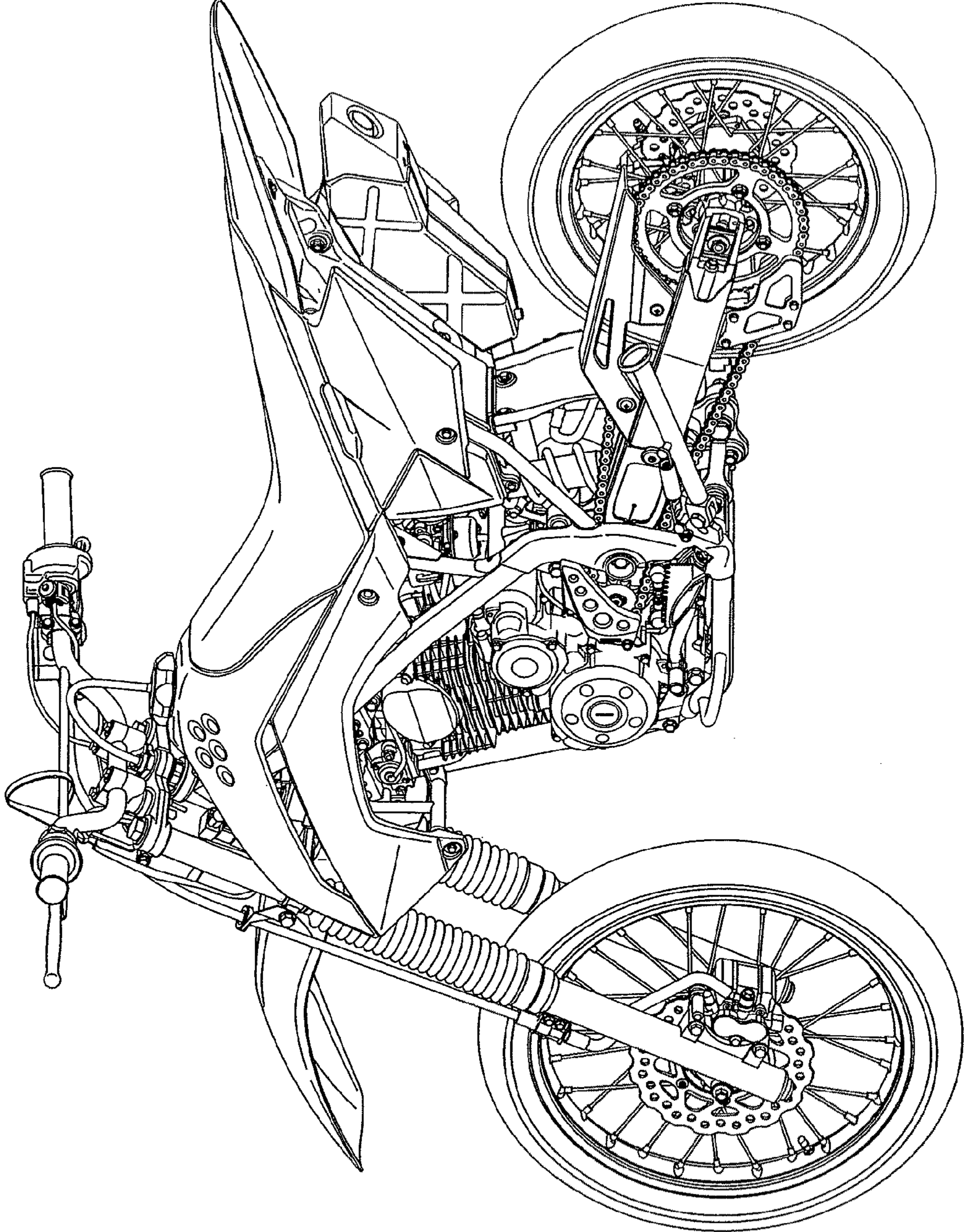

Fig.8