



US00D590161S

(12) **United States Design Patent**
Scoley et al.

(10) **Patent No.:** **US D590,161 S**
(45) **Date of Patent:** **** Apr. 14, 2009**

(54) **SEAT FOR AN AIRCRAFT**

(75) Inventors: **Ian Scoley**, Hamburg (DE); **Ben Atkinson**, London (GB); **Lee Harding**, Kent (GB)

(73) Assignee: **Airbus Deutschland GmbH** (DE)

(**) Term: **14 Years**

(21) Appl. No.: **29/286,683**

(22) Filed: **May 16, 2007**

(30) **Foreign Application Priority Data**

Nov. 16, 2006 (EM) 000622212-0001
Nov. 16, 2006 (EM) 000622212-0002
Nov. 16, 2006 (EM) 000622212-0003

(51) **LOC (9) Cl.** **06-01**

(52) **U.S. Cl.** **D6/356**

(58) **Field of Classification Search** D6/334-336,
D6/356, 367, 368, 371-373, 374, 375, 379,
D6/380, 381, 500-502; 244/122 R; 297/216.1,
297/216.2, 232, 248, 344.1, 353, 354.1, 411.45,
297/452.1, 452.13, 452.19, 452.4
See application file for complete search history.

(56) **References Cited**

U.S. PATENT DOCUMENTS

D268,973 S * 5/1983 White D6/356
D273,642 S * 5/1984 Marrujo D6/356
5,984,415 A * 11/1999 Schumacher et al. 244/122 R
6,135,554 A * 10/2000 Tsun et al. 297/327
6,481,798 B2 * 11/2002 Romca et al. 297/354.1

6,644,738 B2 * 11/2003 Williamson 297/232
6,669,143 B1 * 12/2003 Johnson 244/122 R
6,799,805 B2 * 10/2004 Johnson 297/248
6,802,568 B1 * 10/2004 Johnson 297/452.13
6,824,213 B2 * 11/2004 Skelly et al. 297/452.13
D505,796 S * 6/2005 Johnson D6/356
7,066,551 B2 * 6/2006 Johnson 244/122 R

* cited by examiner

Primary Examiner—Mimosa De

(74) *Attorney, Agent, or Firm*—Lerner, David, Littenberg, Krumholz & Mentlik, LLP

(57) **CLAIM**

The ornamental design for seat for an aircraft, as shown and described.

DESCRIPTION

FIG. 1 is a side perspective view of the subject seat for an aircraft;

FIG. 2 is a front plan view;

FIG. 3 is a back plan view;

FIG. 4 is a left side view;

FIG. 5 is a right side view;

FIG. 6 is a top plan view; and,

FIG. 7 is a bottom plan view.

The broken lines in the drawing are for illustrative purposes and form no part of the claimed design or the embodiments in which they appear. The areas within and outside of the broken lines form the design claimed by the applicants.

1 Claim, 7 Drawing Sheets

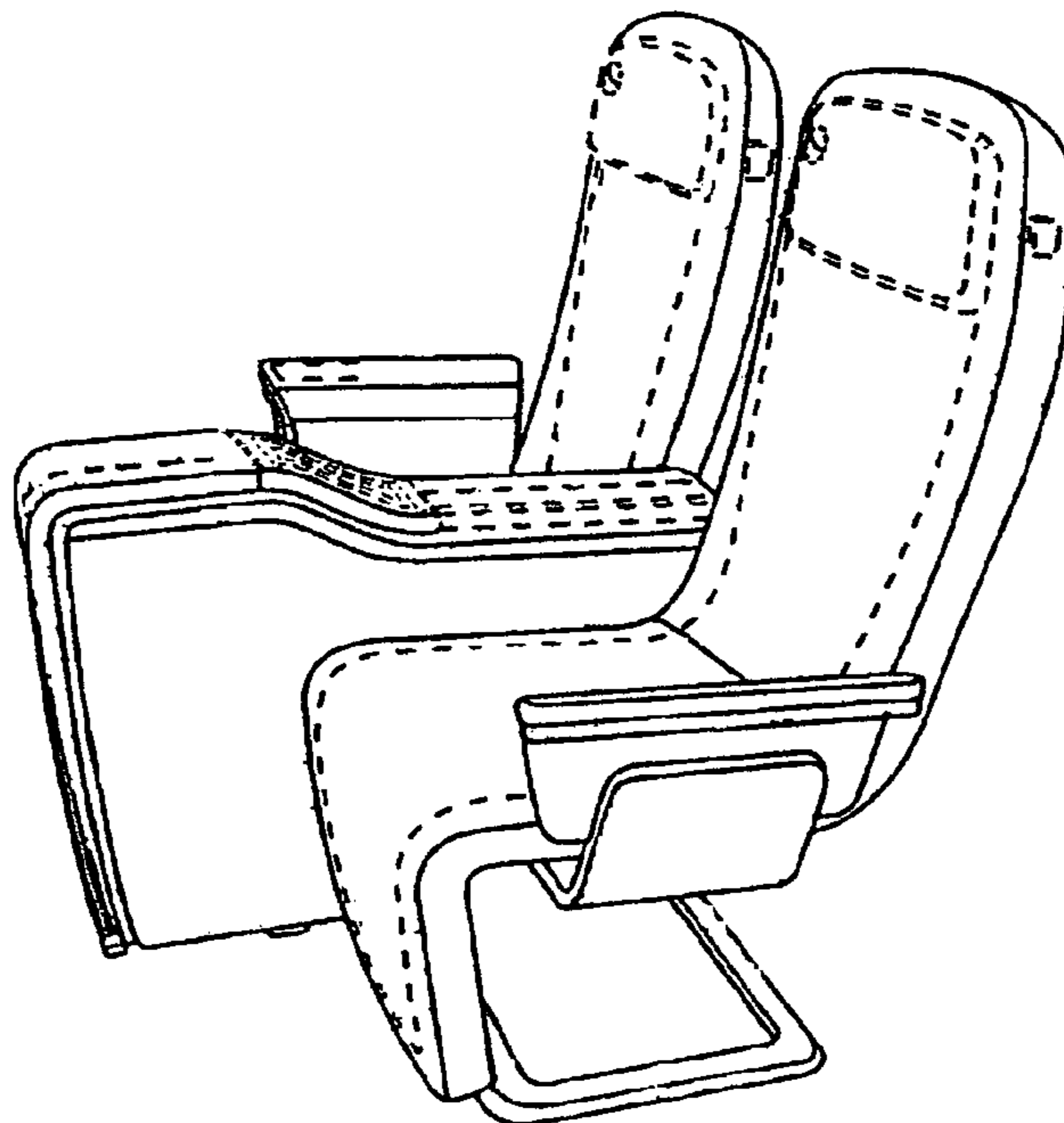

FIG. 1

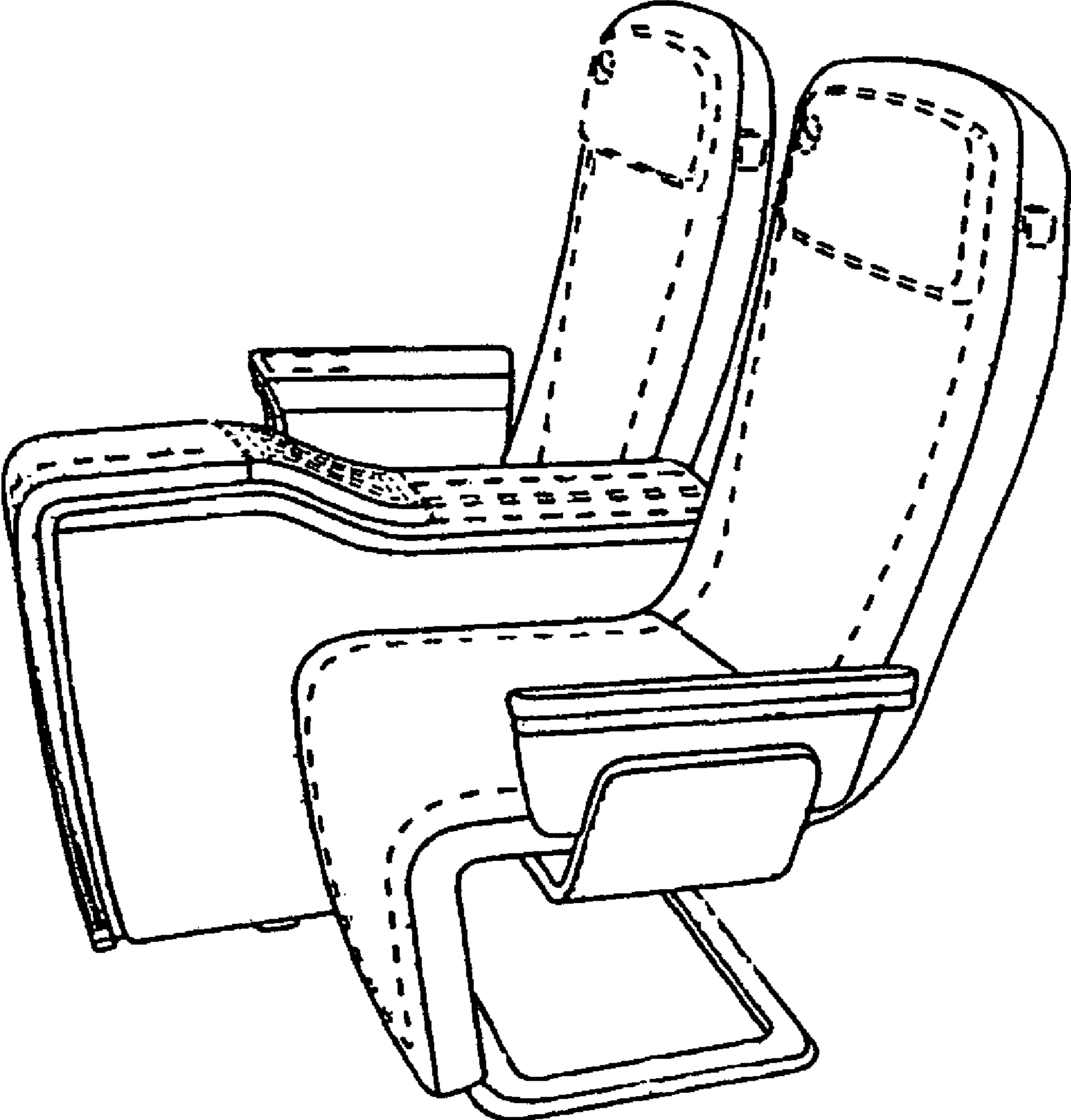

FIG. 2

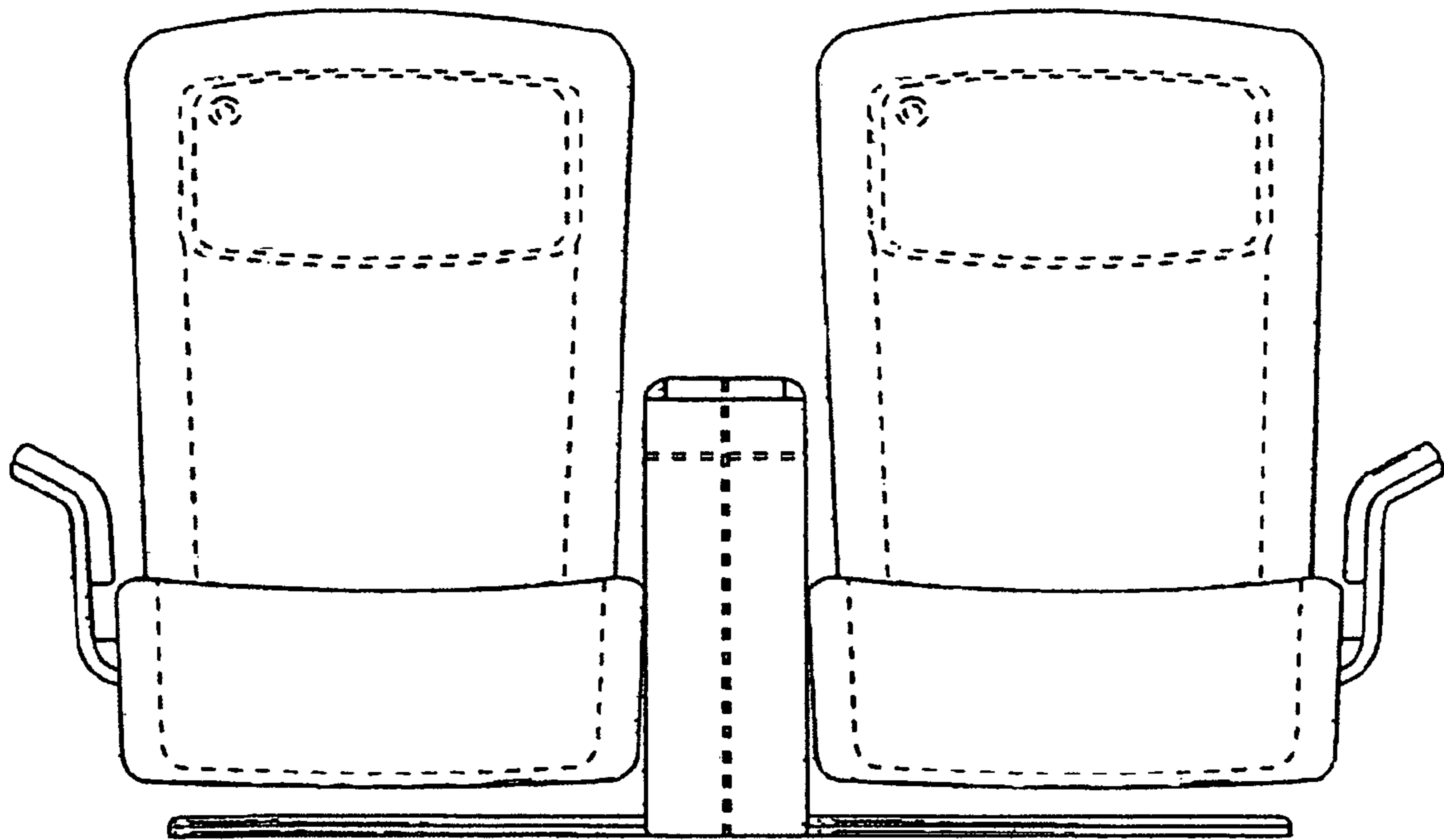

FIG. 3

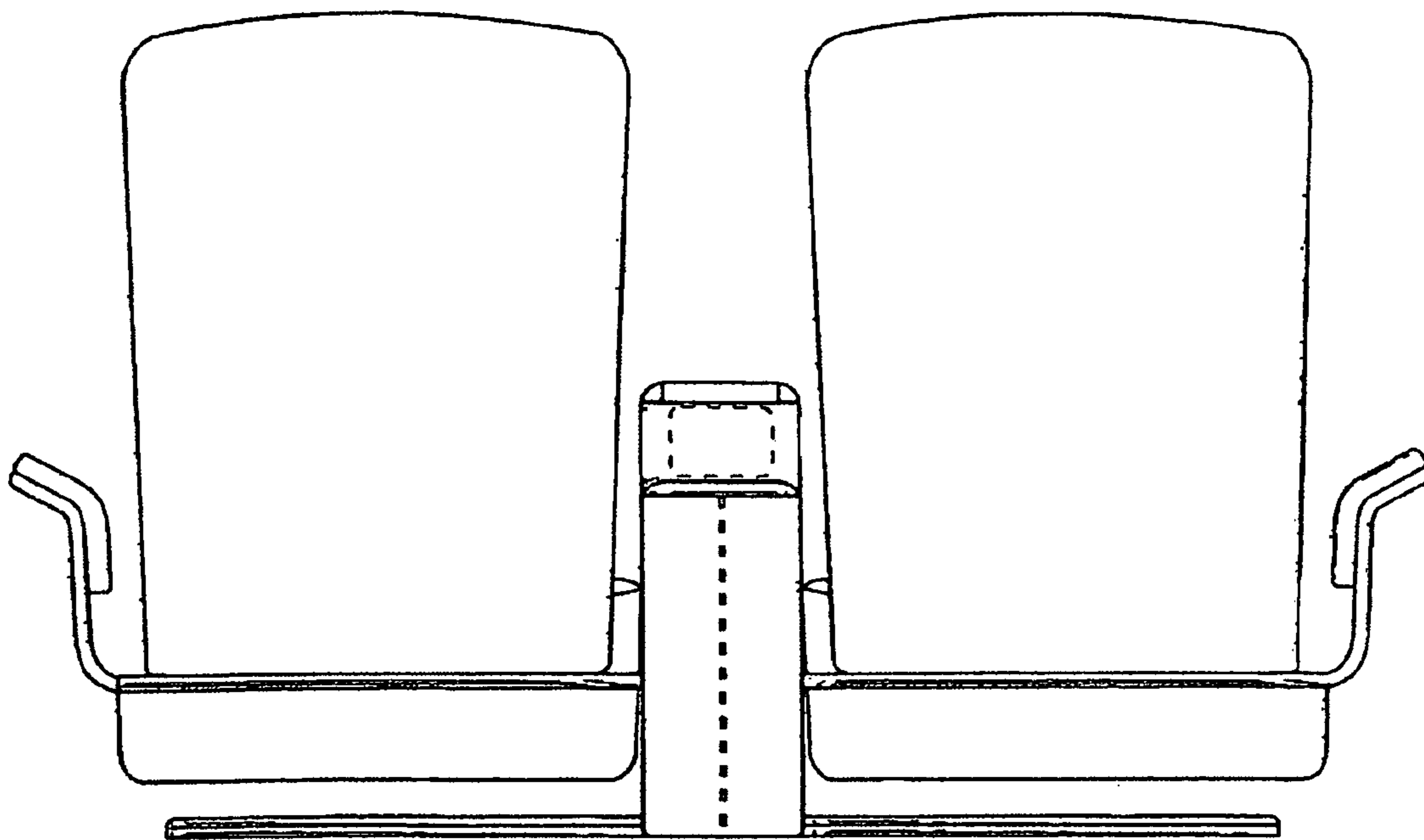

FIG. 4

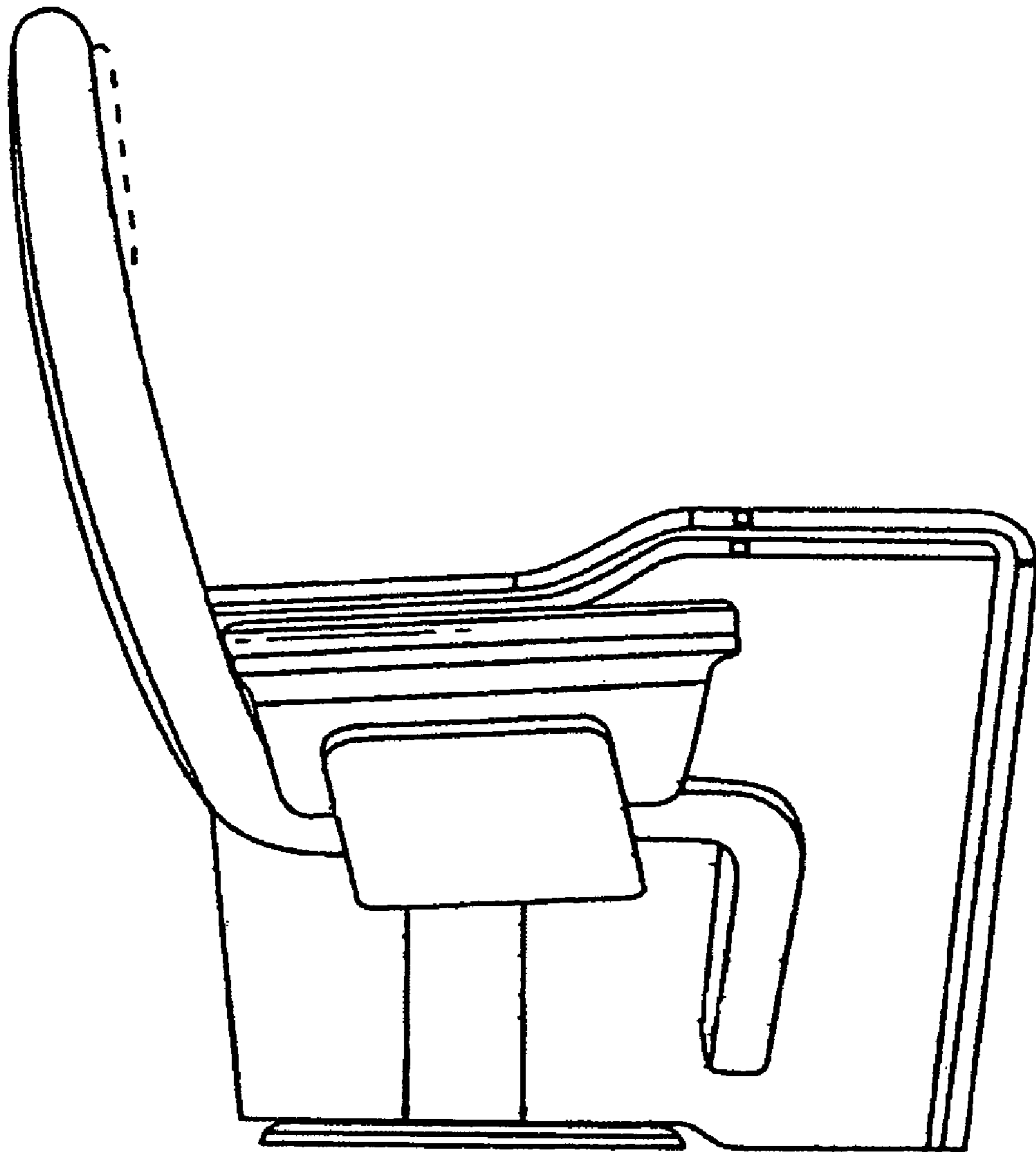

FIG. 5

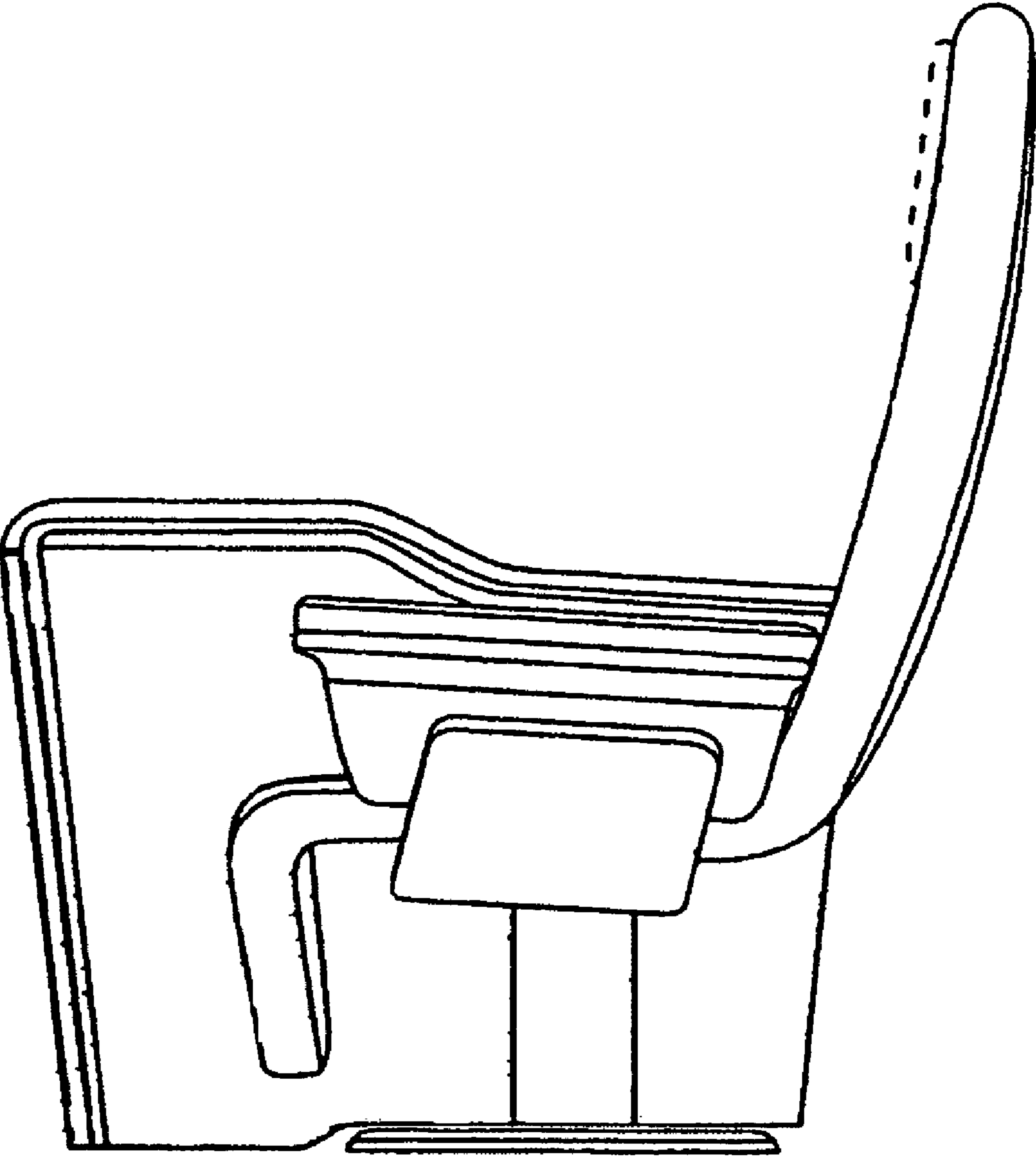

FIG. 6

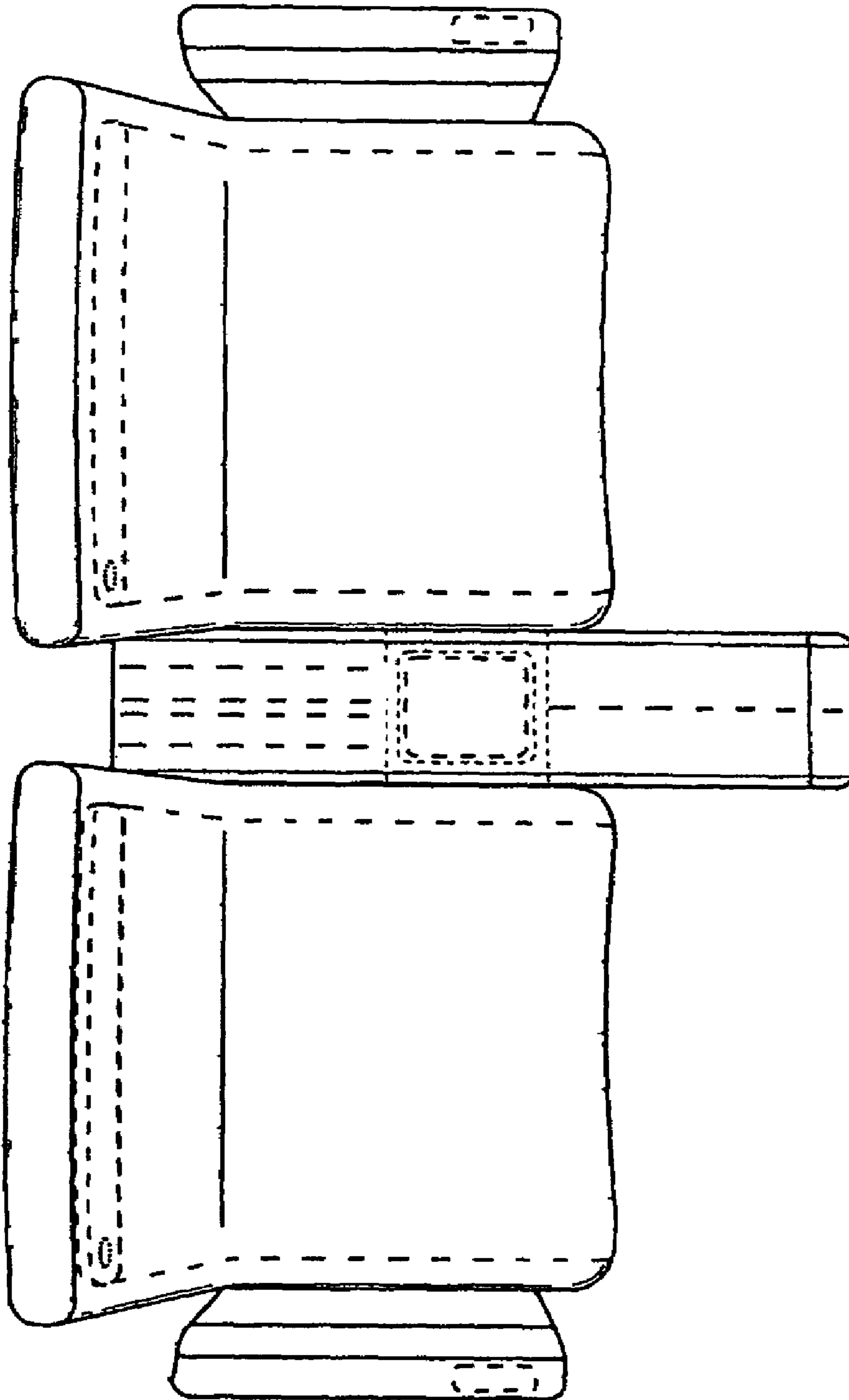

FIG. 7

