



US00D589844S

(12) **United States Design Patent**  
**Aubé et al.**

(10) **Patent No.:** **US D589,844 S**

(45) **Date of Patent:** **\*\* Apr. 7, 2009**

(54) **THREE-WHEELED VEHICLE**

(75) Inventors: **Martin Aubé**, Saint-Bruno (CA);  
**Johnathan Côté**, Montréal (CA);  
**Alexandre Huneau**, Mascouche (CA);  
**Danny Higgins**, Chambly (CA)

(73) Assignee: **L'Unité Créative Inc.**, St-Bruno,  
Québec (CA)

(\*\*) Term: **14 Years**

(21) Appl. No.: **29/305,135**

(22) Filed: **Mar. 14, 2008**

(51) **LOC (9) Cl.** ..... **12-08**

(52) **U.S. Cl.** ..... **D12/85**

(58) **Field of Classification Search** ..... D12/85,  
D12/86; D21/424, 433, 434; 296/181.1,  
296/181.5

See application file for complete search history.

(56) **References Cited**

**U.S. PATENT DOCUMENTS**

D424,979 S \* 5/2000 Hanagan et al. .... D12/85  
D427,548 S \* 7/2000 Sacco et al. .... D12/85  
D469,037 S \* 1/2003 Hanagan et al. .... D12/85

**OTHER PUBLICATIONS**

Internet pictures. Earliest known date of Apr. 12, 2007.

\* cited by examiner

*Primary Examiner*—Melody N Brown

(74) *Attorney, Agent, or Firm*—Benoit & Côté

(57) **CLAIM**

The ornamental design for a three-wheeled vehicle, as shown and described.

**DESCRIPTION**

In a preferred embodiment, the nature of this product is a three-wheeled vehicle.

FIG. 1 is a perspective view from the front and top of a three-wheeled vehicle according to the present design;

FIG. 2 is a perspective view from the rear and top thereof;

FIG. 3 is a front elevational view thereof;

FIG. 4 is a rear elevational view thereof;

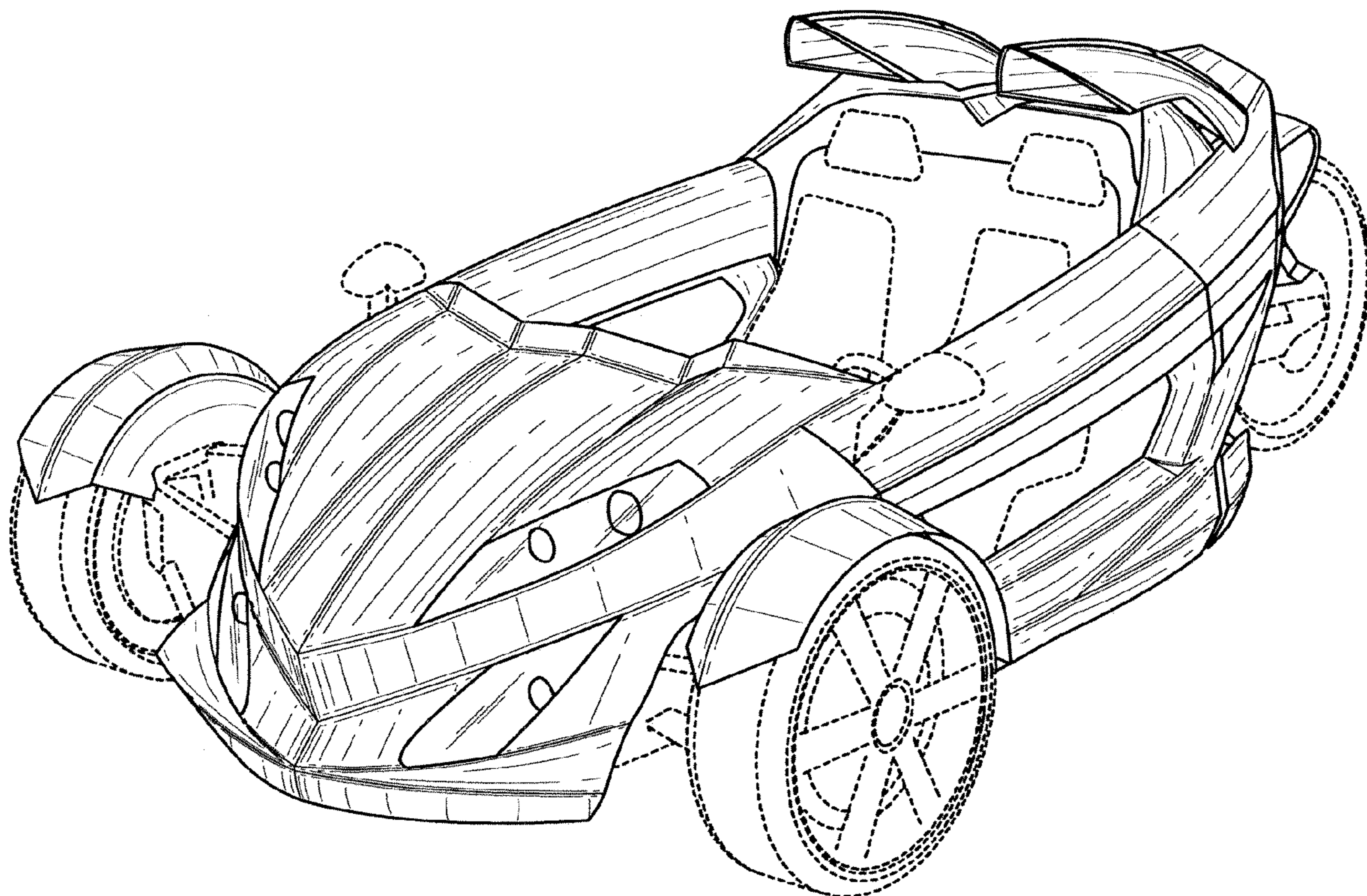
FIG. 5 is a right elevational view thereof;

FIG. 6 is a left elevational view thereof; and,

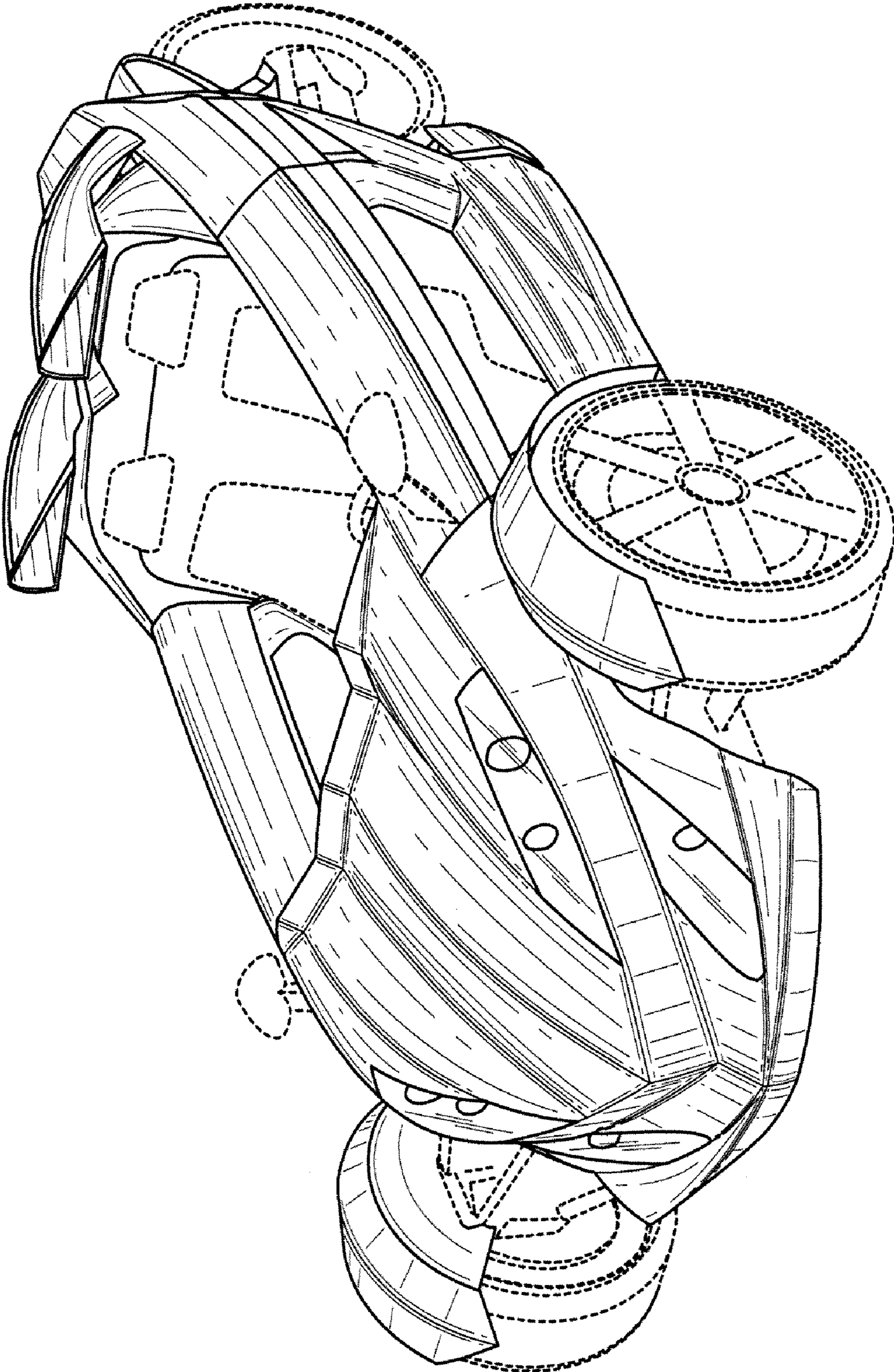
FIG. 7 is a top view thereof;

The broken lines are for illustrative purposes only and form no part of the claimed design.

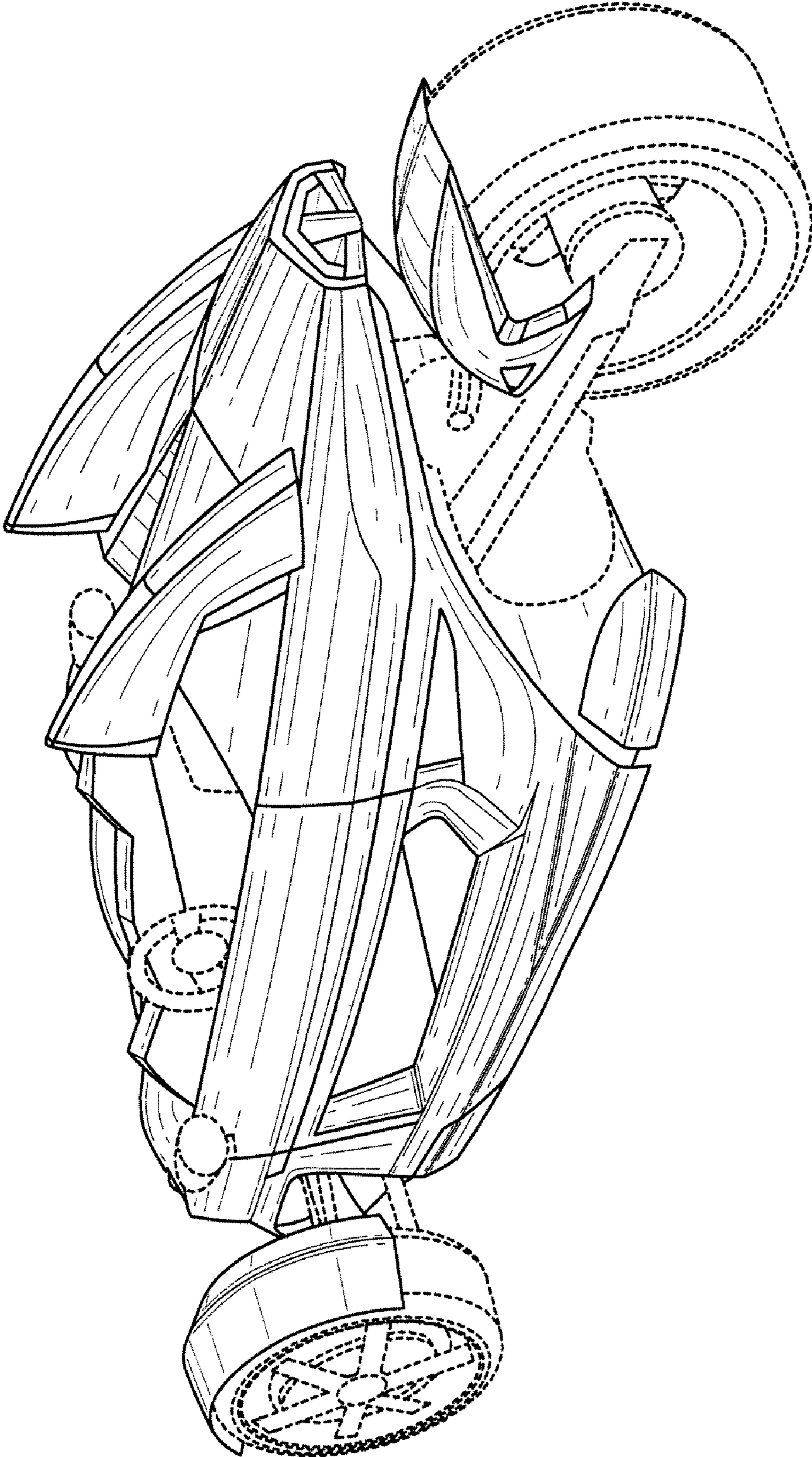
**1 Claim, 6 Drawing Sheets**





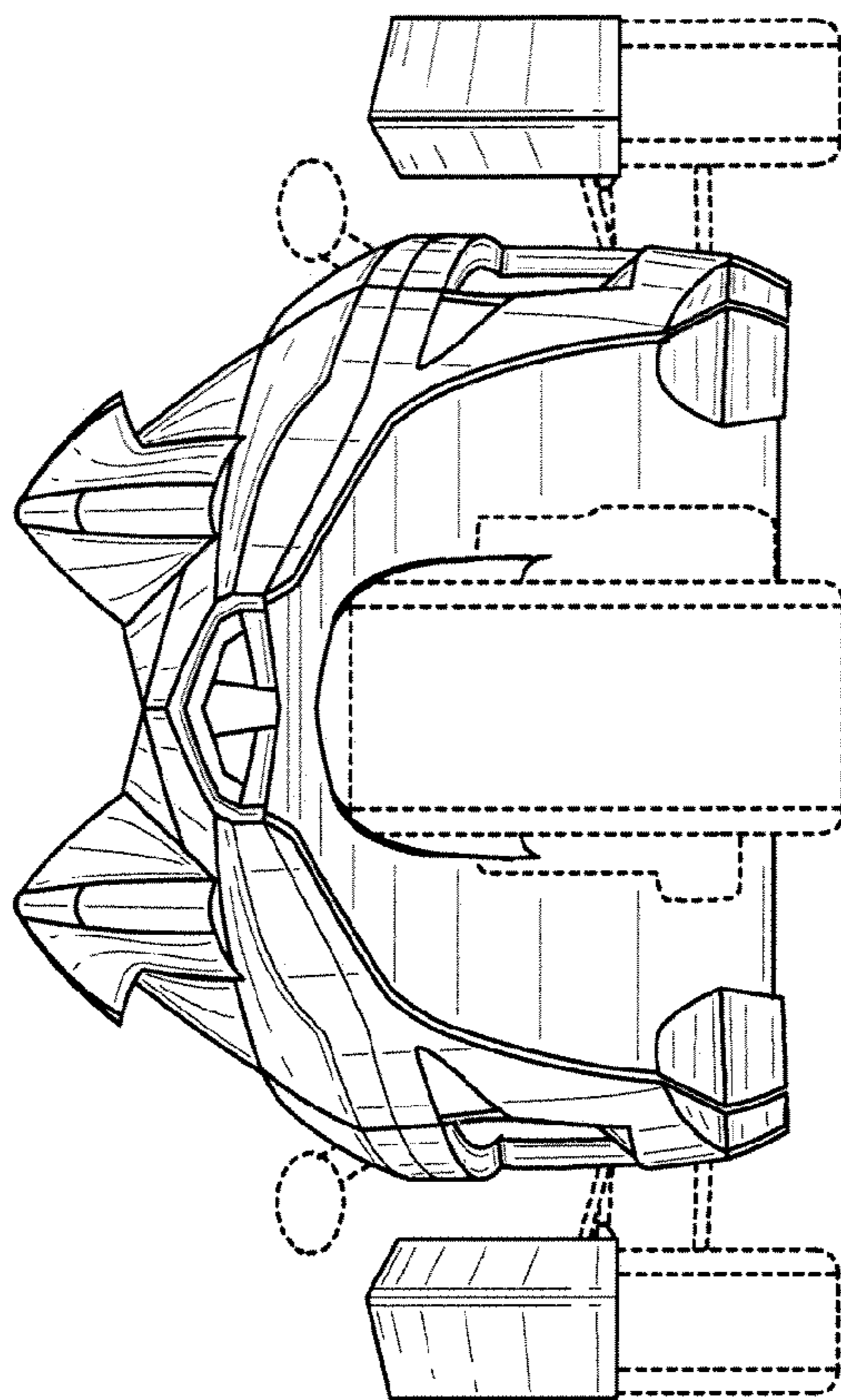


**FIG. 1**

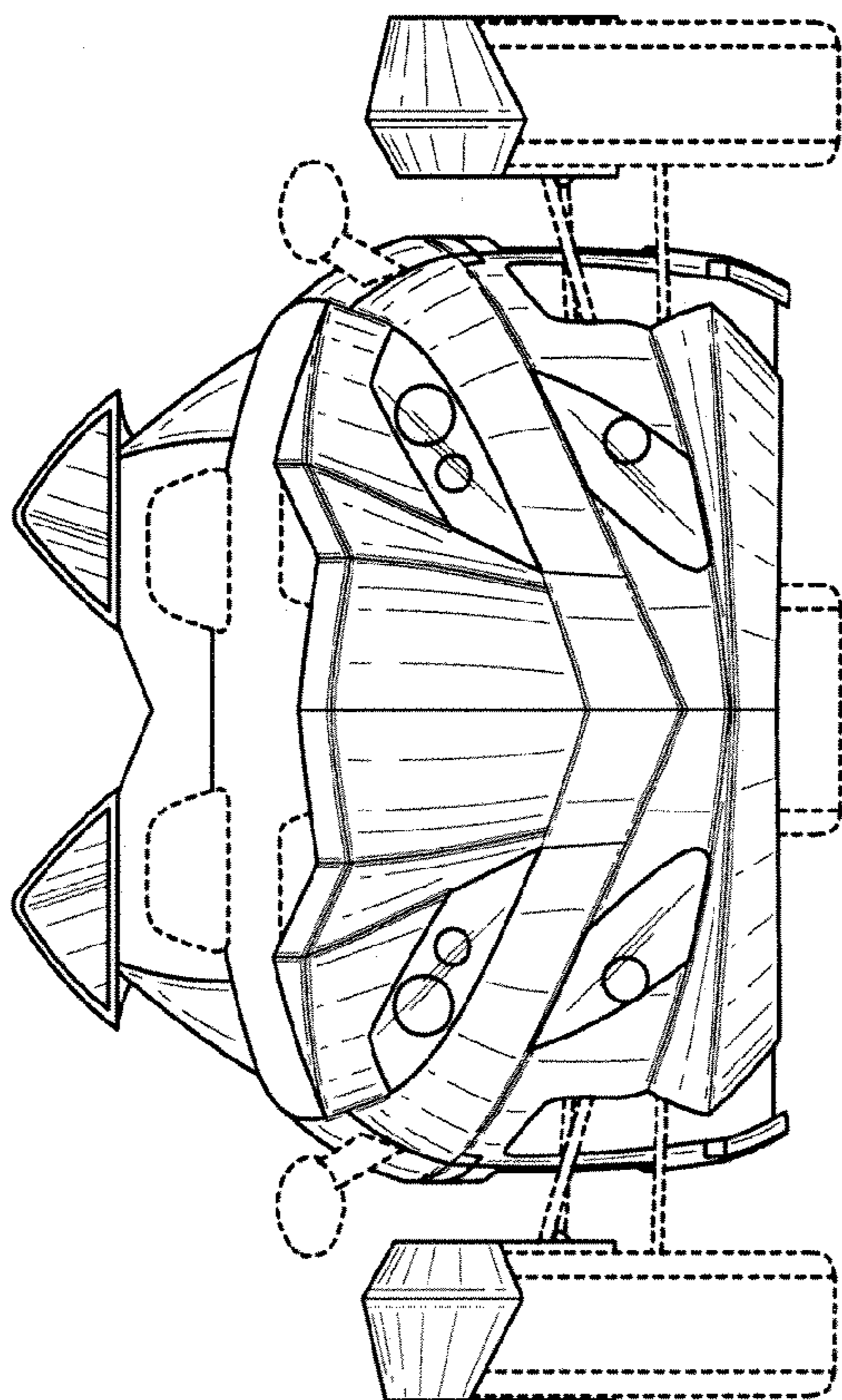


**FIG. 2**

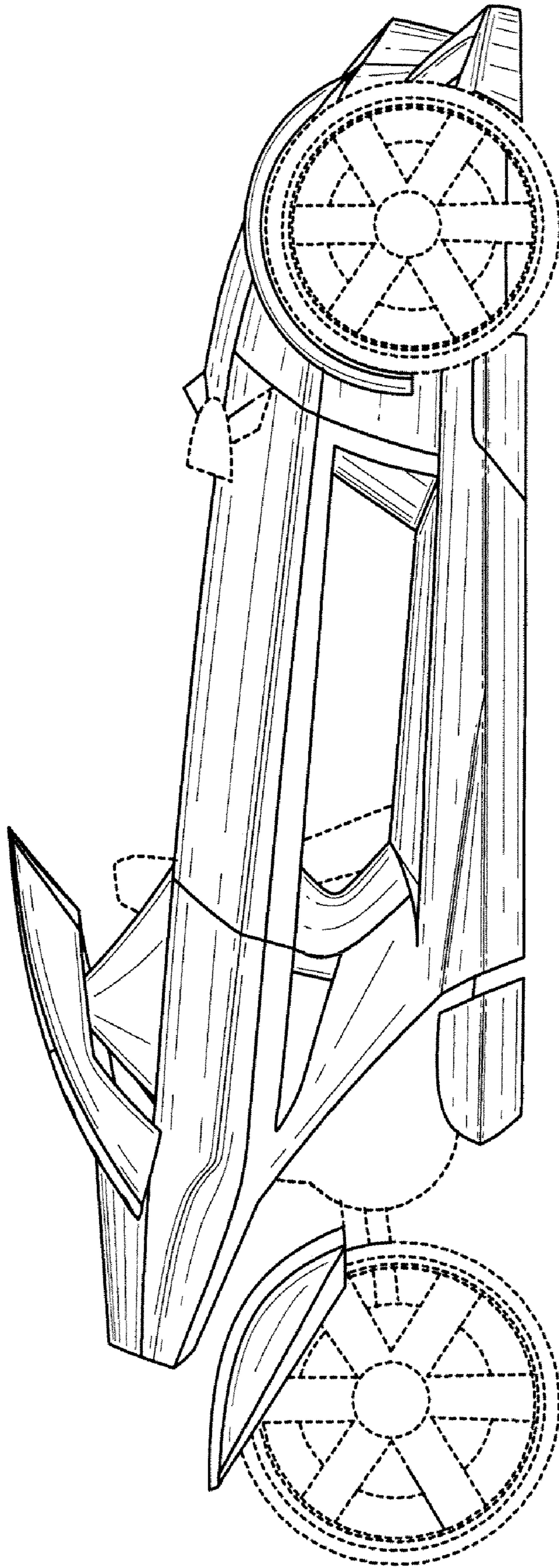




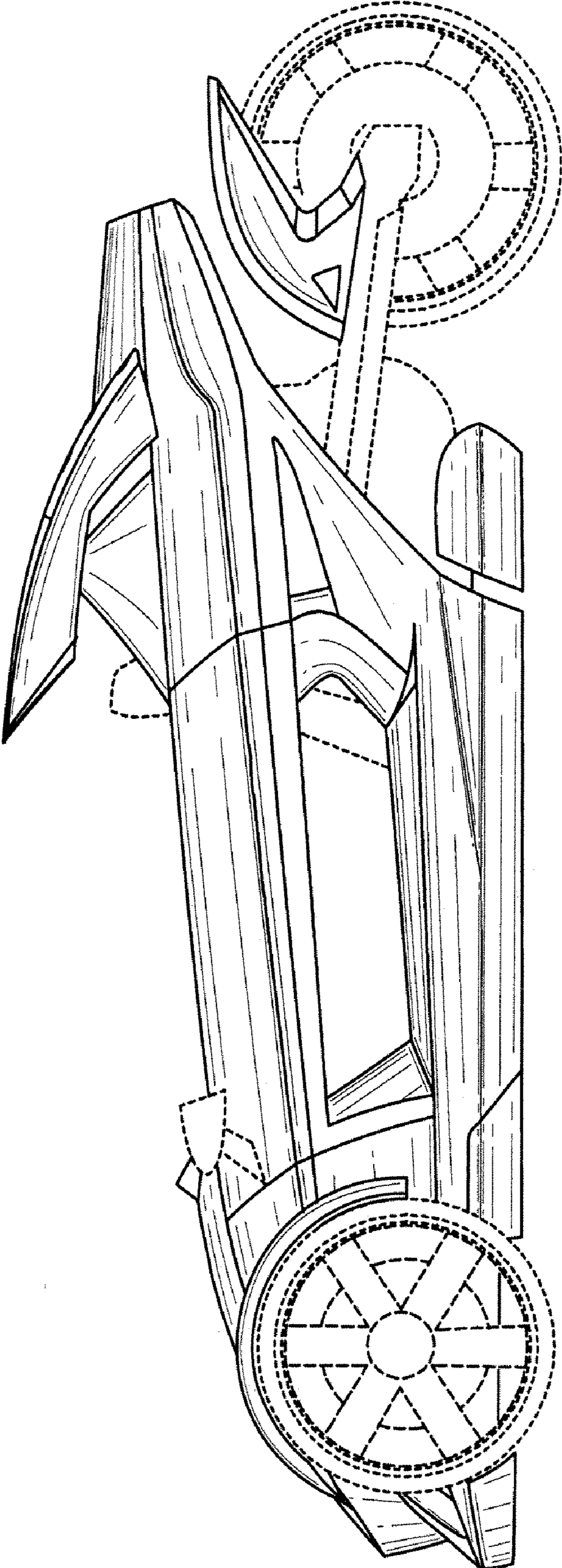
**FIG. 3**



**FIG. 4**

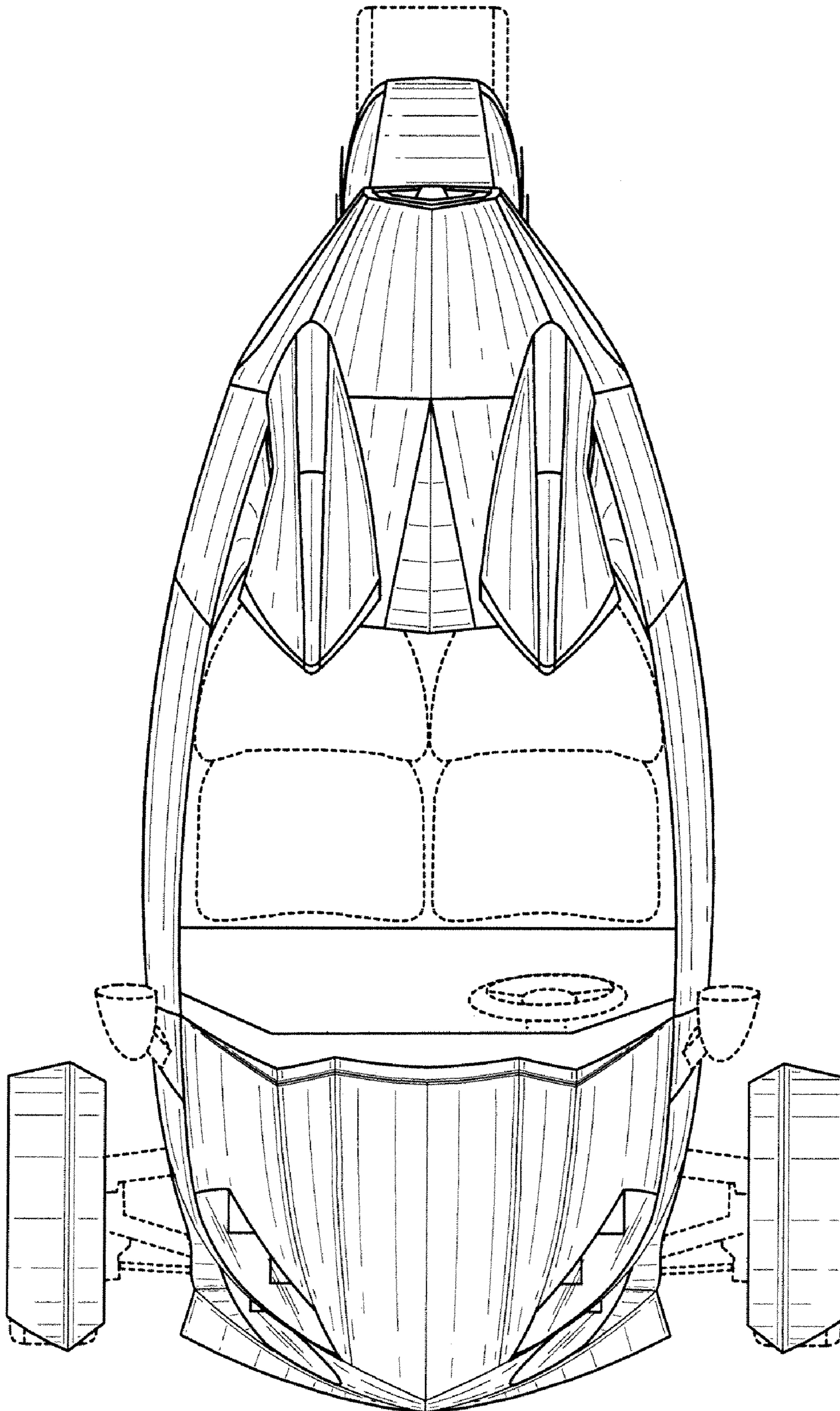


**FIG. 5**



**FIG. 6**





**FIG. 7**