



US00D589427S

(12) **United States Design Patent**  
**Scheu**

(10) **Patent No.:** **US D589,427 S**  
(45) **Date of Patent:** **\*\* Mar. 31, 2009**

(54) **FRONT FACE OF A VEHICLE WHEEL**

(75) Inventor: **Armin Scheu**, Stuttgart (DE)

(73) Assignee: **Daimler AG**, Stuttgart (DE)

(\*\*) Term: **14 Years**

(21) Appl. No.: **29/290,692**

(22) Filed: **Jan. 3, 2008**

(30) **Foreign Application Priority Data**

Jul. 4, 2007 (EM) ..... 000751722-0002

(51) **LOC (9) Cl.** ..... **12-16**

(52) **U.S. Cl.** ..... **D12/211**

(58) **Field of Classification Search** ..... D12/204-213;  
301/37.101, 64.101, 65, 64.201

See application file for complete search history.

(56) **References Cited**

**U.S. PATENT DOCUMENTS**

D402,952 S \* 12/1998 Sycha ..... D12/211  
D504,100 S \* 4/2005 Pollmann ..... D12/211  
D530,259 S \* 10/2006 Sands ..... D12/211

D533,826 S \* 12/2006 Scheu ..... D12/211  
D570,762 S \* 6/2008 Scheu ..... D12/211  
D572,650 S \* 7/2008 Scheu ..... D12/211  
D579,397 S \* 10/2008 Osborne ..... D12/211

\* cited by examiner

*Primary Examiner*—Stacia Cadmus

(74) *Attorney, Agent, or Firm*—Crowell & Moring LLP

(57) **CLAIM**

The ornamental design for a front face of a vehicle wheel, as shown and described.

**DESCRIPTION**

FIG. 1 is a front view of a first embodiment of a front face of a vehicle wheel according to my novel design; and

FIG. 2 is a perspective view thereof.

FIG. 3 is a front view of a second embodiment of the front face of a vehicle wheel according to my novel design; and,

FIG. 4 is a perspective view thereof.

The broken line showing of the bolt holes and center cap in the central hub area is included for the purpose of illustrating environment and forms no part of the claimed design.

**1 Claim, 2 Drawing Sheets**

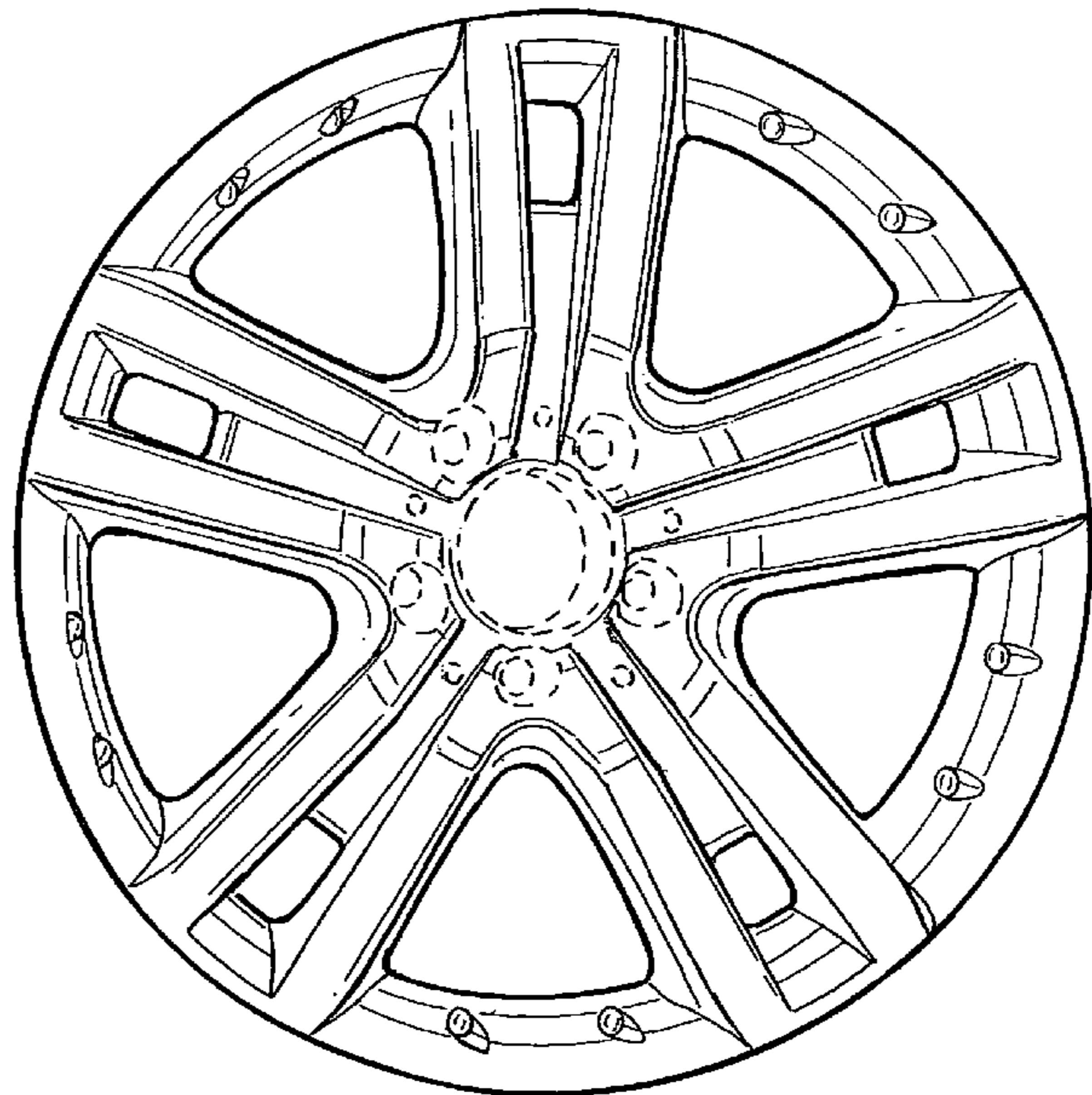
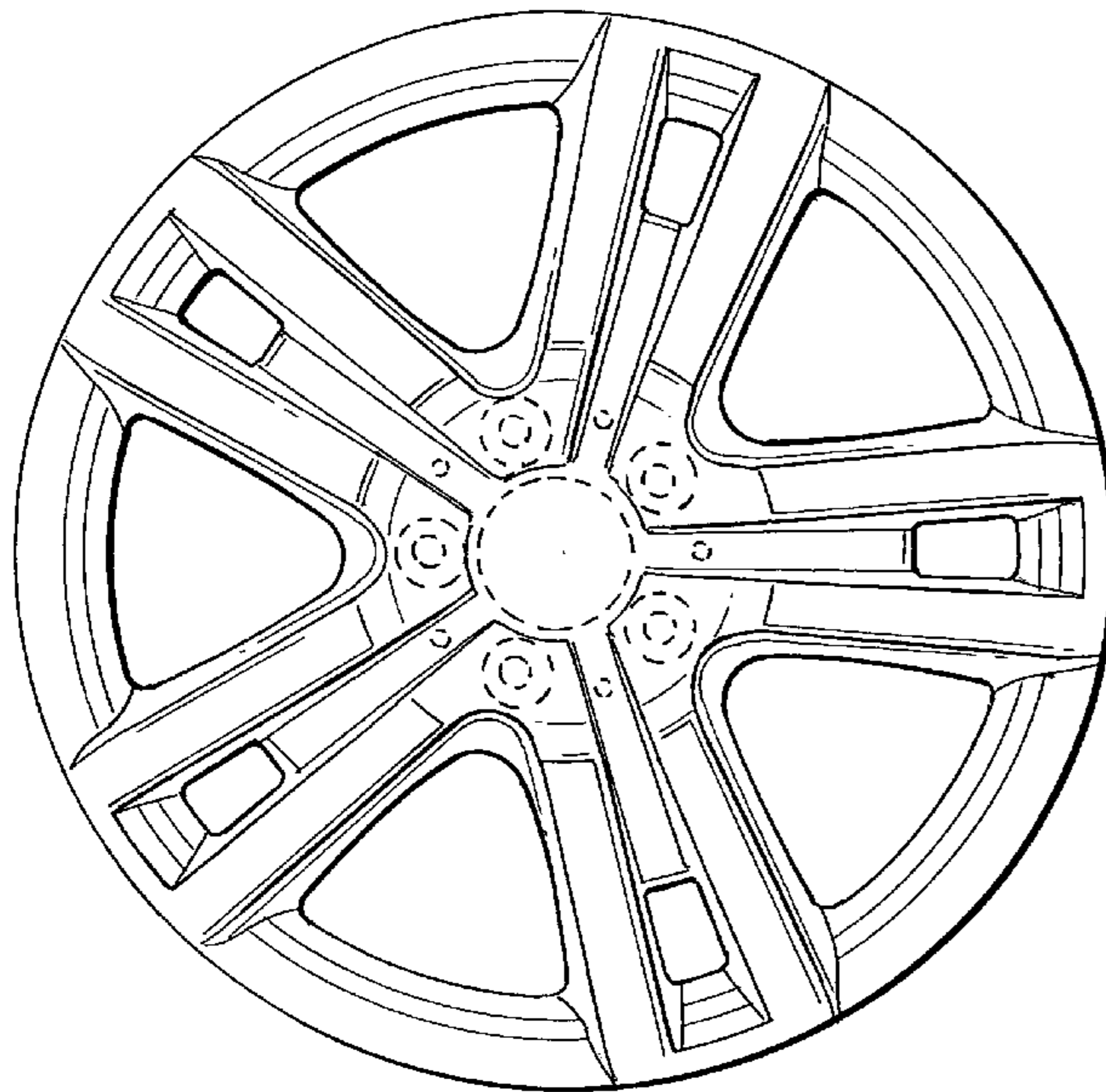

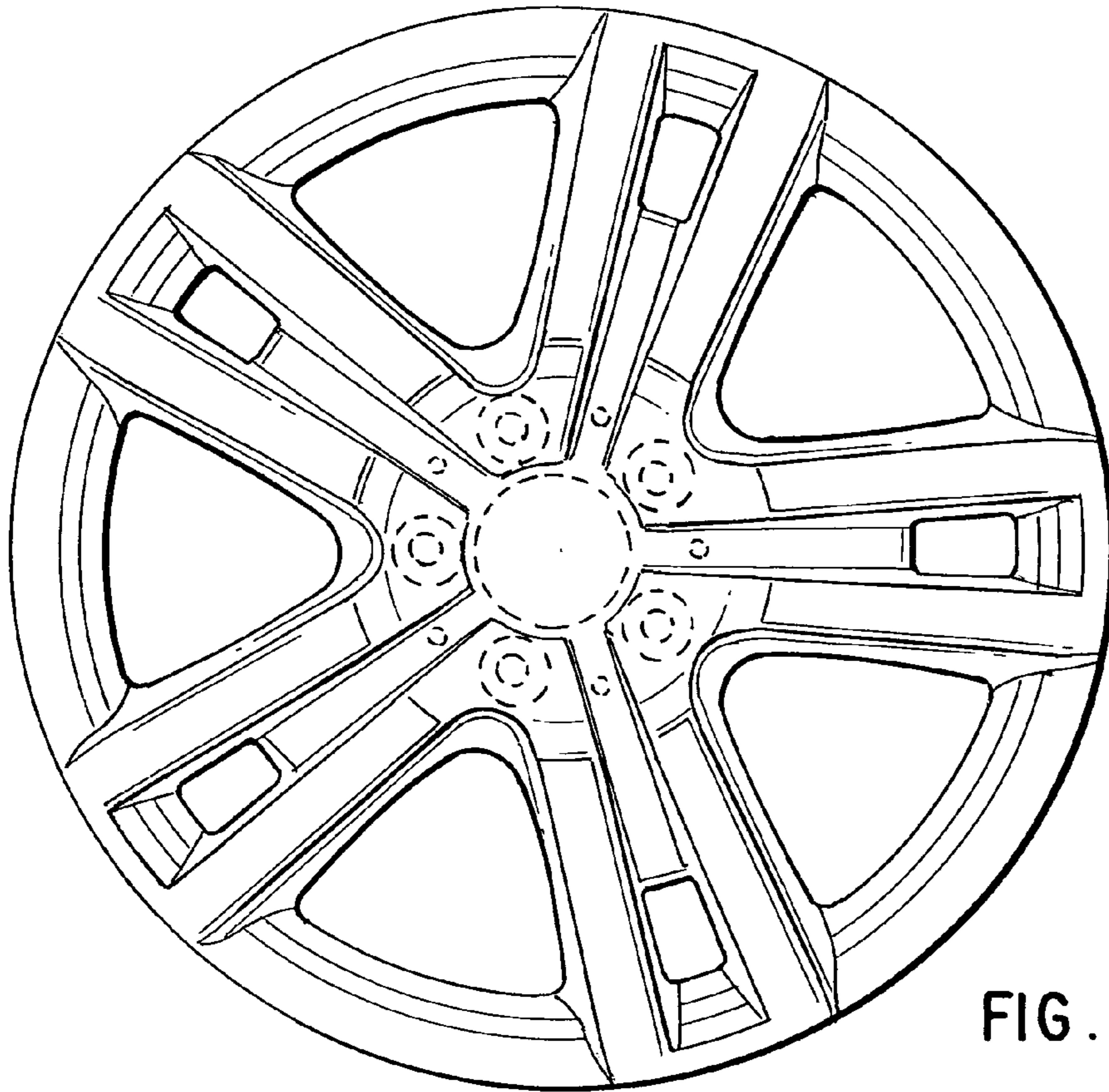

FIG. 1

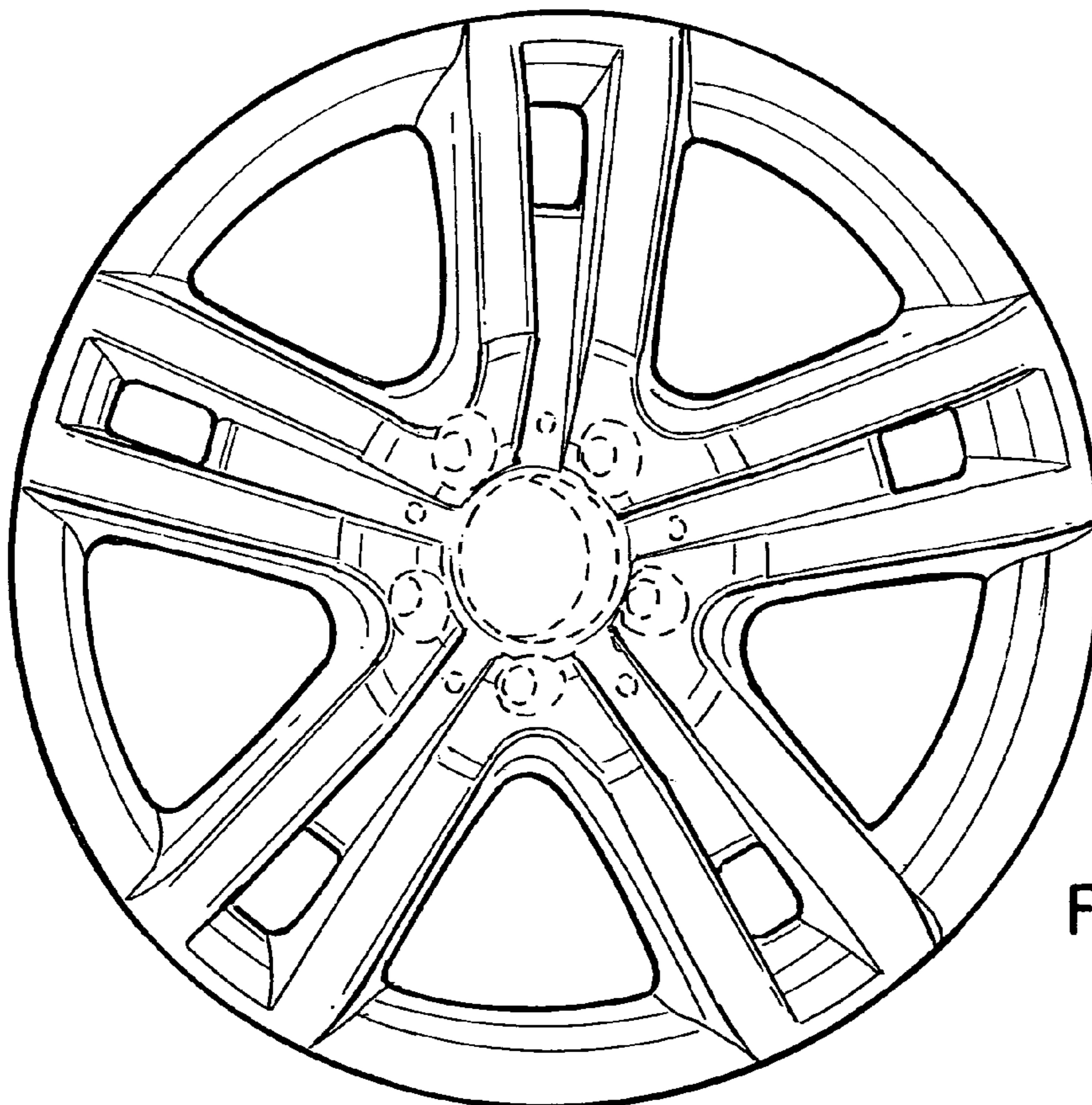

FIG. 2



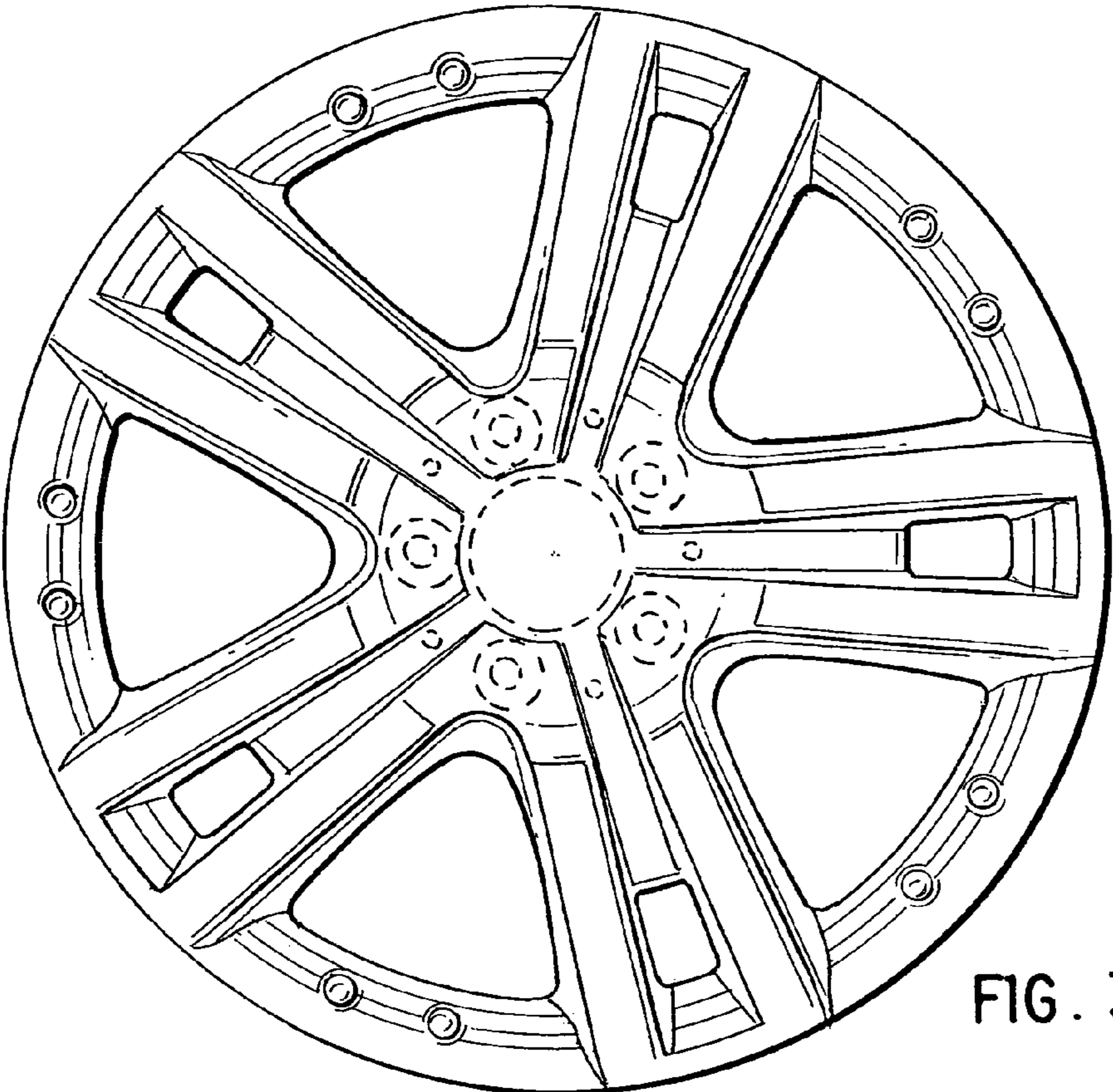

FIG. 3

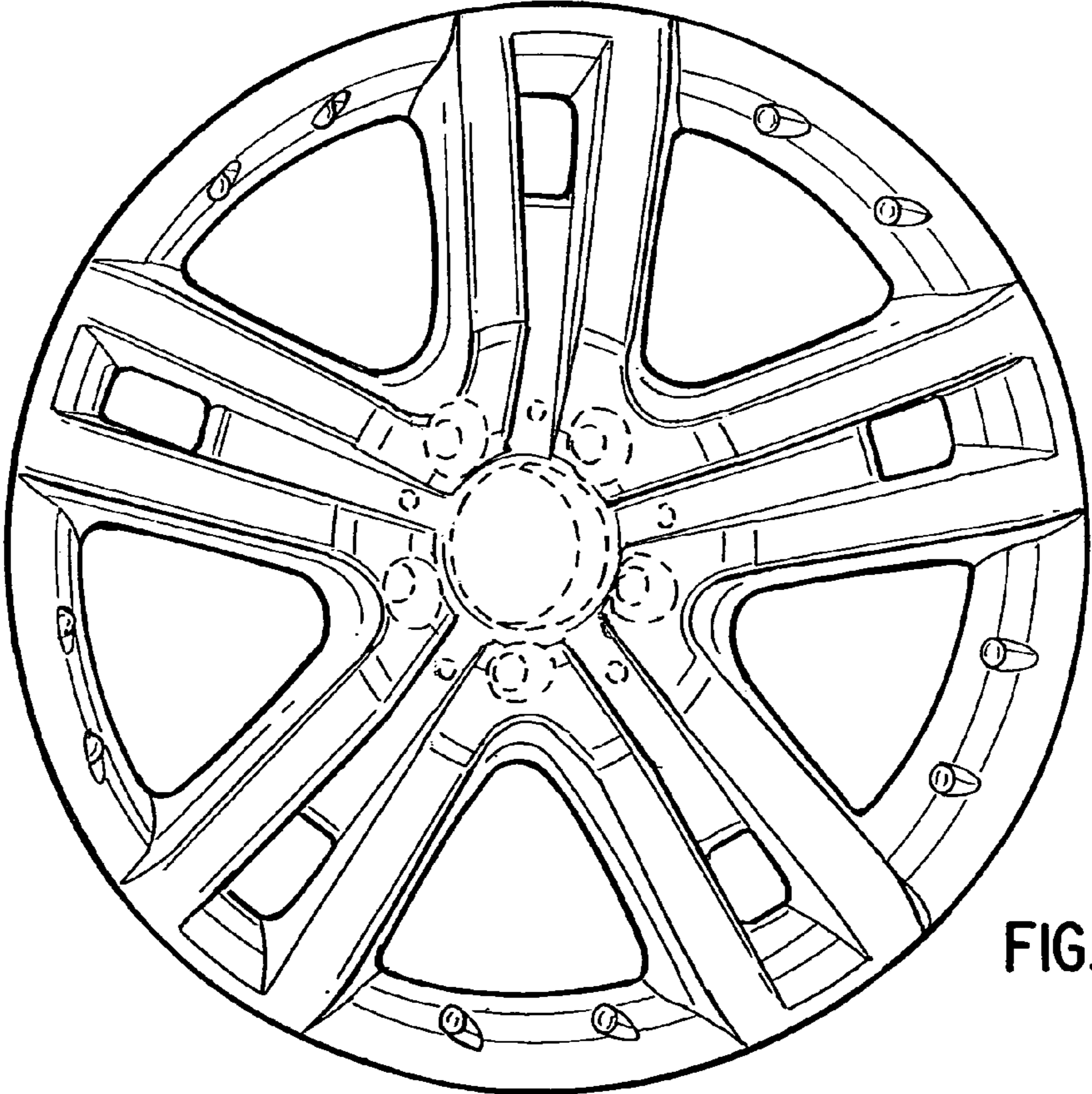

FIG. 4