



US00D589424S

(12) **United States Design Patent**
Futschik et al.

(10) **Patent No.:** **US D589,424 S**

(45) **Date of Patent:** **** Mar. 31, 2009**

(54) **FRONT FACE OF A VEHICLE WHEEL**

(75) Inventors: **Hans-Dieter Futschik**, Gechingen (DE);
Thorsten Klein, Sindelfingen (DE);
Frank Spoerle, Leonberg (DE)

(73) Assignee: **Daimler AG**, Stuttgart (DE)

(**) Term: **14 Years**

(21) Appl. No.: **29/290,270**

(22) Filed: **Nov. 13, 2007**

(30) **Foreign Application Priority Data**

May 14, 2007 (EM) 000722376-0005

(51) **LOC (9) Cl.** **12-16**

(52) **U.S. Cl.** **D12/209**

(58) **Field of Classification Search** D12/204-213;
301/37.101, 64.101, 65, 64.201
See application file for complete search history.

(56) **References Cited**

U.S. PATENT DOCUMENTS

D480,348 S * 10/2003 Donikoglu D12/211
D481,664 S * 11/2003 Vian D12/211
D483,313 S * 12/2003 Lenz D12/209
D519,902 S * 5/2006 Pfeiffer D12/209

D522,431 S * 6/2006 Hieke D12/209
D525,183 S * 7/2006 Pfeiffer D12/209
D538,728 S * 3/2007 Pfeiffer D12/209
D540,236 S * 4/2007 Hamano D12/209
D544,426 S * 6/2007 Siler D12/209
D572,185 S * 7/2008 Pollmann D12/211
D579,847 S * 11/2008 Hieke D12/211

* cited by examiner

Primary Examiner—Stacia Cadmus

(74) *Attorney, Agent, or Firm*—Crowell & Moring LLP

(57) **CLAIM**

The ornamental design for a front face of a vehicle wheel, as shown and described.

DESCRIPTION

FIG. 1 is a front view of a first embodiment of a front face of a vehicle wheel according to our novel design; and

FIG. 2 is a perspective view thereof; and,

FIG. 3 is a front view of a second embodiment of the front face of a vehicle wheel according to our novel design; and,

FIG. 4 is a perspective view thereof.

The broken line showing of the bolt holes and center cap in the central hub area is included for the purpose of illustrating environment and forms no part of the claimed design.

1 Claim, 2 Drawing Sheets

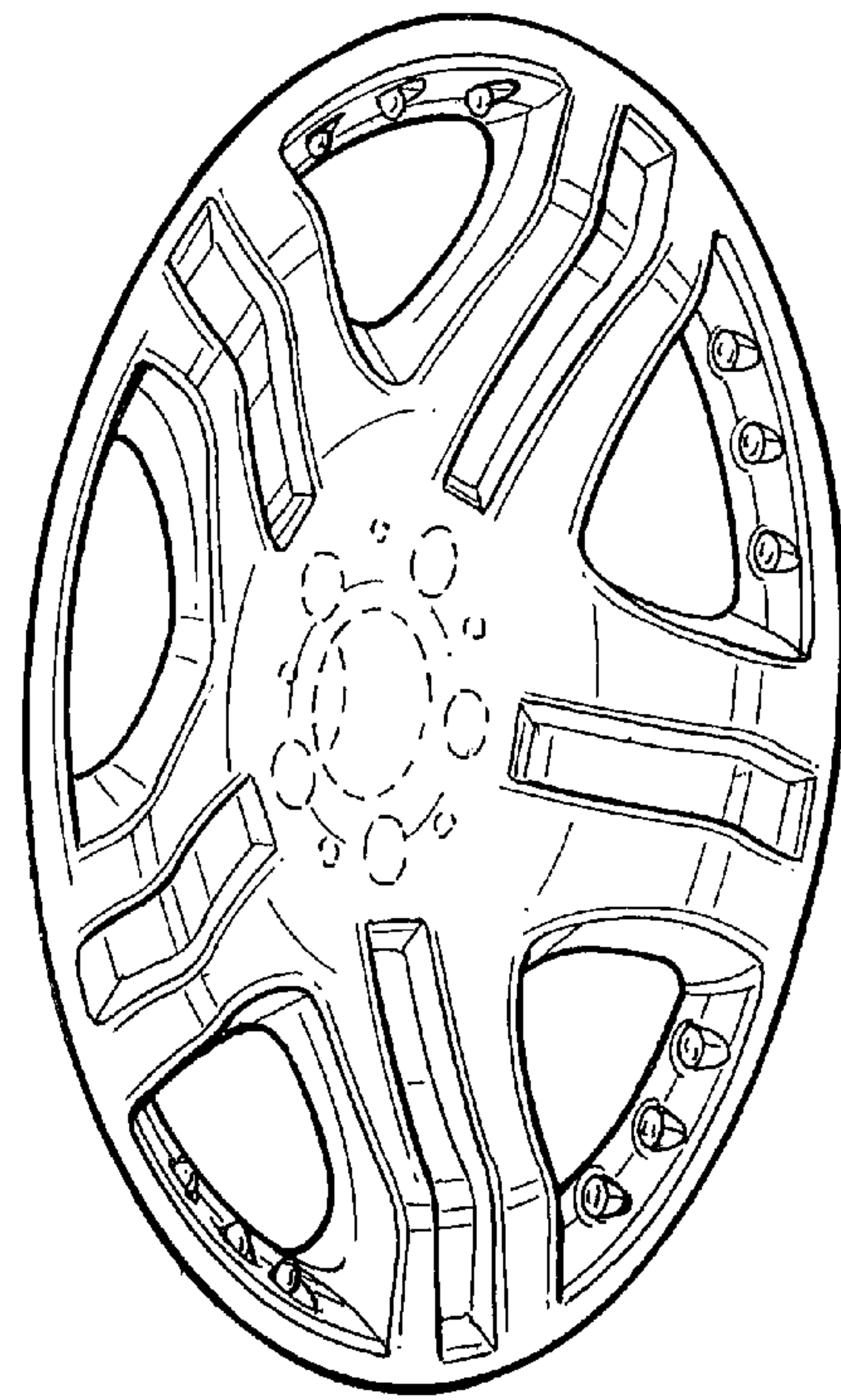
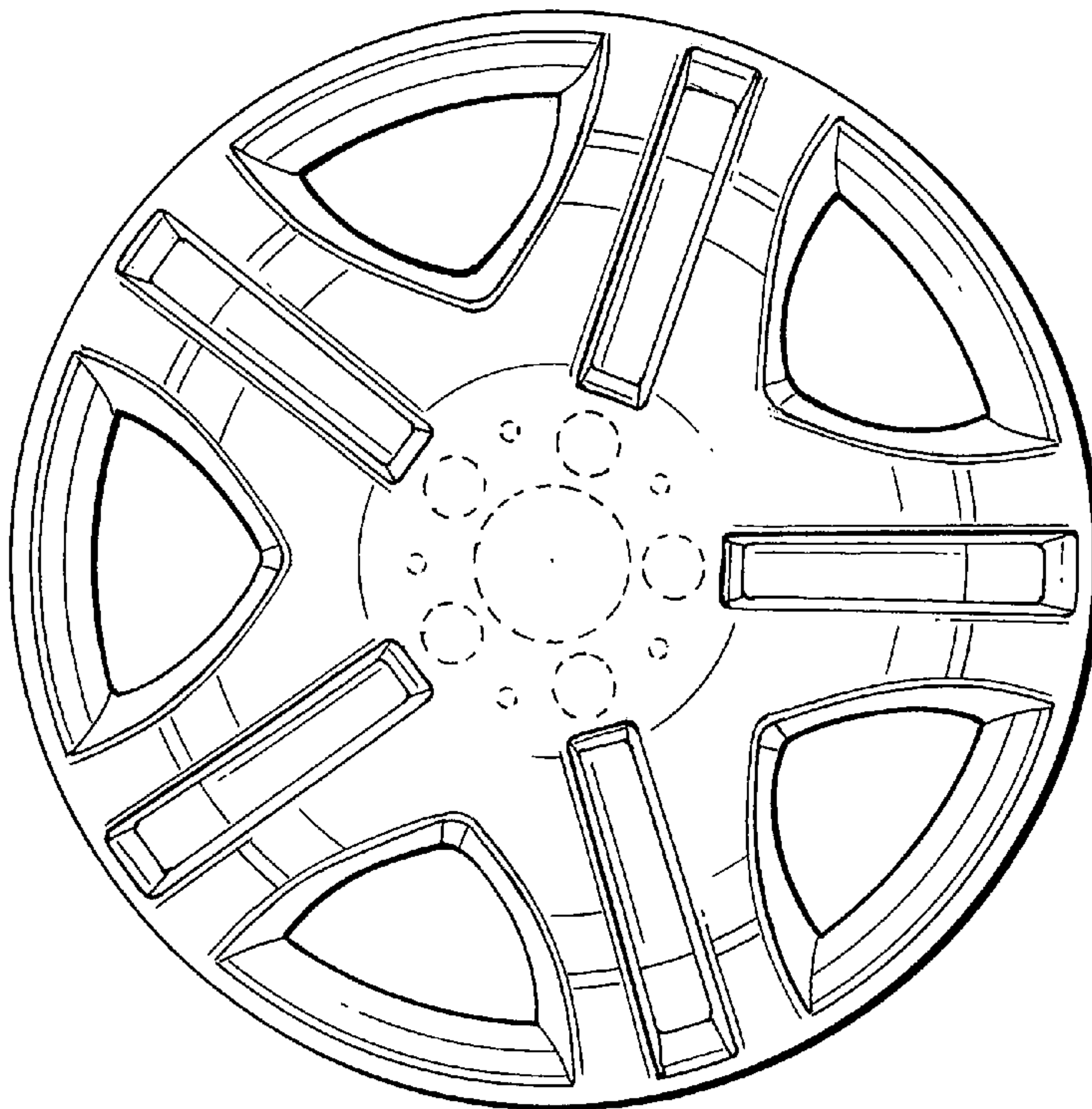

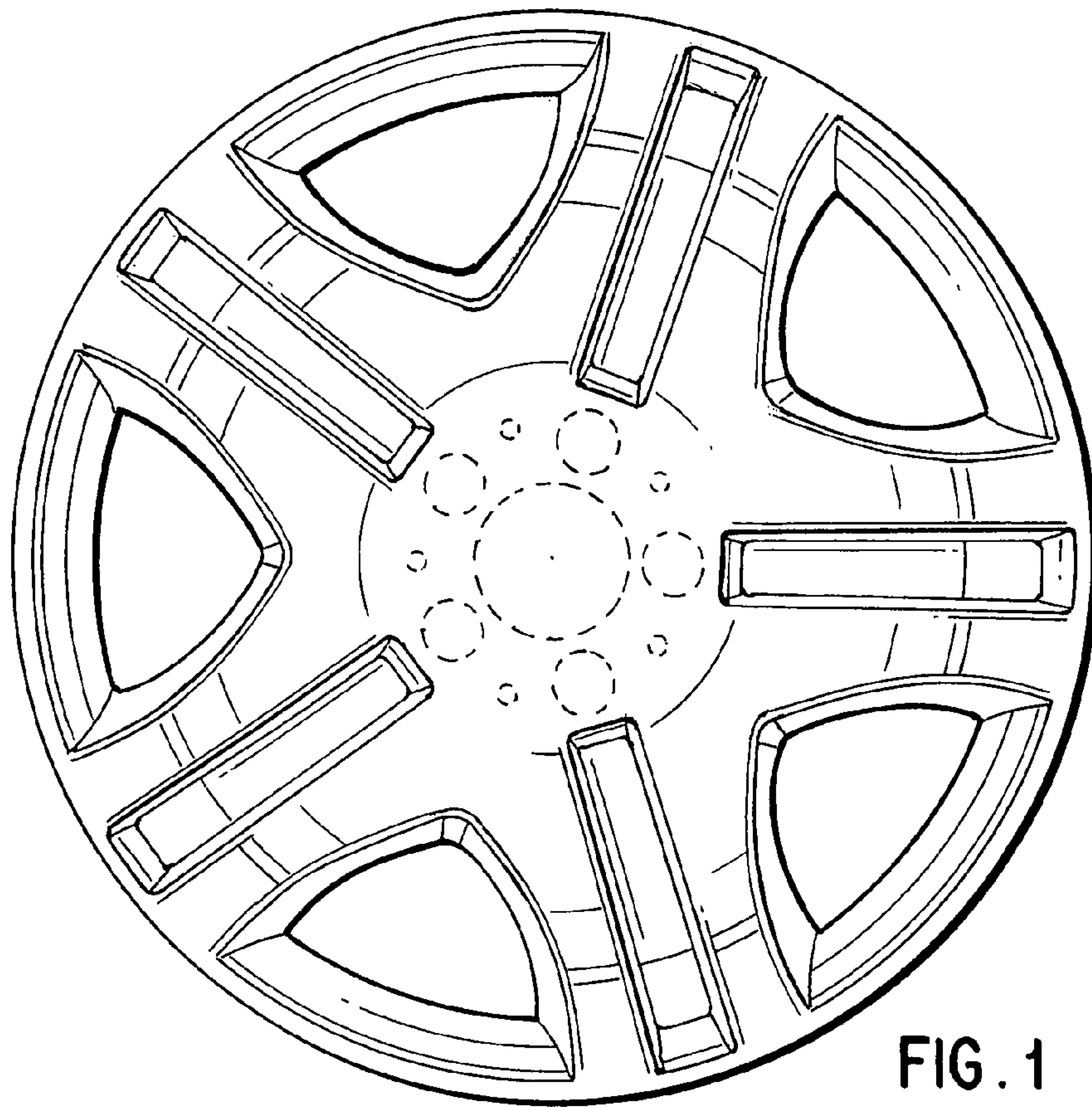

FIG. 1

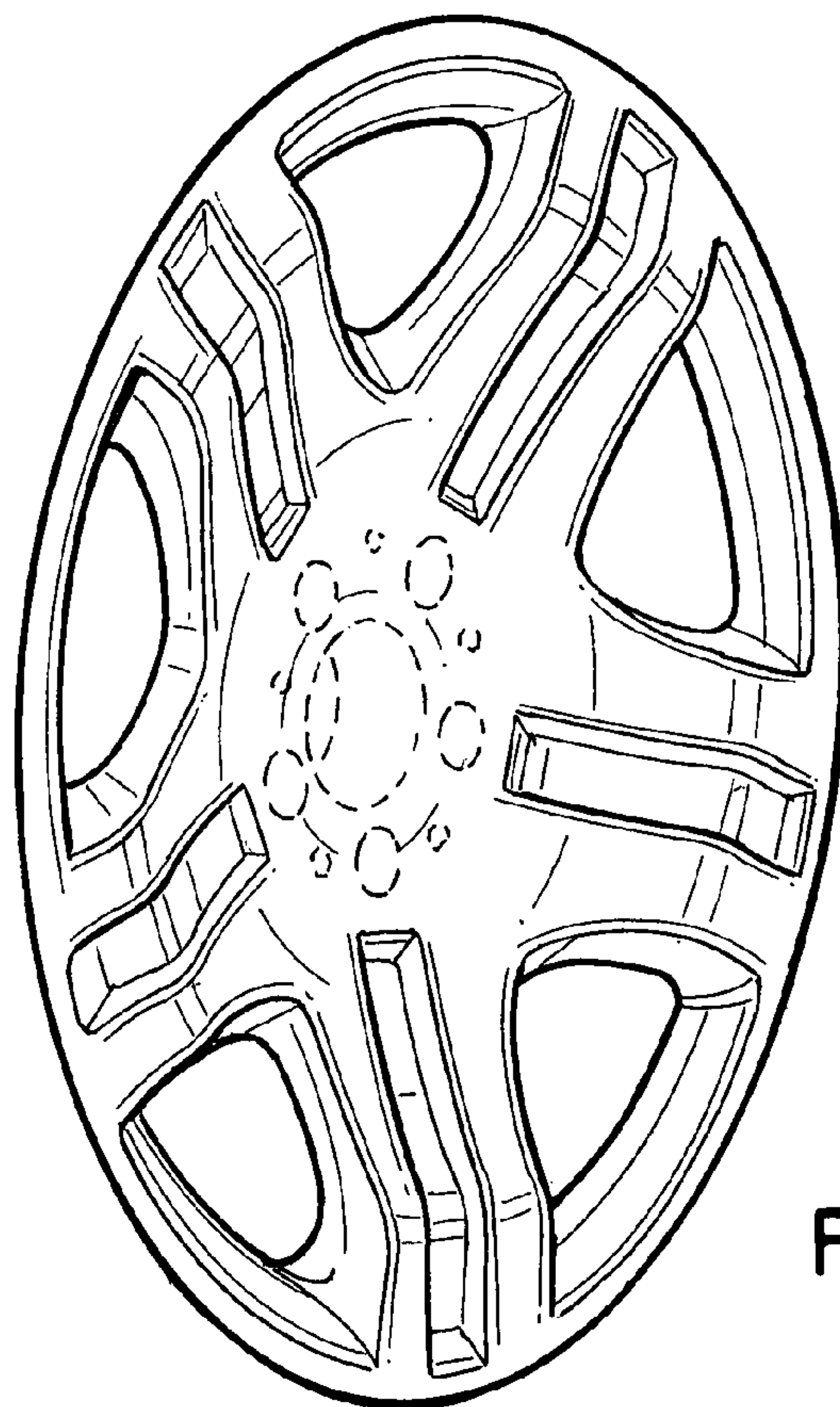

FIG. 2

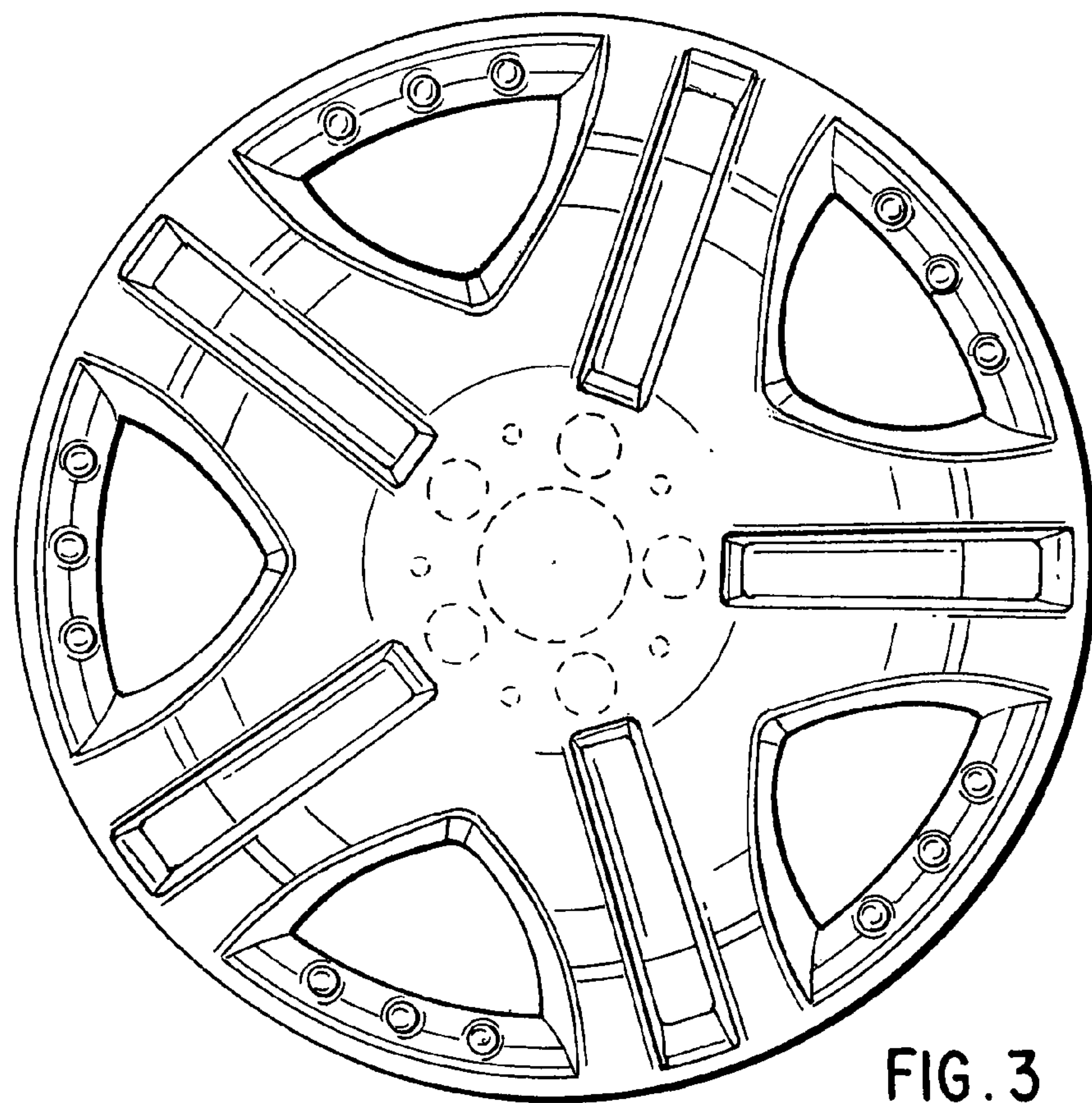

FIG. 3

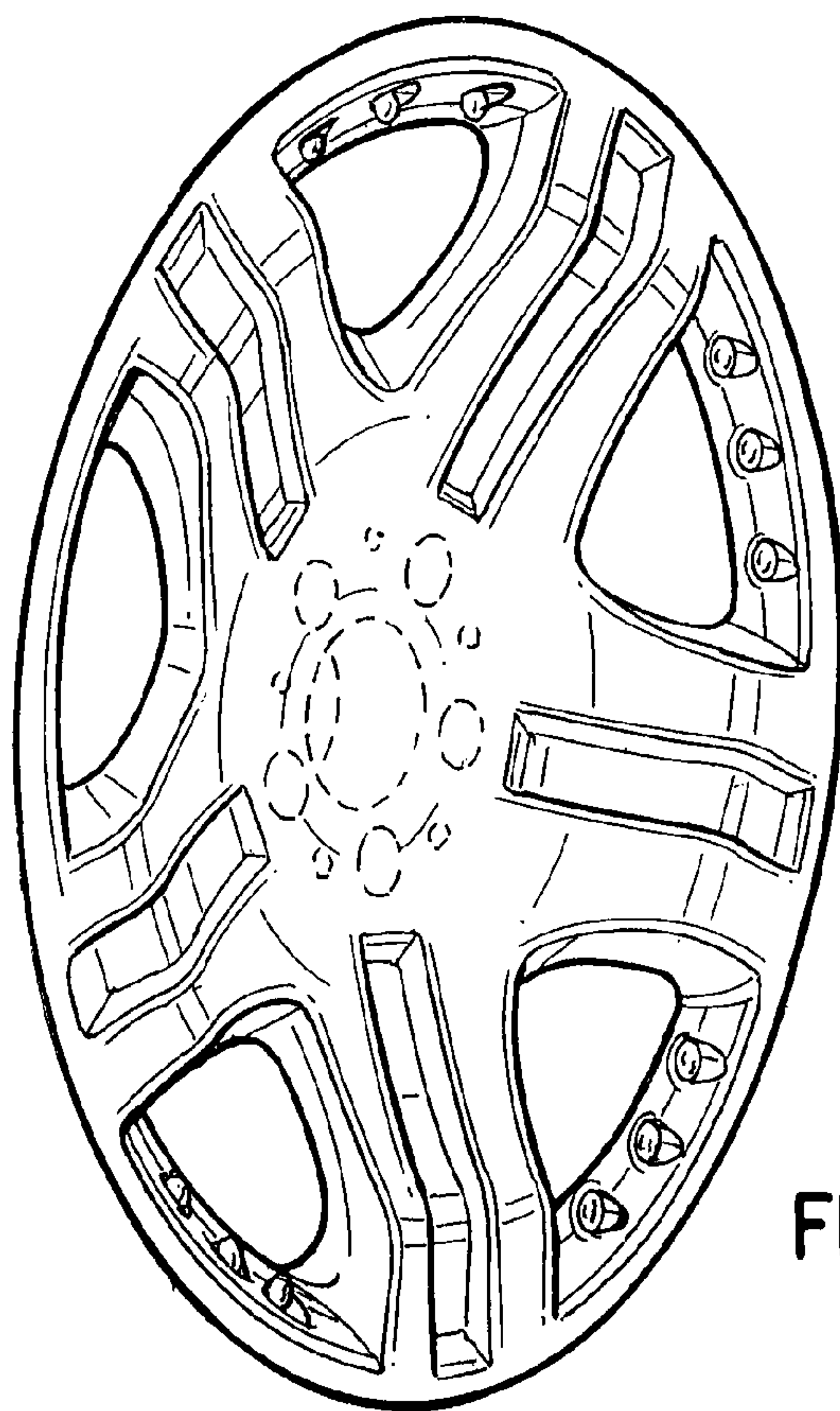

FIG. 4