



US00D589417S

(12) **United States Design Patent**
Osborne et al.

(10) **Patent No.:** **US D589,417 S**
(45) **Date of Patent:** **** Mar. 31, 2009**

(54) **VEHICLE HOOD**

(75) Inventors: **Art Osborne**, San Pedro, CA (US);
Kenneth Snow, Torrance, CA (US)

(73) Assignee: **Honda Motor Co., Ltd.**, Tokyo (JP)

(**) Term: **14 Years**

(21) Appl. No.: **29/323,936**

(22) Filed: **Sep. 3, 2008**

Related U.S. Application Data

(62) Division of application No. 29/304,811, filed on Mar. 7, 2008.

(51) **LOC (9) Cl.** **12-16**

(52) **U.S. Cl.** **D12/173**

(58) **Field of Classification Search** D12/173,
D12/196, 86, 90-92; 180/69.21, 69.2, 69.22
See application file for complete search history.

(56) **References Cited**

U.S. PATENT DOCUMENTS

- D552,519 S * 10/2007 Davidson D12/173
- D560,577 S * 1/2008 Okamoto et al. D12/173
- D561,664 S * 2/2008 Golden et al. D12/173

* cited by examiner

Primary Examiner—Melody N Brown
(74) *Attorney, Agent, or Firm*—Plumsea Law Group, LLC;
Mark E. Duell

(57) **CLAIM**

The ornamental design for a vehicle hood, as shown and described.

DESCRIPTION

FIG. 1 is a perspective view of a vehicle hood showing our new design;

FIG. 2 is top plan view thereof;

FIG. 3 is a side elevational view of one side thereof;

FIG. 4 is a side elevational view of the opposite side thereof;

FIG. 5 is an elevational view thereof;

FIG. 6 is a perspective view thereof shown on a vehicle;

FIG. 7 is a top plan view thereof shown on a vehicle;

FIG. 8 is a side elevational view of one side thereof shown on a vehicle;

FIG. 9 is a side elevational view of the opposite side thereof shown on a vehicle; and,

FIG. 10 is a front elevational view thereof shown on a vehicle.

The broken line showings of the remainder of the vehicle in FIGS. 6-10 form no part of the claimed design.

1 Claim, 7 Drawing Sheets

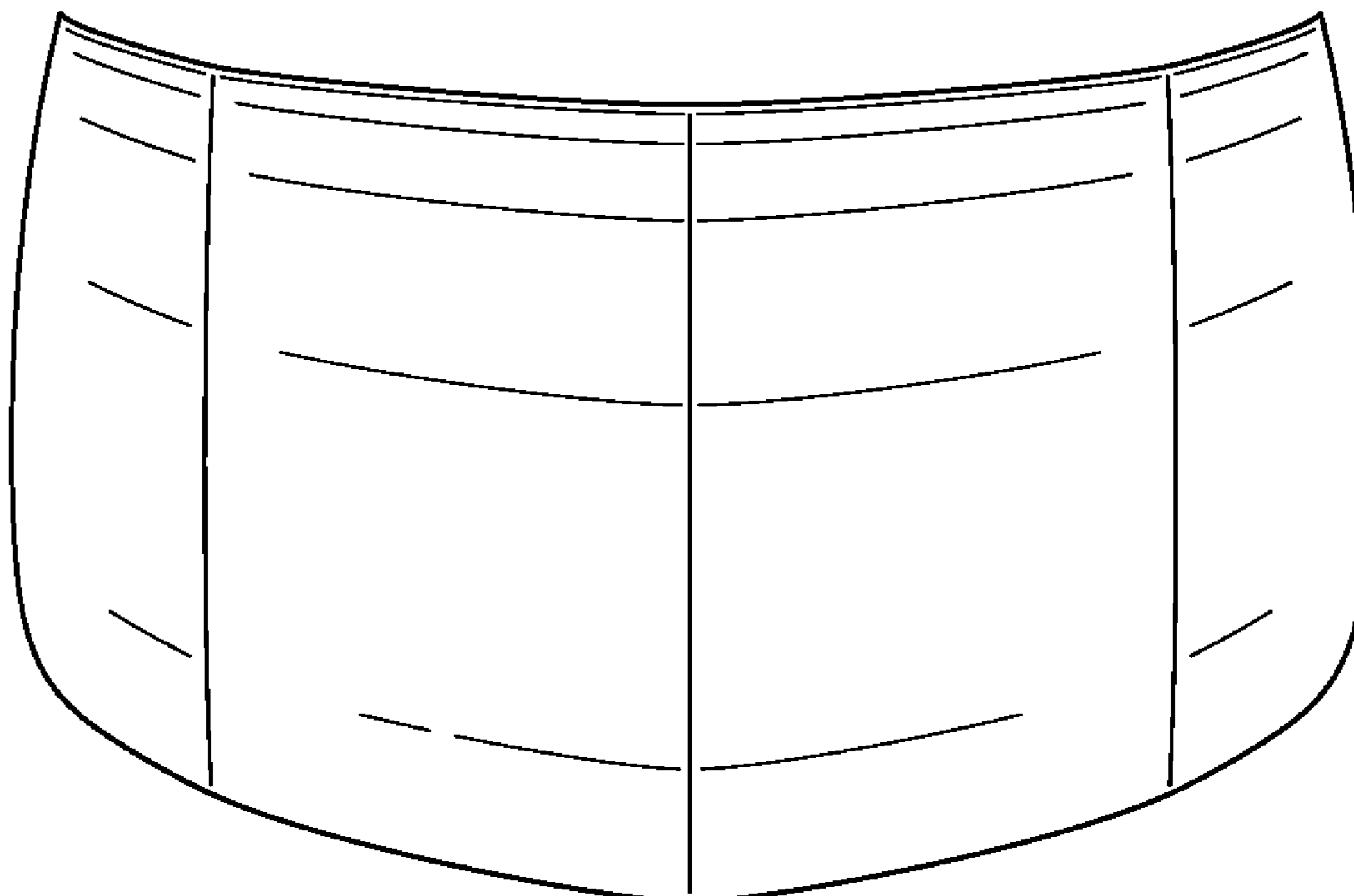

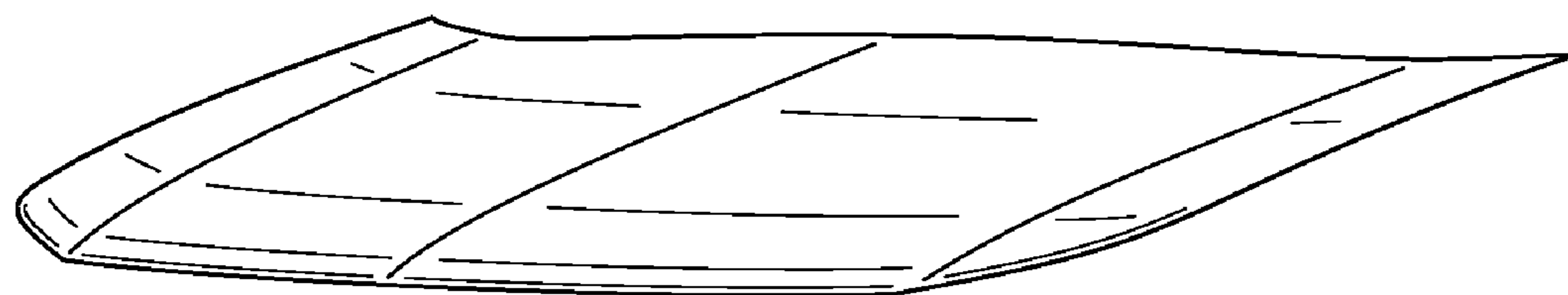

FIG. 1

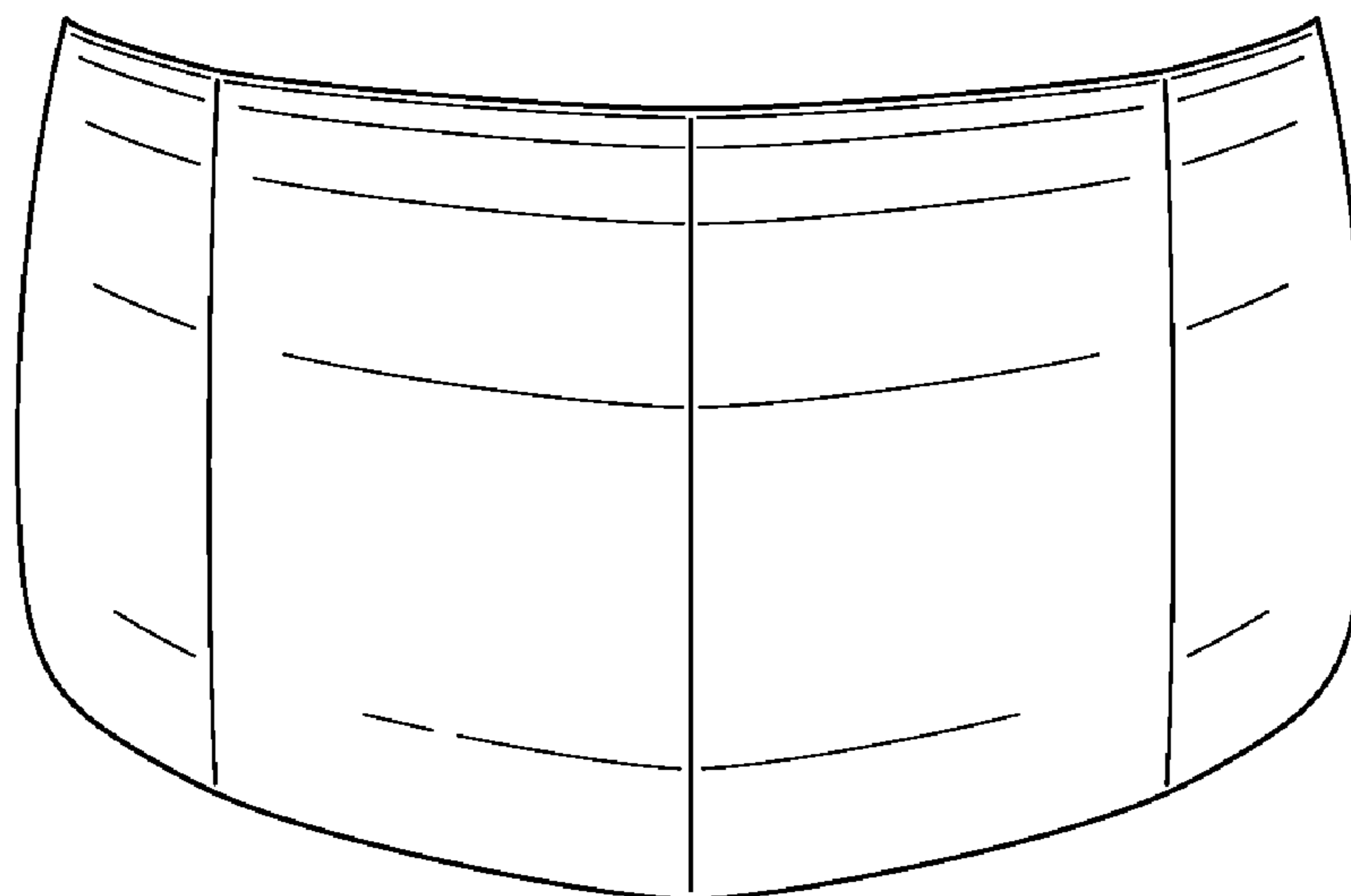

FIG. 2

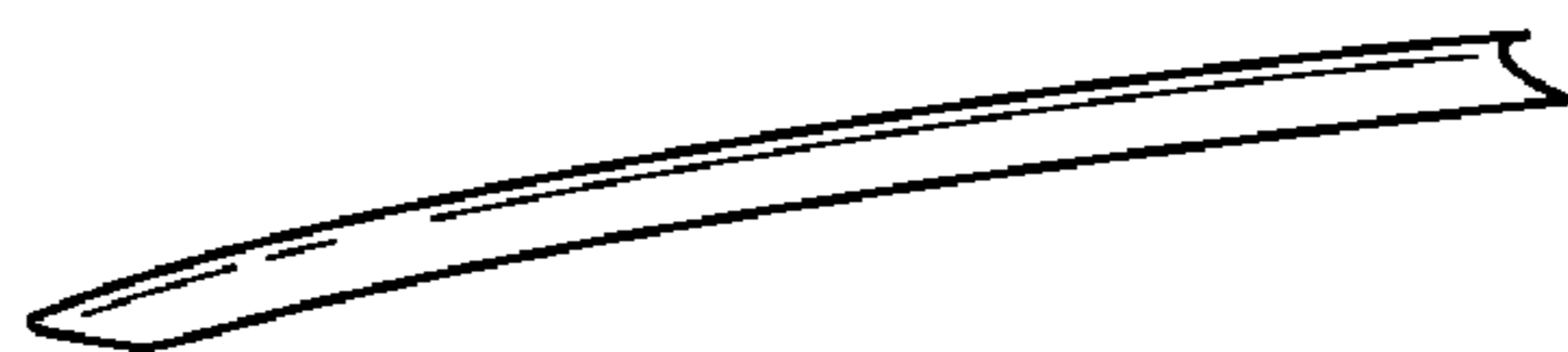

FIG. 3



FIG. 4

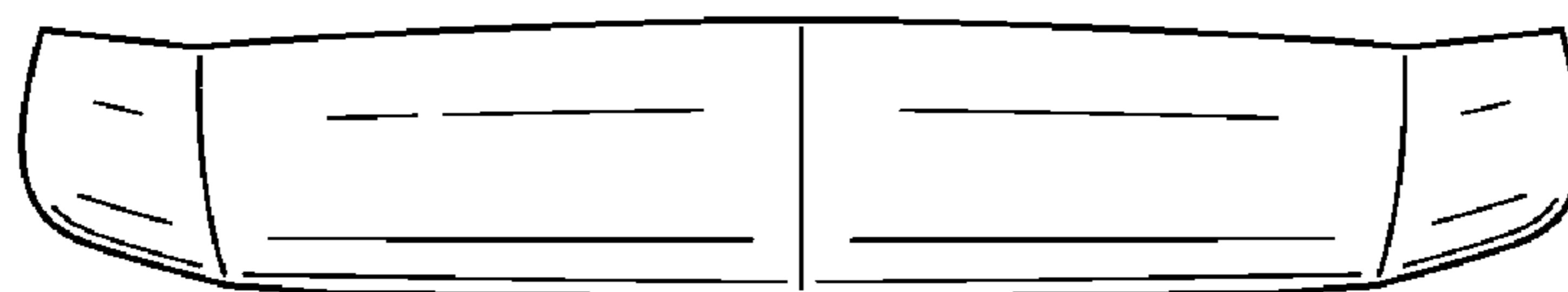

FIG. 5

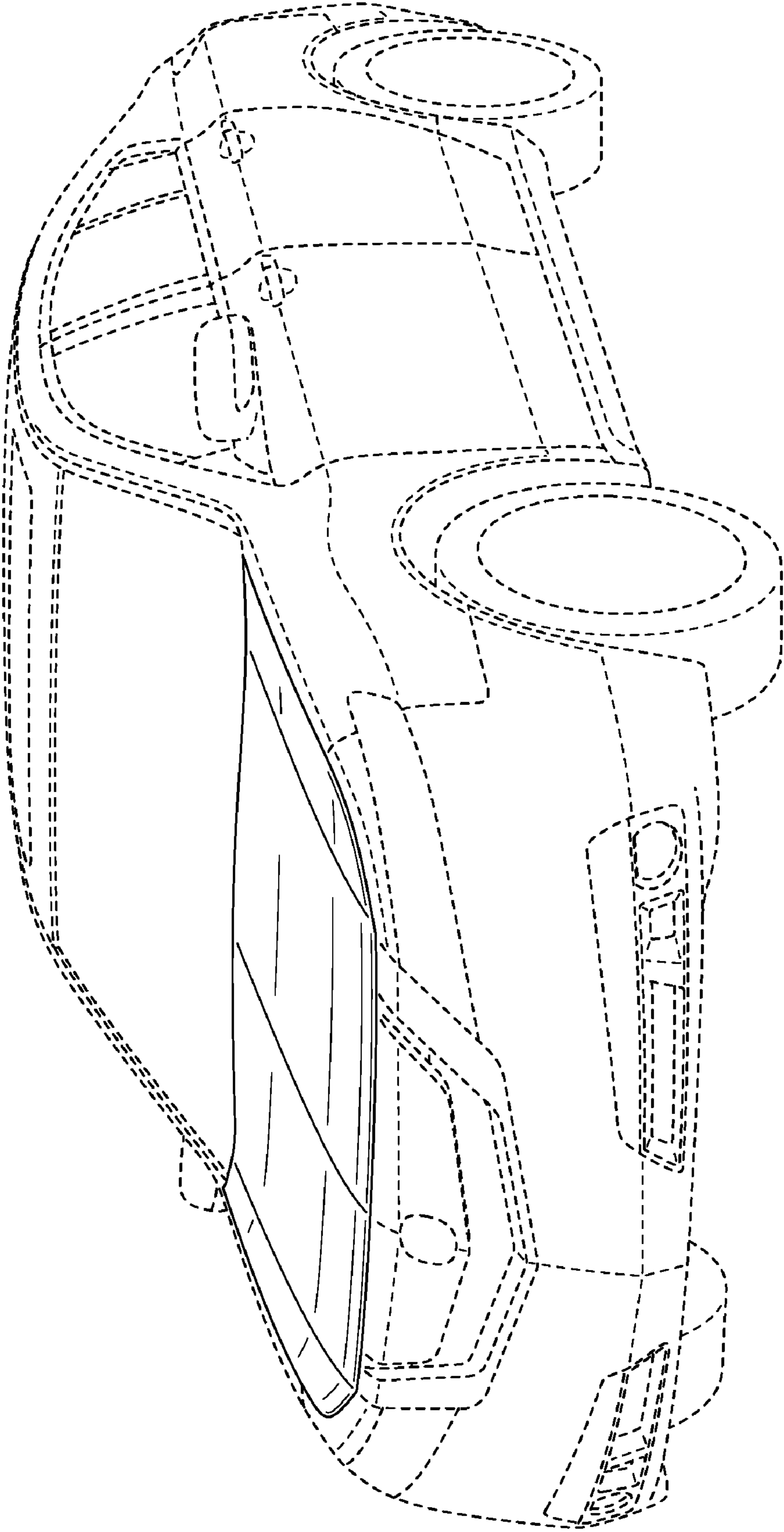

FIG. 6

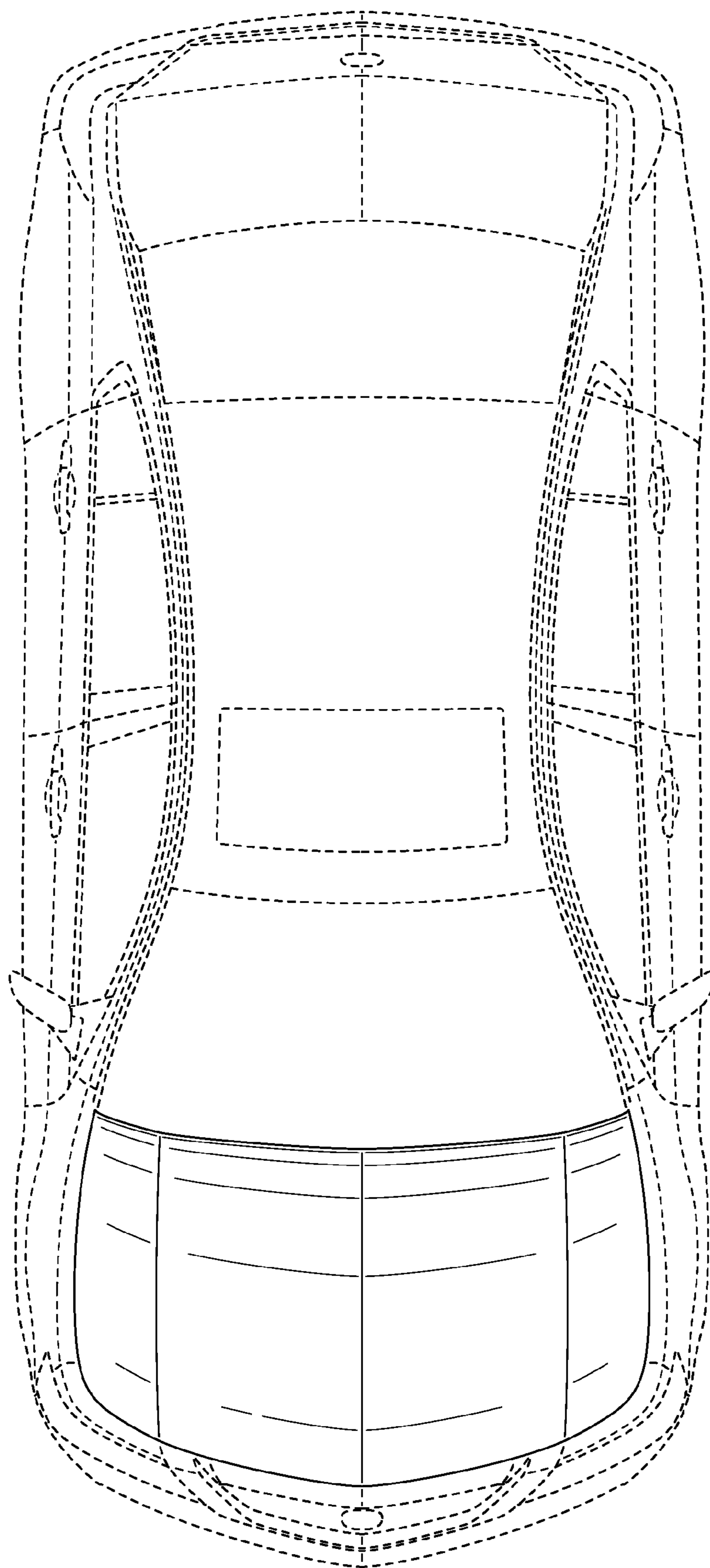

FIG. 7

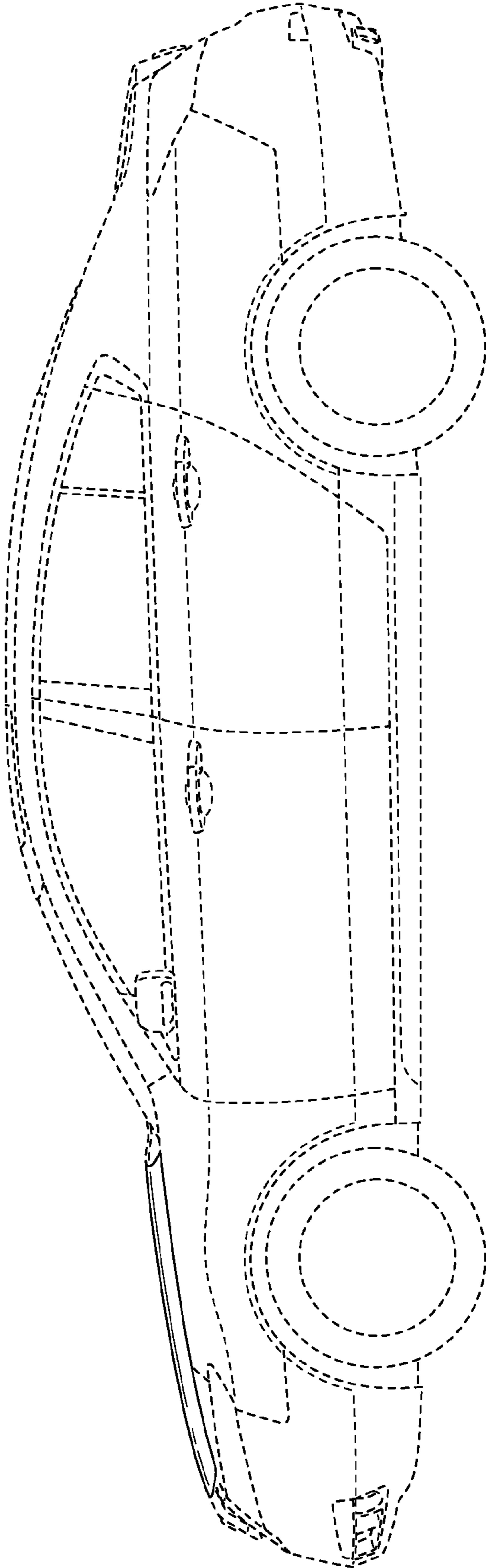

FIG. 8

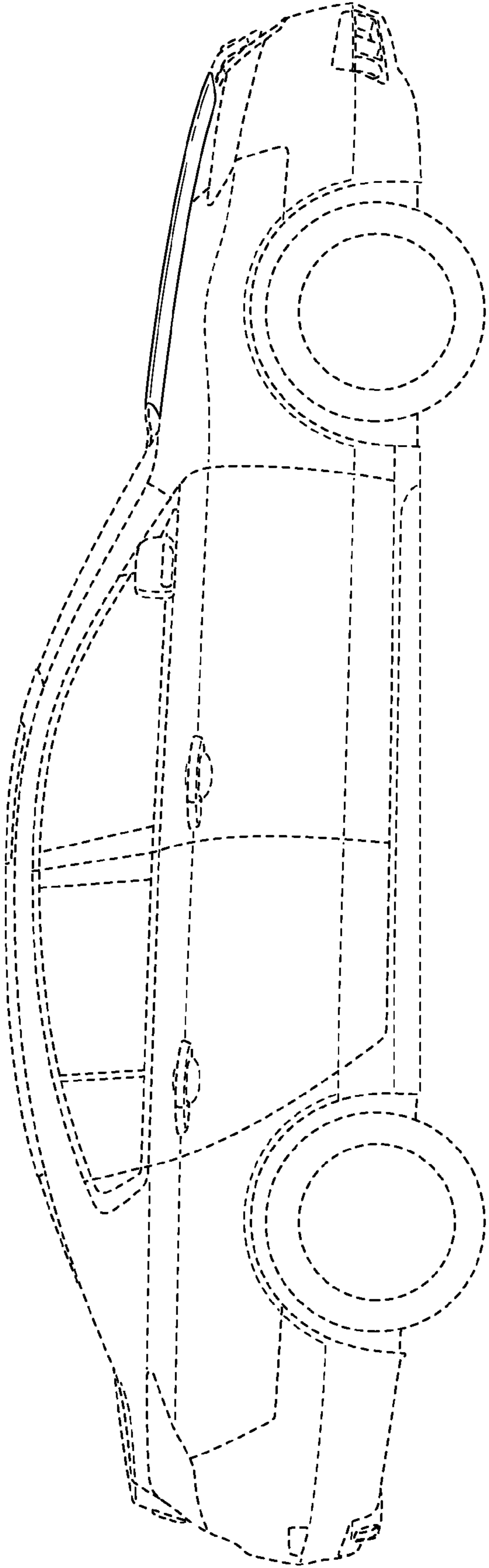

FIG. 9

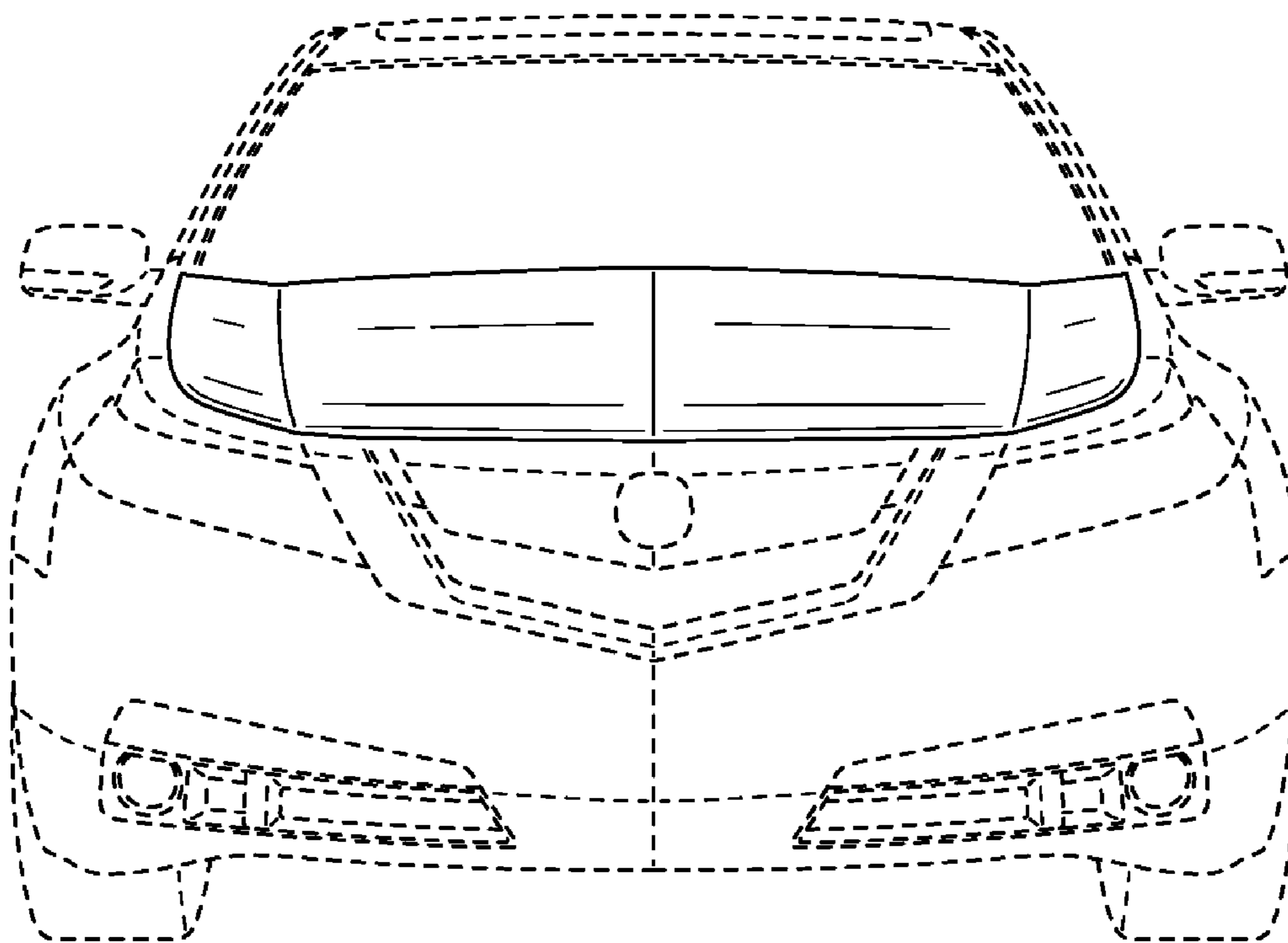

FIG. 10