



US00D588540S

(12) **United States Design Patent**
Barnes, Jr. et al.

(10) **Patent No.:** **US D588,540 S**
(45) **Date of Patent:** **** Mar. 17, 2009**

(54) **ELECTRICAL SOCKET**

(75) Inventors: **Jimmie Barnes, Jr.**, Emporia, KS (US);
David Ihde, Osage City, KS (US)

(73) Assignee: **Hopkins Manufacturing, Inc.**,
Emporia, KS (US)

(**) Term: **14 Years**

(21) Appl. No.: **29/302,189**

(22) Filed: **Jan. 11, 2008**

(51) **LOC (9) Cl.** **13-03**

(52) **U.S. Cl.** **D13/139.1; D13/156**

(58) **Field of Classification Search** D13/139.1,
D13/139.2, 139.3, 139.4, 139.5, 139.6, 139.7,
D13/139.8, 138.1, 138.2, 123, 133, 137.1,
D13/137.2, 184, 137.3, 137.4, 124, 160, 162,
D13/164, 178, 154, 156; D14/433, 256;
D8/350, 353; 174/53, 55, 56, 59, 66, 494,
174/153 G, 152 G, 154, 167, 168, 650, 656;
439/43, 53, 374, 894, 46, 55, 63, 92, 93,
439/95, 101, 102, 105, 106, 107, 108, 135,
439/149, 222, 266, 285, 291, 300, 344, 373,
439/535, 620.21, 638, 660, 907, 650, 651,
439/652, 653, 654

See application file for complete search history.

(56) **References Cited**

U.S. PATENT DOCUMENTS

4,197,959 A * 4/1980 Kramer 220/242
D310,320 S * 9/1990 Domian D8/350
D361,313 S * 8/1995 Sai et al. D13/146
D367,644 S * 3/1996 Fukao D13/146

D367,645 S * 3/1996 Hashizawa et al. D13/146
D372,459 S * 8/1996 Tiberio, Jr. et al. D13/146
D374,212 S * 10/1996 Fukao et al. D13/146
5,582,521 A * 12/1996 Mori et al. 439/142
D399,187 S * 10/1998 Kay 439/142
D410,632 S * 6/1999 Deutsch D13/156
D449,581 S * 10/2001 Bosatelli D13/146
D534,499 S * 1/2007 Park D13/156
D553,306 S * 10/2007 Hansen et al. D13/139.4

* cited by examiner

Primary Examiner—Jennifer Rivard

Assistant Examiner—Angela J Lee

(74) *Attorney, Agent, or Firm*—George R. McGuire; David L.
Nocilly; Bond, Schoeneck & King PLLC

(57) **CLAIM**

The ornamental design for an electrical socket, as shown and described.

DESCRIPTION

FIG. 1 is a perspective view of a new and ornamental design for an electrical socket;

FIG. 2 is a side elevation view thereof; the other side being a mirror image;

FIG. 3 is a front-elevation view thereof;

FIG. 4 is a rear elevation view thereof;

FIG. 5 is a top plan view thereof; and,

FIG. 6 is a bottom plan view thereof.

The broken line showing of portions of an electrical socket is included for the purpose of illustrating environmental structure and forms no part of the claimed design.

1 Claim, 3 Drawing Sheets

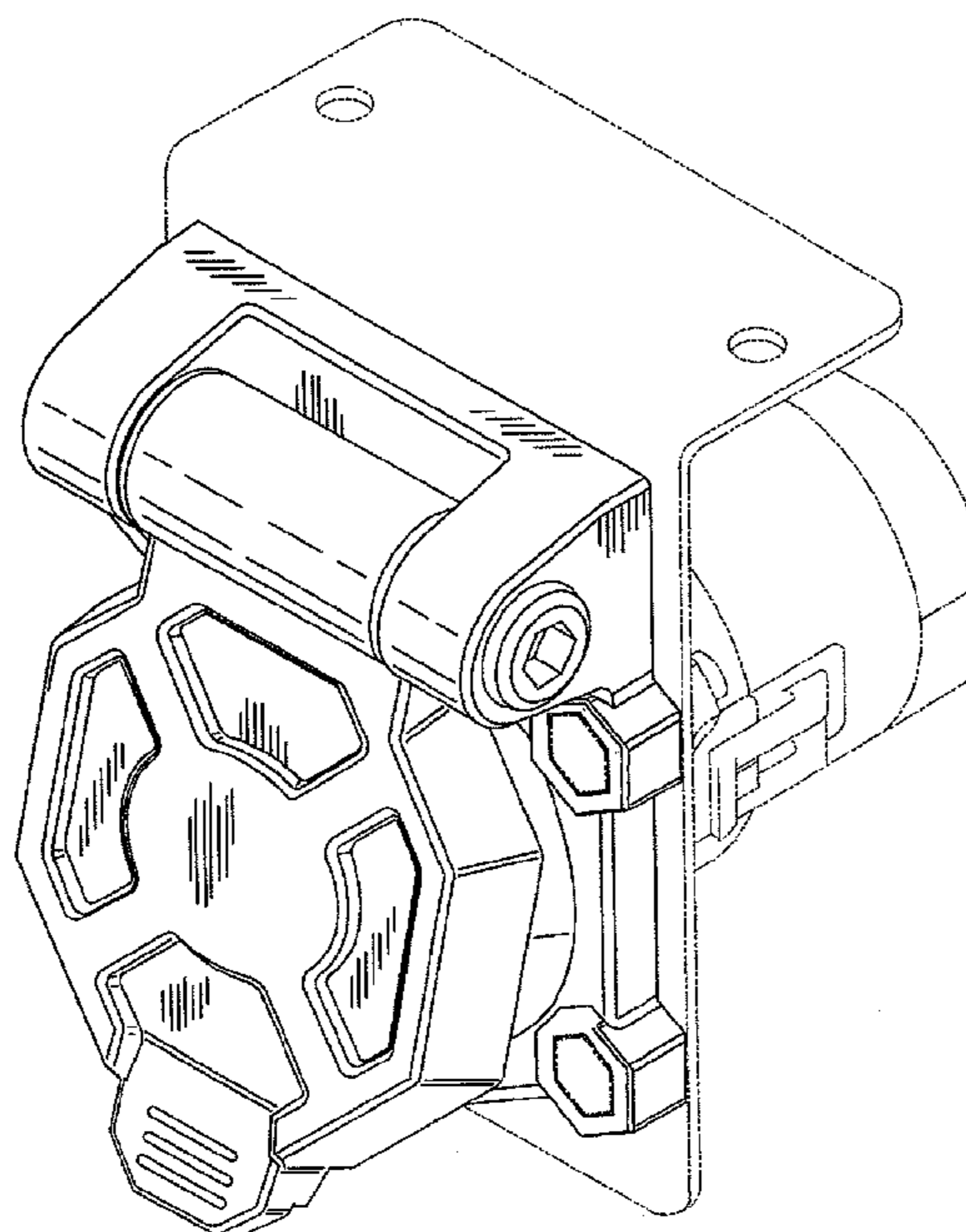

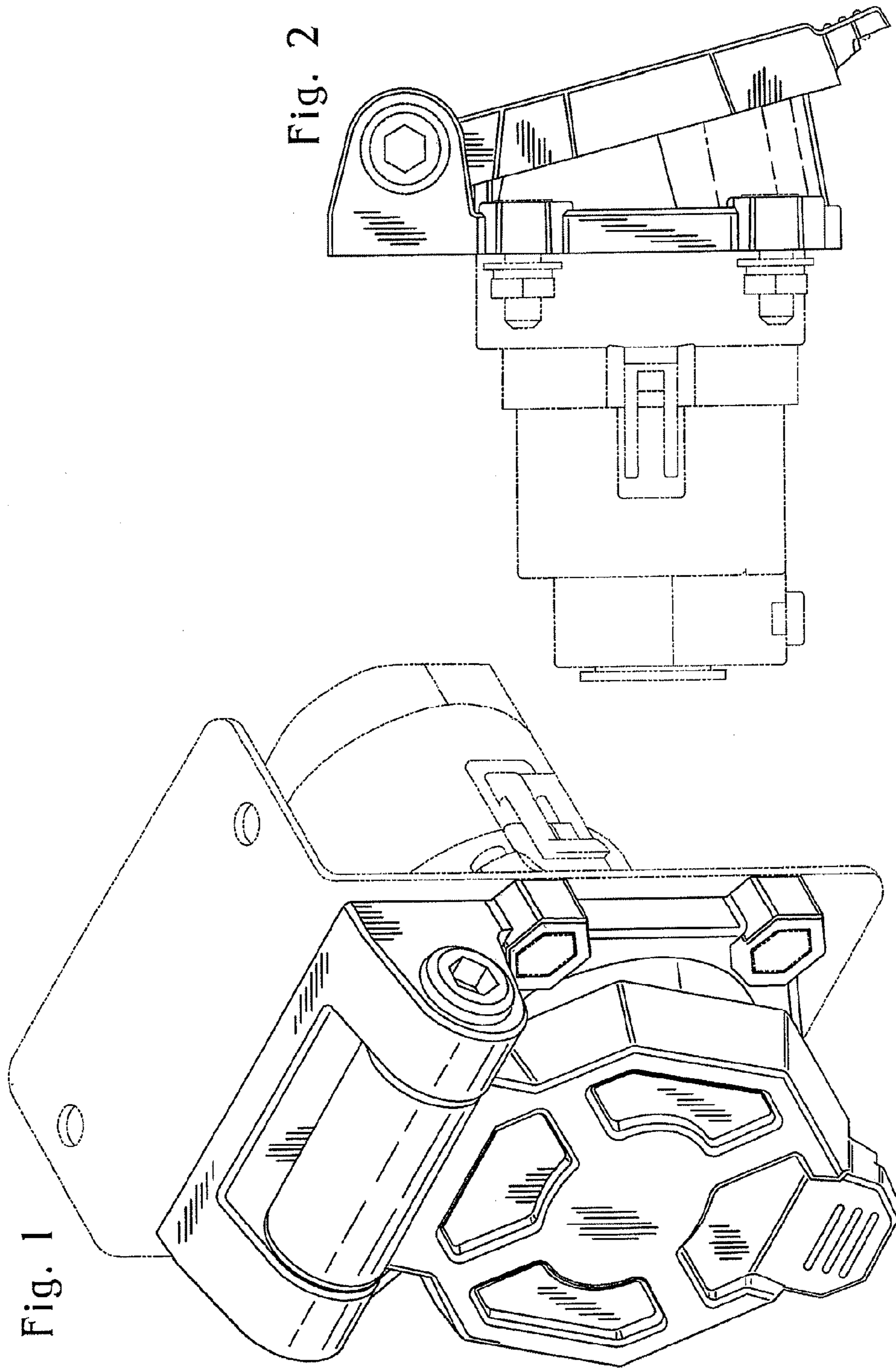

Fig. 4

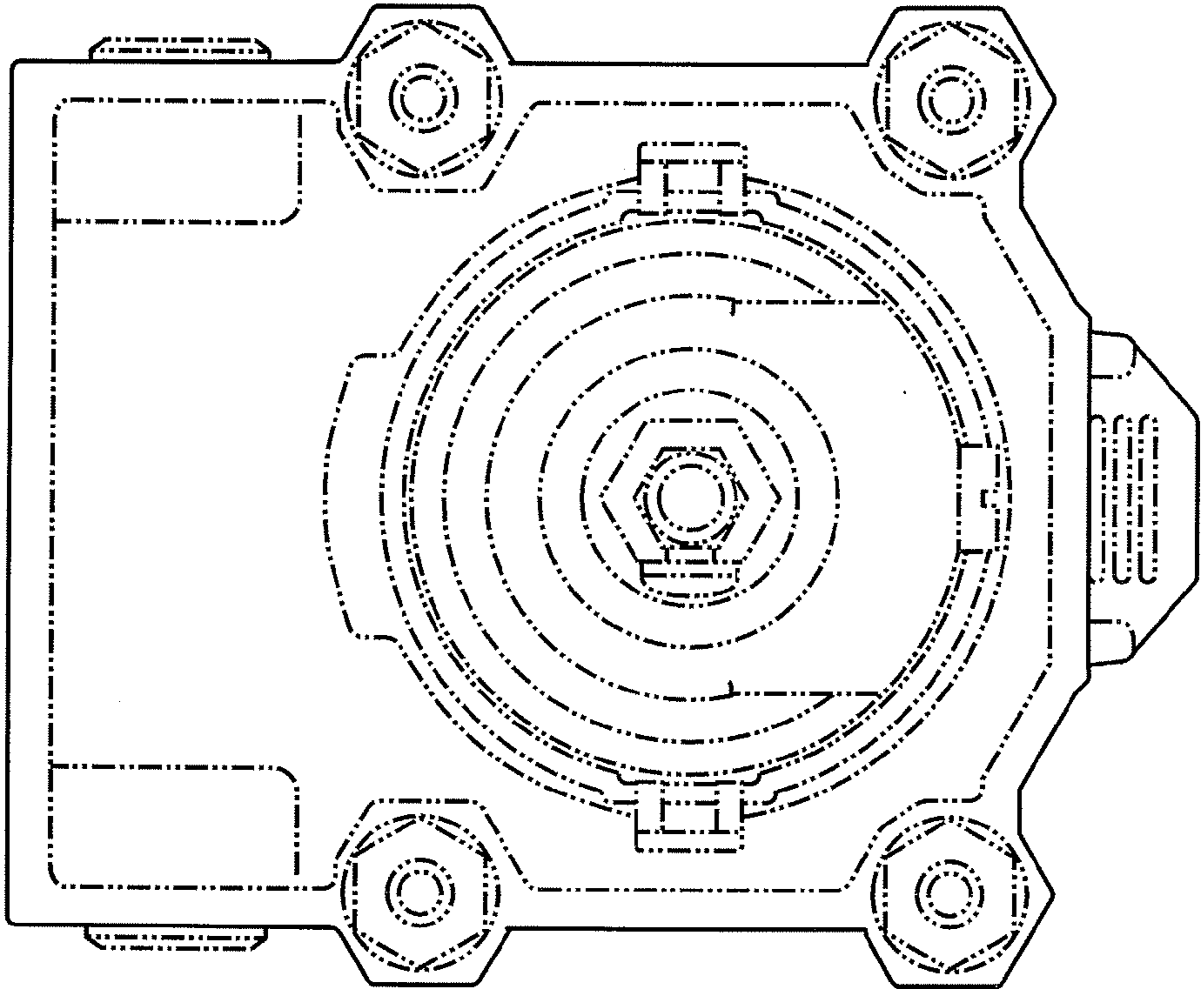

Fig. 3

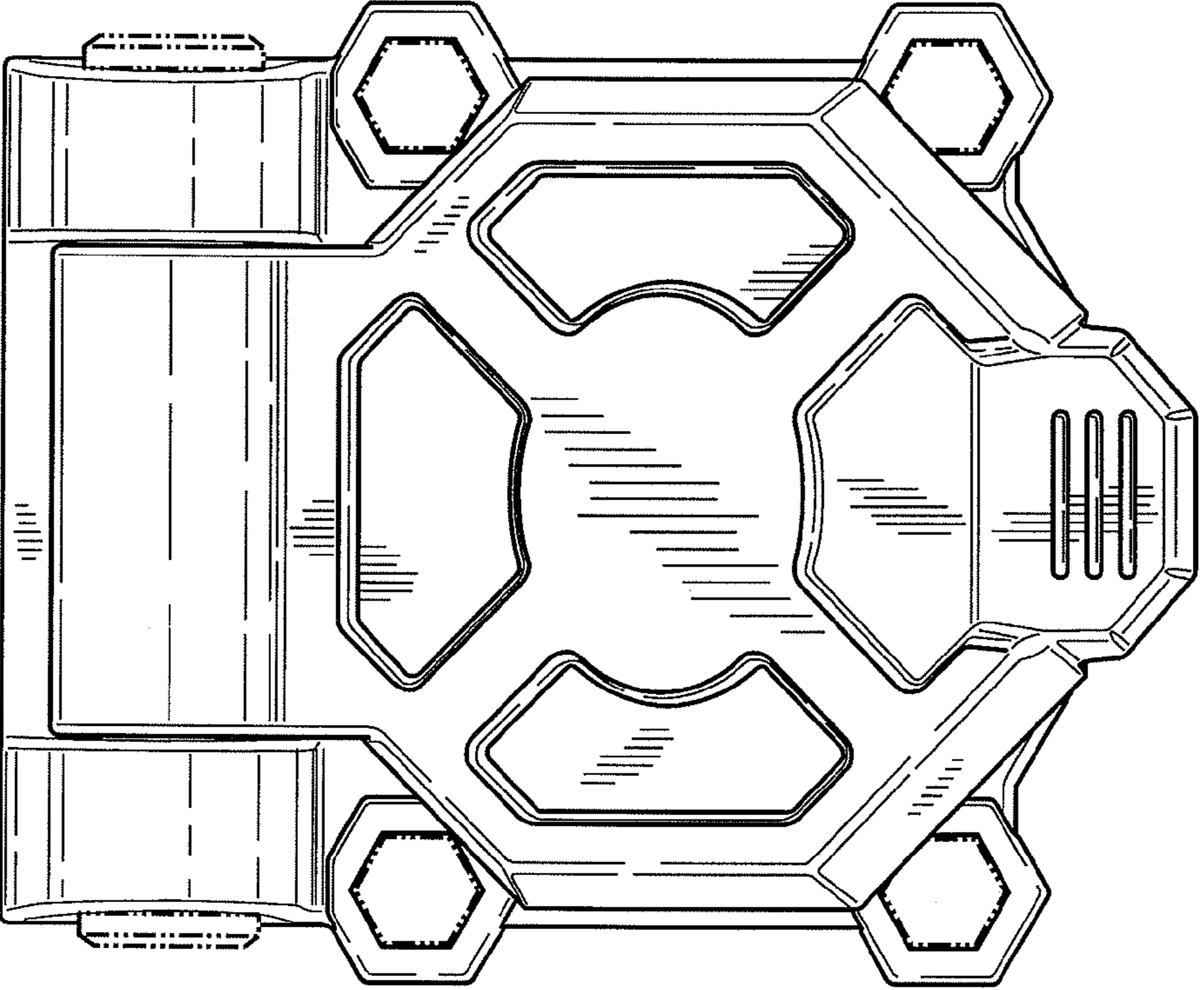

Fig. 5

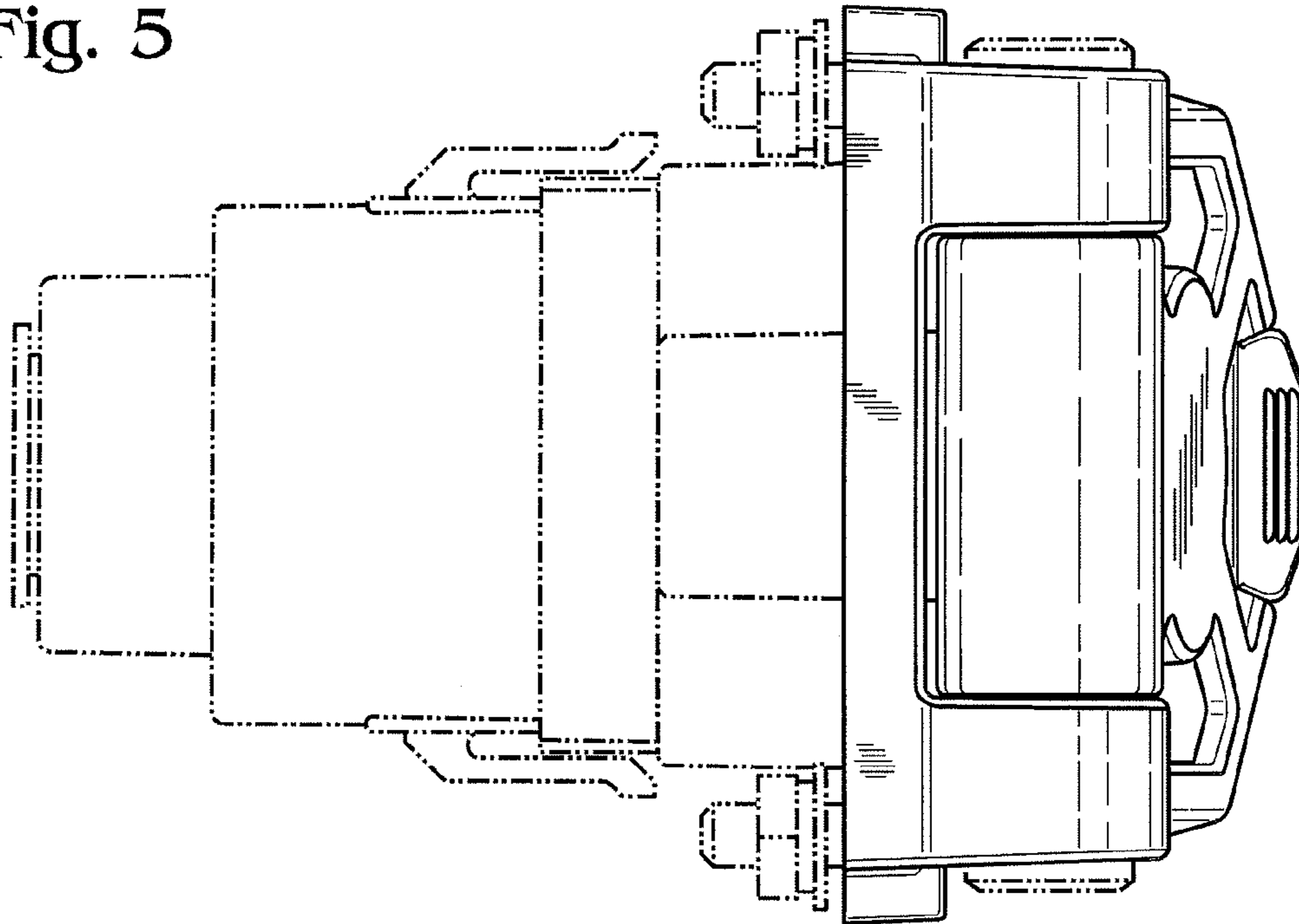

Fig. 6

