

US00D588504S

(12) **United States Design Patent**  
**Kawagishi**

(10) **Patent No.:** **US D588,504 S**  
(45) **Date of Patent:** **\*\* Mar. 17, 2009**

(54) **MOTORCYCLE**

(75) Inventor: **Masayuki Kawagishi**, Hamamatsu (JP)

(73) Assignee: **Suzuki Motor Corporation**,  
Hamamatsu-shi, Shizuoka-Prefecture  
(JP)

(\*\*) Term: **14 Years**

(21) Appl. No.: **29/284,632**

(22) Filed: **Sep. 12, 2007**

(51) **LOC (9) Cl.** ..... **12-11**

(52) **U.S. Cl.** ..... **D12/110**

(58) **Field of Classification Search** ..... D12/110;  
180/219

See application file for complete search history.

(56) **References Cited**

**U.S. PATENT DOCUMENTS**

D394,027 S *	5/1998	Ban et al.	.....	D12/110
D395,621 S *	6/1998	Nishino	.....	D12/110
D439,868 S *	4/2001	Sugimoto	.....	D12/110
D440,189 S *	4/2001	Ban et al.	.....	D12/110
D470,799 S *	2/2003	Yamaguchi et al.	.....	D12/110
D525,919 S *	8/2006	Sugimoto	.....	D12/110

\* cited by examiner

*Primary Examiner*—Cathron C Brooks

*Assistant Examiner*—Linda Brooks

(74) *Attorney, Agent, or Firm*—Dana M. Gordon; Foley Hoag LLP

(57) **CLAIM**

The ornamental design for a motorcycle, as shown and described.

**DESCRIPTION**

FIG. 1 is a front view of a motorcycle showing my new design;

FIG. 2 is a front perspective view of the left side thereof;

FIG. 3 is a left side elevational view thereof;

FIG. 4 is a rear perspective view of the left side thereof;

FIG. 5 is a rear elevational view thereof;

FIG. 6 is a rear perspective view of the right side thereof;

FIG. 7 is a right side elevational view thereof;

FIG. 8 is a front perspective view of the right side thereof; and,

FIG. 9 is a top view thereof.

The broken lines are for illustrative purposes only and form no part of the claimed design.

**1 Claim, 9 Drawing Sheets**

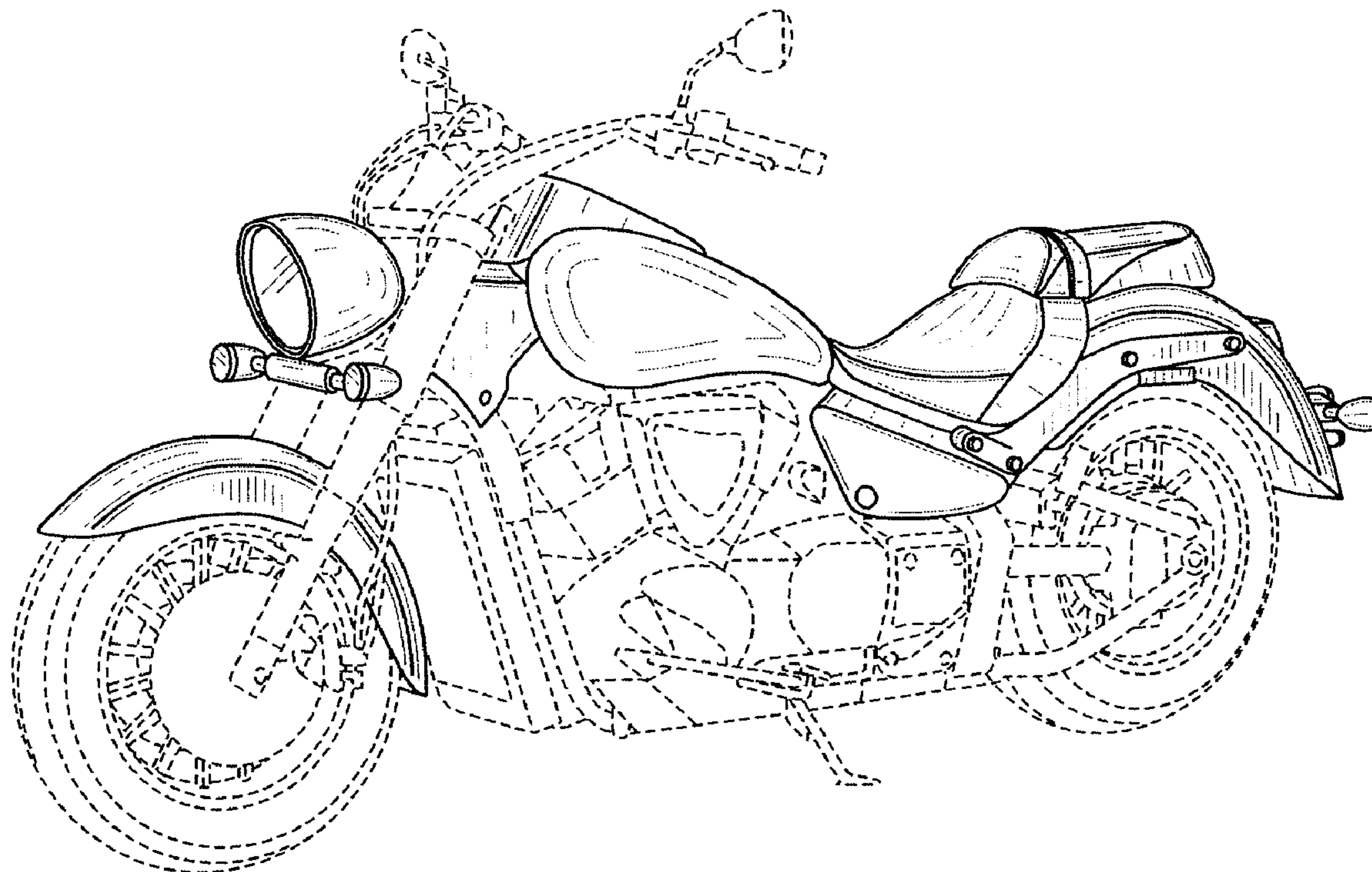

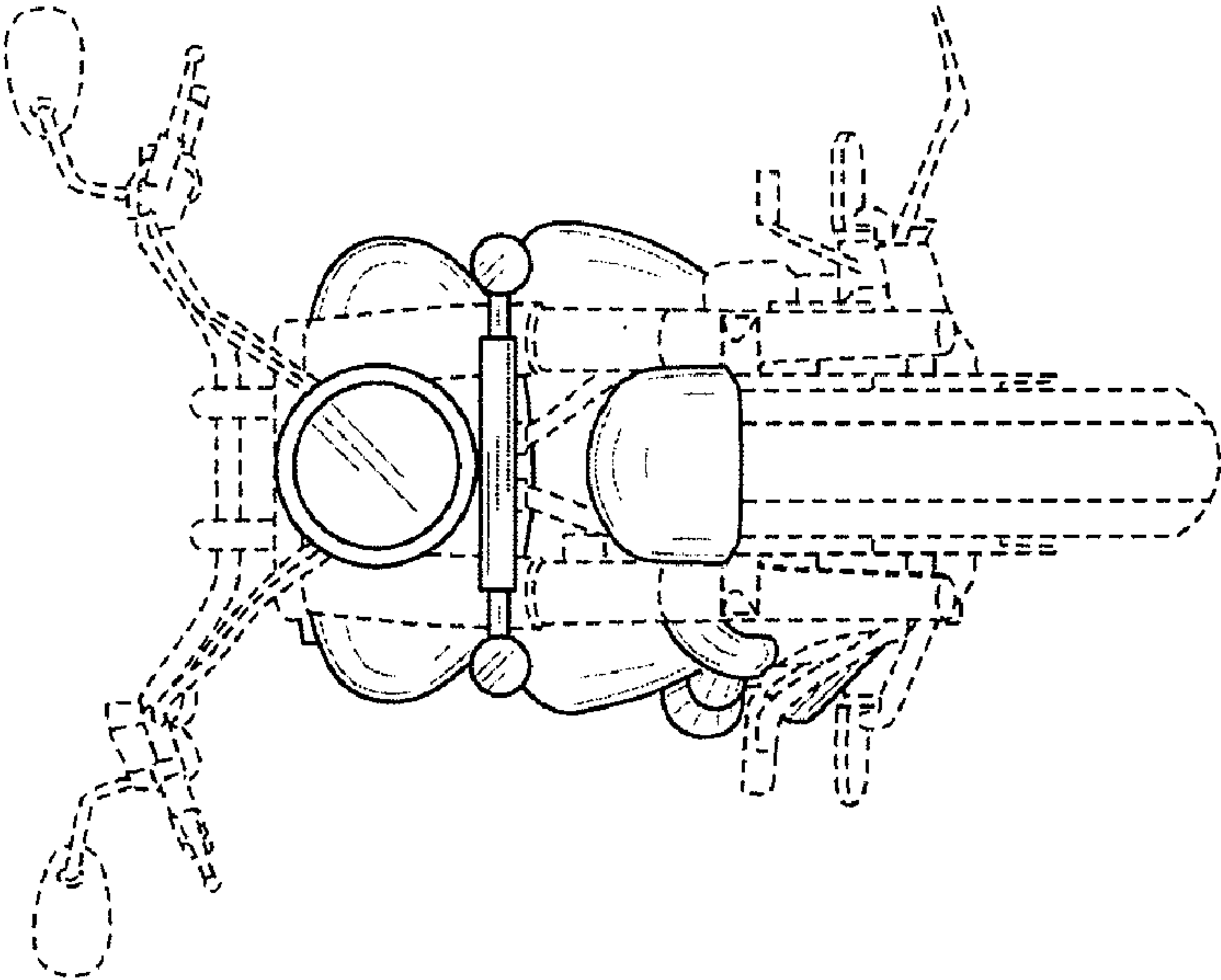

FIG. 1

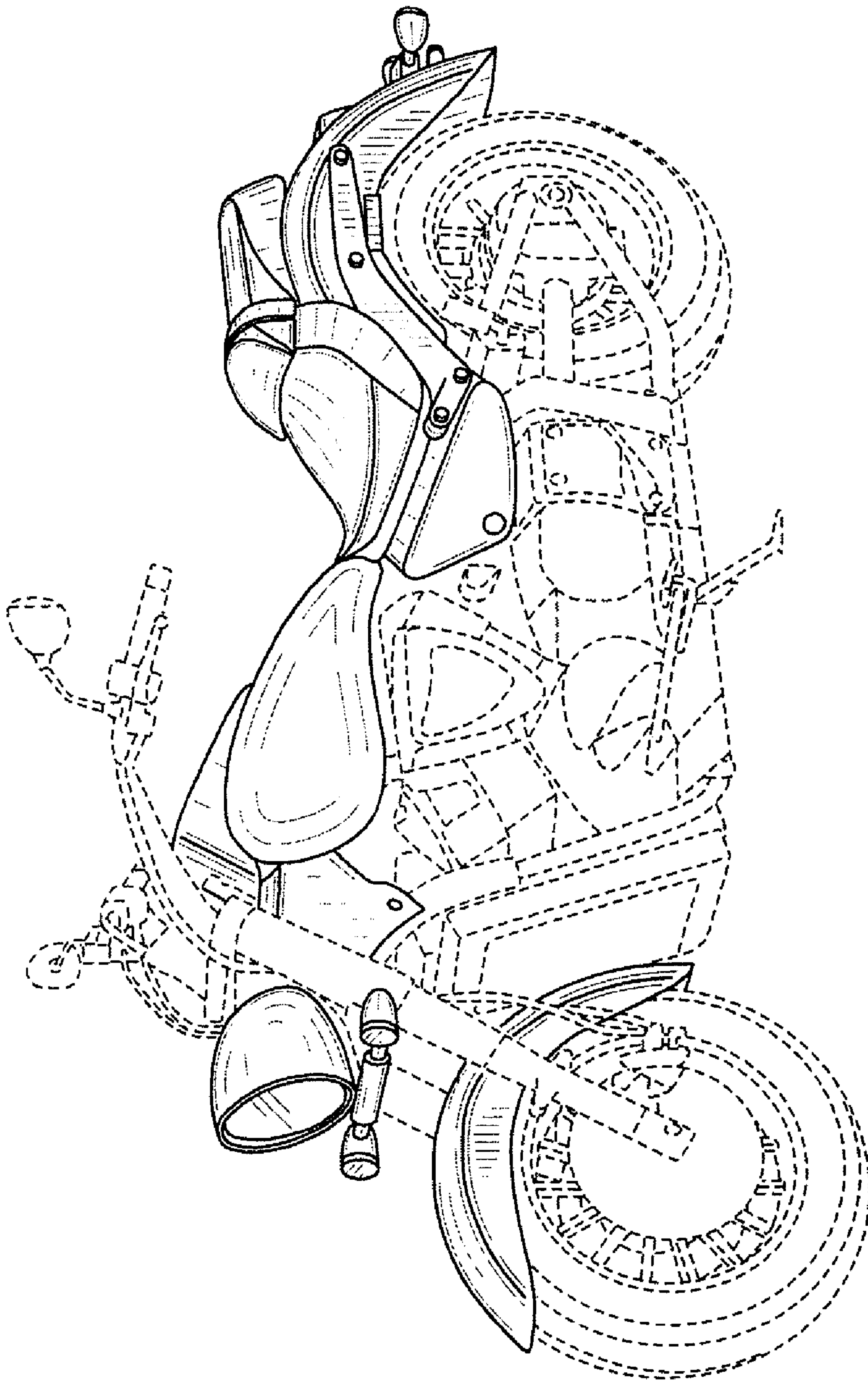

FIG. 2



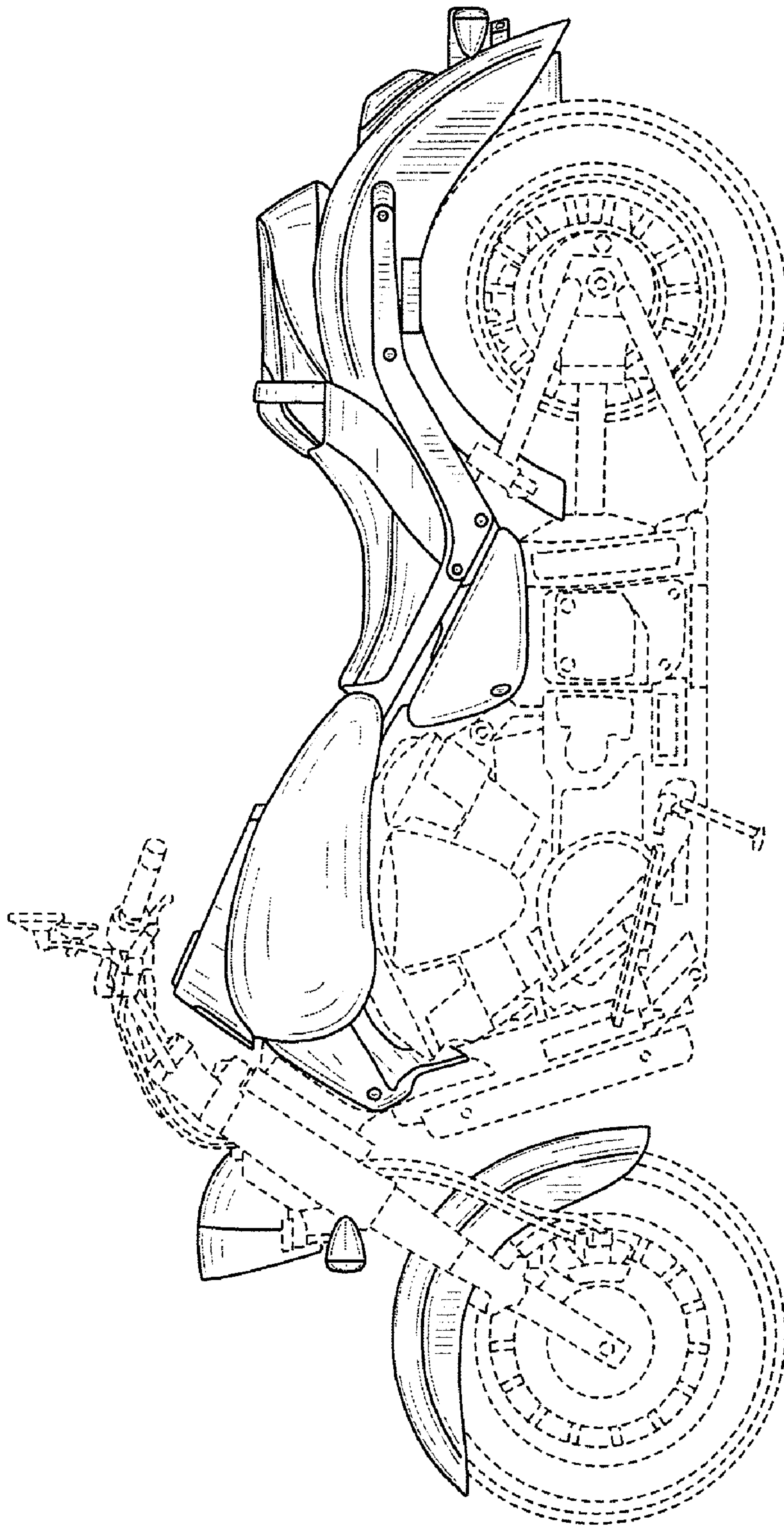

FIG. 3

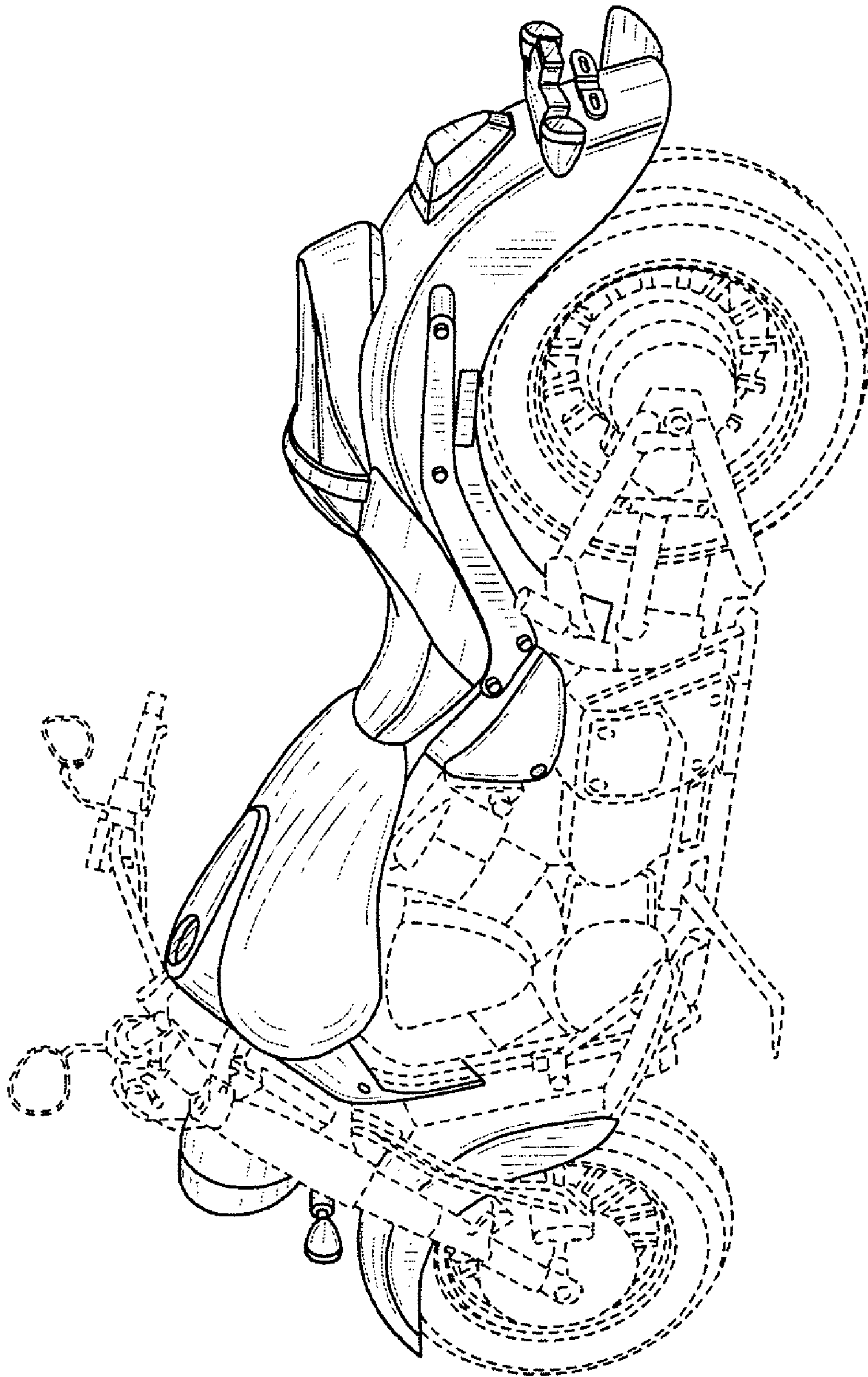

FIG. 4

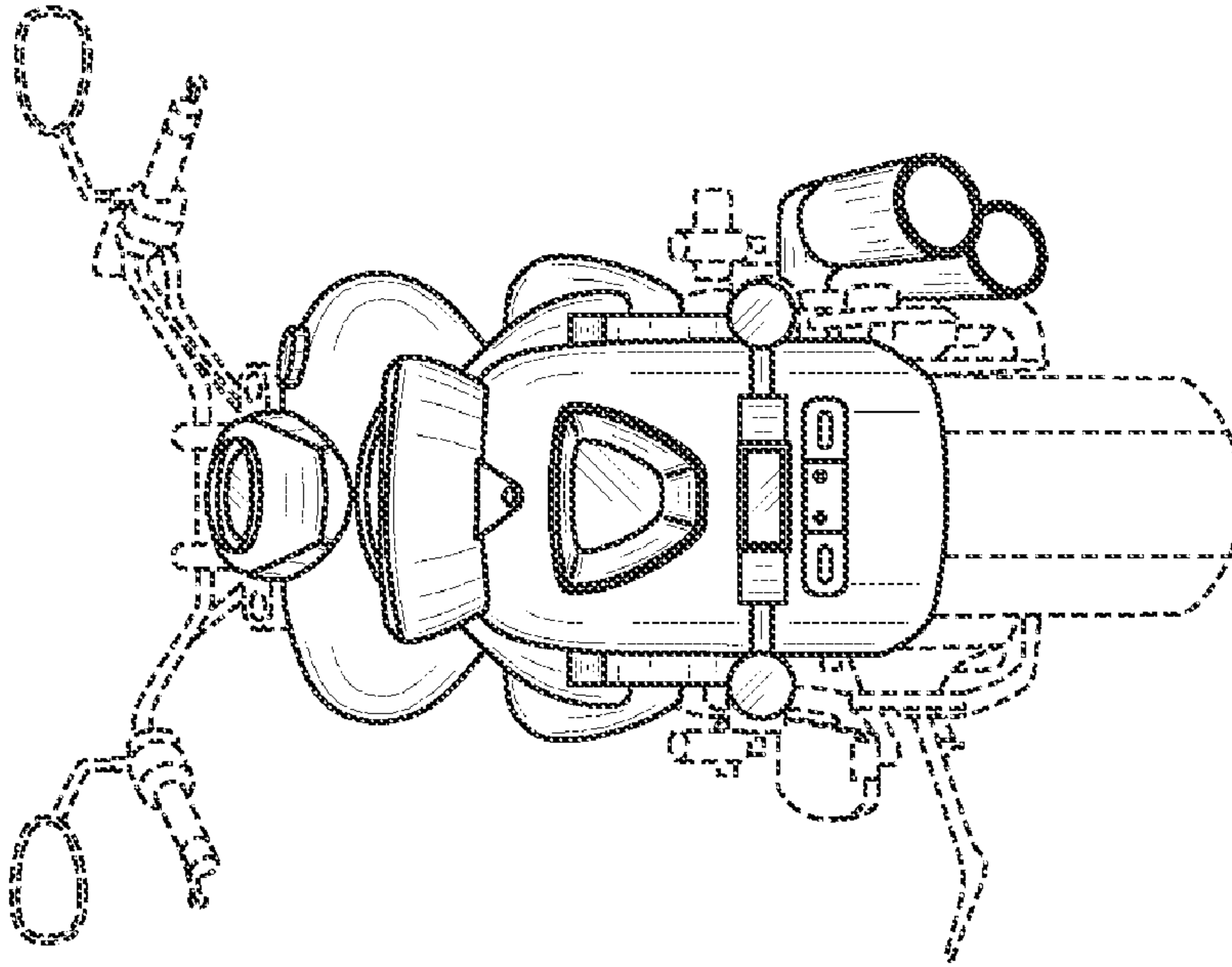

FIG. 5

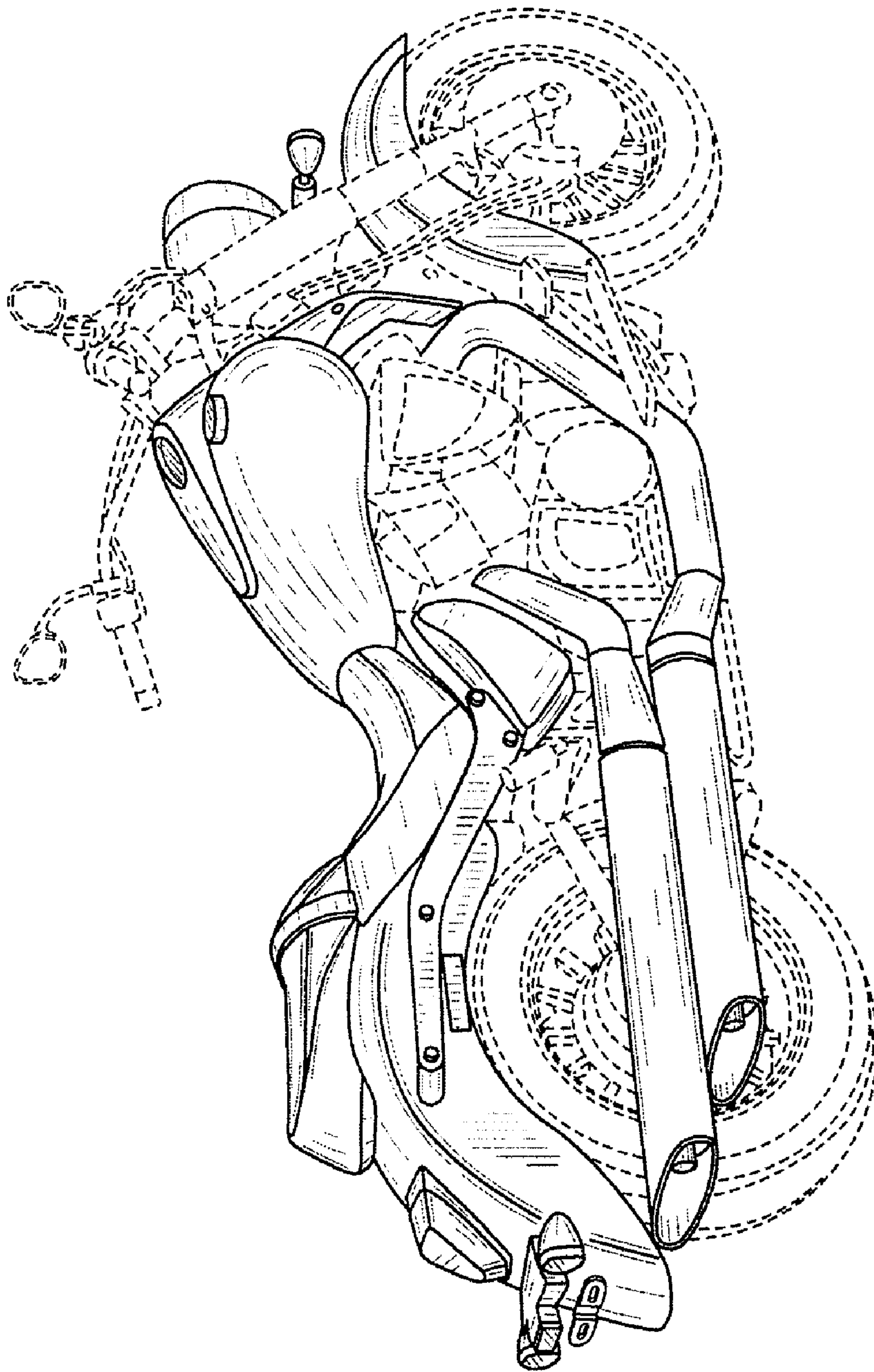

FIG. 6



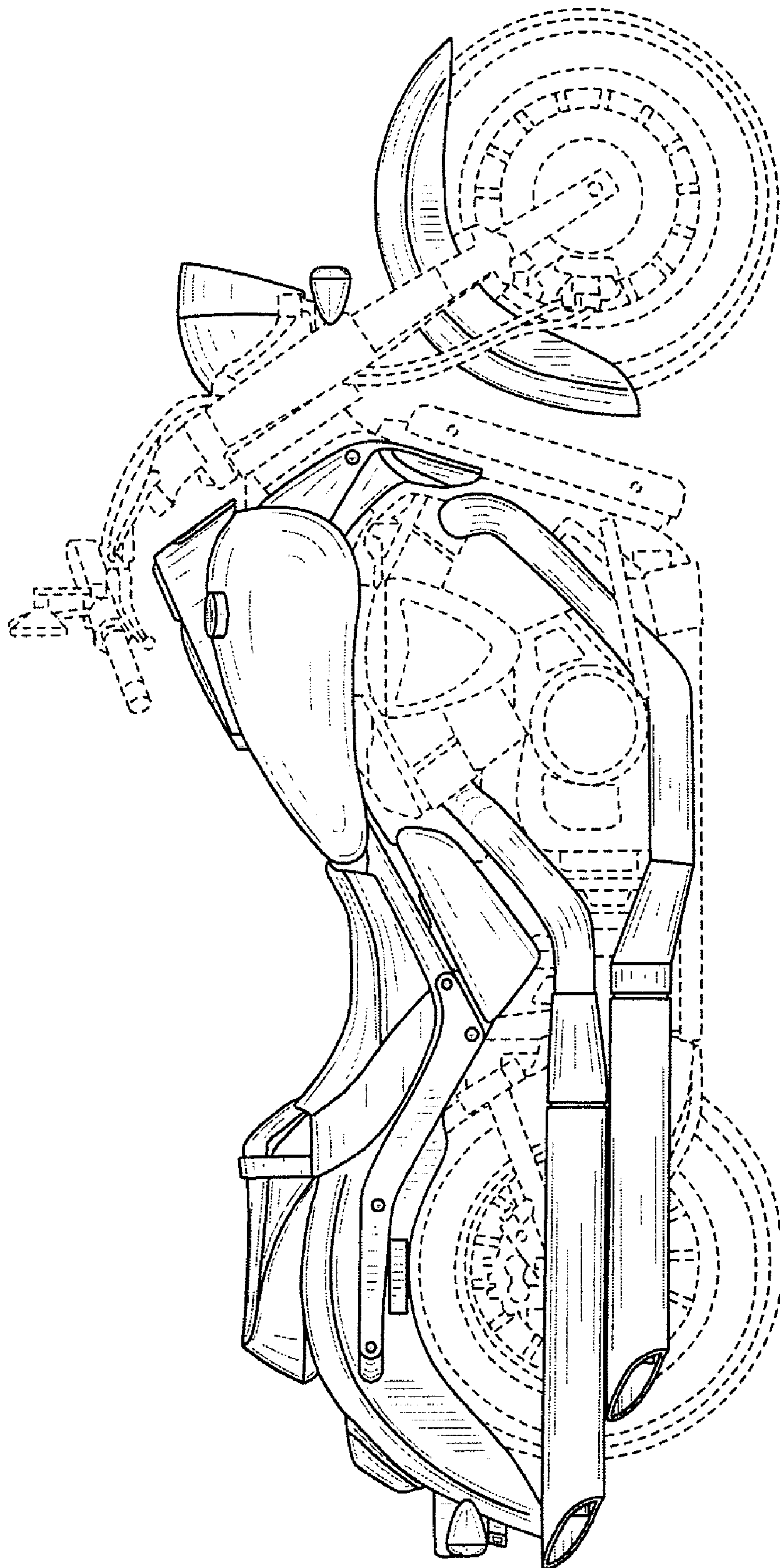

FIG. 7



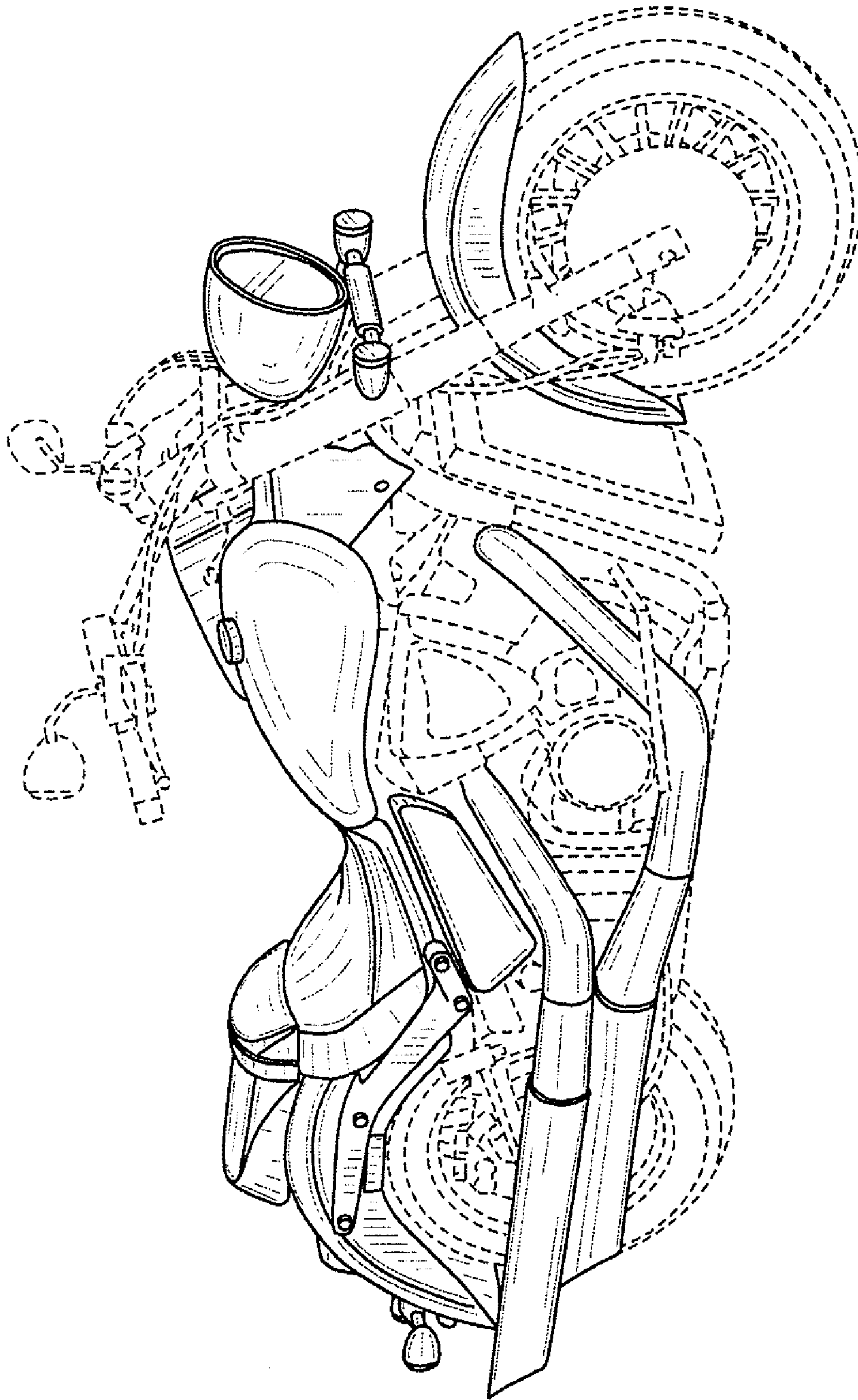

FIG. 8

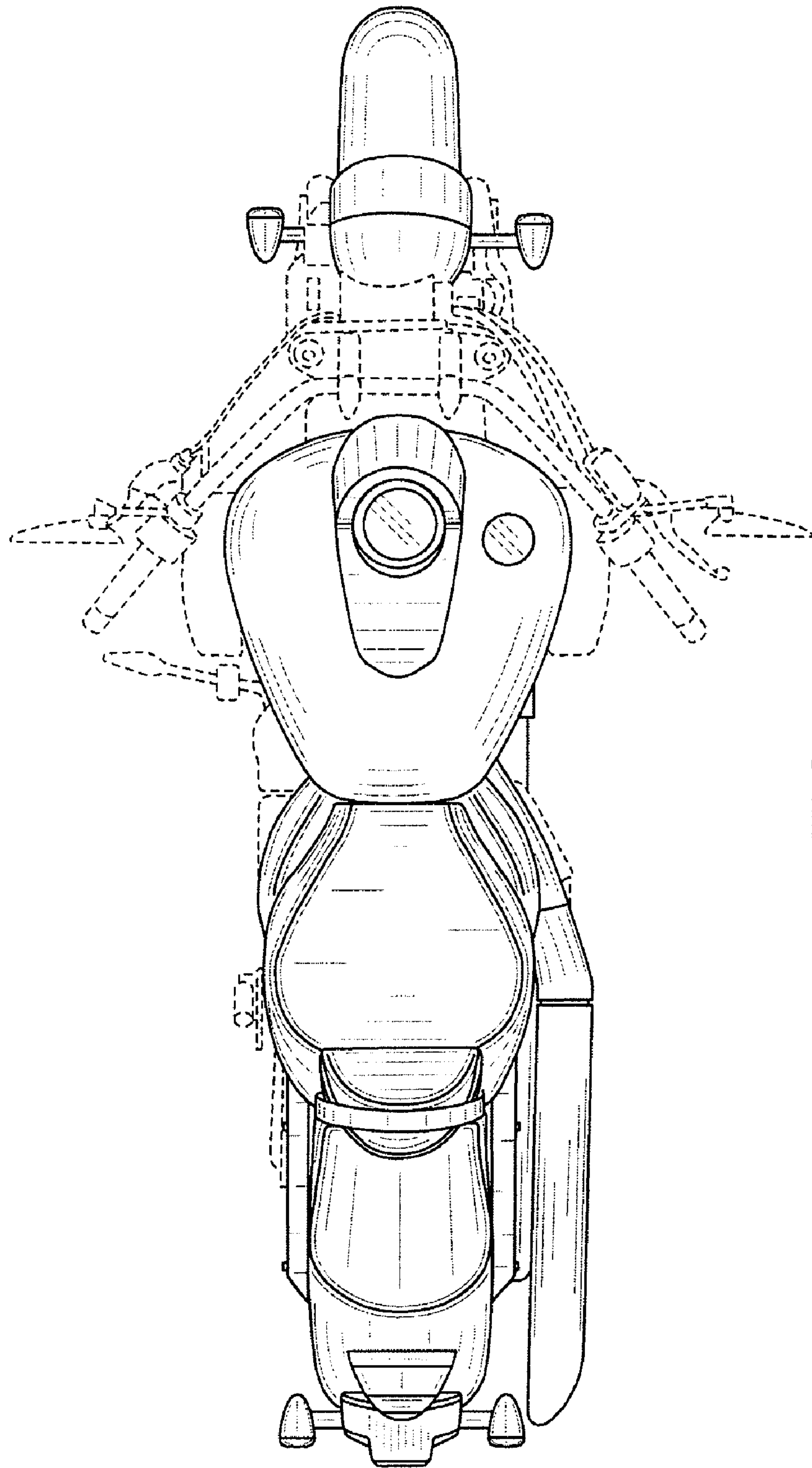

FIG. 9