



US00D588501S

(12) **United States Design Patent**
Kruger et al.

(10) **Patent No.:** **US D588,501 S**

(45) **Date of Patent:** **** Mar. 17, 2009**

(54) **AUTOMOBILE BODY**

D564,946 S * 3/2008 Kruger et al. D12/98

(75) Inventors: **Scott Kruger**, Macomb, MI (US);
Robert A. Williams, Grand Blanc, MI
(US); **Mark T. Allen**, Oxford, MI (US)

* cited by examiner

Primary Examiner—Melody N Brown

(74) *Attorney, Agent, or Firm*—Ralph E. Smith

(73) Assignee: **Chrysler LLC**, Auburn Hills, MI (US)

(57) **CLAIM**

(**) Term: **14 Years**

The ornamental design for an automobile body, as shown and described.

(21) Appl. No.: **29/304,483**

(22) Filed: **Mar. 3, 2008**

DESCRIPTION

(51) **LOC (9) Cl.** **12-08**

FIG. 1 is a front perspective view of an automobile body showing our new design;

(52) **U.S. Cl.** **D12/98**

FIG. 2 is a side view thereof;

(58) **Field of Classification Search** D12/86,
D12/90-92, 98; 296/181.1, 181.3, 181.5

FIG. 3 is a front view thereof;

See application file for complete search history.

FIG. 4 is a rear view thereof;

(56) **References Cited**

FIG. 5 is a rear perspective view thereof; and

U.S. PATENT DOCUMENTS

FIG. 6 is a front perspective view showing a second embodiment of our new design;

D430,068 S *	8/2000	Castiglione et al.	D12/98
D455,372 S	4/2002	Myles et al.	
D466,451 S *	12/2002	Trostle et al.	D12/98
D503,659 S *	4/2005	Matsumoto et al.	D12/98
D508,440 S *	8/2005	Hall et al.	D12/98
D516,957 S *	3/2006	O'Connell et al.	D12/98
D536,644 S *	2/2007	Shimoguchi et al.	D12/98
D537,385 S *	2/2007	Shimoguchi et al.	D12/98
D543,489 S *	5/2007	Gunby	D12/98
D551,127 S *	9/2007	Kruger et al.	D12/98

FIG. 7 is a side view of FIG. 6;

FIG. 8 is a front view of FIG. 6; and,

FIG. 9 is a rear perspective view of FIG 6.

It will be understood that the broken lines presented in the drawings are for illustration only, and do not form a part of the claimed design.

1 Claim, 8 Drawing Sheets

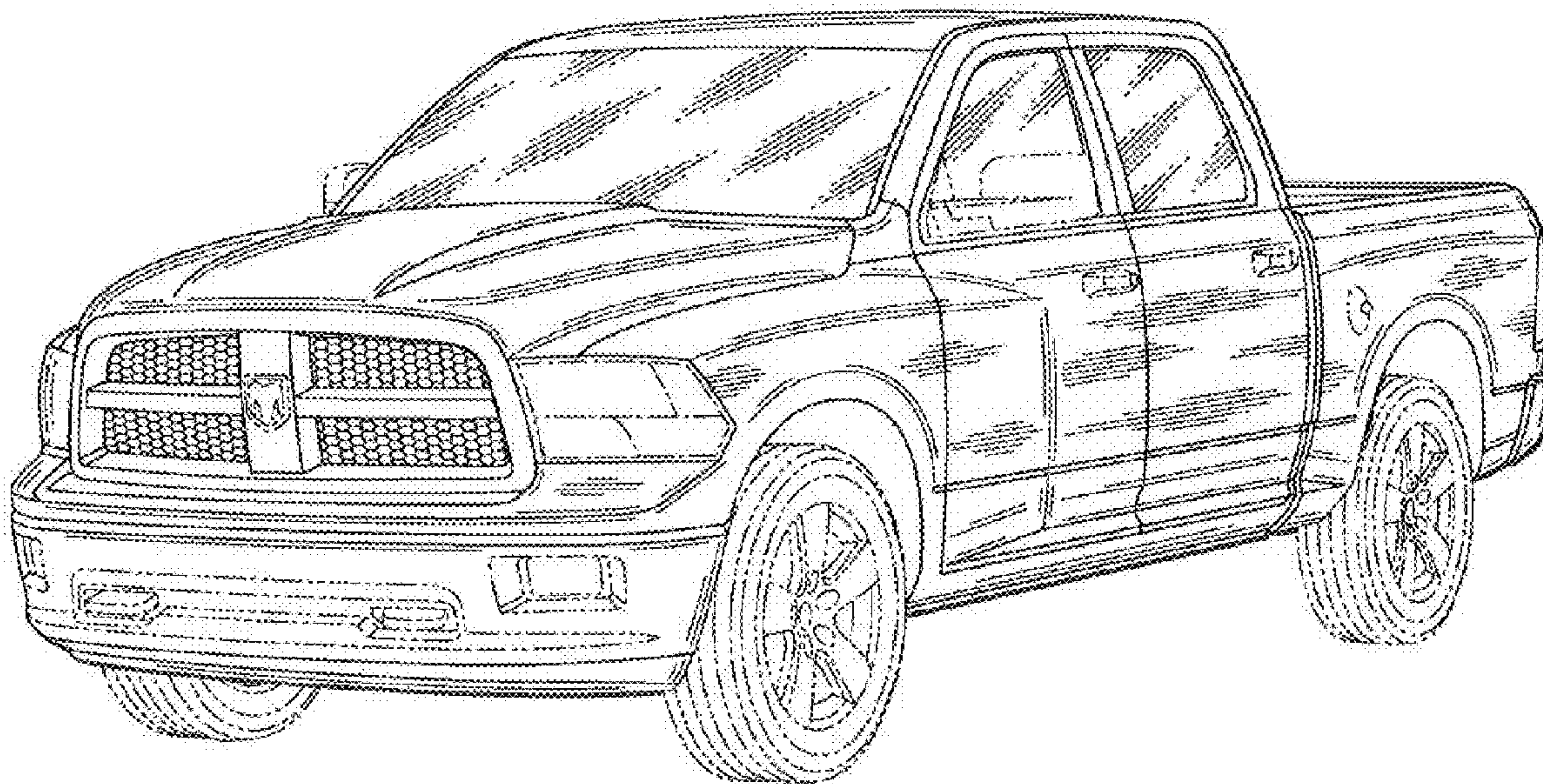

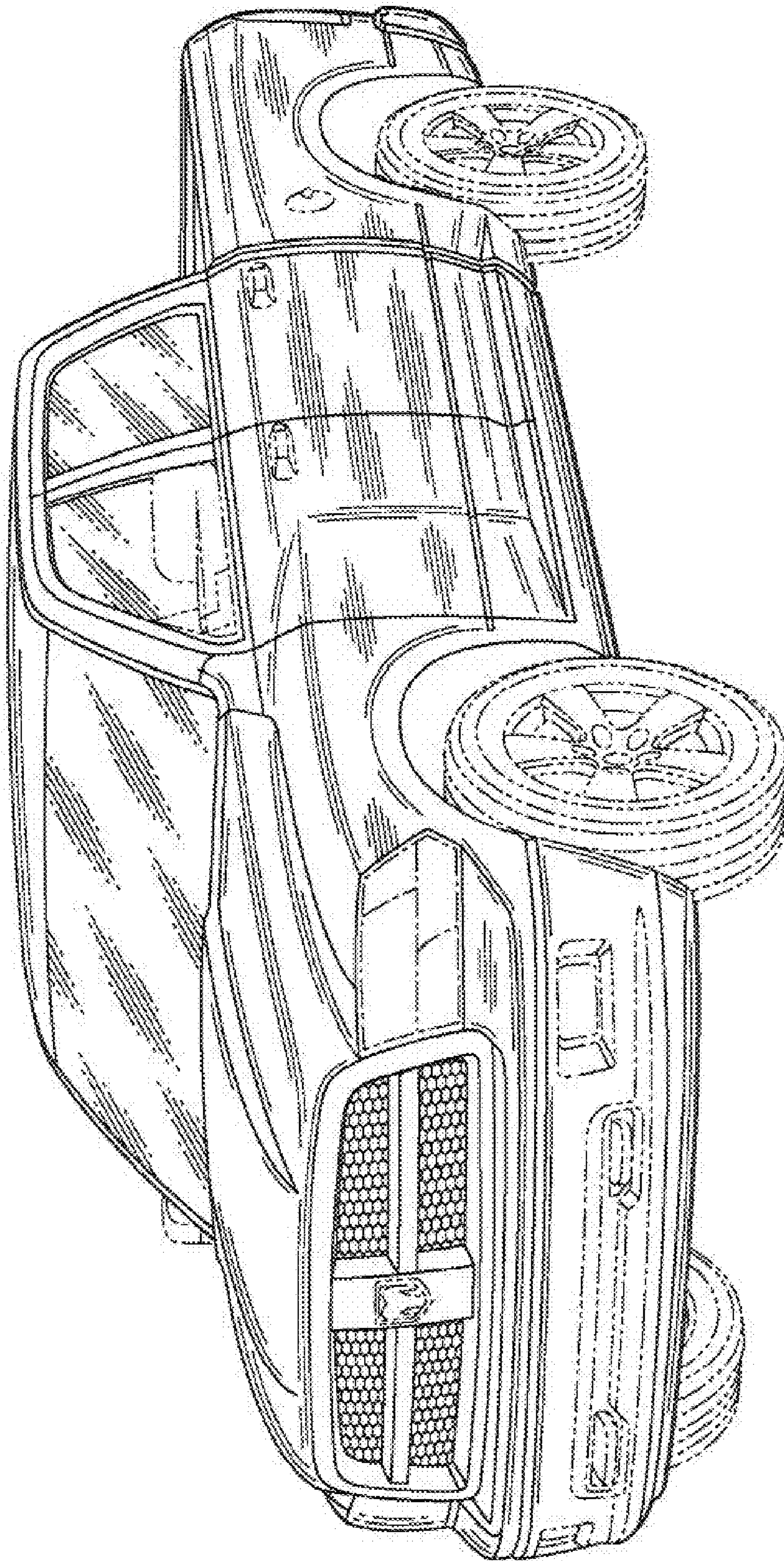

Fig. 1

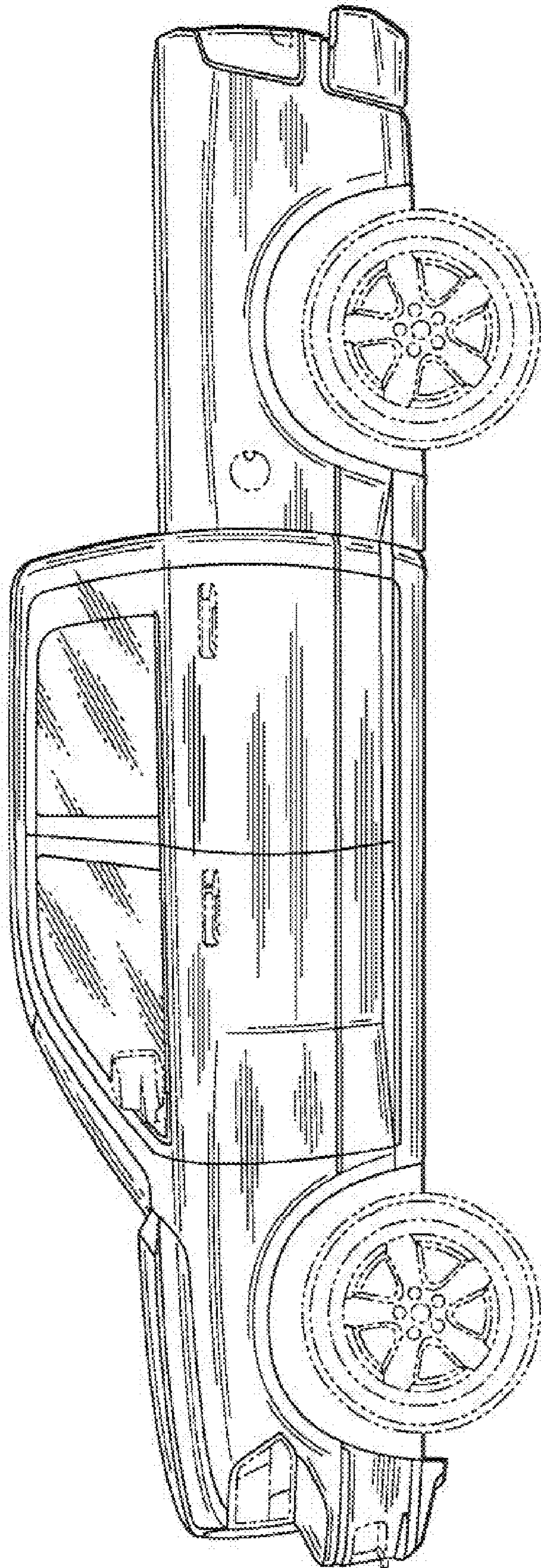

Fig. 2

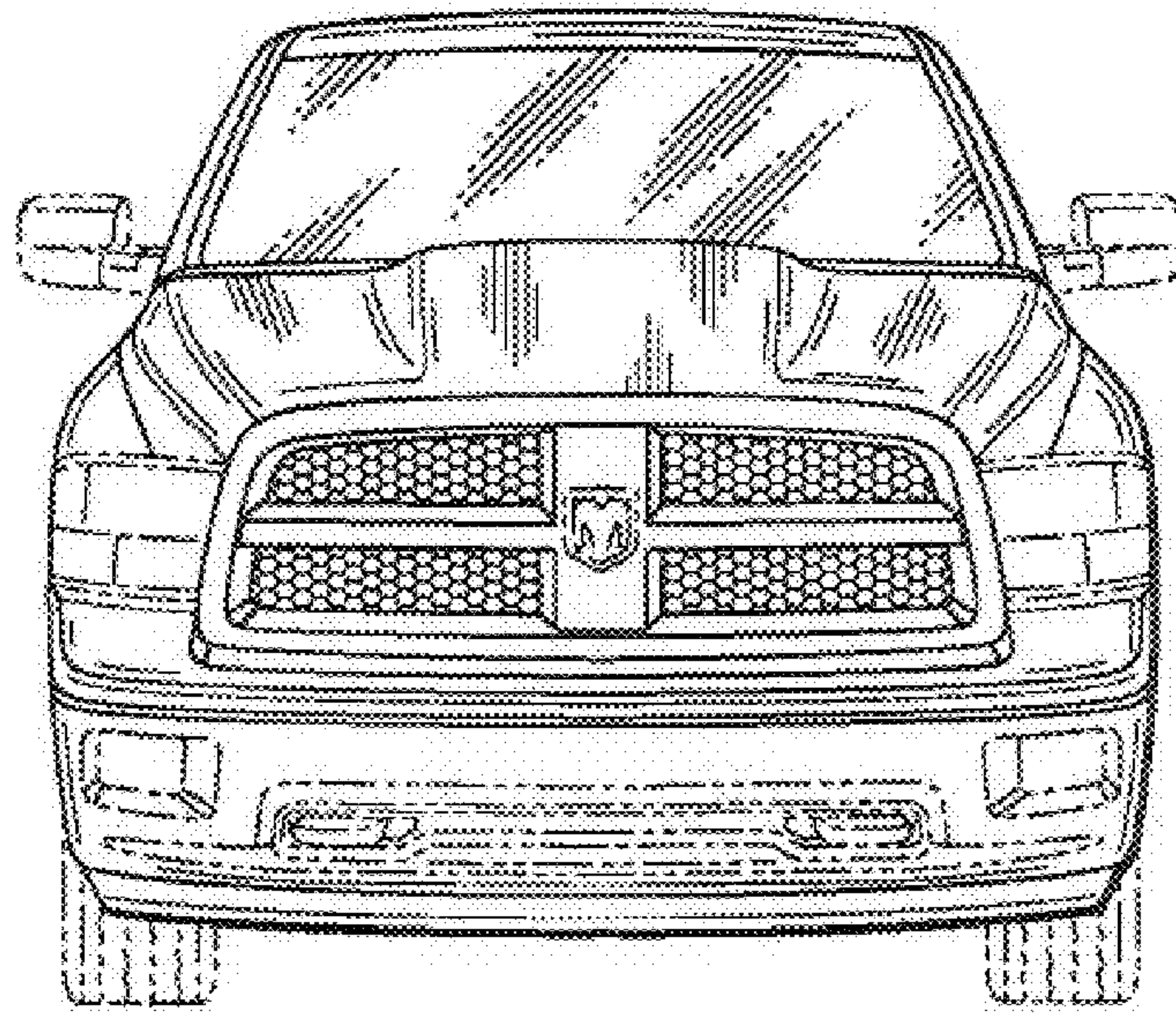

Fig. 3

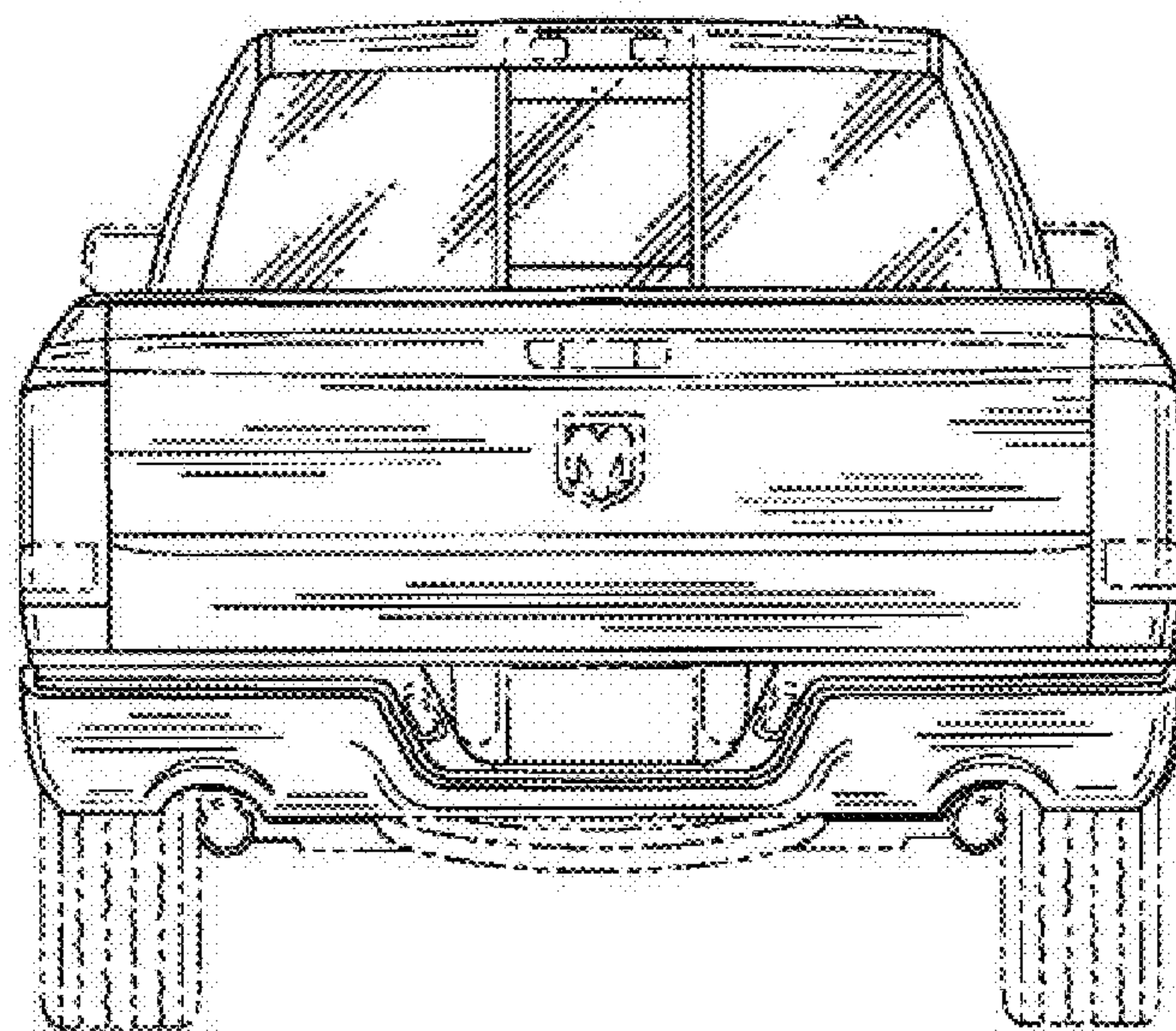

Fig. 4

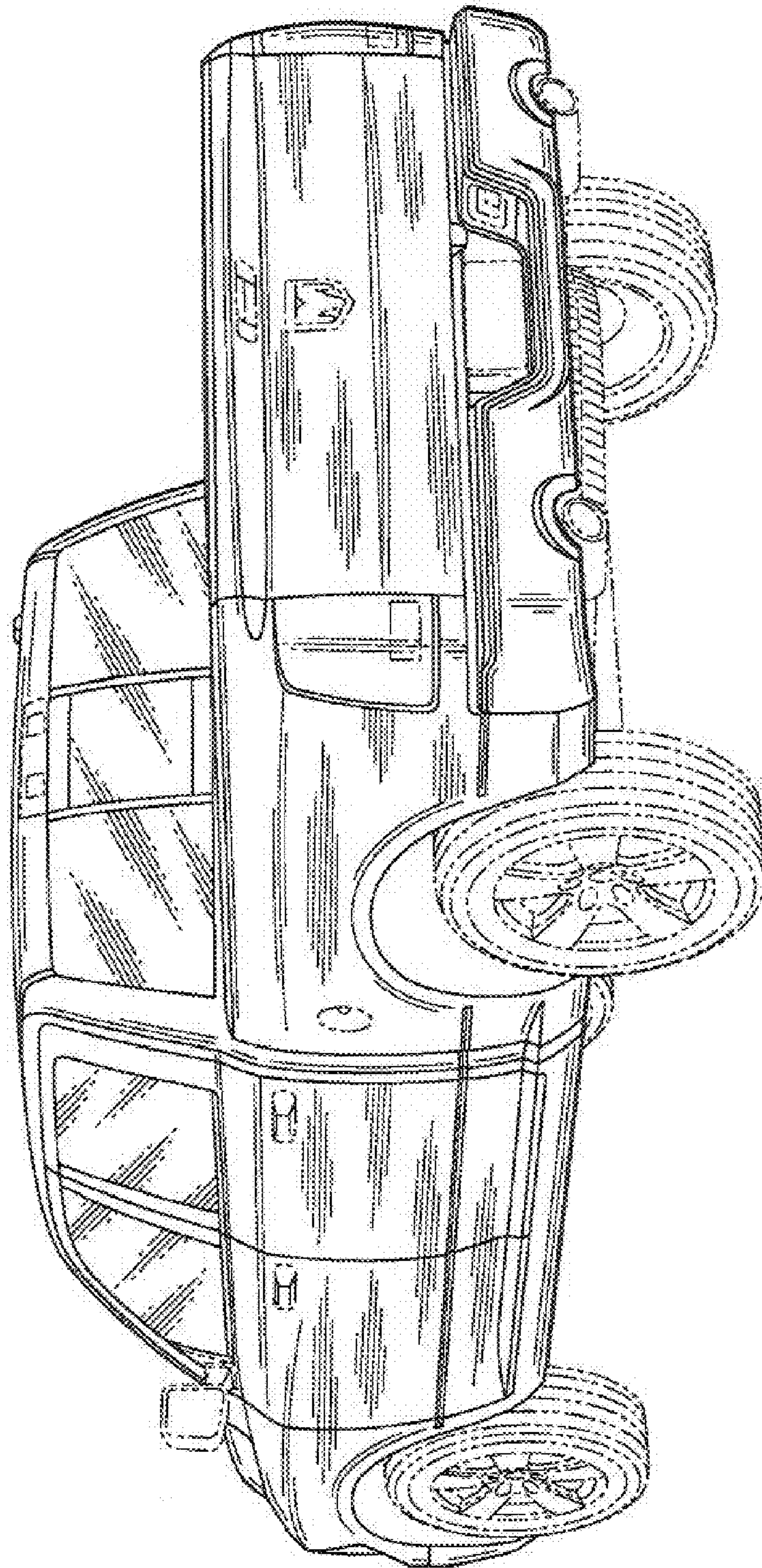

Fig. 5

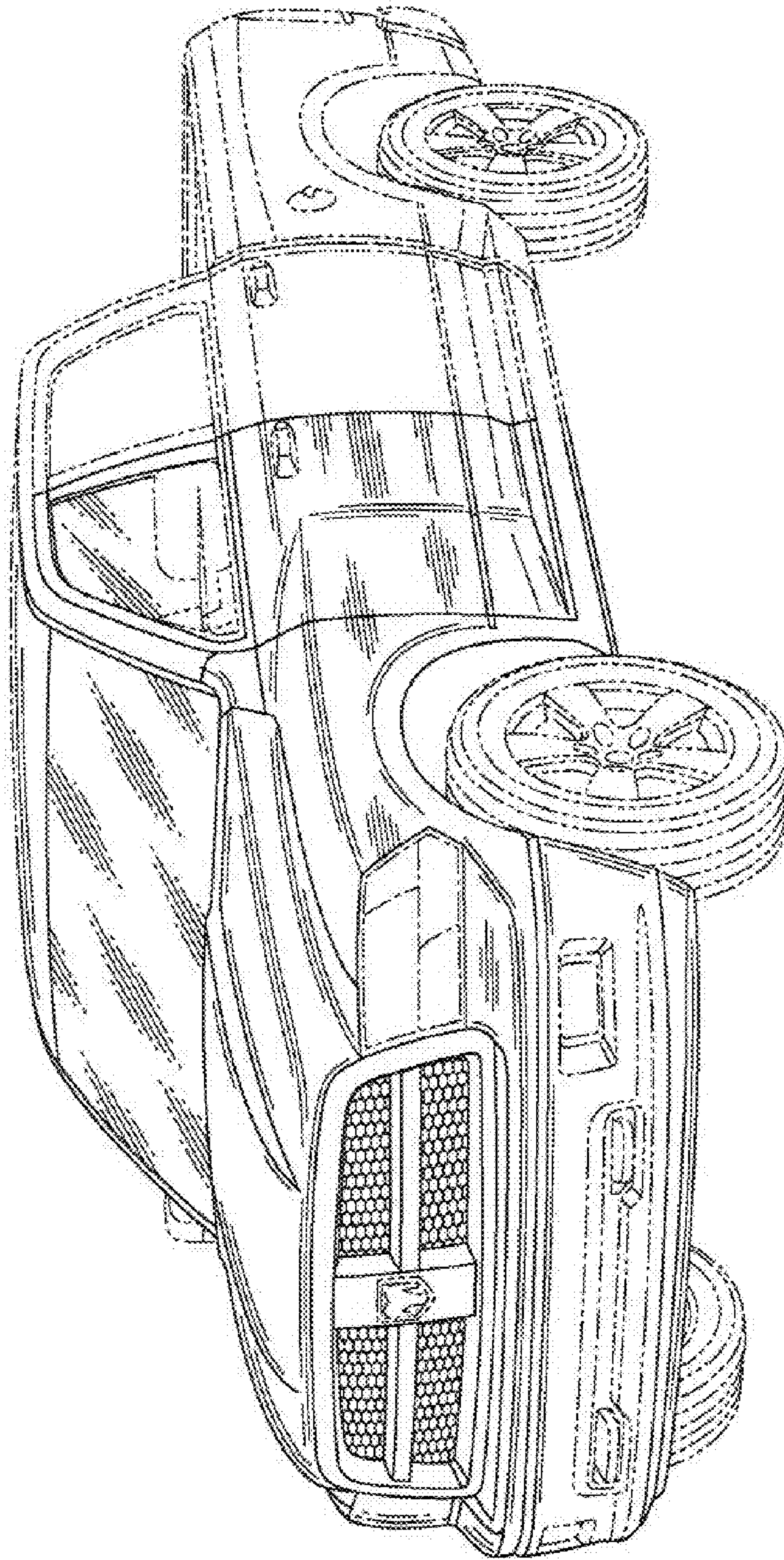

Fig. 6

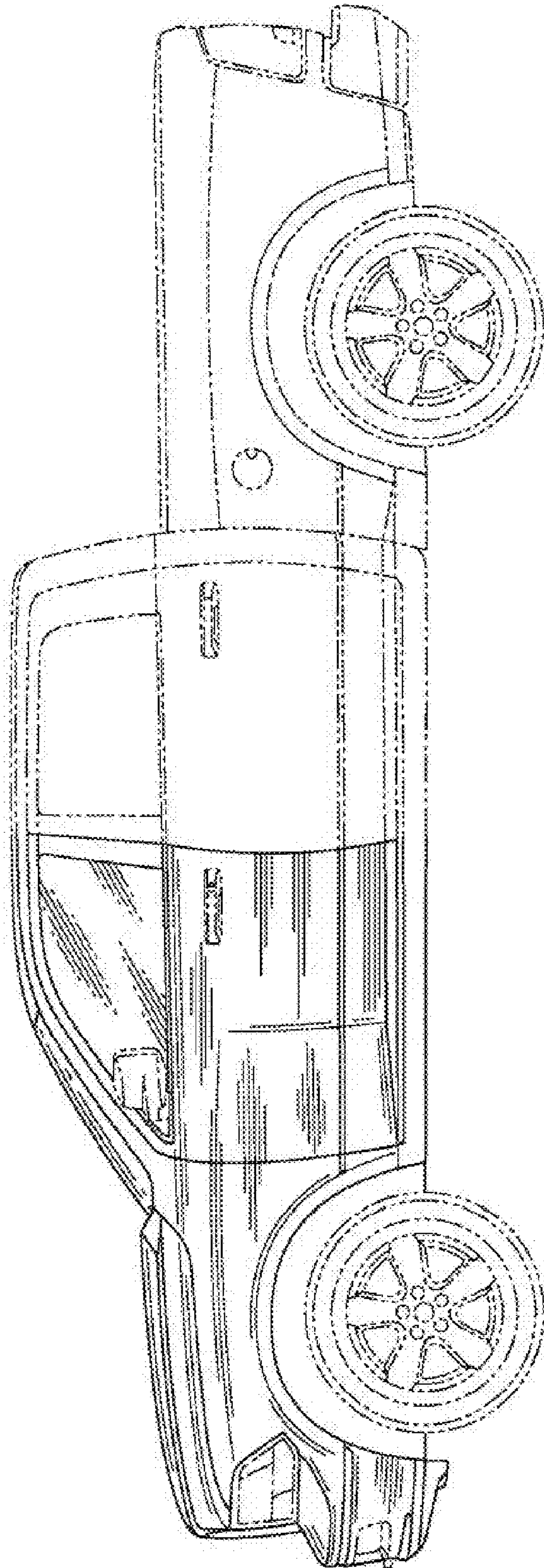

Fig. 7

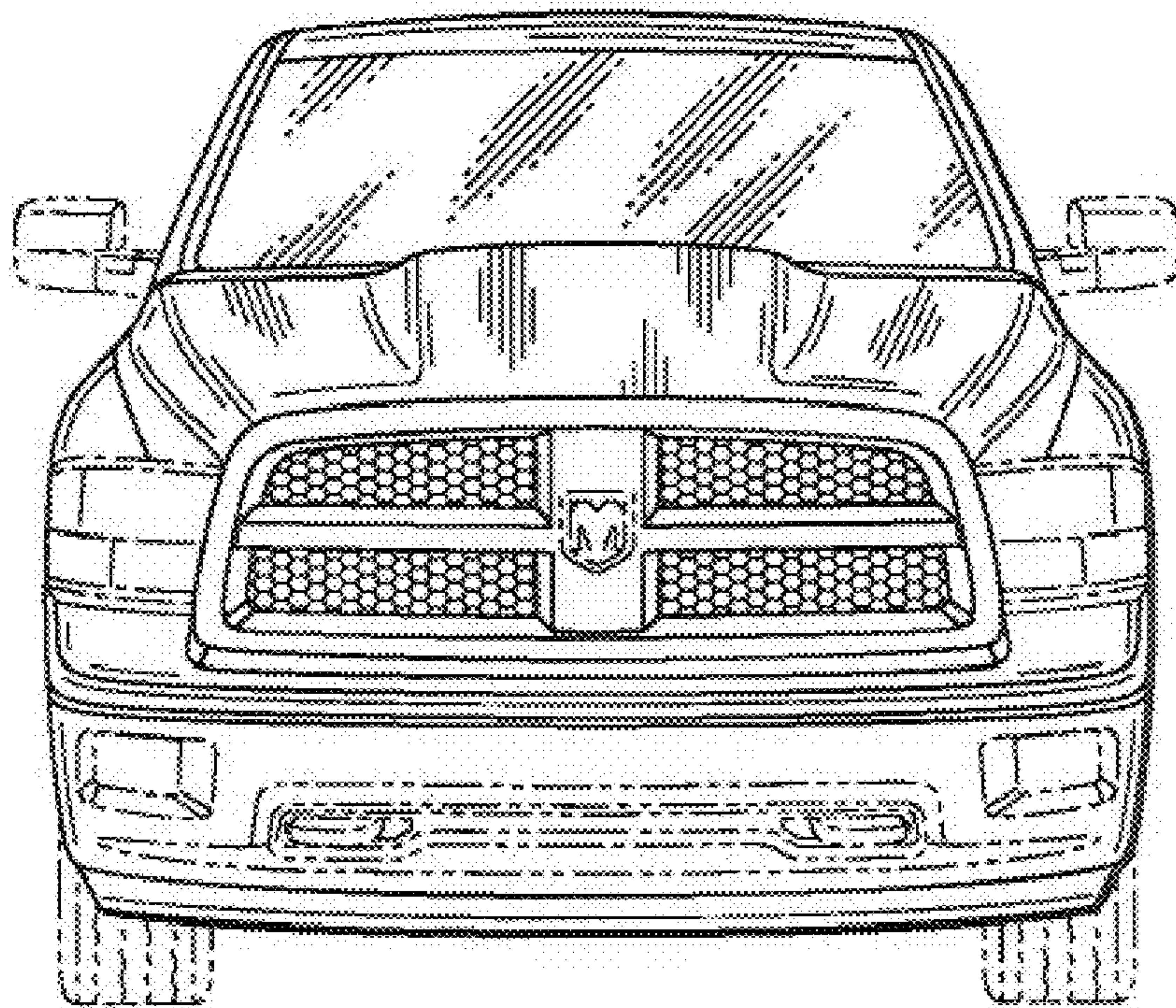

Fig. 8

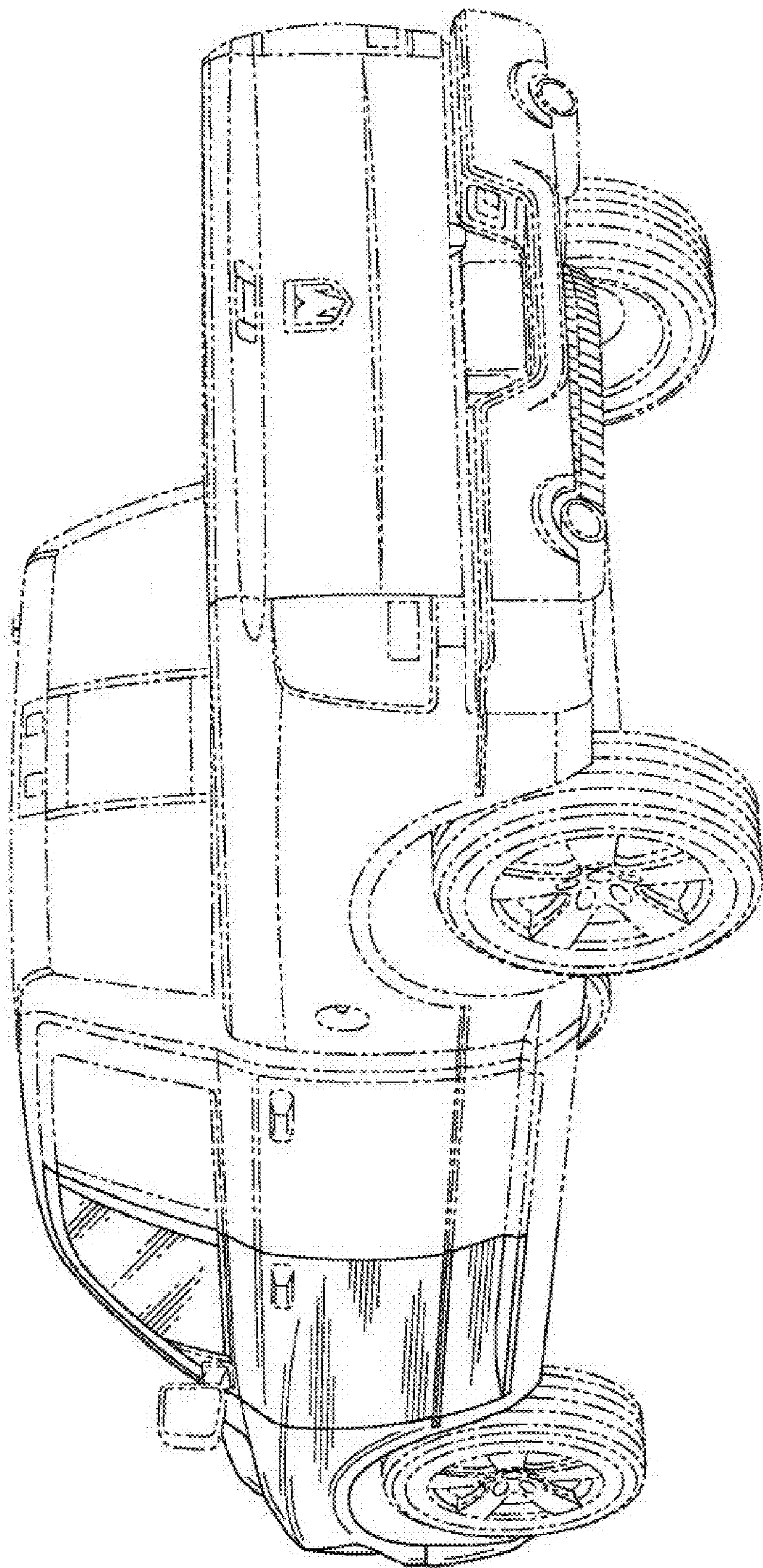

Fig. 9