



US00D588500S

(12) **United States Design Patent**  
**Howell et al.**

(10) **Patent No.:** **US D588,500 S**  
(45) **Date of Patent:** **\*\* Mar. 17, 2009**

(54) **AUTOMOBILE BODY**

D563,278 S \* 3/2008 Nakagawa et al. .... D12/92

(75) Inventors: **Greg Howell**, Farmington, MI (US);  
**Clifford Wilkins**, Rochester Hills, MI  
(US); **Lance R. Wagner**, Lake Orion,  
MI (US)

\* cited by examiner

*Primary Examiner*—Melody N Brown  
(74) *Attorney, Agent, or Firm*—Ralph E. Smith

(73) Assignee: **Chrysler LLC**, Auburn Hills, MI (US)

(57) **CLAIM**

(\*\*) Term: **14 Years**

The ornamental design for an automobile body, as shown and described.

(21) Appl. No.: **29/306,868**

**DESCRIPTION**

(22) Filed: **Apr. 17, 2008**

FIG. 1 is a front perspective view of an automobile body showing our new design;

(51) **LOC (9) Cl.** ..... **12-08**

FIG. 2 is a rear perspective view thereof;

(52) **U.S. Cl.** ..... **D12/92**

FIG. 3 is a side view thereof;

(58) **Field of Classification Search** ..... D12/86,  
D12/90-92; 296/181.1, 181.5

FIG. 4 is a front view thereof; and,

See application file for complete search history.

FIG. 5 is a rear view thereof.

(56) **References Cited**

It will be understood that the broken lines presented in the drawings are for illustration only, and do not form a part of the claimed design.

**U.S. PATENT DOCUMENTS**

D430,064 S \* 8/2000 Verduyn et al. .... D12/92  
D528,472 S \* 9/2006 Yamada et al. .... D12/91

**1 Claim, 5 Drawing Sheets**

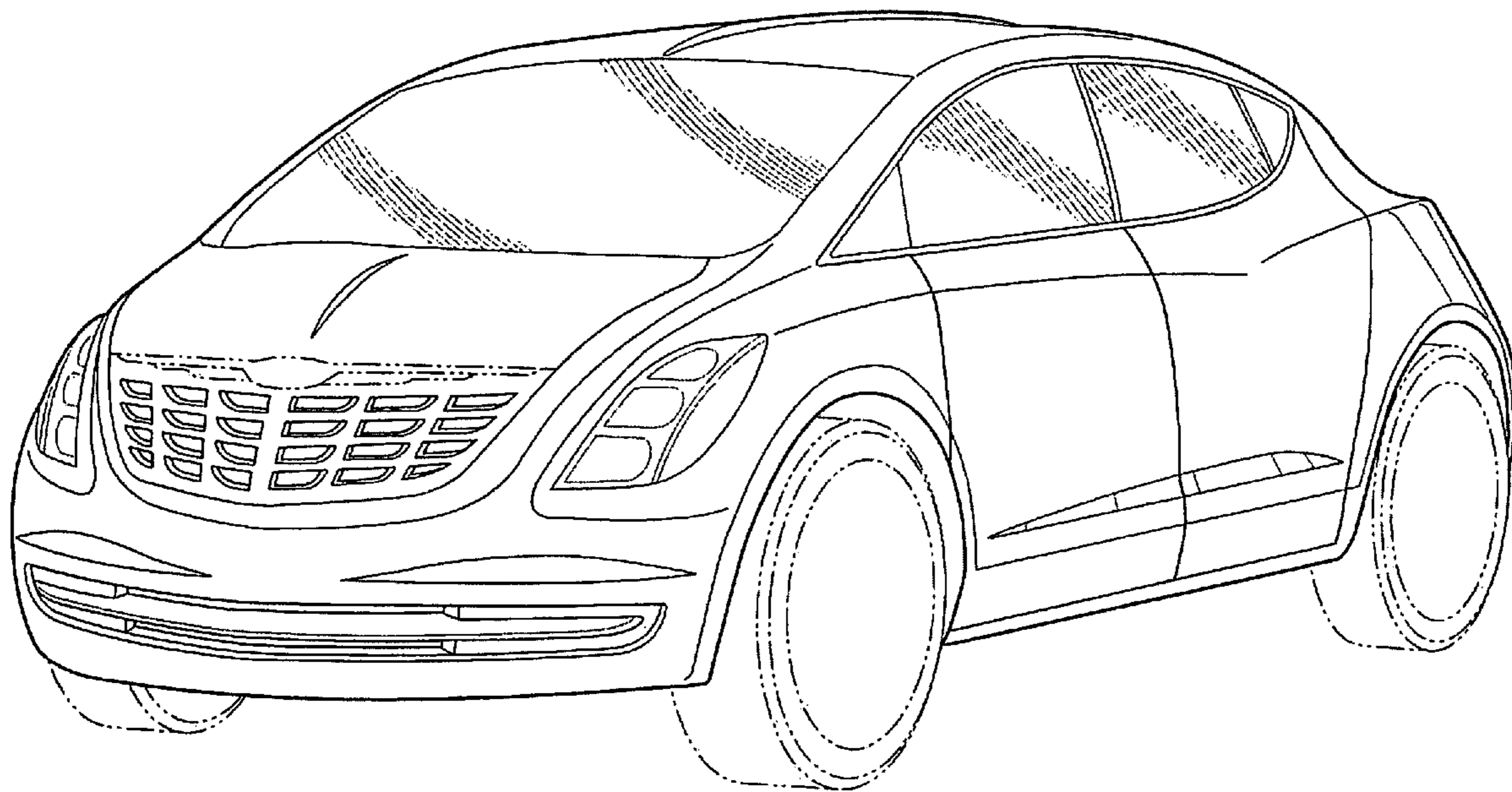

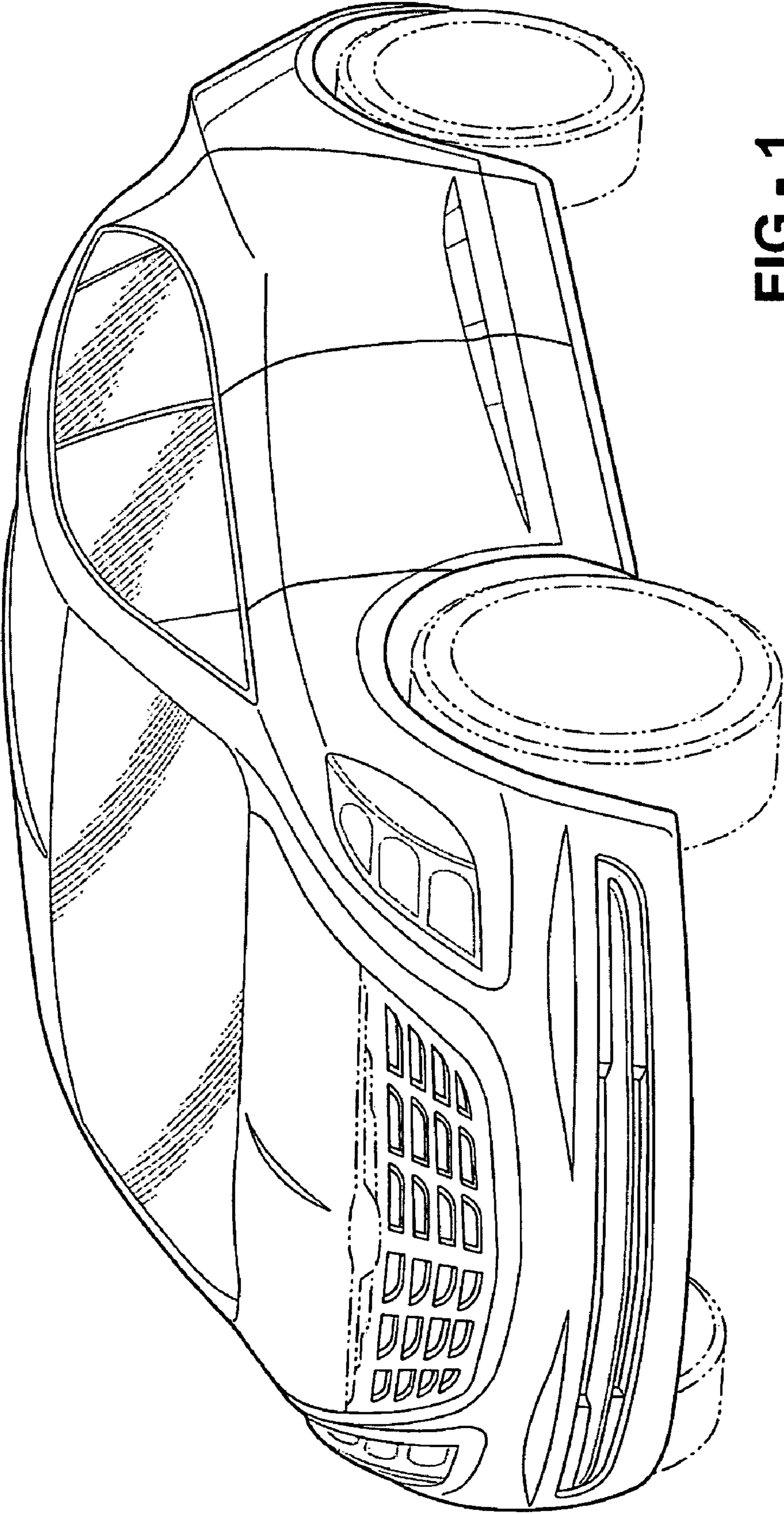

FIG - 1

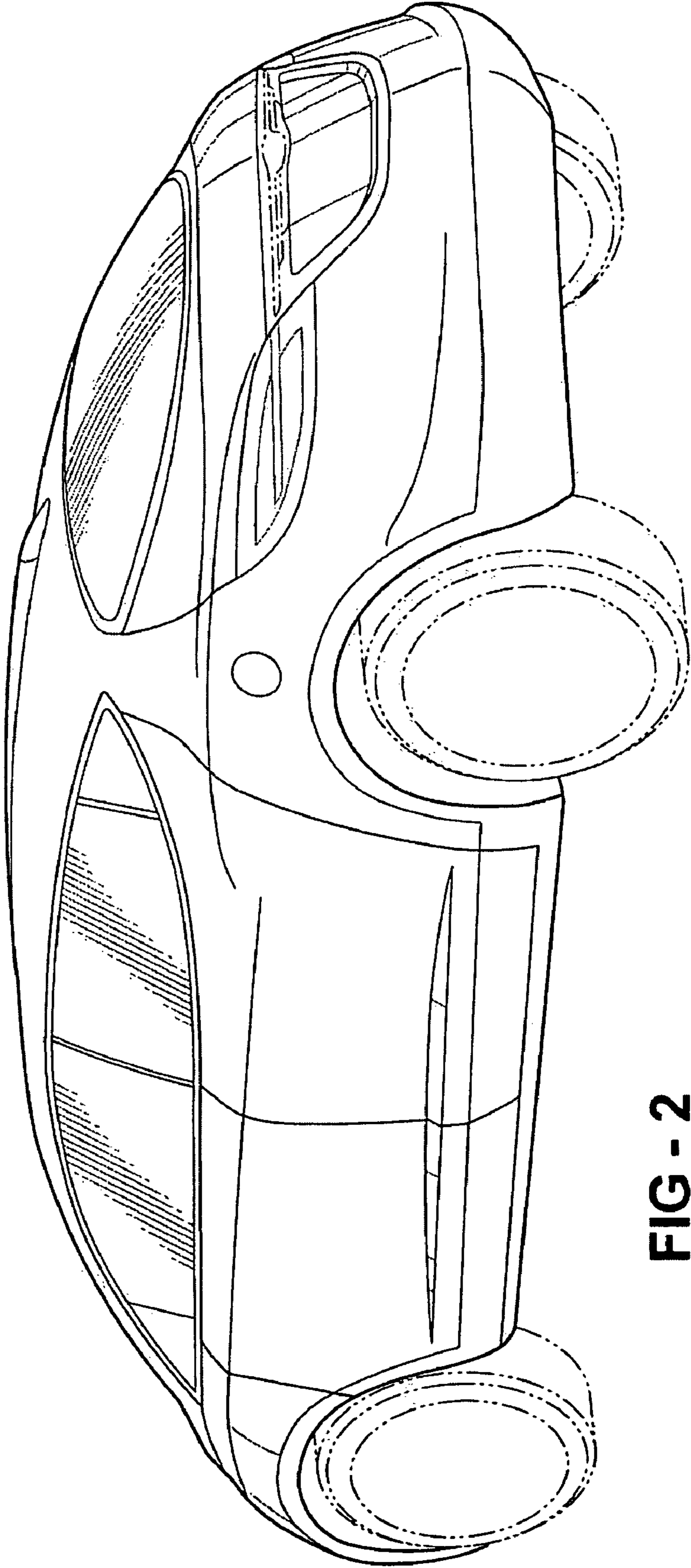

FIG - 2

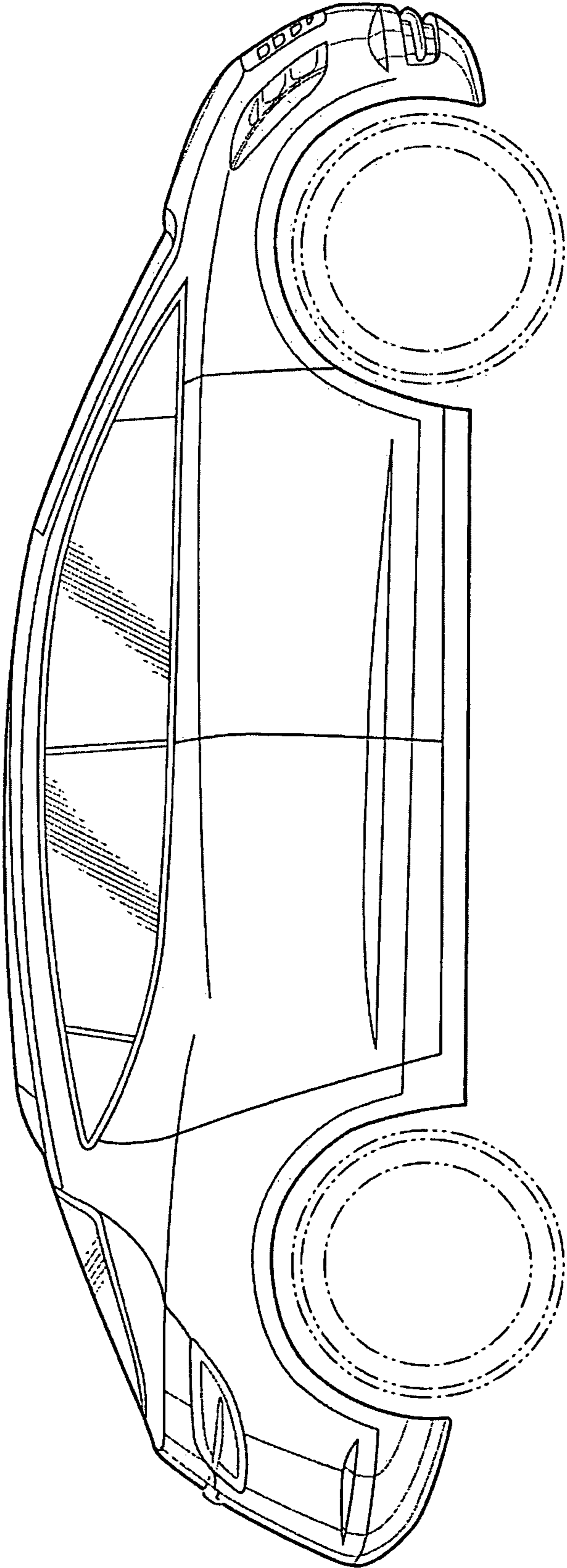
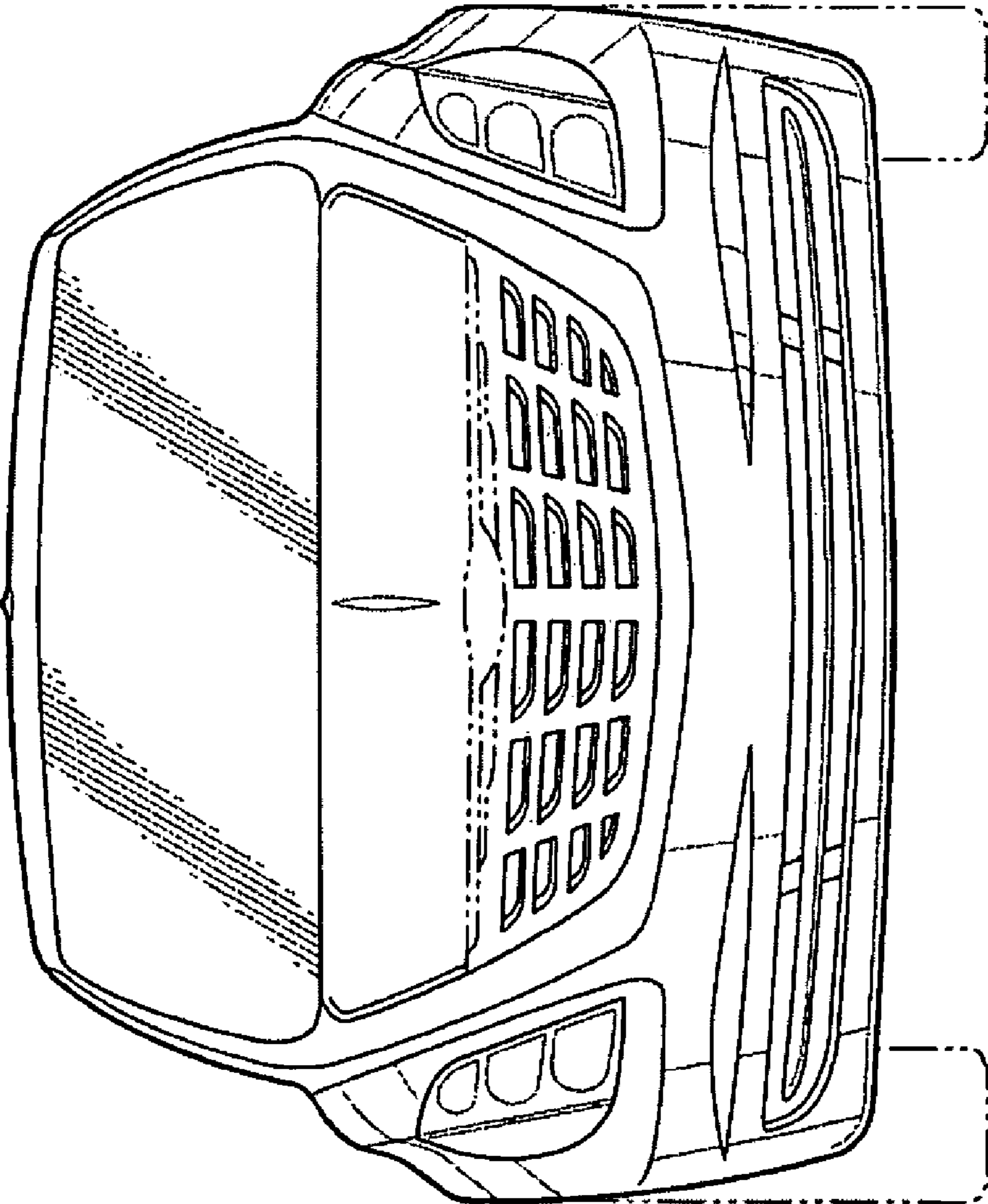

FIG - 3



**FIG - 4**

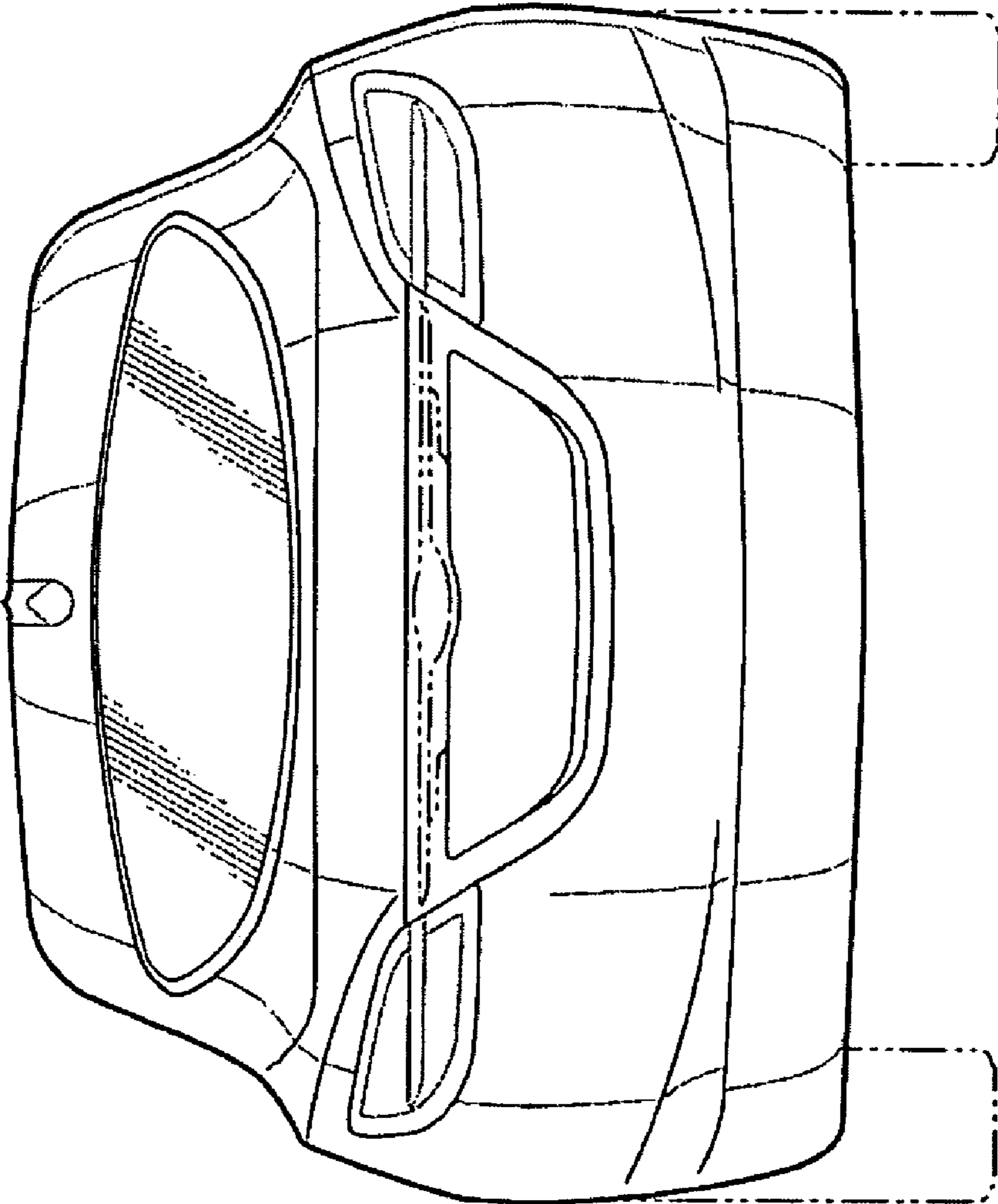

FIG - 5