



US00D588429S

(12) **United States Design Patent**
Misaki et al.

(10) **Patent No.:** **US D588,429 S**
(45) **Date of Patent:** **** Mar. 17, 2009**

(54) **PORTABLE ELECTRIC DRIVER**

(75) Inventors: **Shingo Misaki**, Anjo (JP); **Tomohiro Ukai**, Anjo (JP); **Yuta Matsuura**, Anjo (JP)

(73) Assignee: **Makita Corporation**, Anjo (JP)

(**) Term: **14 Years**

(21) Appl. No.: **29/309,348**

(22) Filed: **Jul. 29, 2008**

(30) **Foreign Application Priority Data**

Feb. 15, 2008 (JP) 2008-003300

(51) **LOC (9) Cl.** **08-01**

(52) **U.S. Cl.** **D8/68**

(58) **Field of Classification Search** D8/61-70;
81/57.11, 429, 454-456, 469, 489; 173/13,
173/104, 114, 167-173, 178, 201, 211, 213,
173/217; 227/8, 113, 114, 120, 130, 136,
227/142; 310/50; 408/20, 124, 125, 234,
408/241 R; 451/358

See application file for complete search history.

(56) **References Cited**

U.S. PATENT DOCUMENTS

D426,125 S 6/2000 Hayakawa et al.
D439,123 S * 3/2001 Sakai et al. D8/68

D486,049 S * 2/2004 Sugiura et al. D8/68
D531,874 S * 11/2006 Wu D8/68
D533,419 S * 12/2006 Aglassinger D8/68
D540,135 S * 4/2007 Okuda D8/68
D563,185 S * 3/2008 Concari D8/68
D566,506 S * 4/2008 Aglassinger D8/68
D567,614 S * 4/2008 Okuda D8/68
2007/0125565 A1 * 6/2007 Etter et al. 173/170
2008/0185993 A1 * 8/2008 Johnson et al. 173/217

* cited by examiner

Primary Examiner—Antoine D Davis

(74) *Attorney, Agent, or Firm*—Oliff & Berridge, PLC

(57) **CLAIM**

The ornamental design for a portable electric driver, as shown and described.

DESCRIPTION

FIG. 1 is a perspective view of a portable electric driver showing our new design;

FIG. 2 is a front elevation view thereof;

FIG. 3 is a rear elevation view thereof;

FIG. 4 is a left side elevation view thereof;

FIG. 5 is a right side elevation view thereof;

FIG. 6 is a top plan view thereof; and,

FIG. 7 is a bottom plan view thereof.

1 Claim, 5 Drawing Sheets

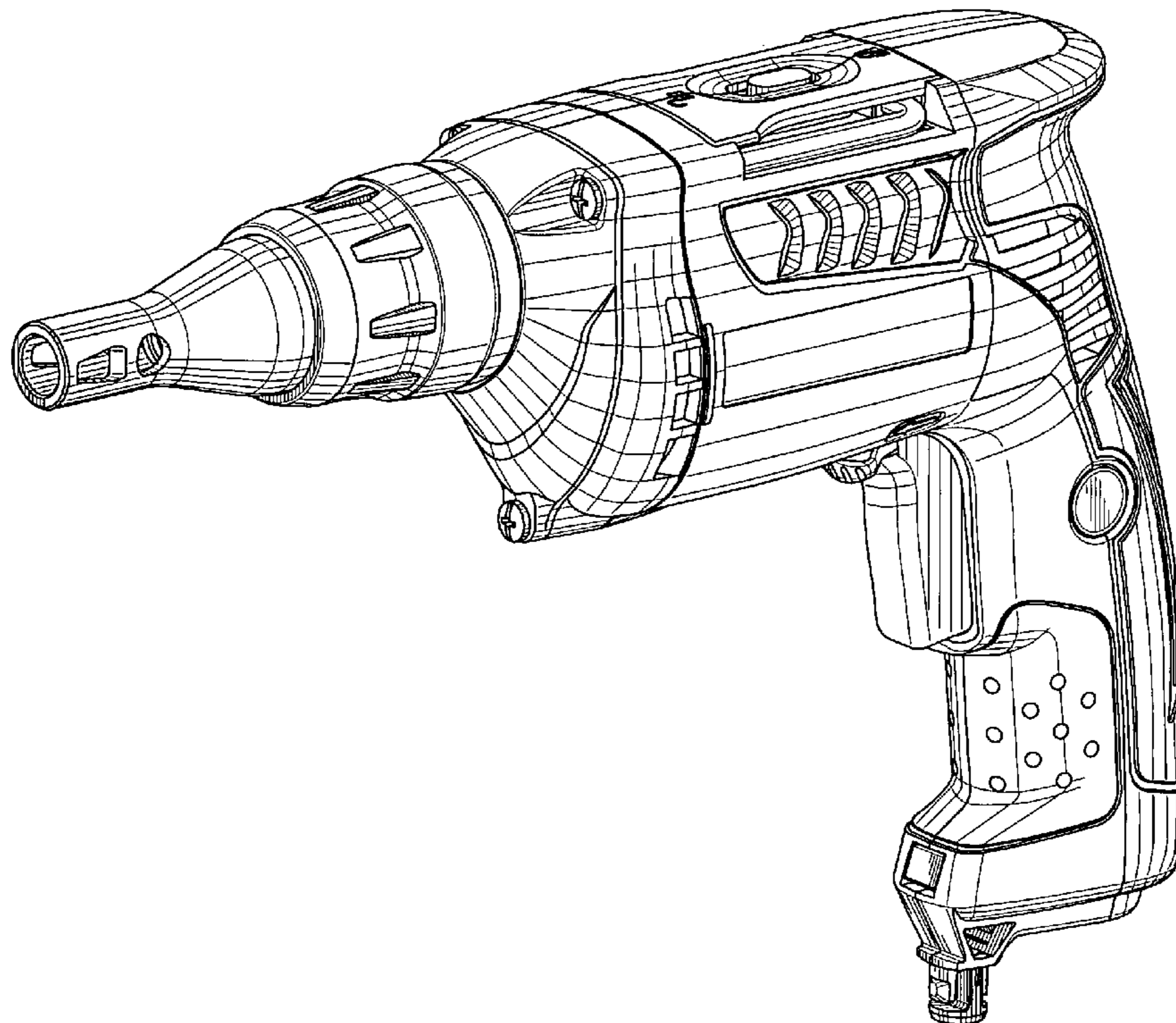

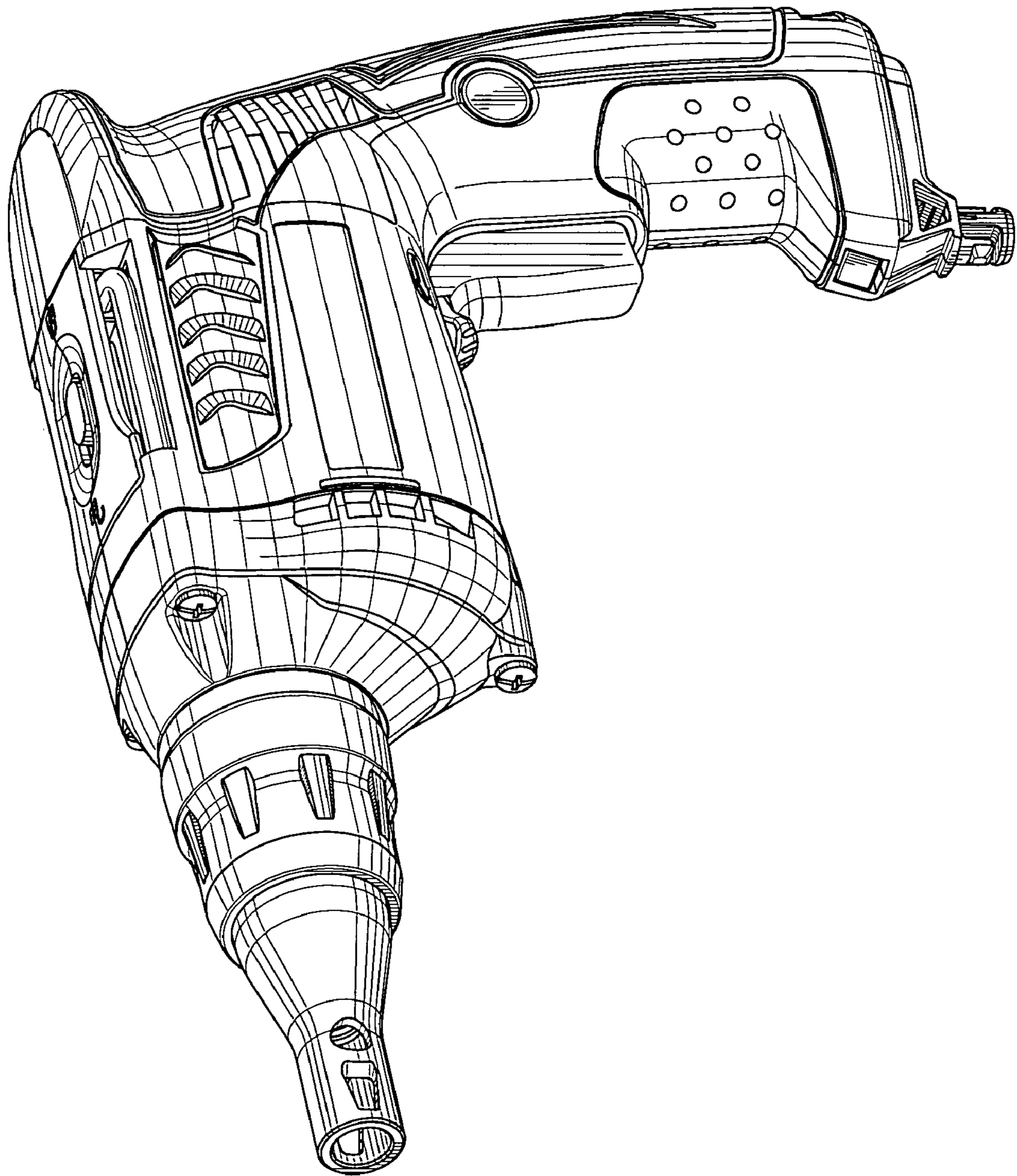

FIG. 1

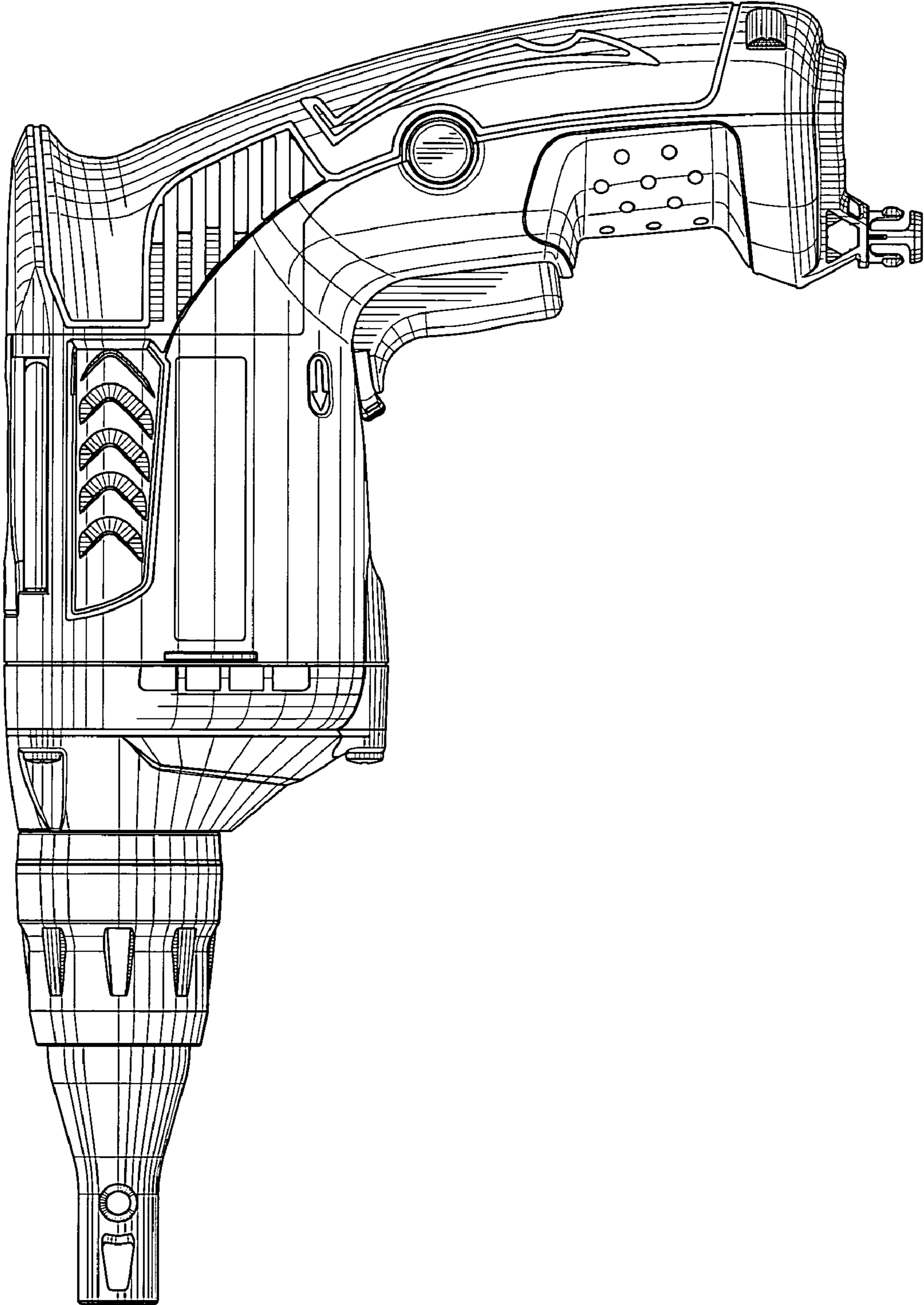

FIG. 2

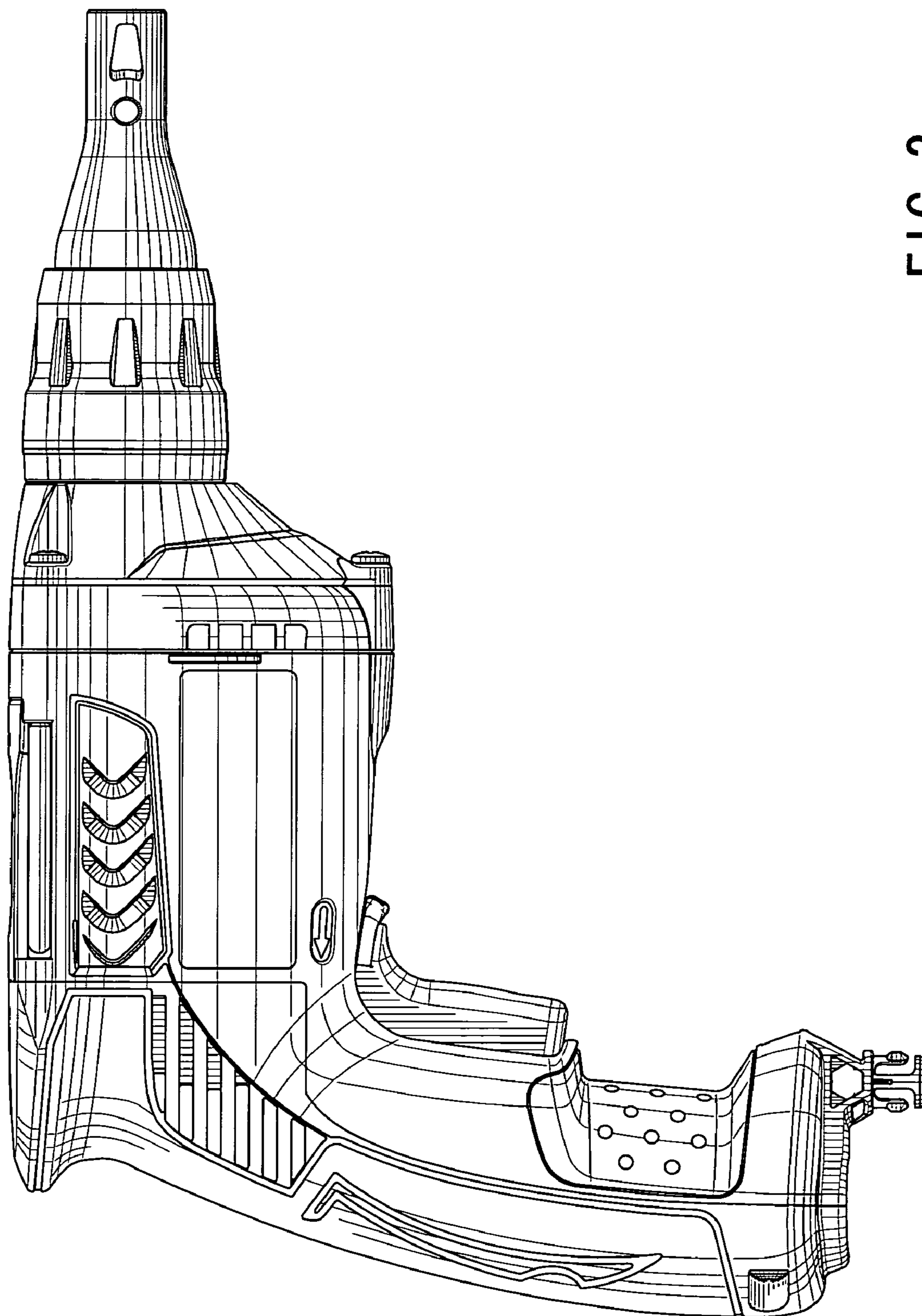

FIG. 3

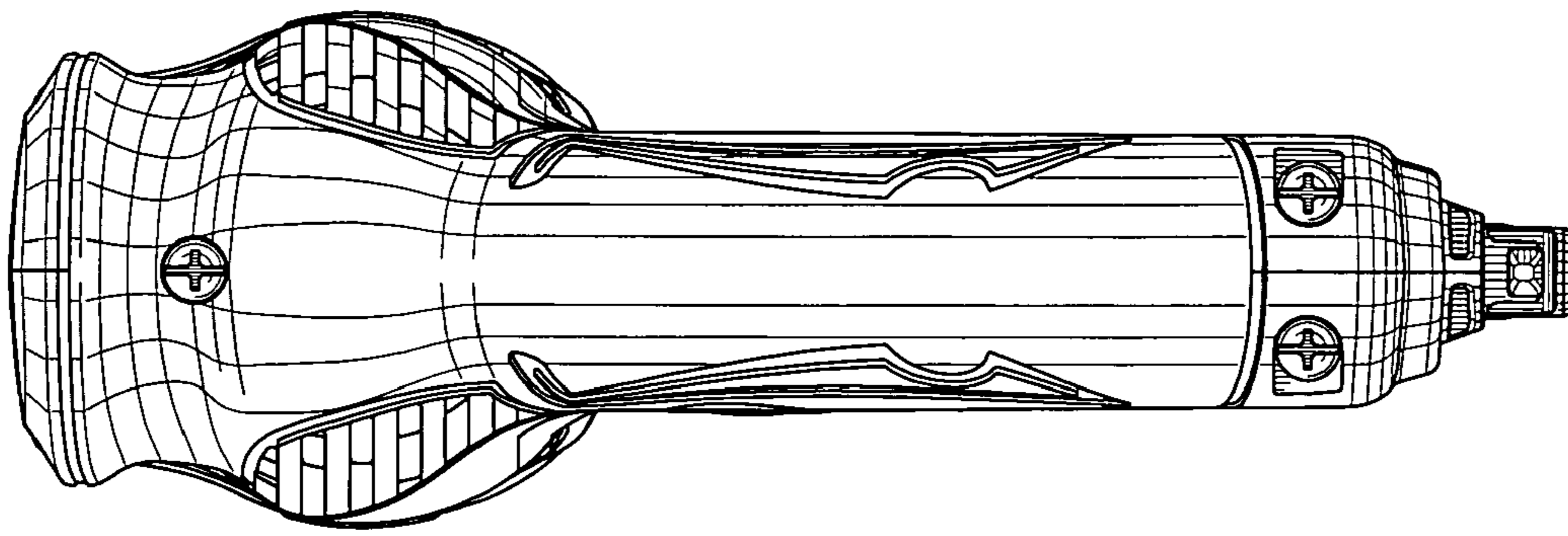

FIG. 5

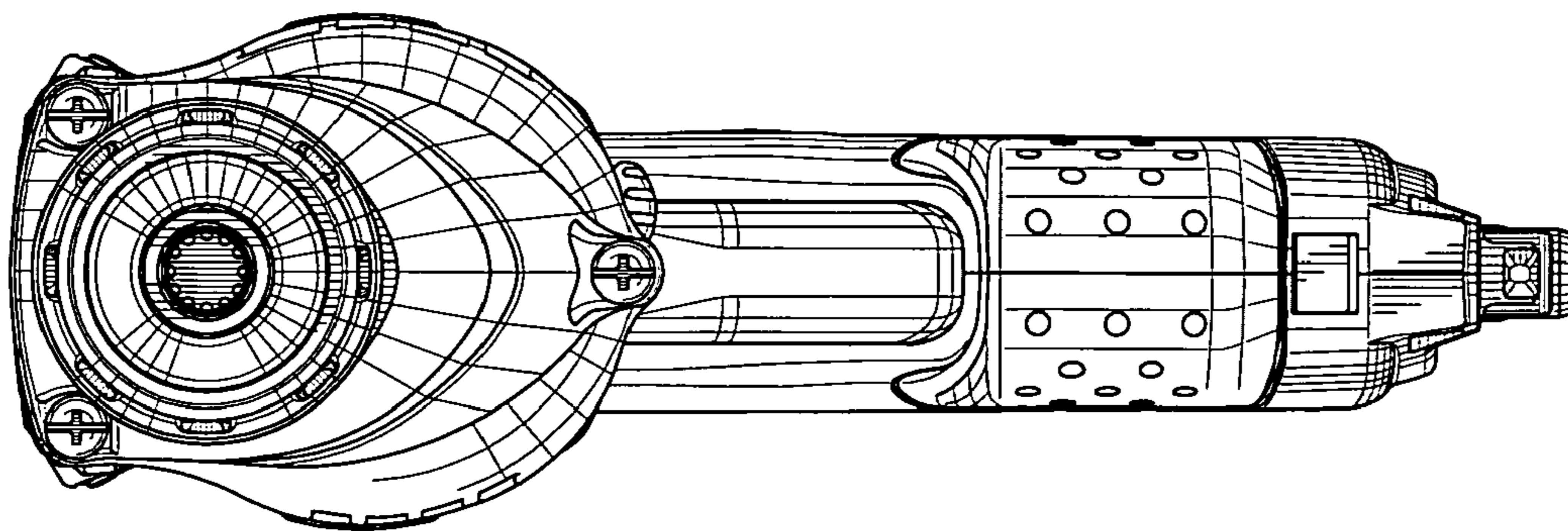

FIG. 4

FIG. 6

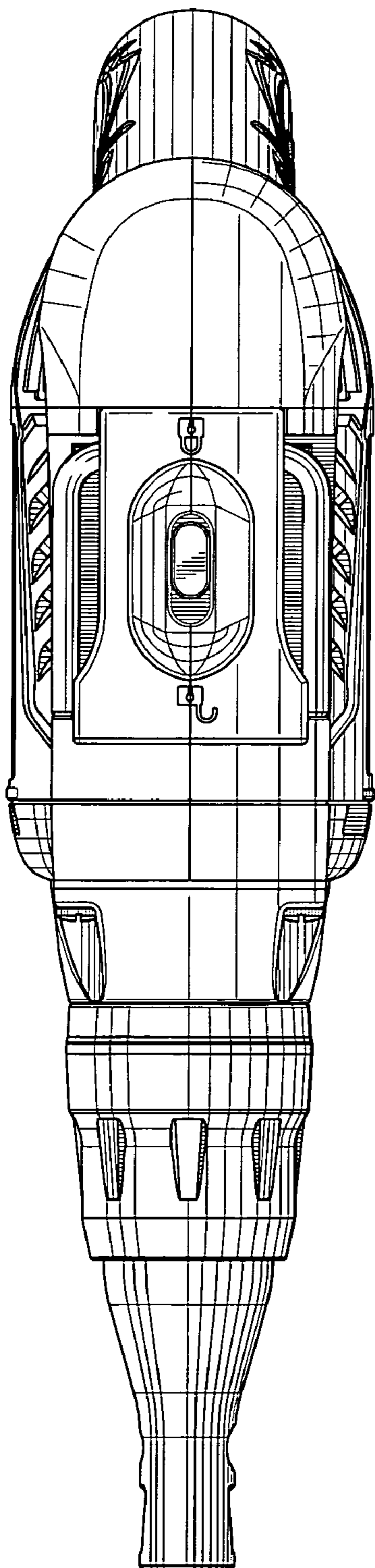

FIG. 7

