



US00D588285S

(12) **United States Design Patent**  
**Muska**

(10) **Patent No.:** **US D588,285 S**

(45) **Date of Patent:** **\*\* Mar. 10, 2009**

(54) **ENERGY ABSORBING APPARATUS**

*Primary Examiner*—T. Chase Nelson  
*Assistant Examiner*—Ania K Dworzecka

(76) **Inventor:** **Martin A. Muska**, 8341 Elmcrest La.,  
Huntington Beach, CA (US) 92646

(57) **CLAIM**

(\*\*) **Term:** **14 Years**

The ornamental design for an energy absorbing apparatus, as shown and described.

(21) **Appl. No.:** **29/296,886**

(22) **Filed:** **Oct. 30, 2007**

**DESCRIPTION**

(51) **LOC (9) Cl.** ..... **25-99**

(52) **U.S. Cl.** ..... **D25/199**

(58) **Field of Classification Search** ..... D25/199,  
D25/133, 131, 68; D8/400, 499, 399, 380,  
D8/349, 354, 373, 356, 352; 52/24, 26, 127.2,  
52/749.126, 698; 182/3, 45, 231; D29/112;  
14/2, 3

The claimed energy absorbing apparatus is used to safeguard structures from external disruptive forces, and may be utilized to protect structures, for example a bridge, by lessening motion transferred to the structures from sources such as earthquakes, strong winds, or explosive blasts.

FIG. 1 is a front plan, fully assembled view of an energy absorbing apparatus showing my new design;

FIG. 2 is a right side elevational view thereof;

FIG. 3 is a exploded front perspective view thereof; and,

FIG. 4 is a fully assembled perspective view thereof.

See application file for complete search history.

In the drawings, the broken lines depict environmental subject matter only and form no part of the claimed design.

(56) **References Cited**

**U.S. PATENT DOCUMENTS**

4,666,130 A \* 5/1987 Denman et al. .... 256/13.1  
D357,172 S \* 4/1995 Hsu ..... D8/354

\* cited by examiner

**1 Claim, 4 Drawing Sheets**

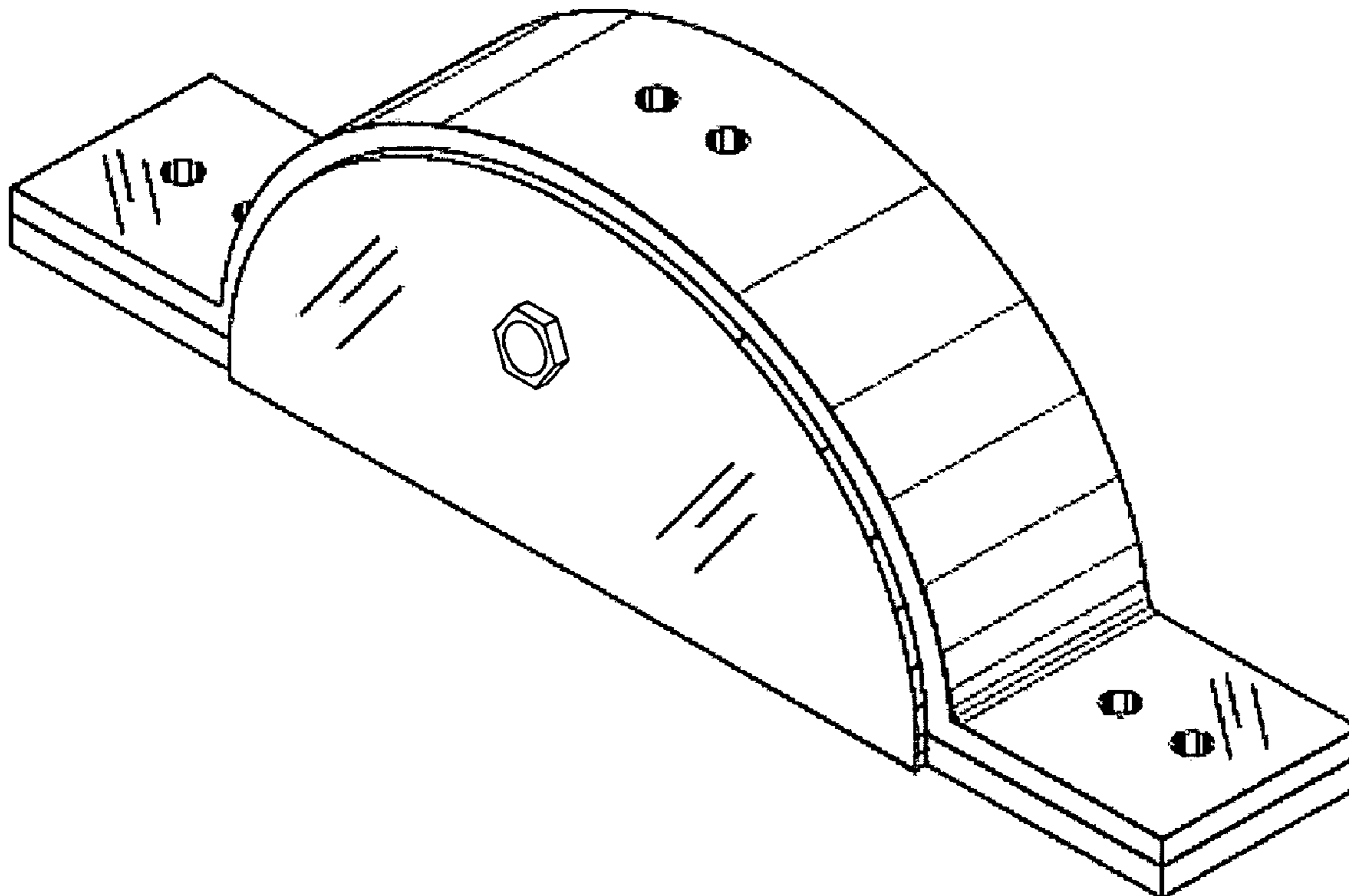

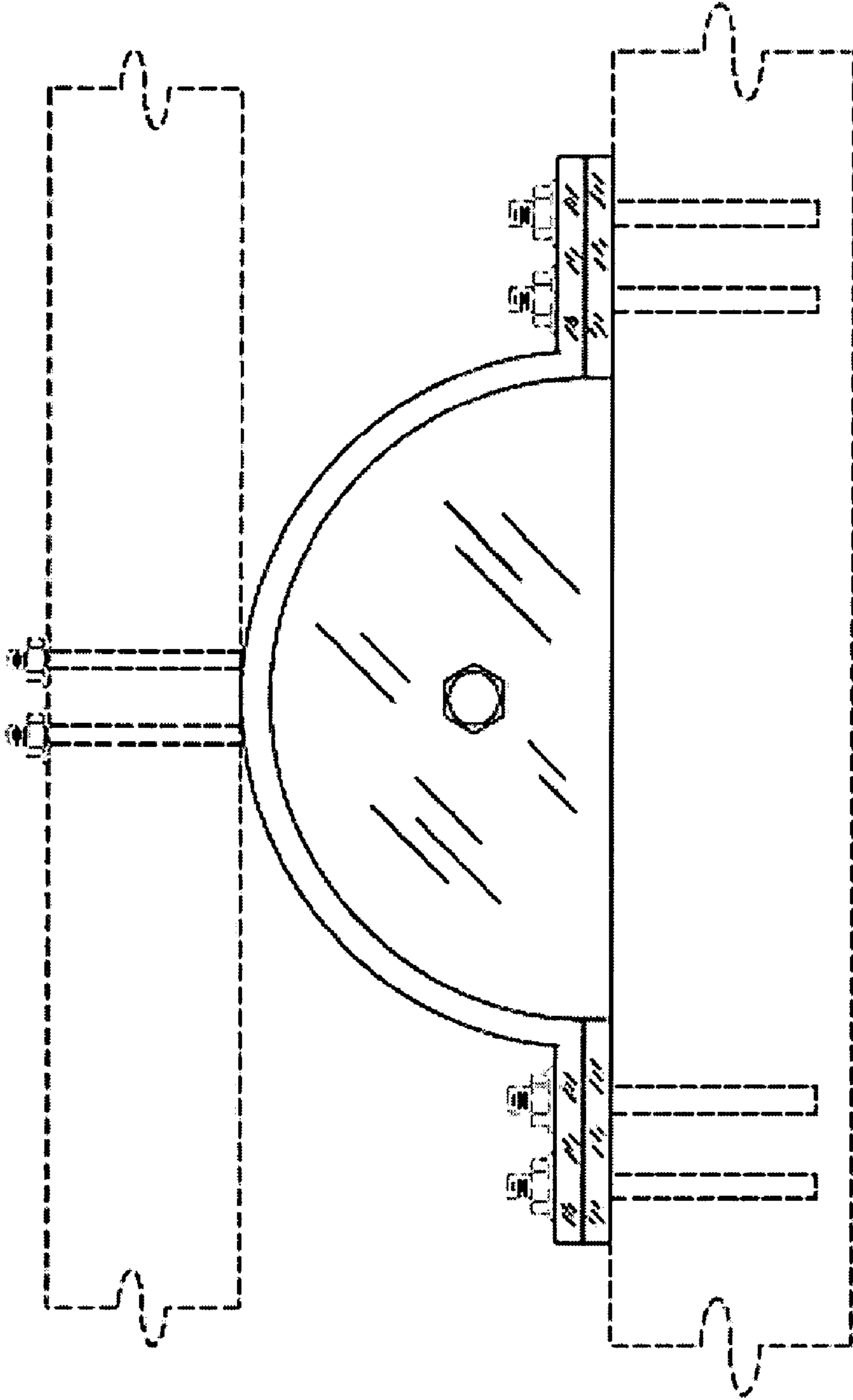

FIG. 1

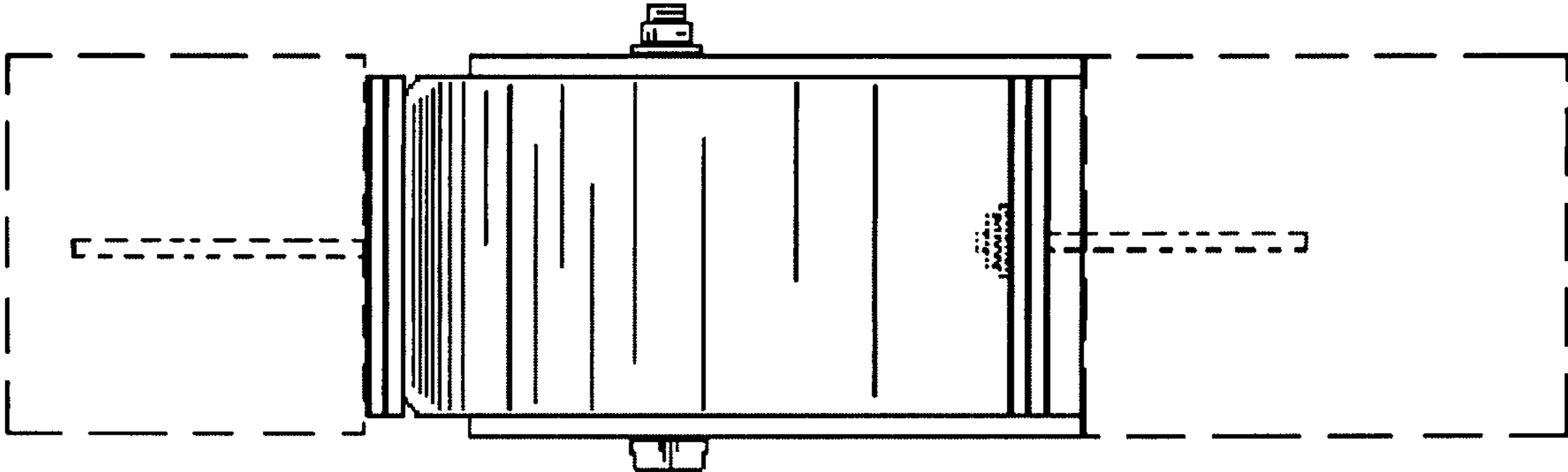
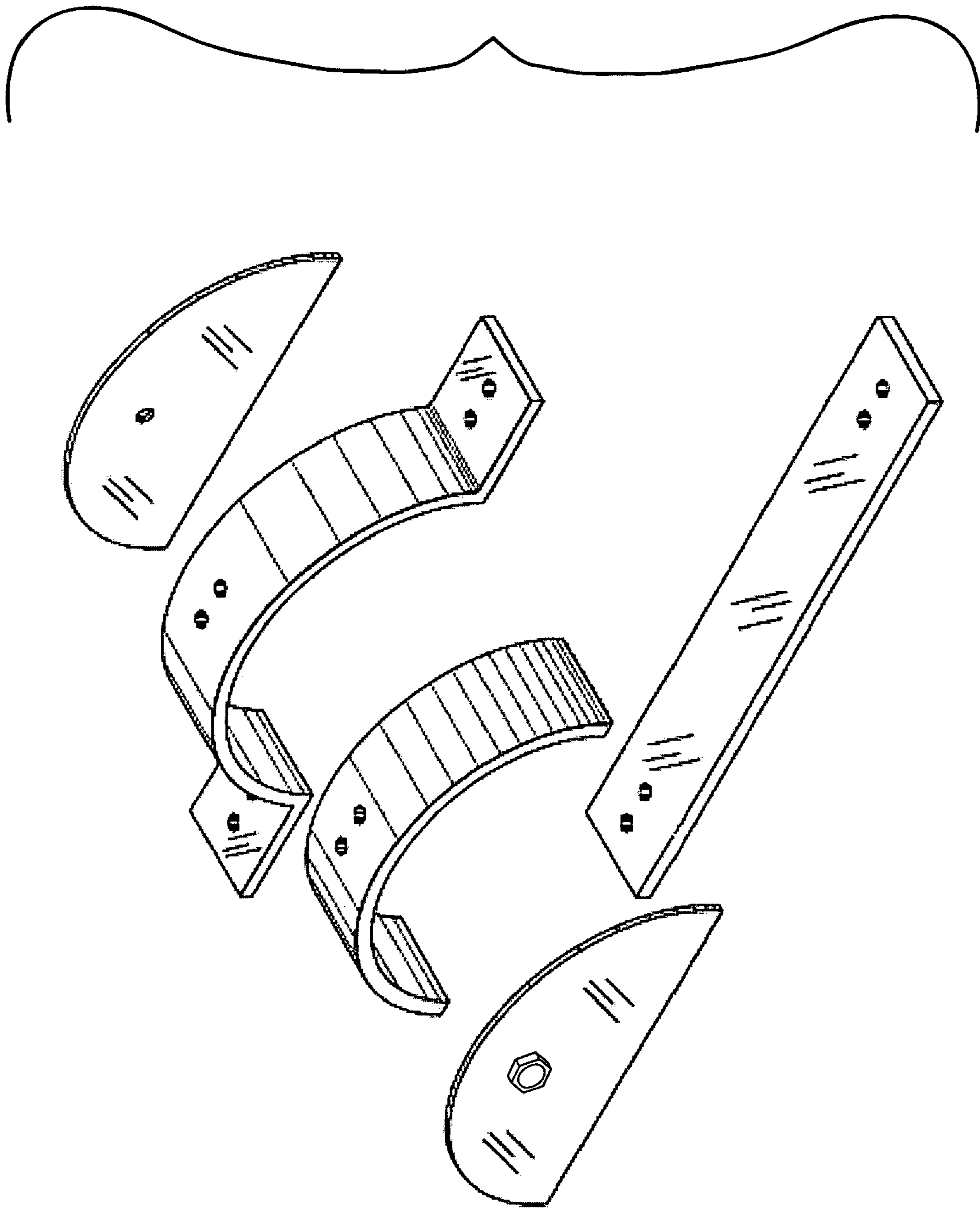
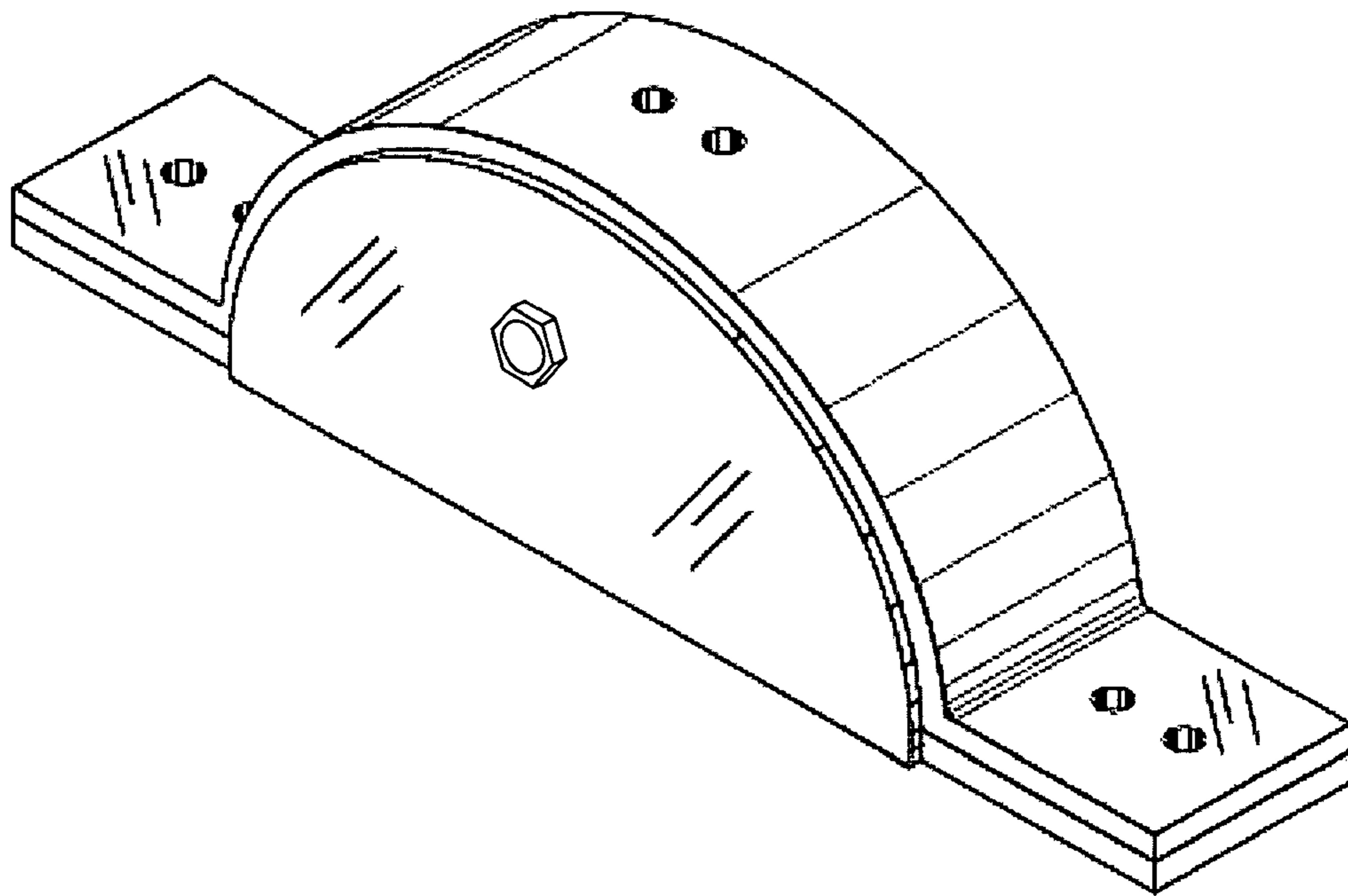

FIG. 2

FIG. 3





*FIG. 4*