



US00D587688S

(12) **United States Design Patent**
Barnes, Jr. et al.

(10) **Patent No.:** **US D587,688 S**
(45) **Date of Patent:** **** Mar. 3, 2009**

(54) **REMOTE CONTROLLER**

DESCRIPTION

(75) Inventors: **Jimmie Barnes, Jr.**, Emporia, KS (US);
Vicki Sickler, Emporia, KS (US)

(73) Assignee: **Hopkins Manufacturing Corp.**,
Emporia, KS (US)

(**) Term: **14 Years**

(21) Appl. No.: **29/296,663**

(22) Filed: **Oct. 25, 2007**

(51) **LOC (9) Cl.** **14-03**

(52) **U.S. Cl.** **D14/218**

(58) **Field of Classification Search** D14/218,
D14/455; D13/168, 162, 164, 169; D21/566;
D10/104, 106, 49; 345/169; 348/14.05,
348/114, 211.99, 734; 455/92, 5, 128, 151.31-151.4,
455/352, 355; 700/65; 341/176

See application file for complete search history.

(56) **References Cited**

U.S. PATENT DOCUMENTS

5,949,379 A * 9/1999 Yang 343/702
2007/0060089 A1 * 3/2007 Owen et al. 455/229

OTHER PUBLICATIONS

Automotive Accessories, <http://www.hoppyonline.com/autoacc/>, 2
pages Nov. 5, 2008.*

* cited by examiner

Primary Examiner—T. Chase Nelson

Assistant Examiner—Ania K Dworzecka

(74) *Attorney, Agent, or Firm*—Sheridan Ross P.C.

(57) **CLAIM**

The ornamental design for a remote controller, as shown and
described.

FIG. 1 is a top perspective view of a remote controller show-
ing our new design;

FIG. 2 is a right elevation view of the design illustrated in FIG.
1, the left elevation view being a mirror image thereof;

FIG. 3 is a front elevation view of the design illustrated in
FIG. 1;

FIG. 4 is a rear elevation view of the design illustrated in FIG.
1;

FIG. 5 is a bottom plan view of the design illustrated in FIG.
1;

FIG. 6 is a top plan view of the design illustrated in FIG. 1;

FIG. 7 is a bottom rear perspective view of the design illus-
trated in FIG. 1;

FIG. 8 is a right elevation view of the design illustrated in FIG.
1 showing a cover in a second position of use, the left eleva-
tion view being a mirror image thereof;

FIG. 9 is a front elevation view of the design illustrated in
FIG. 8;

FIG. 10 is a rear elevation view of the design illustrated in
FIG. 8;

FIG. 11 is a top plan view of the design illustrated in FIG. 8;

FIG. 12 is a right elevation view of the design illustrated in
FIG. 1 showing the cover in a third position of use, the left
elevation view being a mirror image thereof;

FIG. 13 is a front elevation view of the design illustrated in
FIG. 12;

FIG. 14 is a rear elevation view of the design illustrated in
FIG. 12;

FIG. 15 is a top plan view of the design illustrated in FIG. 12;
and,

FIG. 16 is a perspective view showing the remote associated
with the dashboard of a vehicle.

The broken lines in FIGS. 1, 2, 4-8, 10-12, and 14-16 are for
the purpose of illustrating environmental structure and forms
no part of the claimed design.

1 Claim, 6 Drawing Sheets

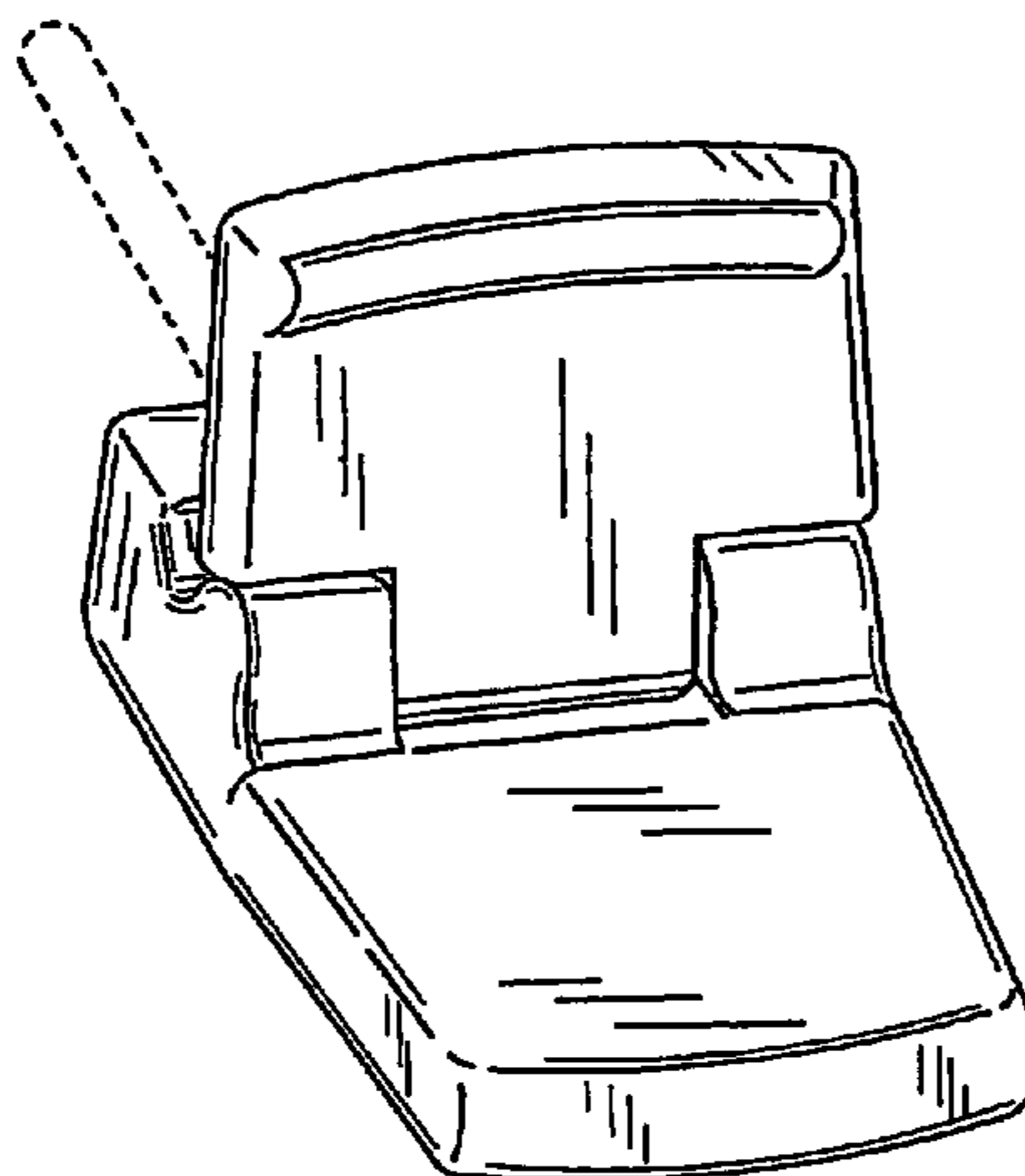
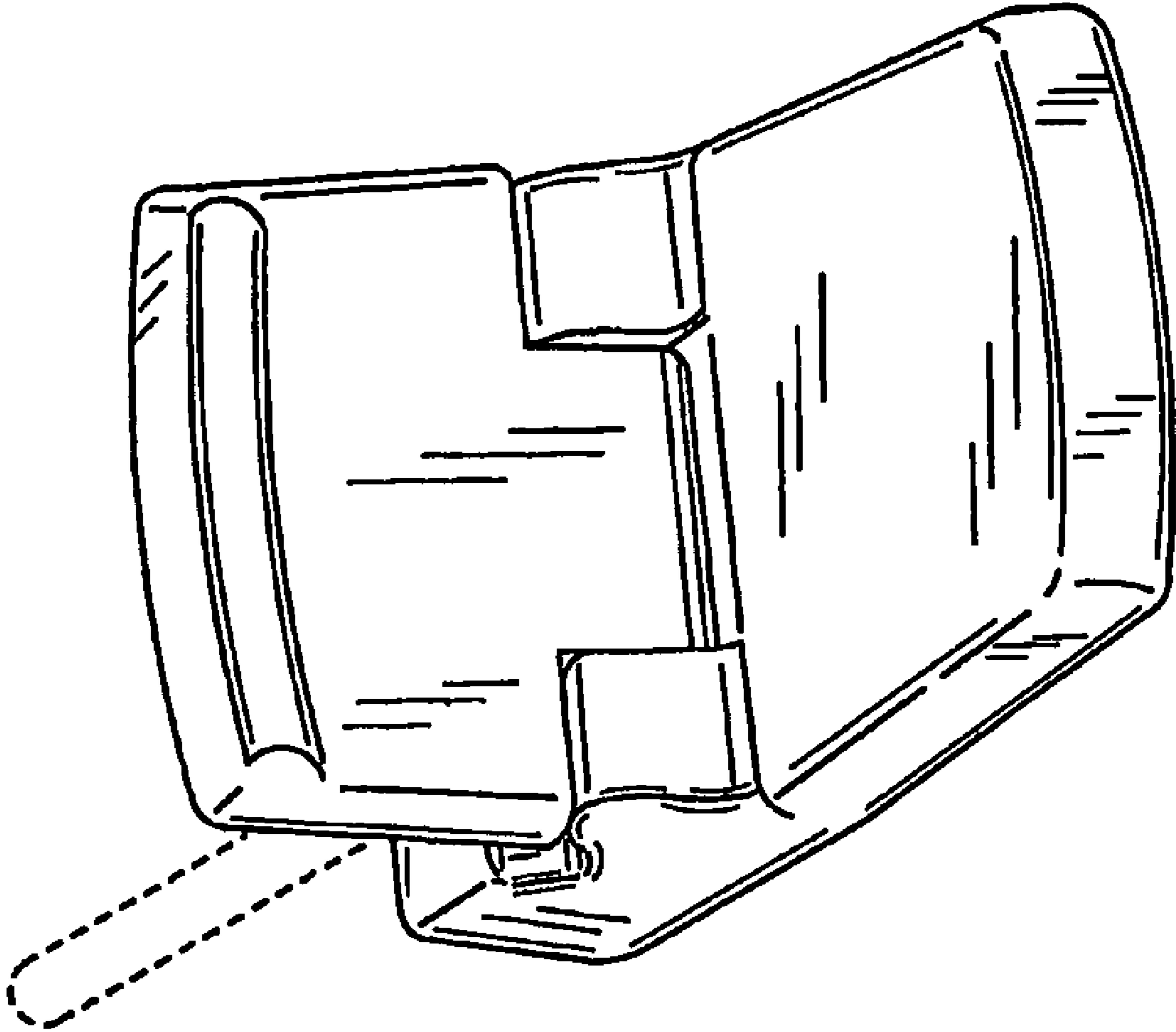

Fig. 1



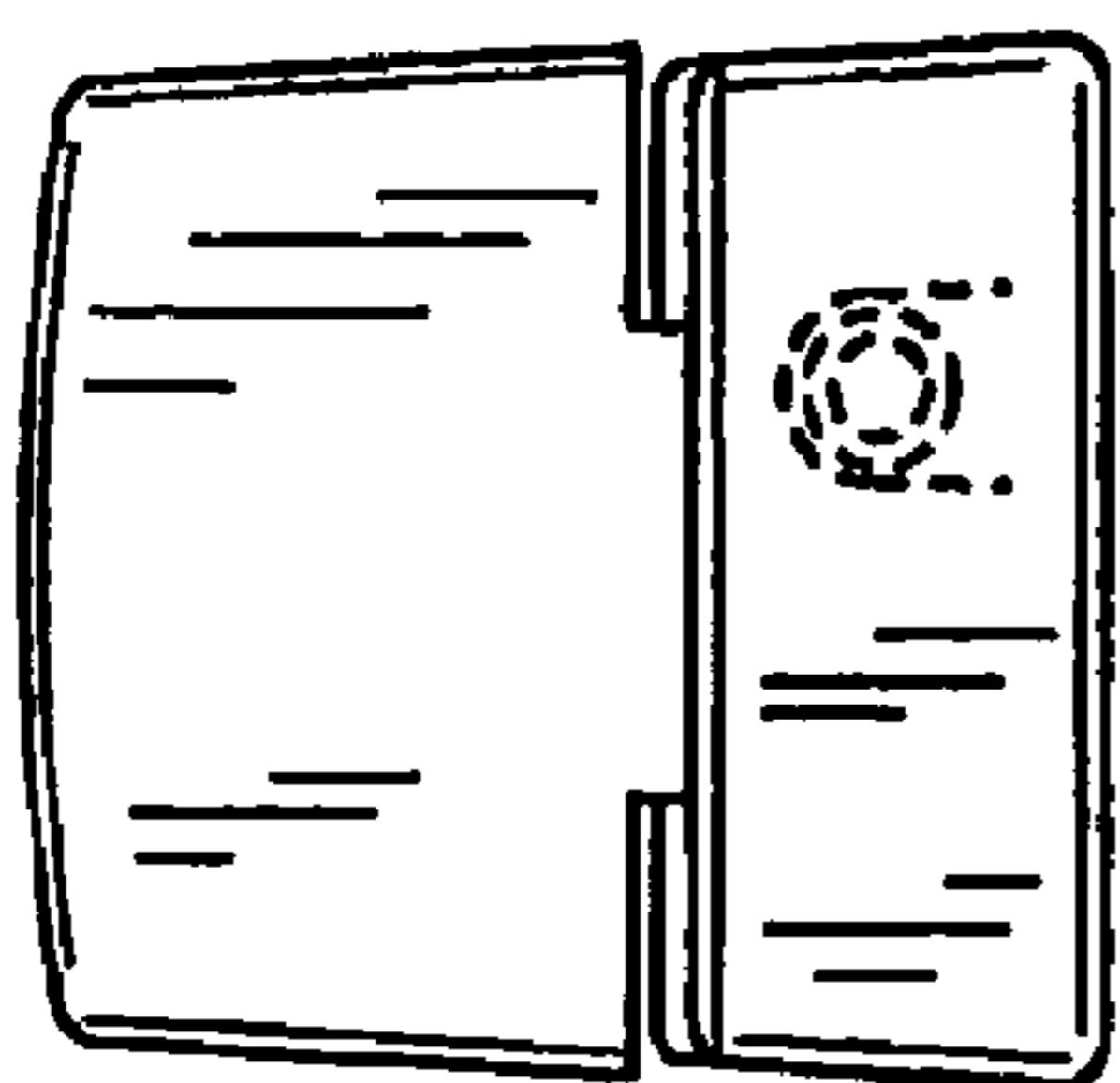

Fig. 4

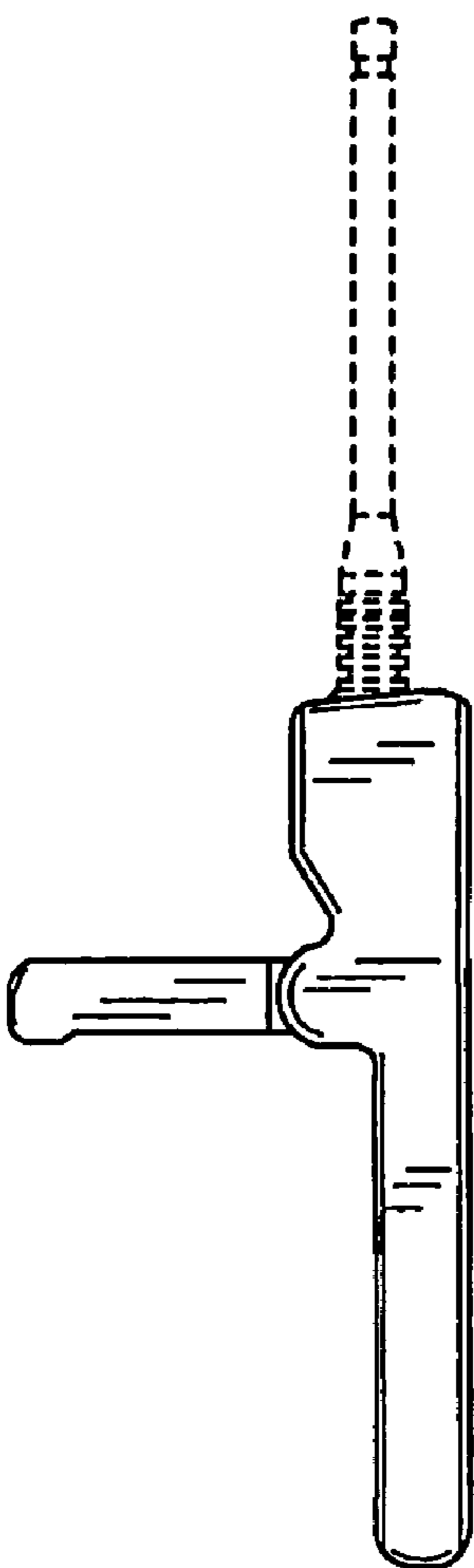

Fig. 2

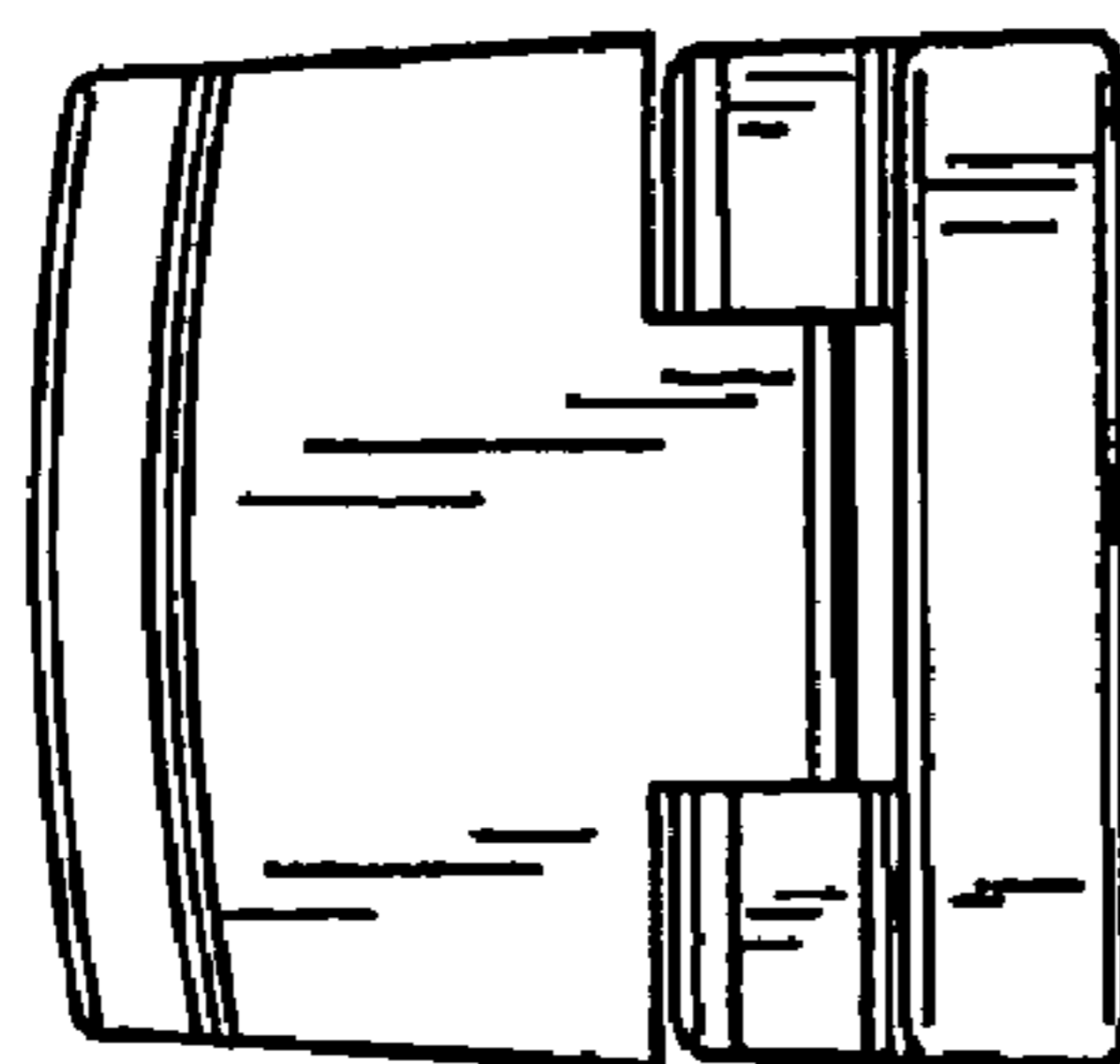

Fig. 3

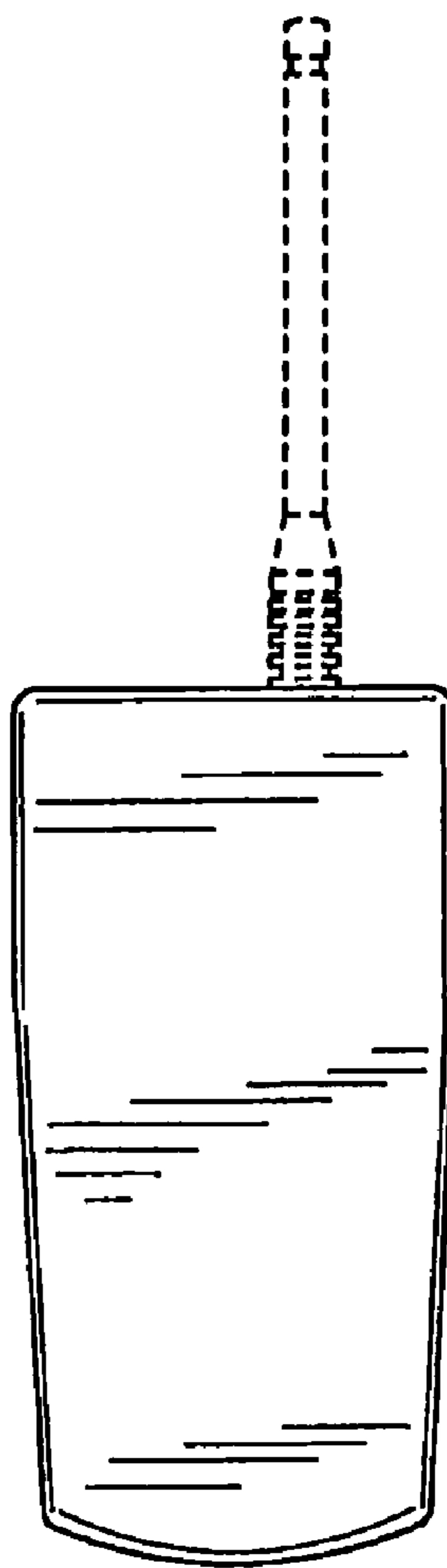

Fig. 5

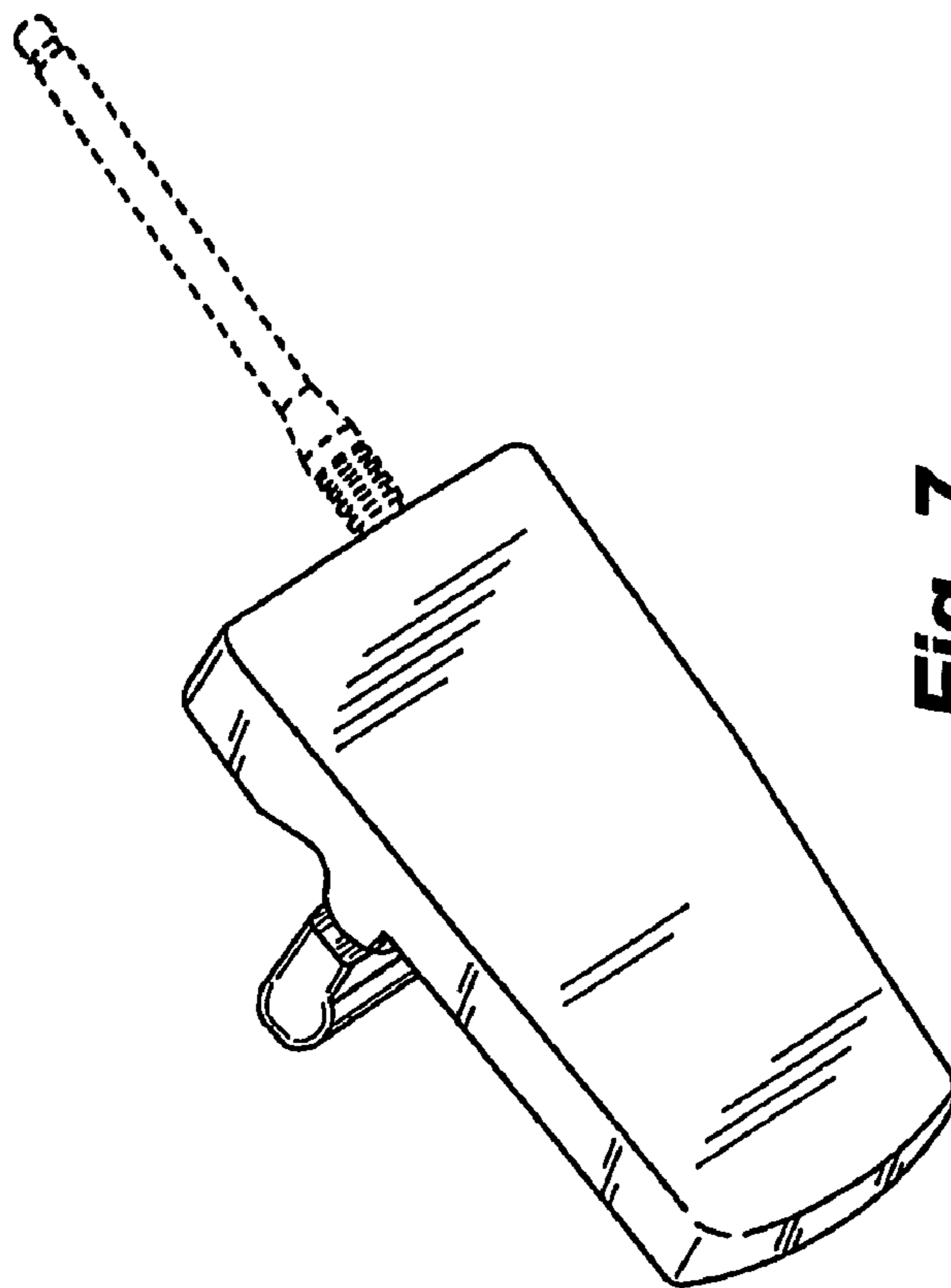

Fig. 7

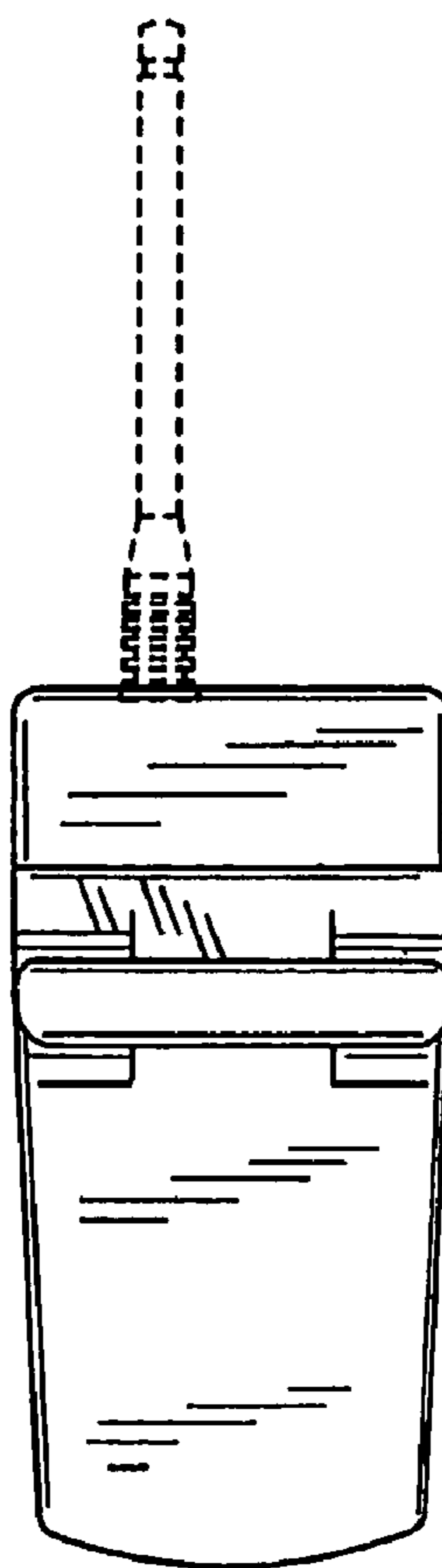

Fig. 6

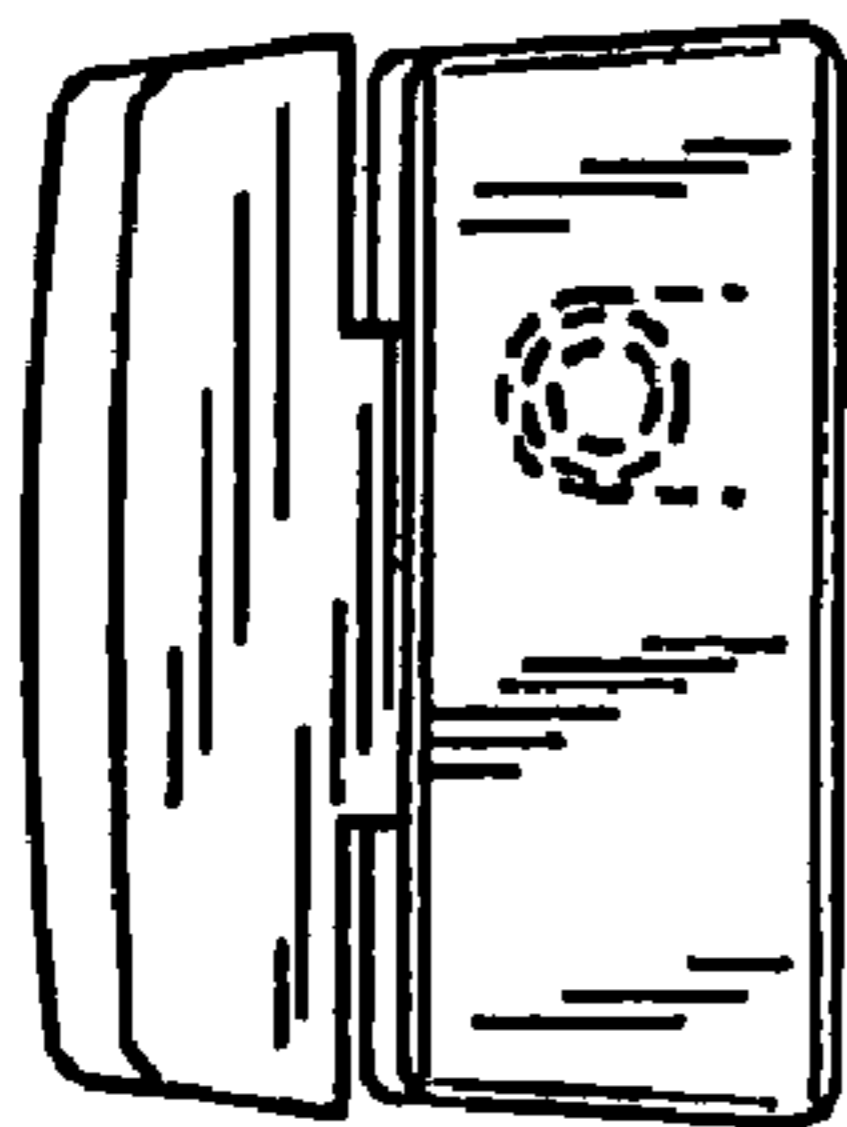

Fig. 10



Fig. 8

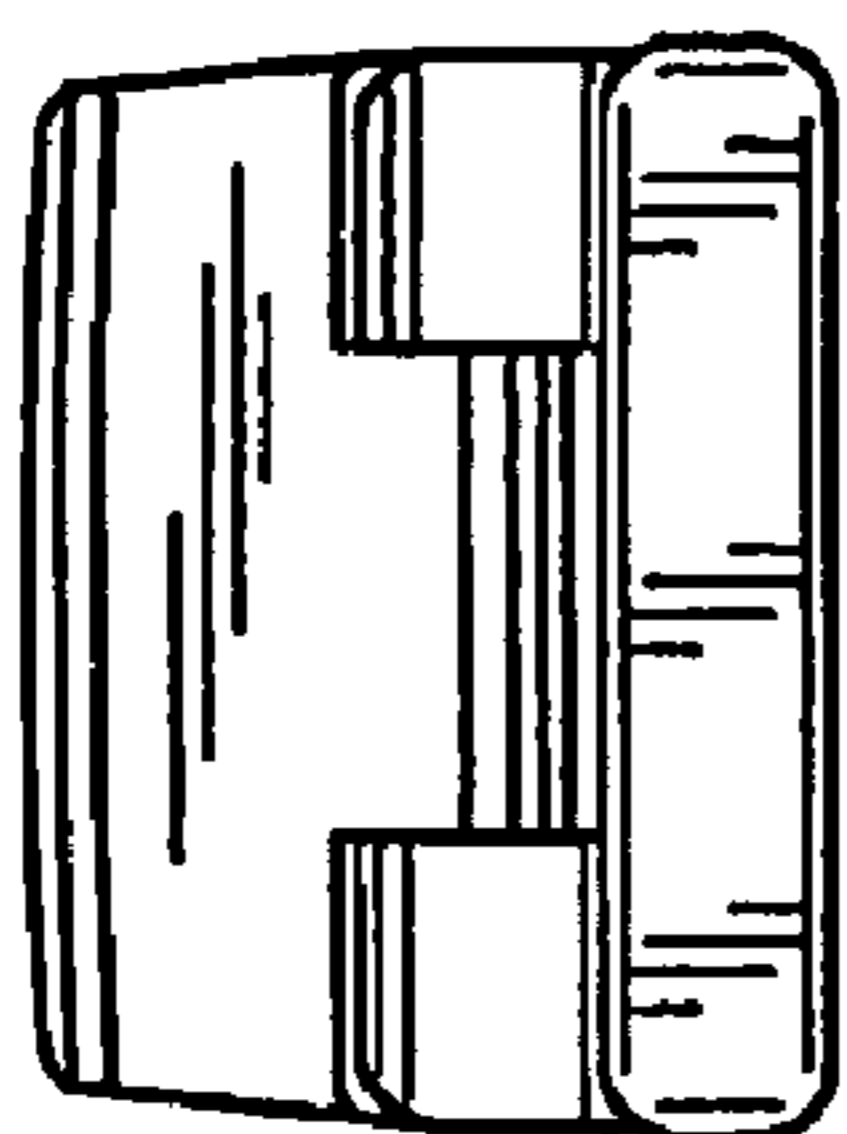

Fig. 9

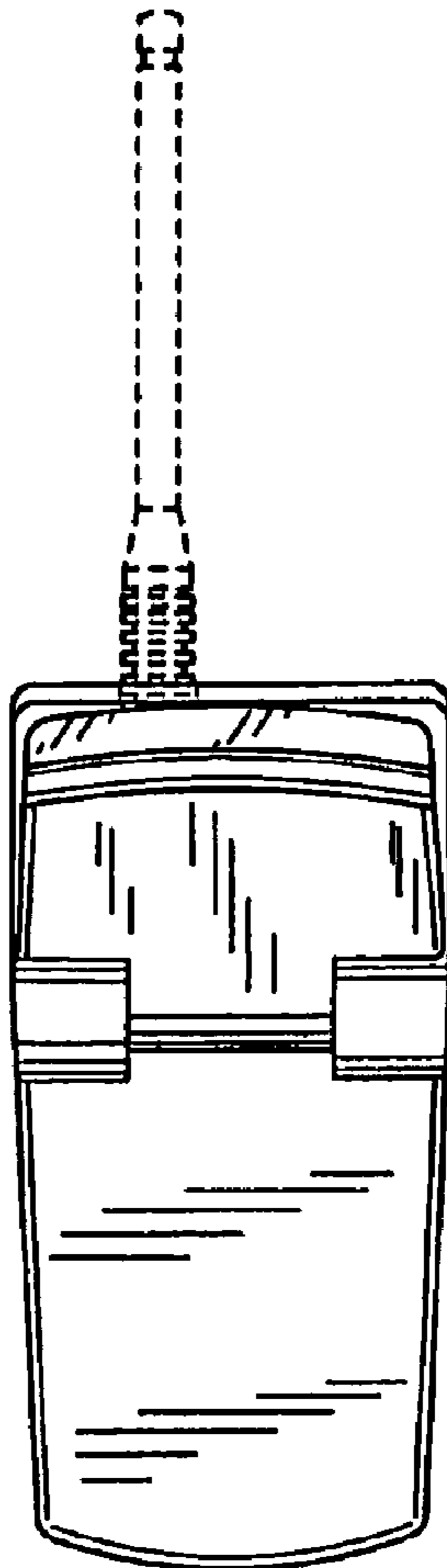

Fig. 11

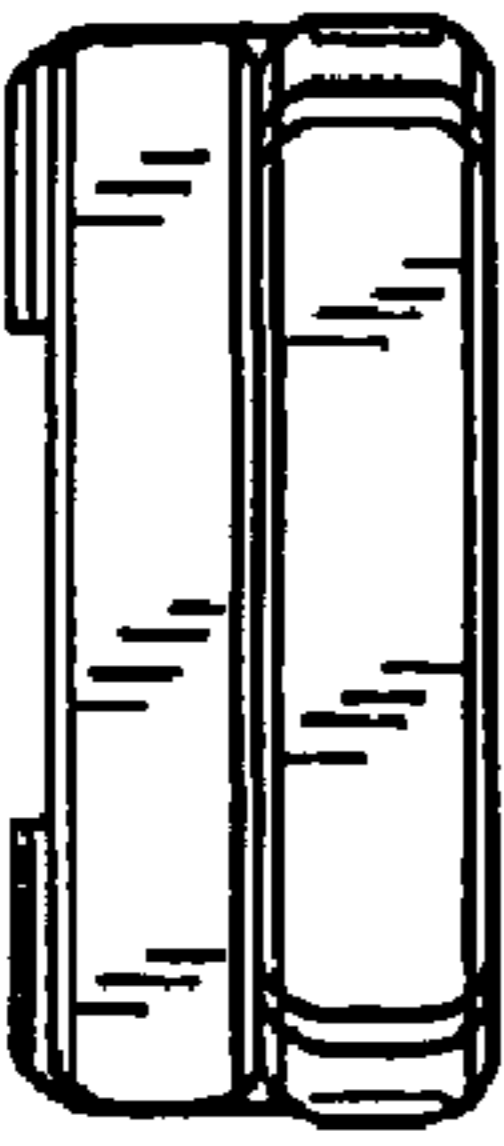

Fig. 13



Fig. 12



Fig. 14

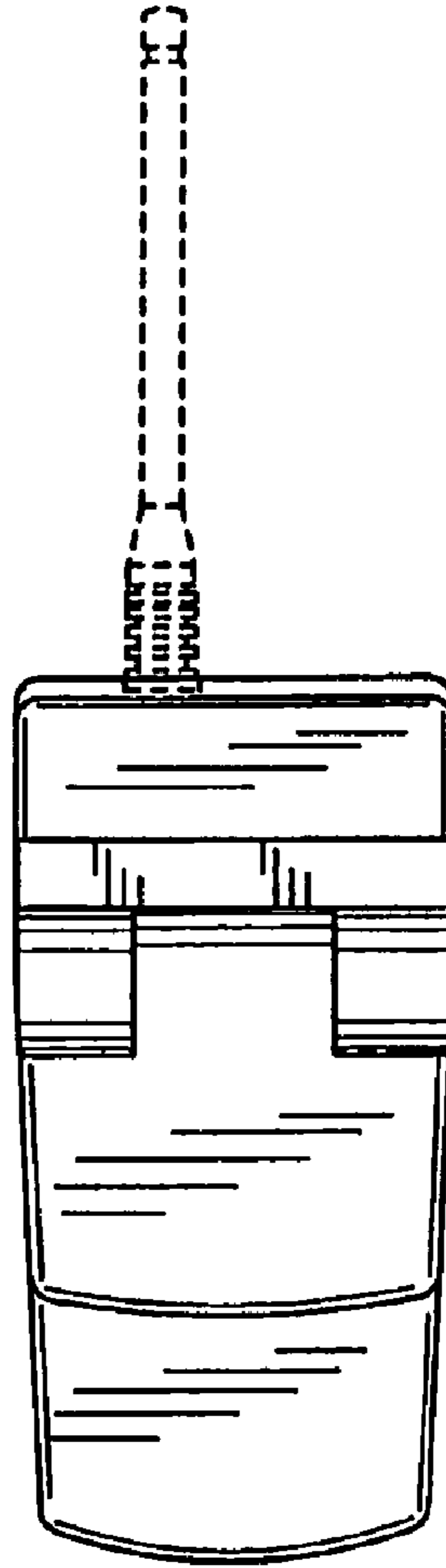

Fig. 15

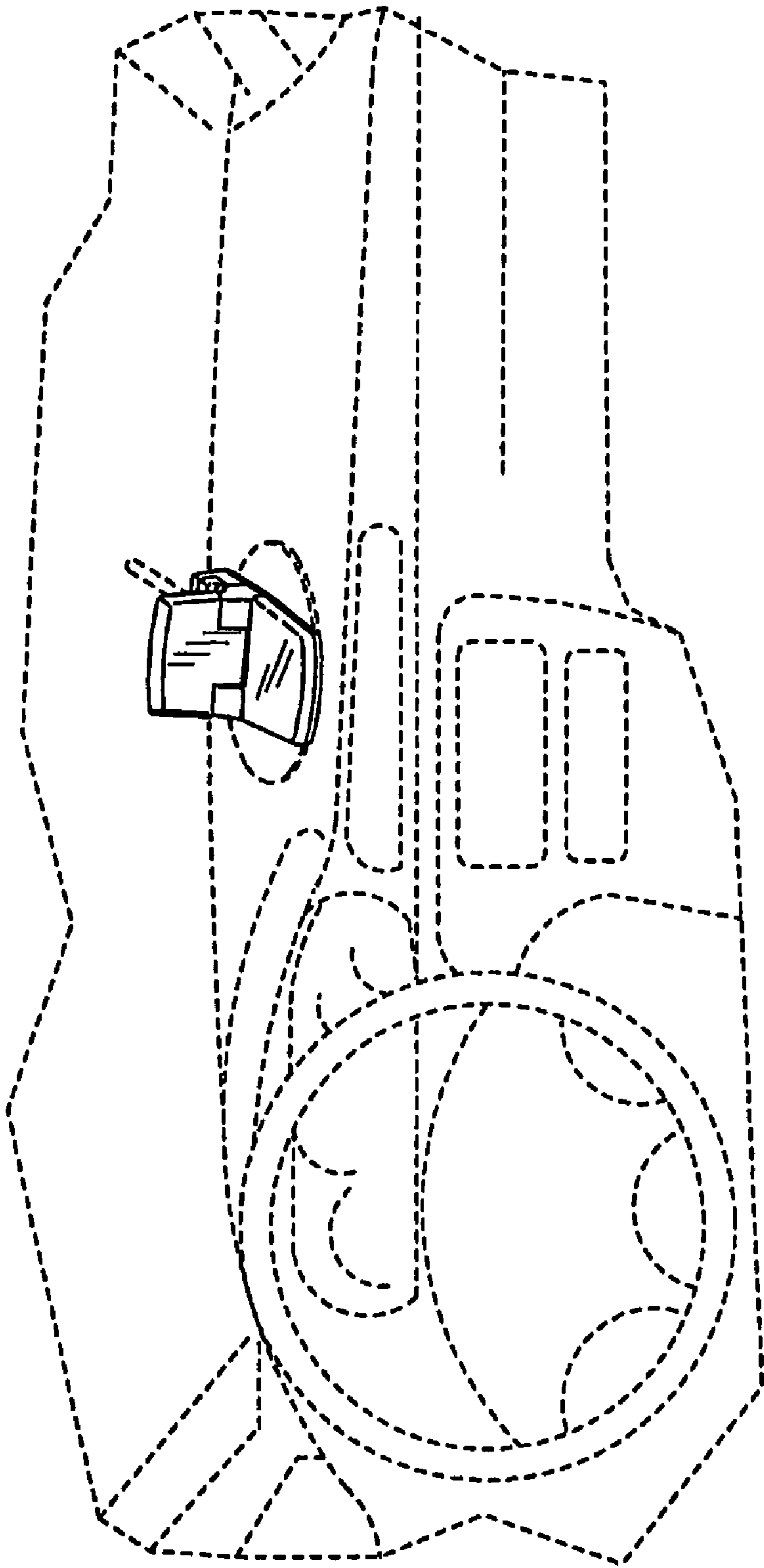

Fig. 16