



US00D587545S

(12) **United States Design Patent**  
**Hayakawa et al.**

(10) **Patent No.:** **US D587,545 S**  
(45) **Date of Patent:** **\*\* Mar. 3, 2009**

(54) **PORTABLE ELECTRIC DRILL**

(75) Inventors: **Naohiro Hayakawa**, Anjo (JP);  
**Kazunori Tsuge**, Anjo (JP)

(73) Assignee: **Makita Corporation**, Anjo-Shi (JP)

(\*\*) Term: **14 Years**

(21) Appl. No.: **29/309,349**

(22) Filed: **Jul. 29, 2008**

(51) **LOC (9) Cl.** ..... **08-01**

(52) **U.S. Cl.** ..... **D8/68**

(58) **Field of Classification Search** ..... D8/14.1,  
D8/61-70; 81/57.11, 429, 454-456, 469,  
81/489; 173/13, 104, 114, 168-171, 178,  
173/201, 211, 213, 217; 408/20, 124, 125,  
408/234, 241 R; 451/358; 310/50; 227/8,  
227/113, 114, 120, 130, 136, 142

See application file for complete search history.

(56) **References Cited**

**U.S. PATENT DOCUMENTS**

D400,415 S *	11/1998	Zurwelle	.....	D8/68
D400,416 S *	11/1998	Zurwelle	.....	D8/68
D402,872 S *	12/1998	Clowers et al.	.....	D8/68
D406,741 S *	3/1999	Zurwelle	.....	D8/68
D426,125 S *	6/2000	Hayakawa et al.	.....	D8/68
D439,123 S *	3/2001	Sakai et al.	.....	D8/68
6,240,816 B1 *	6/2001	Riedl et al.	.....	81/429
D466,779 S *	12/2002	Shibata et al.	.....	D8/68
D467,481 S *	12/2002	Watson	.....	D8/68
D482,254 S *	11/2003	Tsuzuki et al.	.....	D8/68

D486,049 S *	2/2004	Sugiura et al.	.....	D8/68
6,729,414 B2 *	5/2004	Cooper et al.	.....	173/217
D492,565 S *	7/2004	Stirm	.....	D8/68
D531,874 S *	11/2006	Wu	.....	D8/68
D533,419 S *	12/2006	Aglassinger	.....	D8/68
D533,420 S *	12/2006	Waldron	.....	D8/68
D534,405 S *	1/2007	Concari	.....	D8/68
D540,135 S *	4/2007	Okuda	.....	D8/68
D563,185 S *	3/2008	Concari	.....	D8/68
D567,614 S *	4/2008	Okuda	.....	D8/68
7,398,834 B2 *	7/2008	Jung et al.	.....	173/4
7,401,663 B2 *	7/2008	Craven et al.	.....	173/217

\* cited by examiner

*Primary Examiner*—Antoine D Davis

(74) *Attorney, Agent, or Firm*—Oliff & Berridge, PLC

(57) **CLAIM**

The ornamental design for a portable electric drill, as shown and described.

**DESCRIPTION**

FIG. 1 is a perspective view of a portable electric drill showing our new design;

FIG. 2 is a front elevation view thereof;

FIG. 3 is a rear elevation view thereof;

FIG. 4 is a left side elevation view thereof;

FIG. 5 is a right side elevation view thereof;

FIG. 6 is a top plan view thereof; and,

FIG. 7 is a bottom plan view thereof.

**1 Claim, 5 Drawing Sheets**

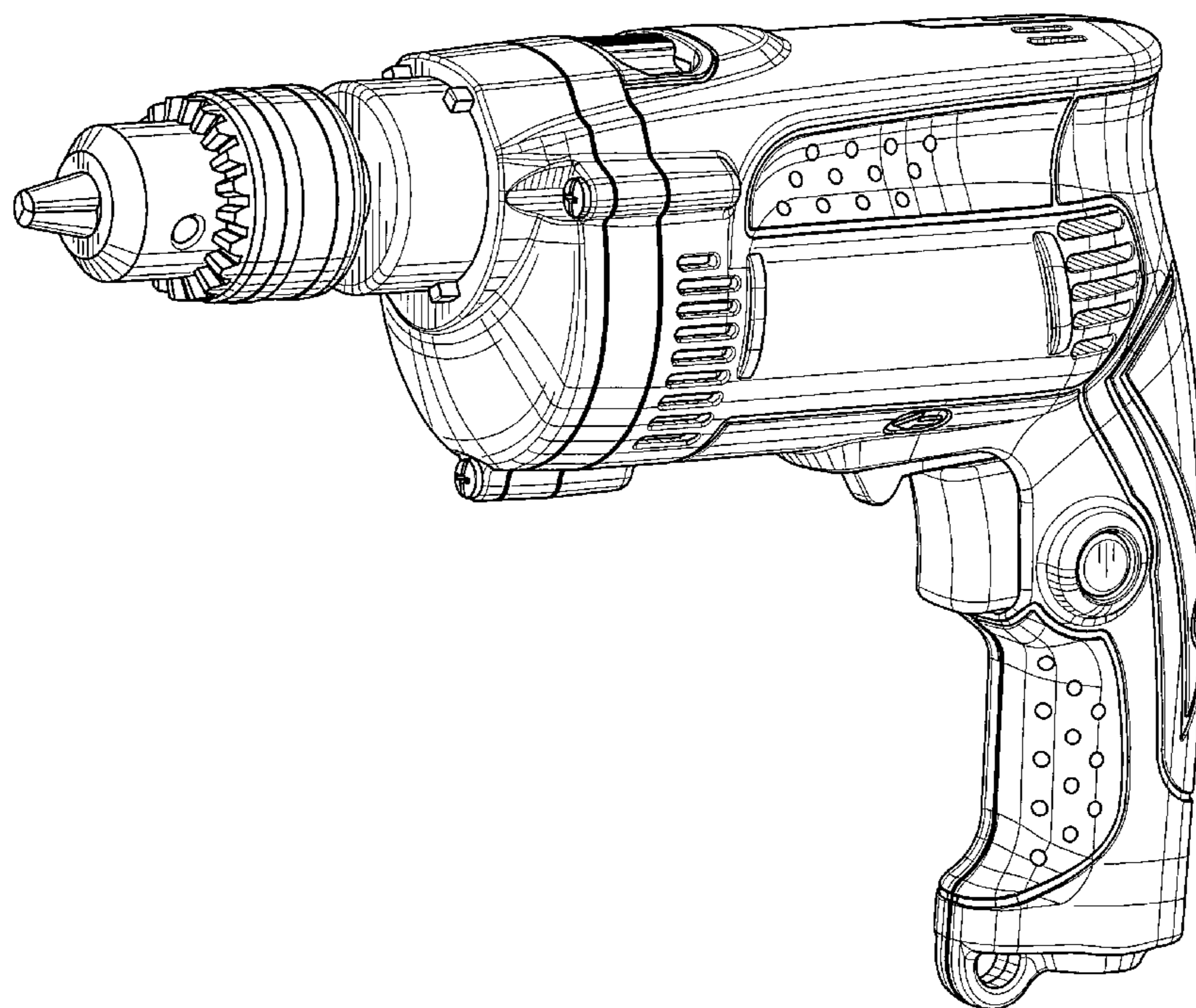

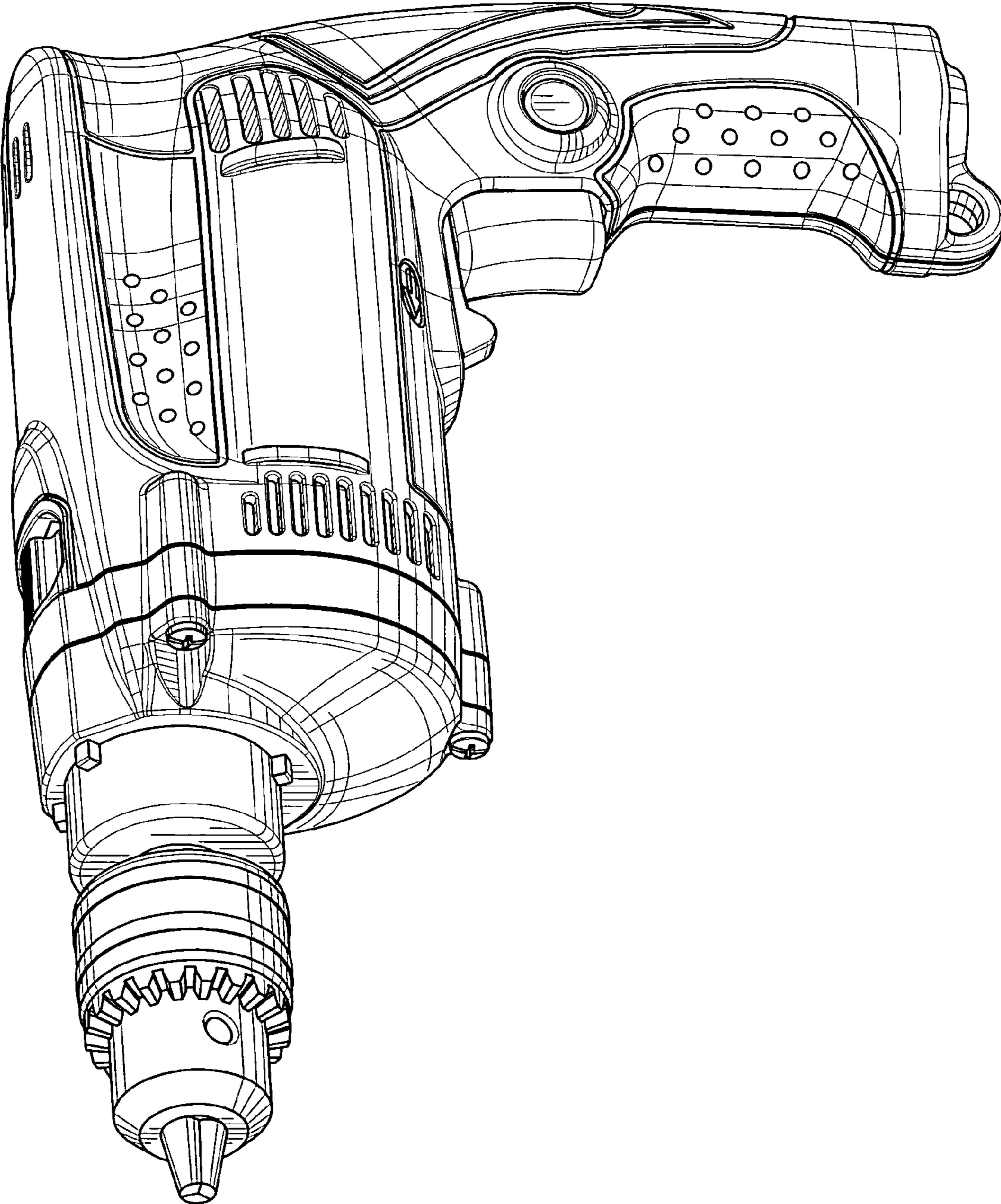

FIG. 1

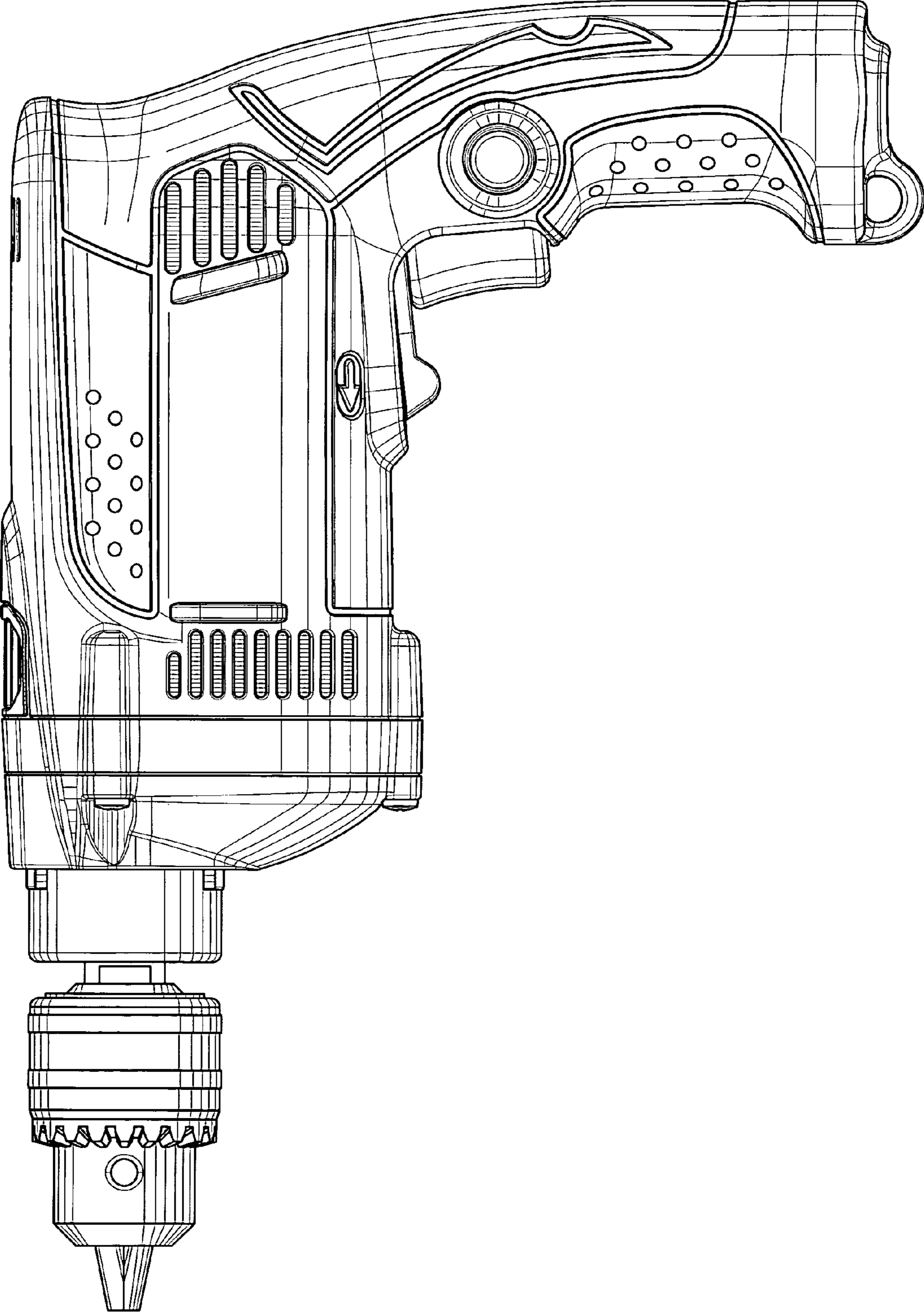

FIG. 2



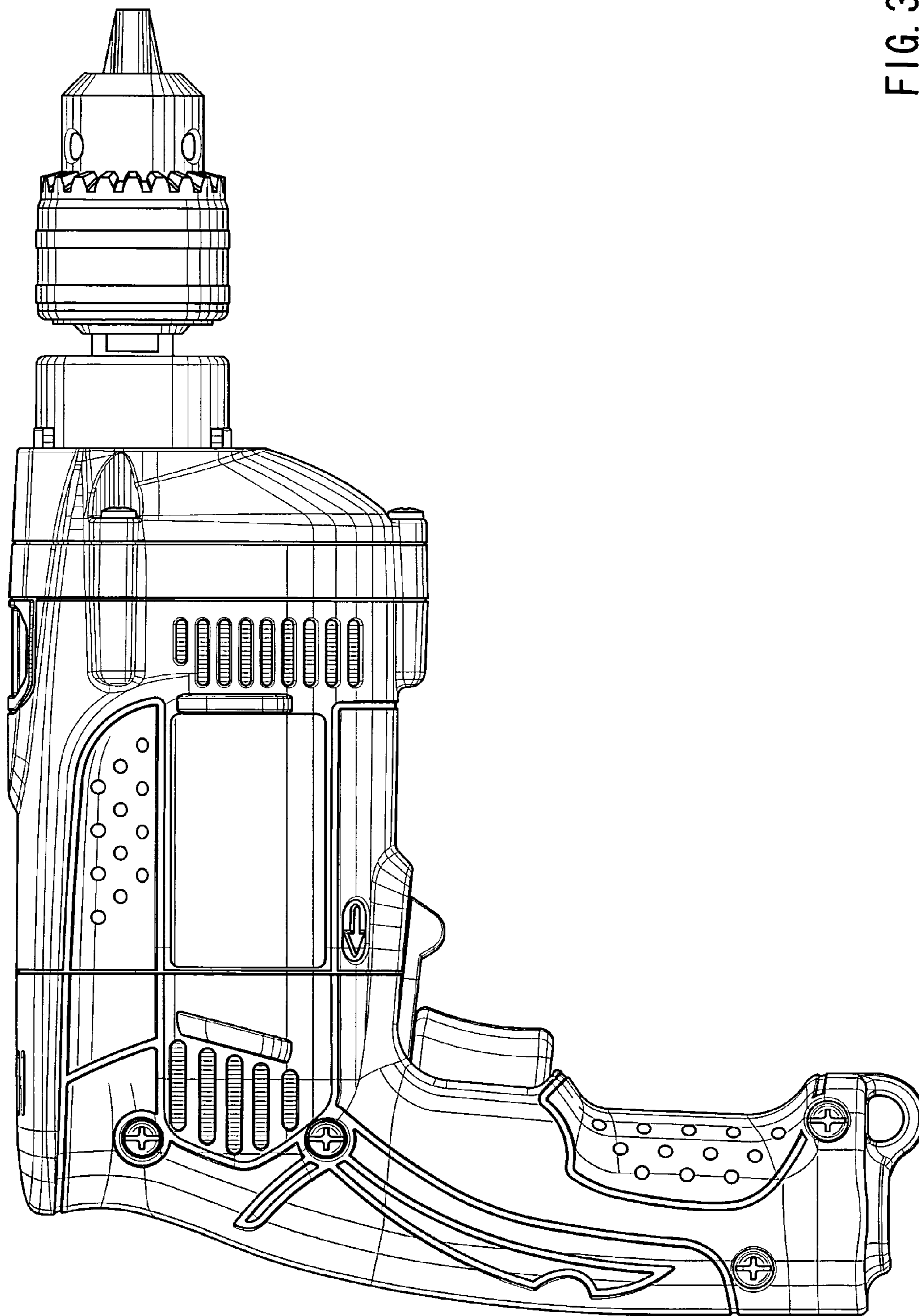

FIG. 3

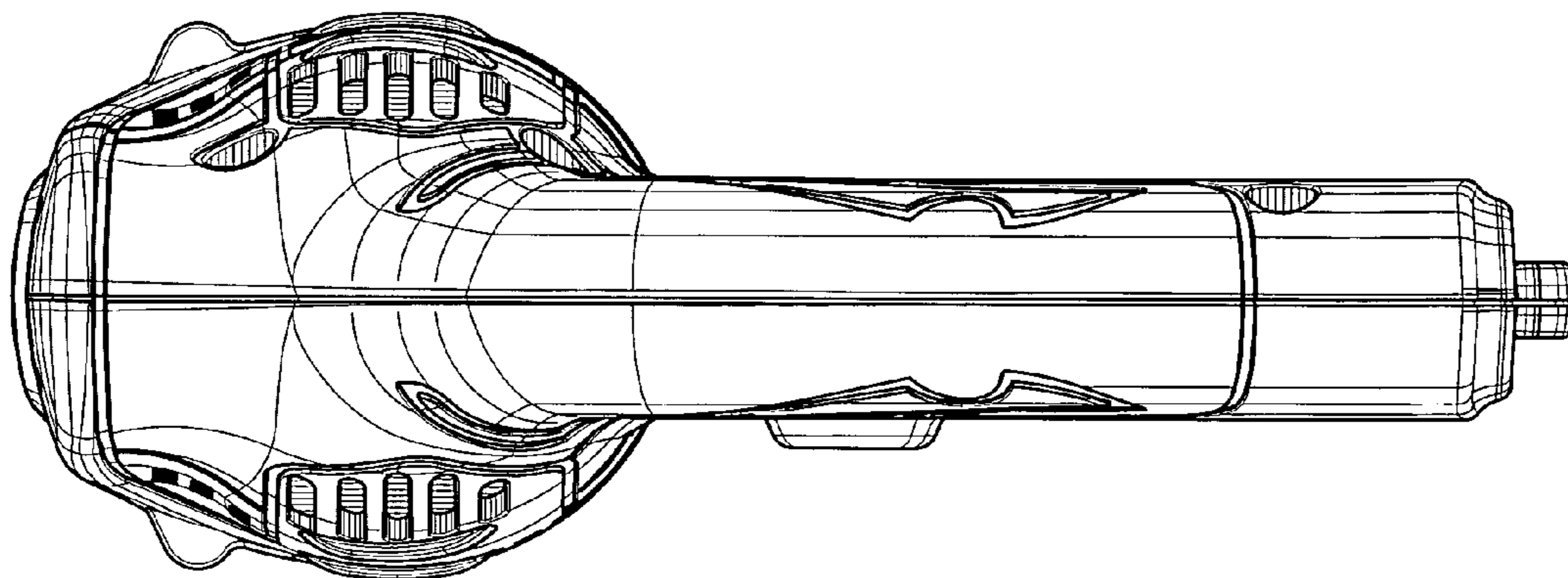

FIG. 5

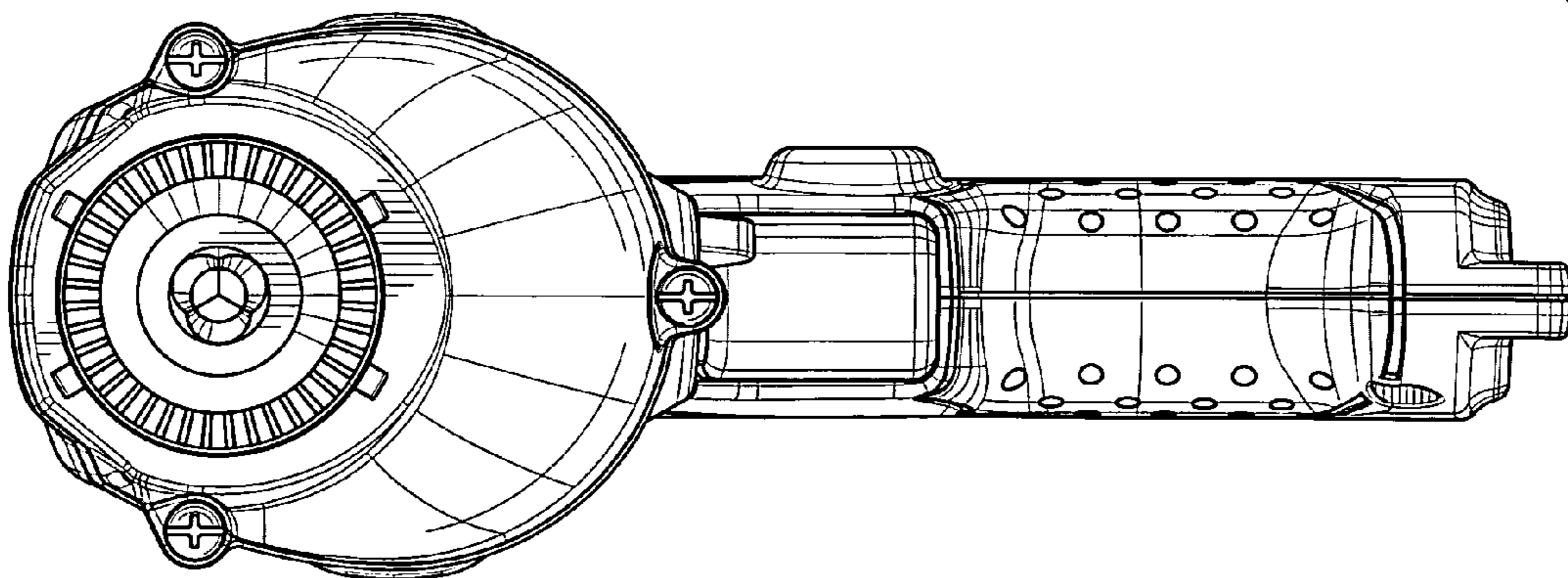

FIG. 4

FIG. 6

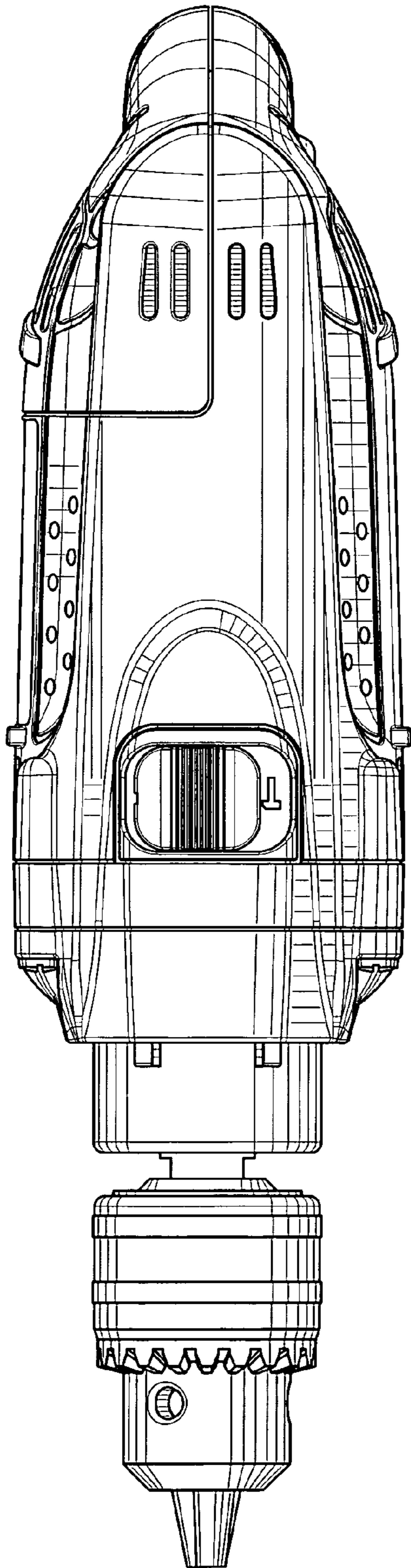

FIG. 7

