



US00D587485S

(12) **United States Design Patent**  
**Albright**

(10) **Patent No.:** **US D587,485 S**  
(45) **Date of Patent:** **\*\* Mar. 3, 2009**

(54) **LABORATORY WORK STATION**

D477,933 S \* 8/2003 Wood et al. .... D6/437  
D498,618 S \* 11/2004 Welch et al. .... D6/479

(75) Inventor: **Chip Albright**, Ooltewah, TN (US)

(73) Assignee: **Collegedale Casework, Inc.**,  
Collegedale, TN (US)

(\*\*) Term: **14 Years**

(21) Appl. No.: **29/266,589**

(22) Filed: **Sep. 25, 2006**

(51) **LOC (9) Cl.** ..... **06-04**

(52) **U.S. Cl.** ..... **D6/437**

(58) **Field of Classification Search** ..... D6/437,  
D6/396, 509, 477-479, 511; 108/80.01,  
108/180, 186, 153.1, 59-61, 91-93; 198/346.1;  
52/36.1, 182; 211/153, 183, 134, 90.4; 312/278-281  
See application file for complete search history.

(56) **References Cited**

**U.S. PATENT DOCUMENTS**

3,771,466	A *	11/1973	Ferdinand et al. ....	108/109
4,469,029	A *	9/1984	Ramond .....	108/3
4,705,327	A *	11/1987	Bollman .....	312/312
4,905,609	A *	3/1990	Haskins .....	108/23
4,941,412	A *	7/1990	Engel .....	108/156
5,148,928	A *	9/1992	Arnold .....	211/187
D379,885	S *	6/1997	Linder .....	D6/479
5,964,165	A *	10/1999	Schmidt et al. ....	108/158.11
D430,752	S *	9/2000	Hazen et al. ....	D6/437
D437,707	S *	2/2001	Fear et al. ....	D6/397
D455,916	S *	4/2002	Fluhrer et al. ....	D6/477

**OTHER PUBLICATIONS**

DPR Planners Cornell Project Specification which provides for an all metal laboratory station configuration.

\* cited by examiner

*Primary Examiner*—Caron Veynar

*Assistant Examiner*—Abraham Bahta

(74) *Attorney, Agent, or Firm*—Stephen J. Stark; Miller & Martin PLLC

(57) **CLAIM**

The ornamental design for a laboratory work station, as shown and described.

**DESCRIPTION**

FIG. 1 is a top perspective view of a laboratory work station embodying my new design;

FIG. 2 is a right side elevational view thereof; the left side being a mirror image thereof;

FIG. 3 is a front elevational view thereof; the back view being a mirror image thereof;

FIG. 4 is a top view elevational view thereof;

FIG. 5 is a bottom elevational view thereof; and,

FIG. 6 is a partial view taken from the circular broken lines shown in FIG. 1.

**1 Claim, 3 Drawing Sheets**

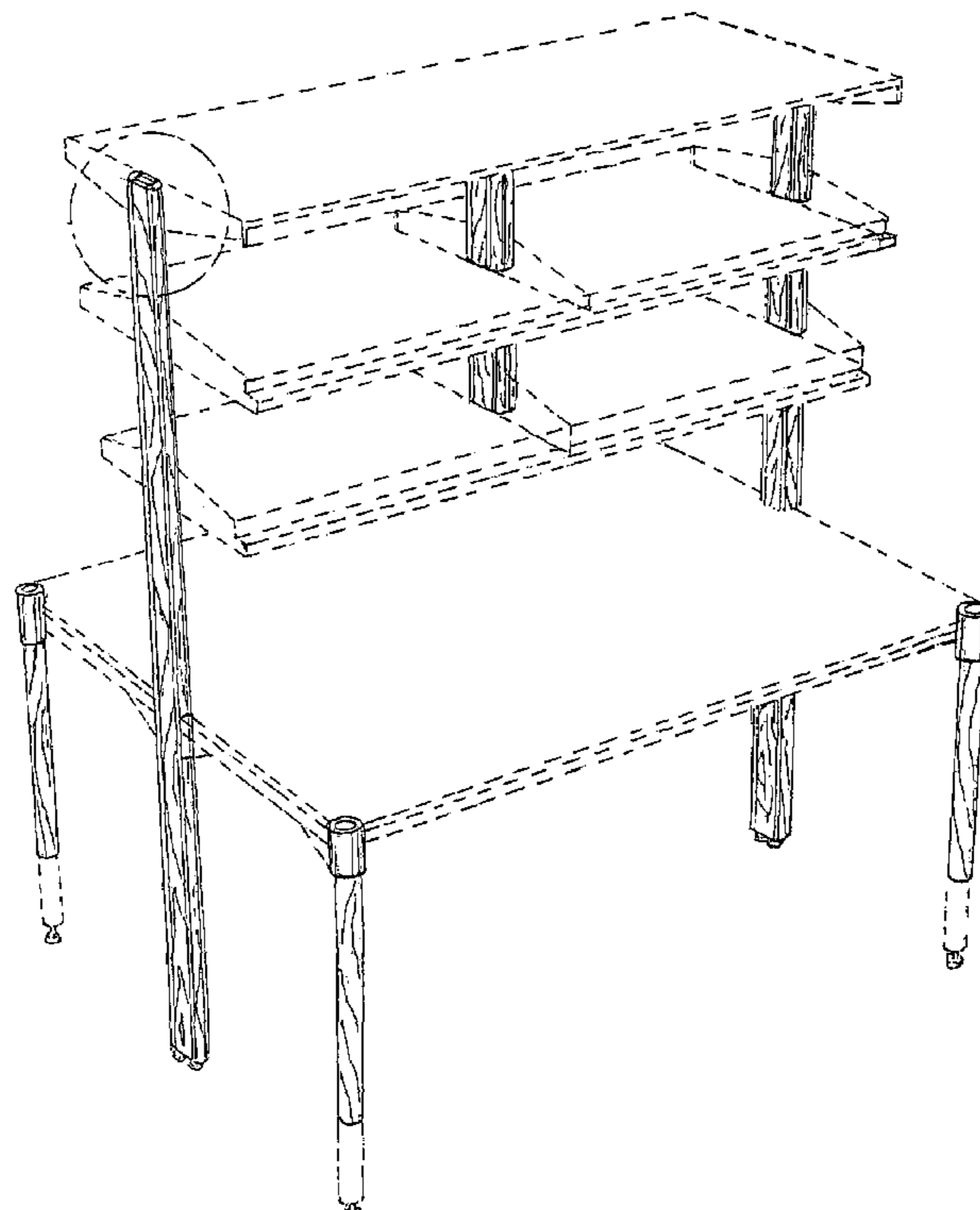

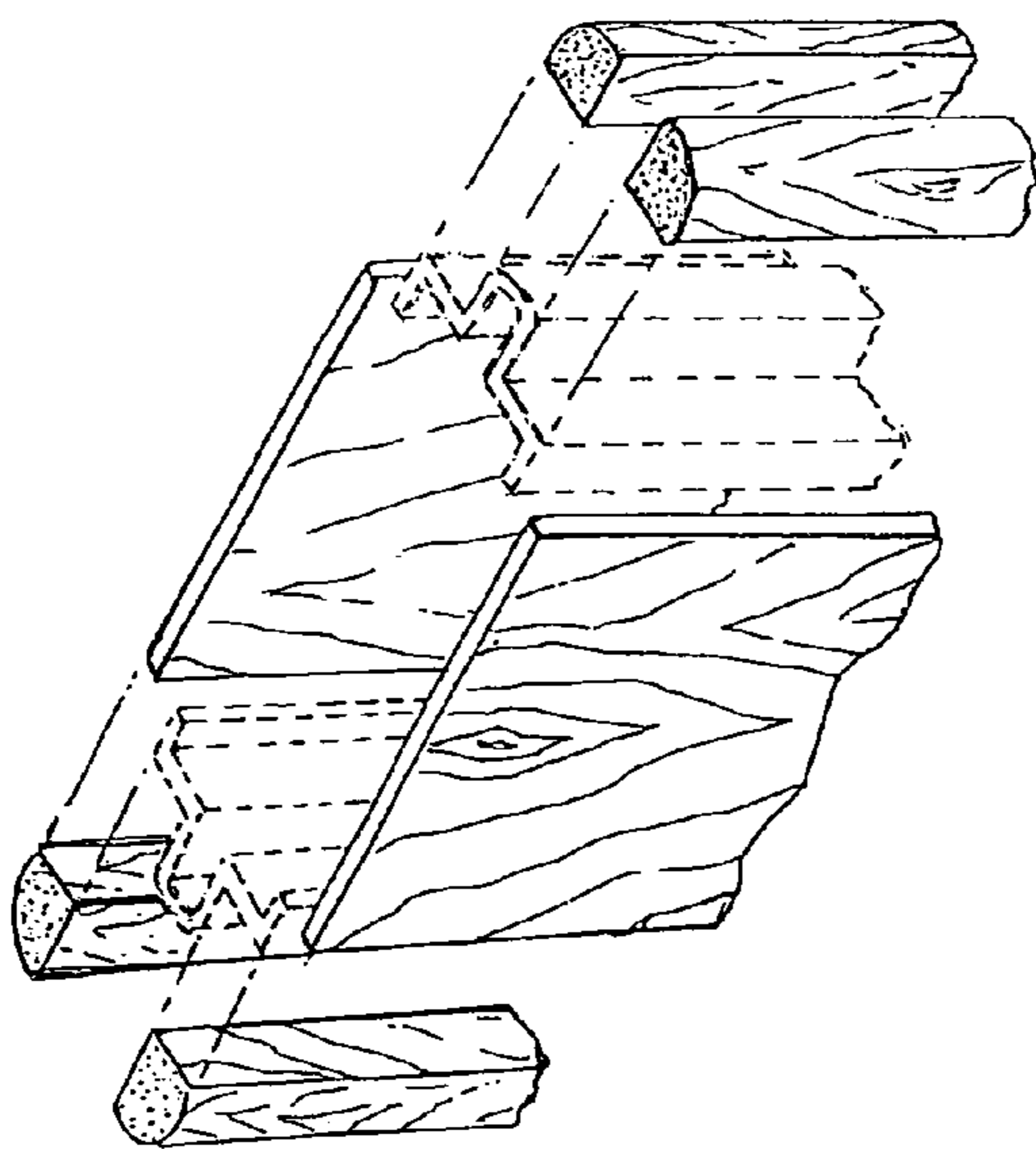
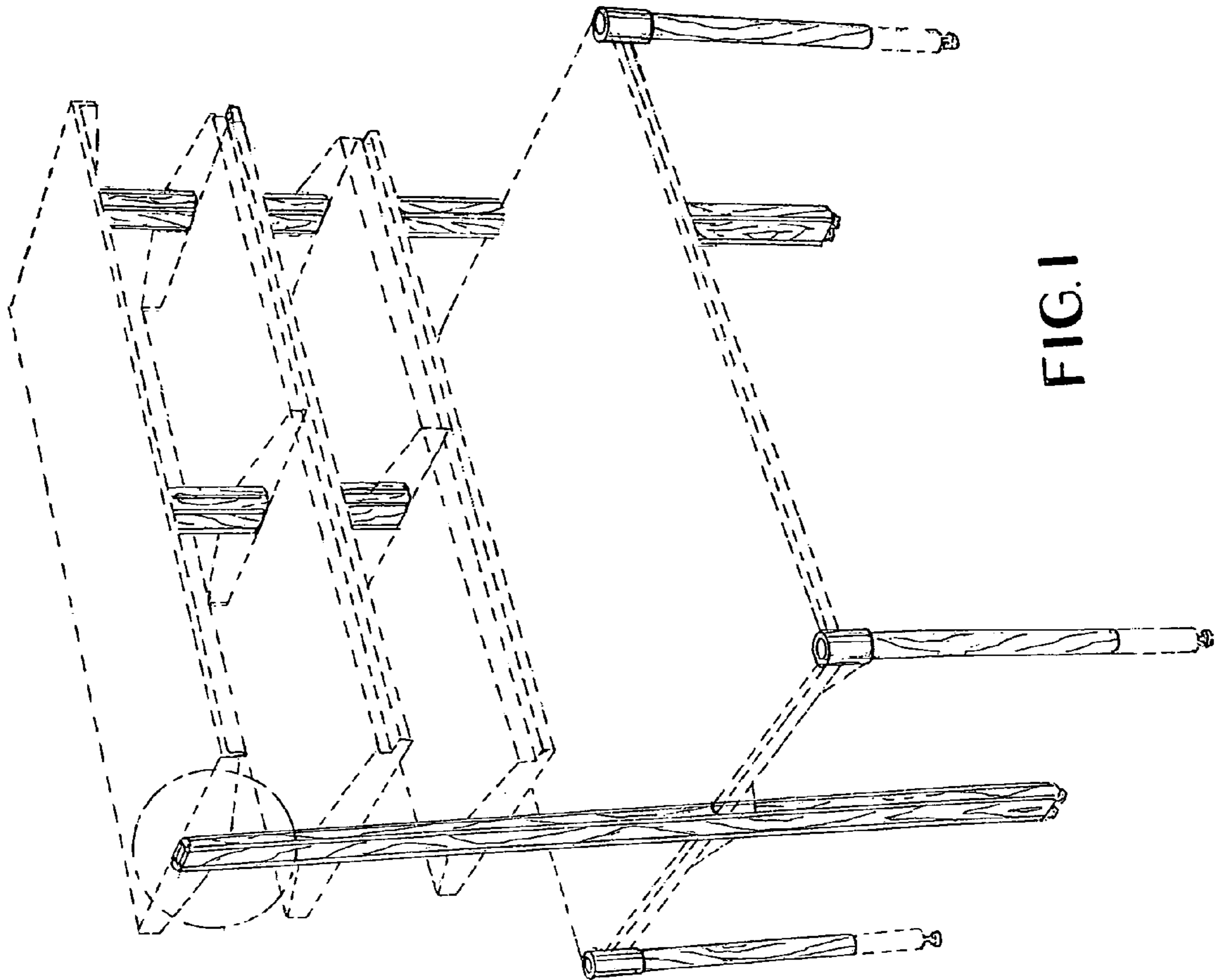

**FIG. 2**

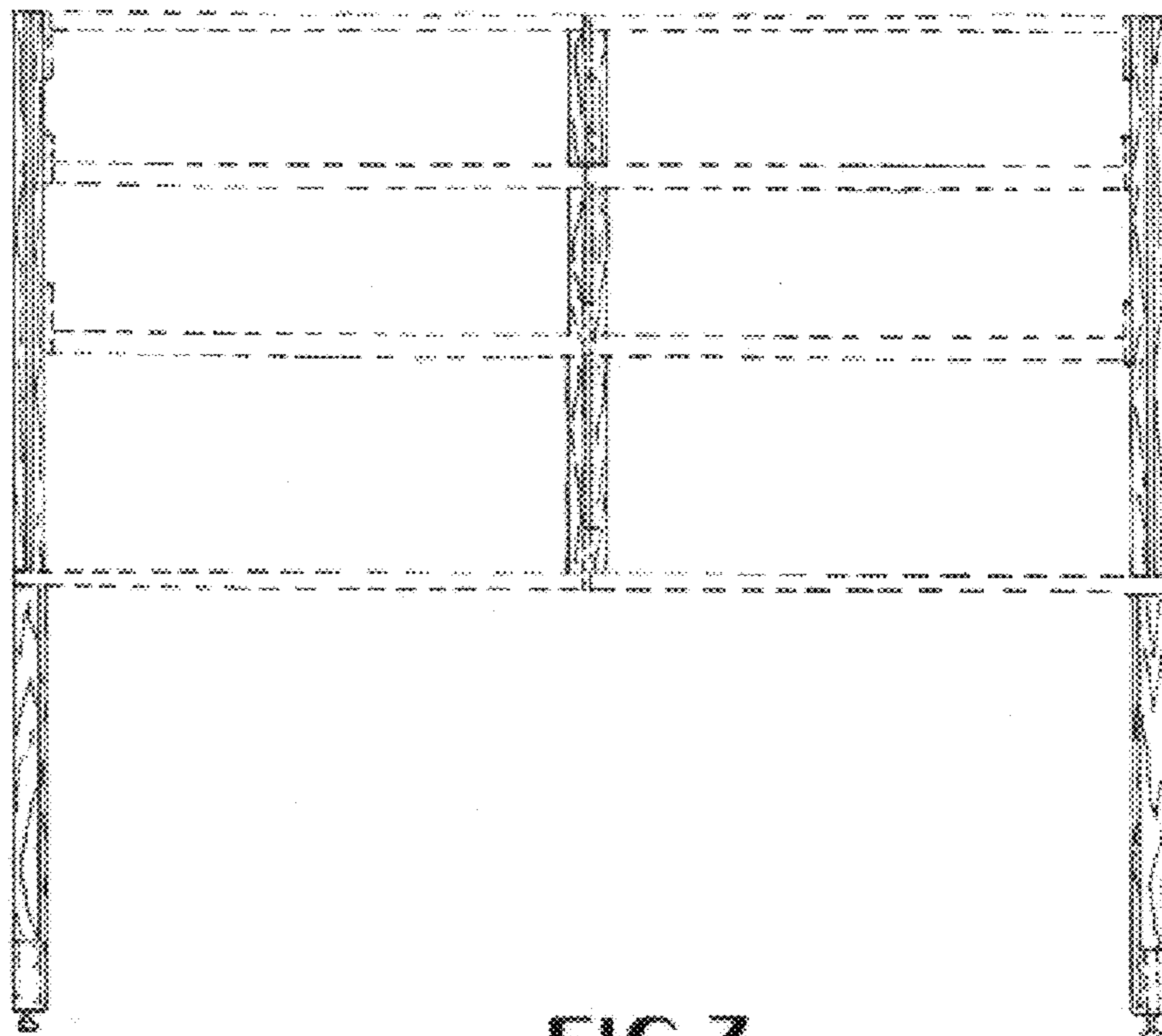
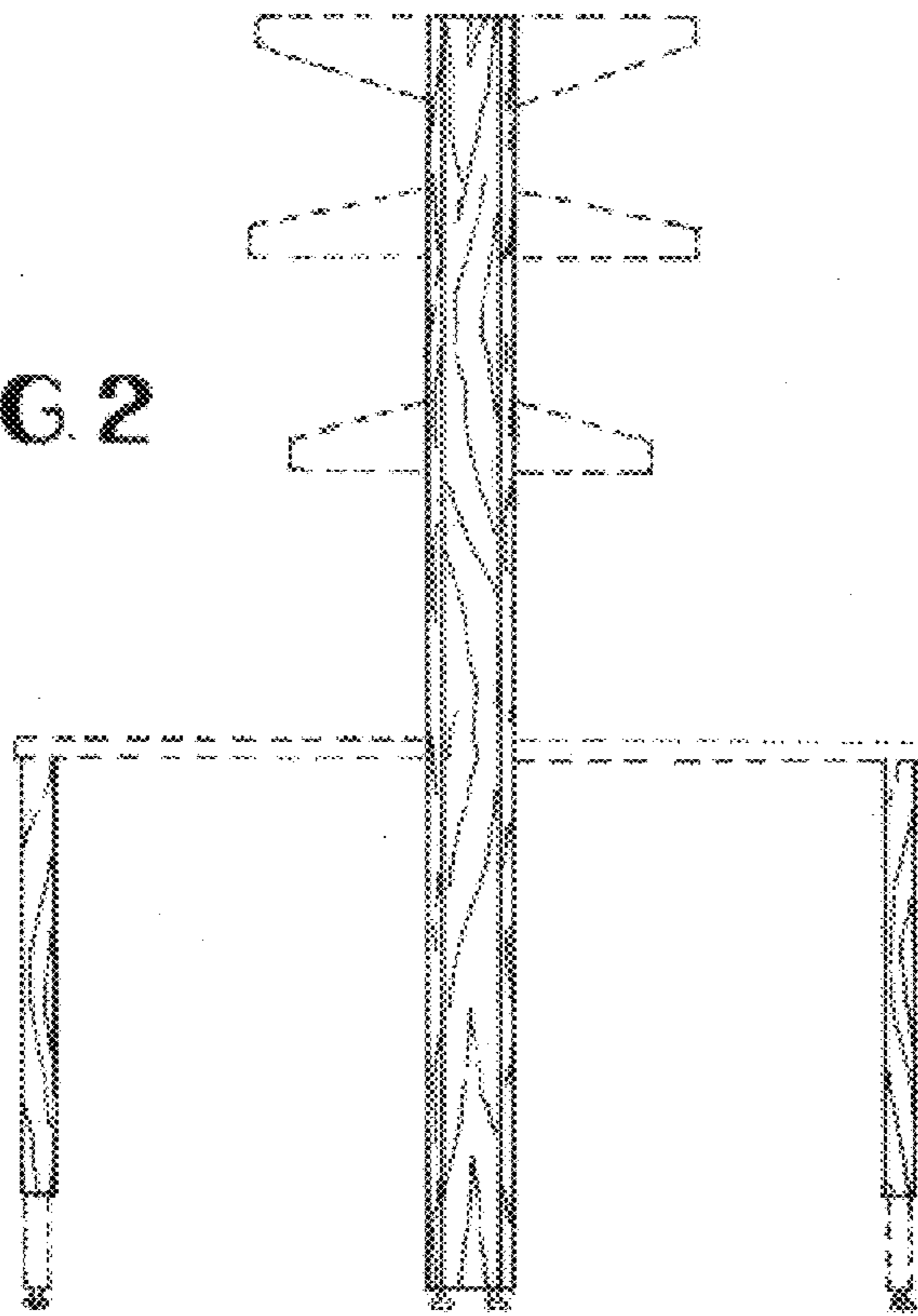

**FIG. 3**

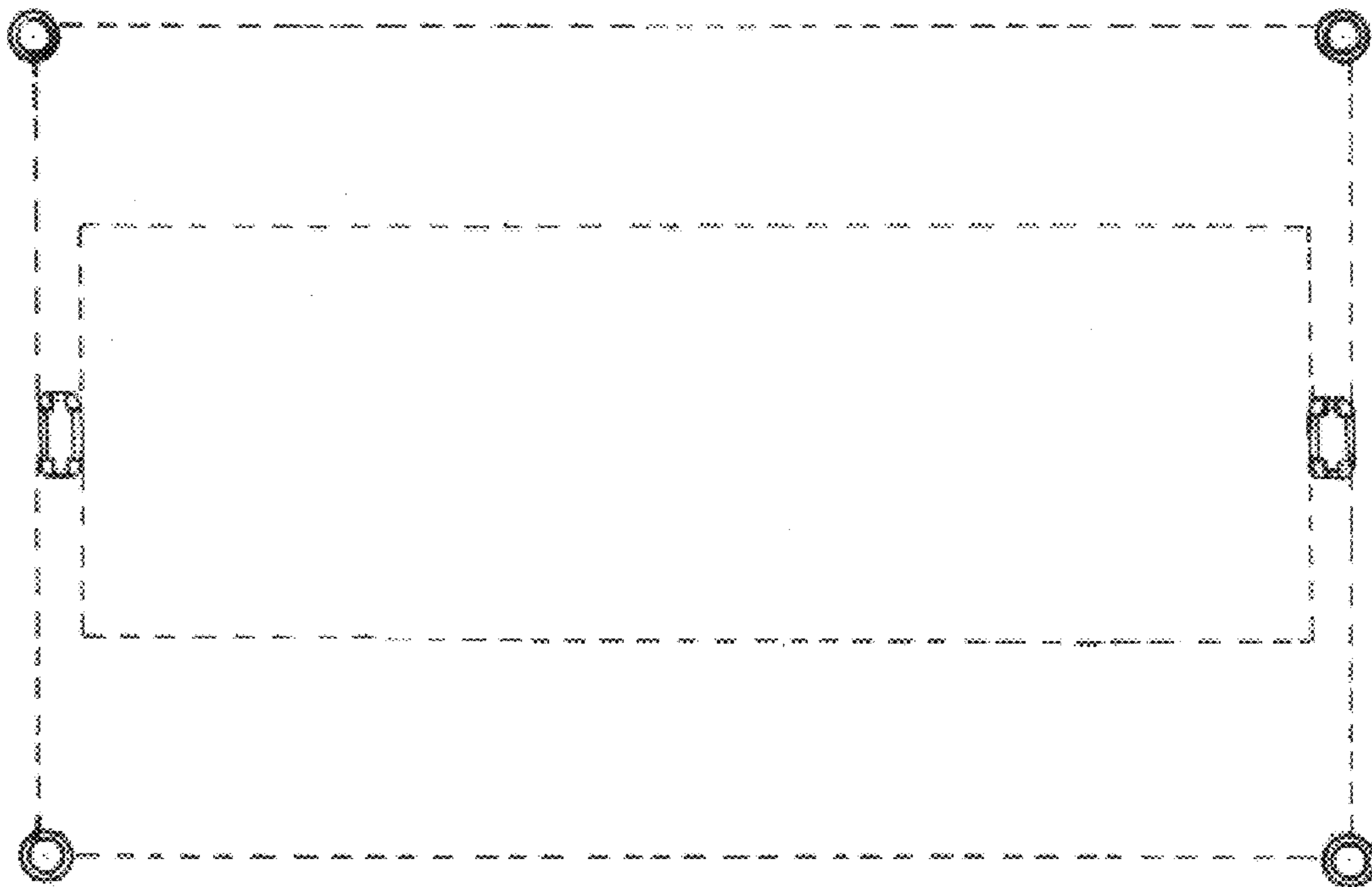

FIG. 4

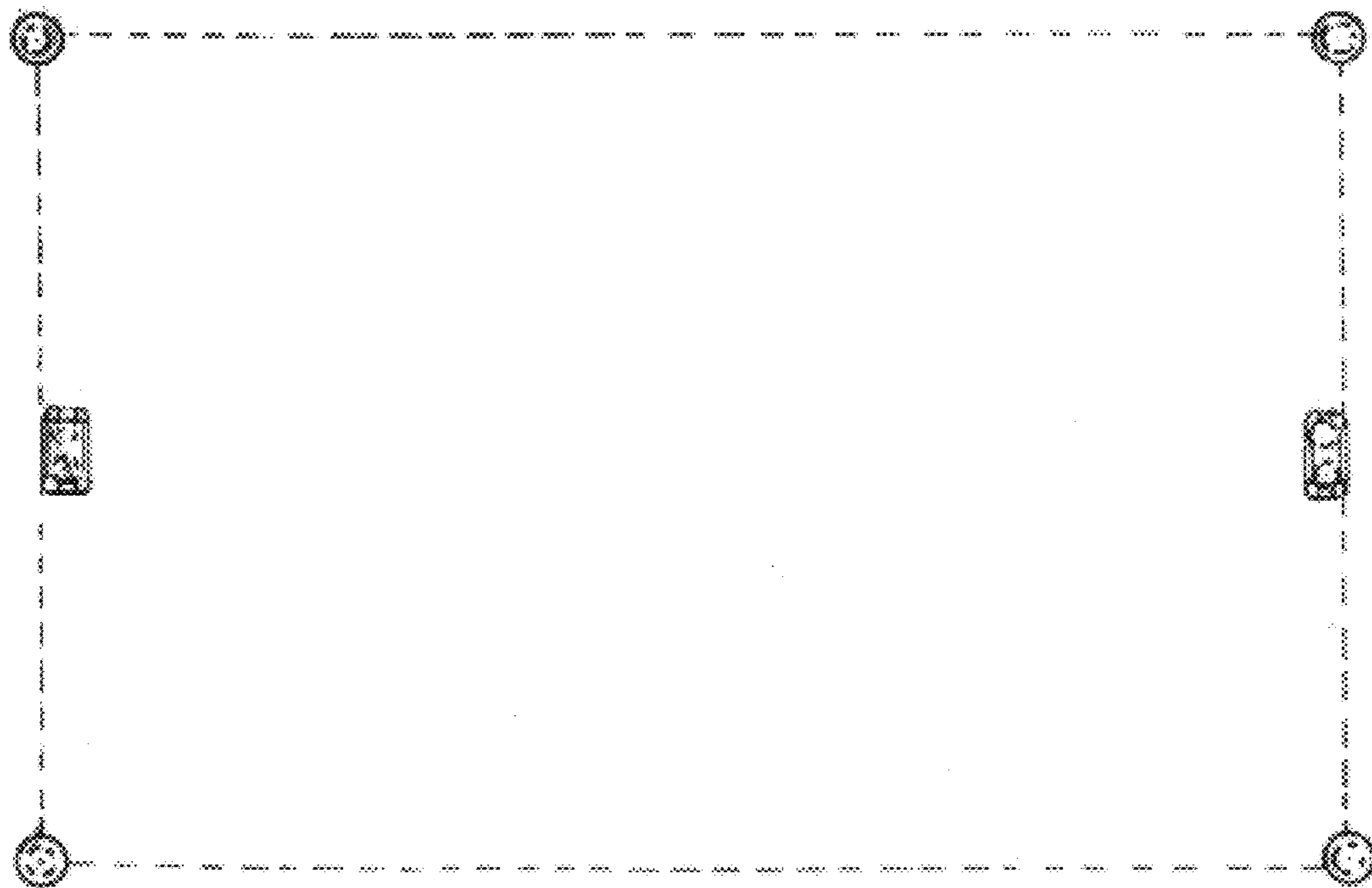

FIG. 5