



US00D587410S

(12) **United States Design Patent**
Wolner et al.

(10) **Patent No.:** **US D587,410 S**

(45) **Date of Patent:** **** Feb. 24, 2009**

(54) **SELF-RETRACTING LIFELINE HOUSING**

Photos of self retracting lifeline, *DB Industries, Inc.*, 2 pages (offered for sale in Japan in 2005).

(75) Inventors: **J. Thomas Wolner**, Red Wing, MN (US); **James Theodore Tuck, Jr.**, Red Wing, MN (US)

* cited by examiner

(73) Assignee: **DB Industries, Inc.**, Red Wing, MN (US)

Primary Examiner—Raphael Barkai

Assistant Examiner—Randall H Gholson

(74) *Attorney, Agent, or Firm*—IPLM Group, P.A.

(**) Term: **14 Years**

(57) **CLAIM**

(21) Appl. No.: **29/282,323**

The ornamental design for self-retracting lifeline housing, as shown and described.

(22) Filed: **Jul. 17, 2007**

(51) **LOC (9) Cl.** **29-02**

(52) **U.S. Cl.** **D29/124**

(58) **Field of Classification Search** D29/124;
441/80, 83-85; 182/3, 4, 6, 7, 9, 189, 193;
188/65.4, 65.5, 65.1; 294/19.1, 17, 24, 26;
D6/347; D21/823, 825, 828, 831; 472/75,
472/78, 80, 118, 121, 133; 297/273, 259.3

See application file for complete search history.

DESCRIPTION

FIG. 1 is a front view of a self-retracting lifeline housing;

FIG. 2 is a rear view of the self-retracting lifeline housing shown in FIG. 1;

FIG. 3 is a top view of the self-retracting lifeline housing shown in FIG. 1;

FIG. 4 is a bottom view of the self-retracting lifeline housing shown in FIG. 1;

FIG. 5 is a left side view of the self-retracting lifeline housing shown in FIG. 1;

FIG. 6 is a right side view of the self-retracting lifeline housing shown in FIG. 1; and,

FIG. 7 is a perspective view of the self-retracting lifeline housing shown in FIG. 1.

(56) **References Cited**

U.S. PATENT DOCUMENTS

- 2,990,131 A * 6/1961 Carlsson 242/381.5
- 4,480,716 A * 11/1984 Soubry et al. 182/233
- 4,877,110 A * 10/1989 Wolner 182/232
- D377,447 S * 1/1997 Blye D8/358
- D468,189 S * 1/2003 Kovacik et al. D8/358
- D490,575 S * 5/2004 Henson D29/124

OTHER PUBLICATIONS

Self-retracting lifeline product specification sheet, *Titan Safety Belt*, Japan, 1 page (2001).

1 Claim, 5 Drawing Sheets

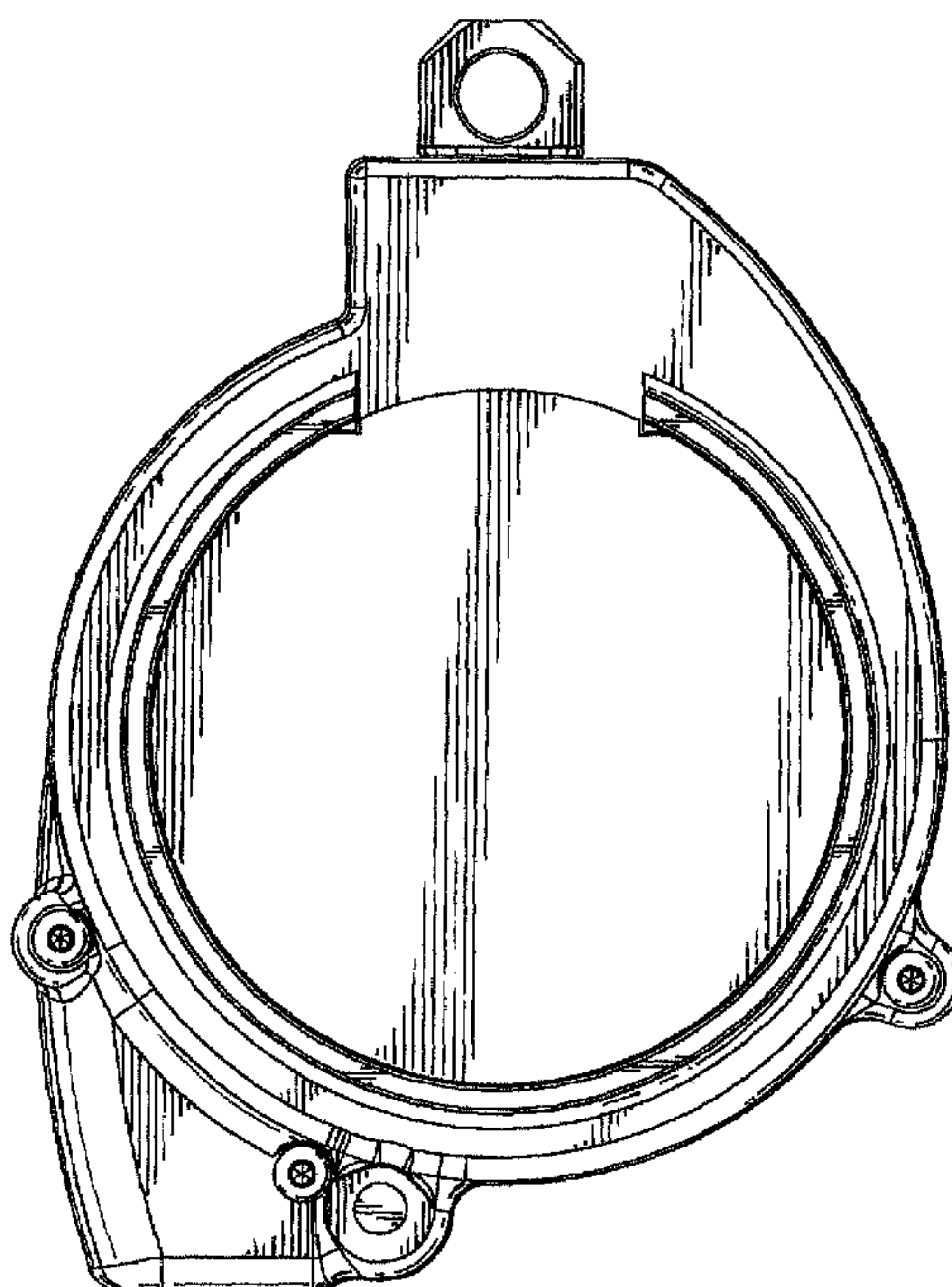

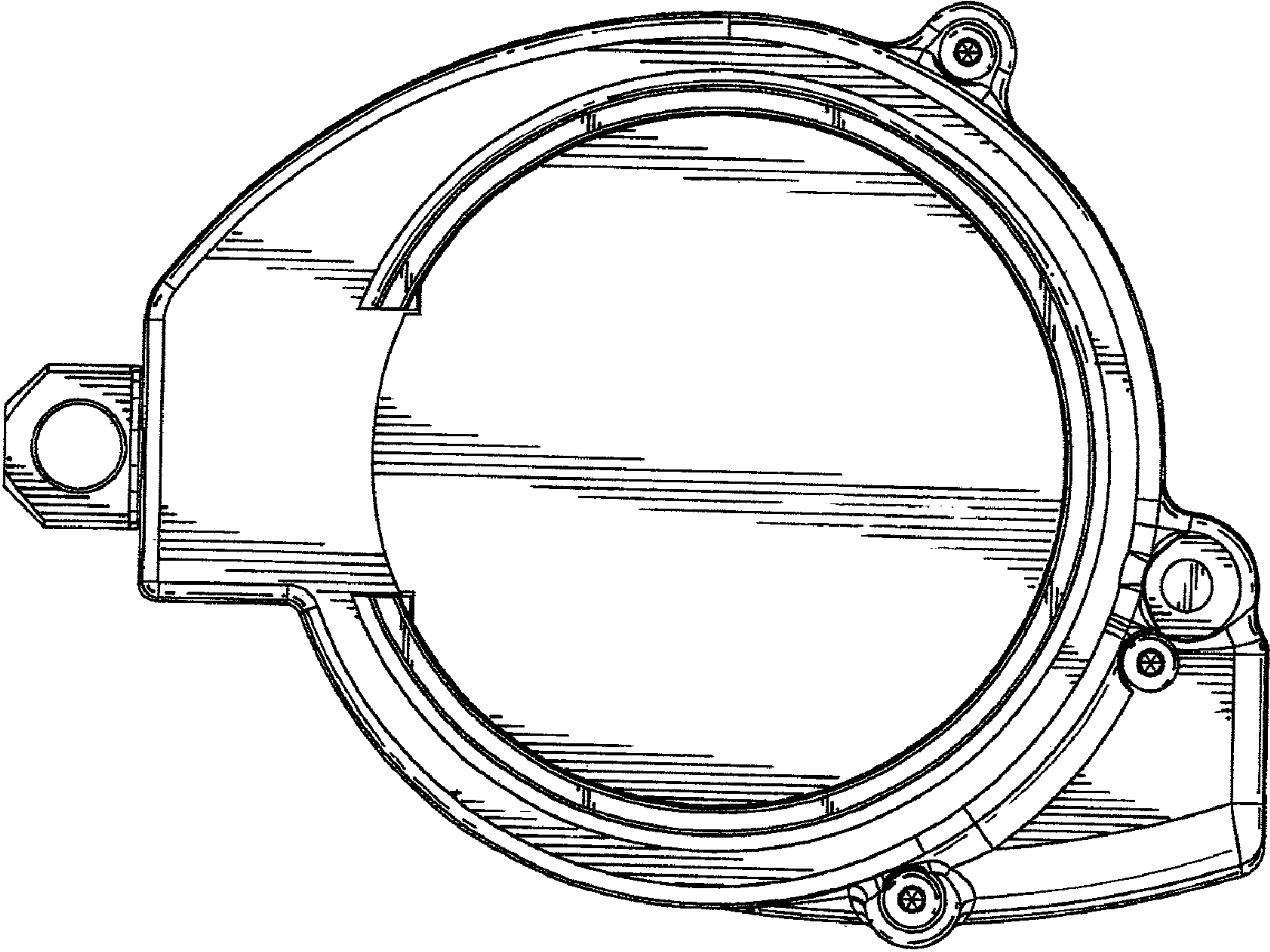

FIG. 1

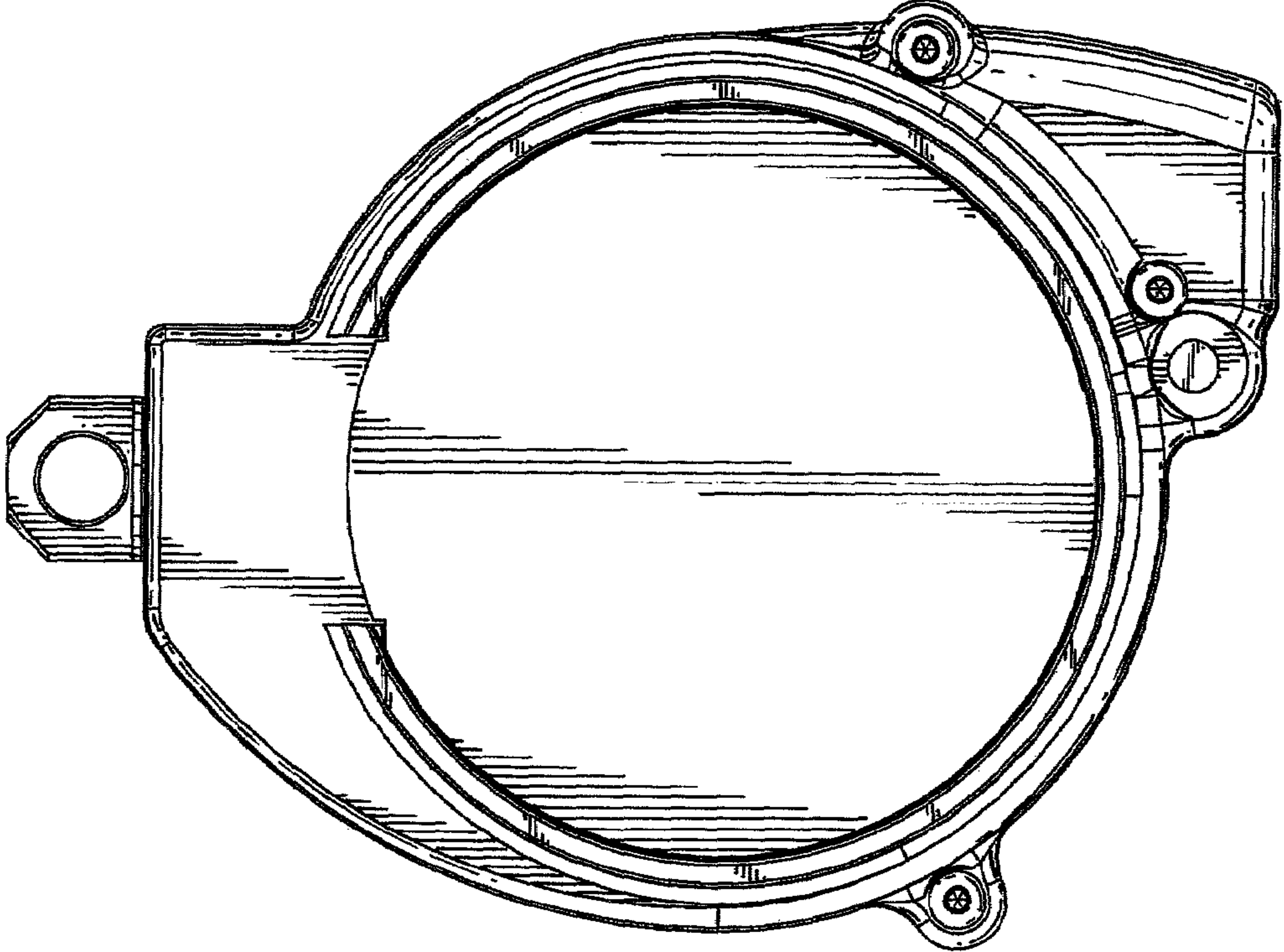

FIG. 2

FIG. 3

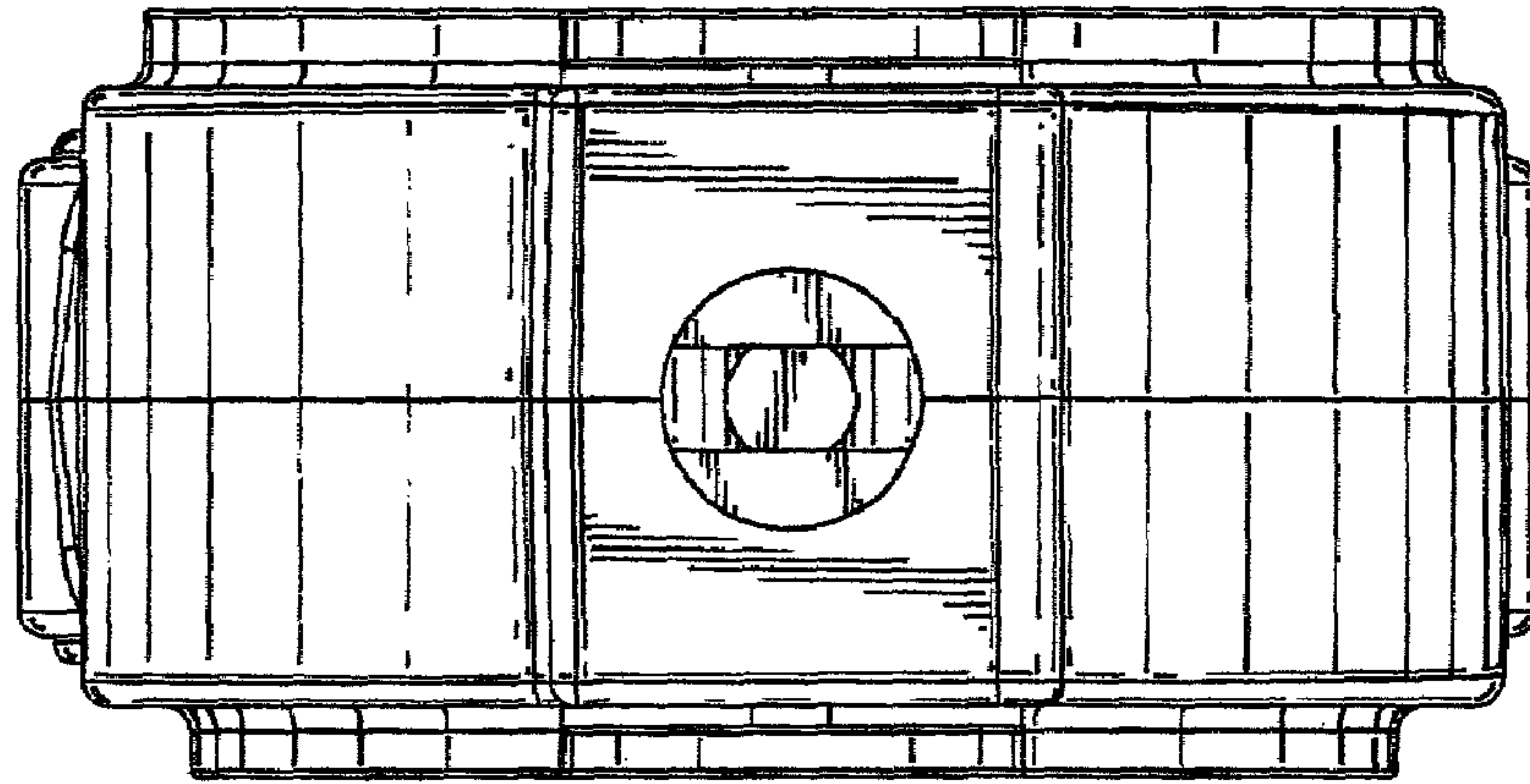

FIG. 4

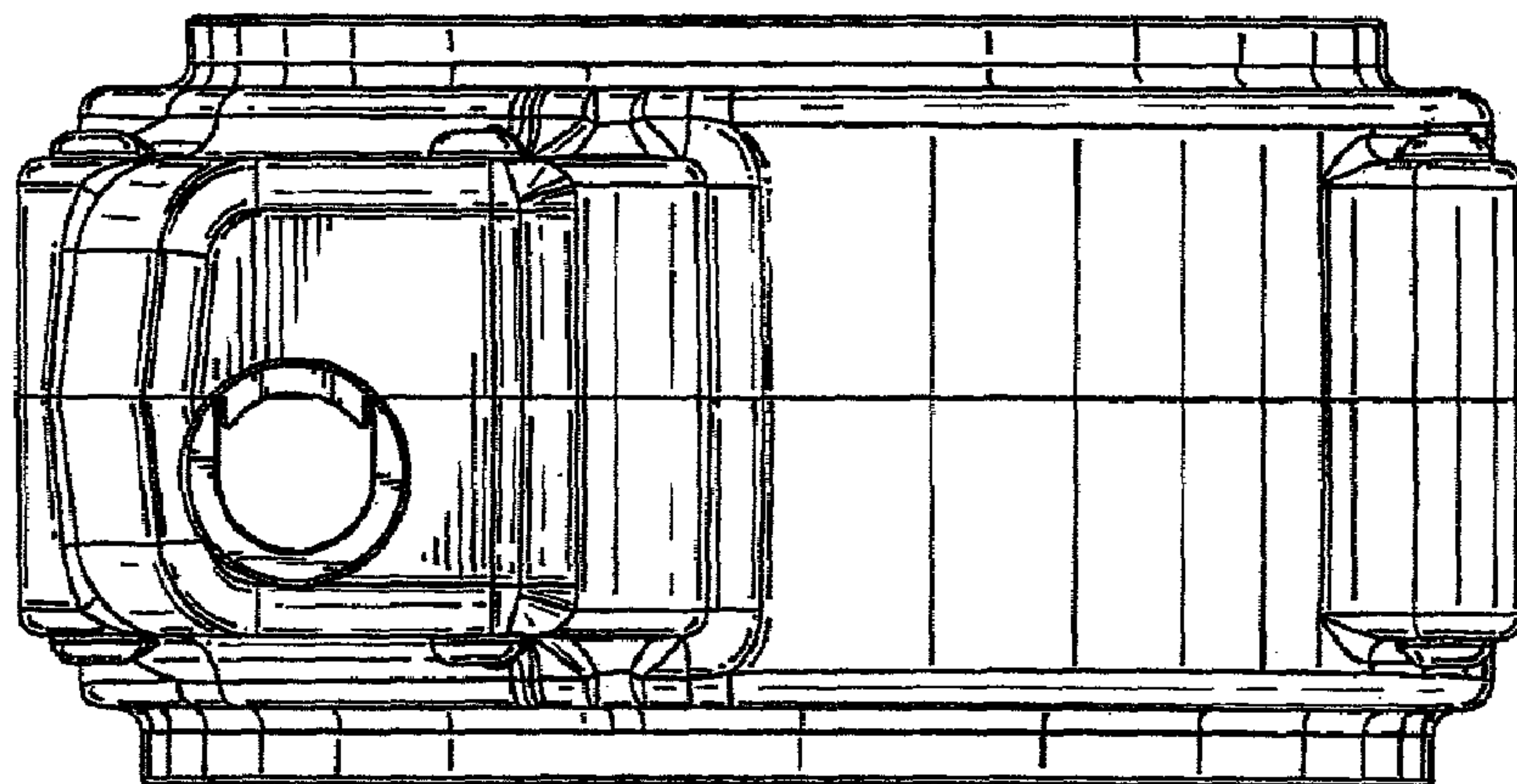

FIG. 6

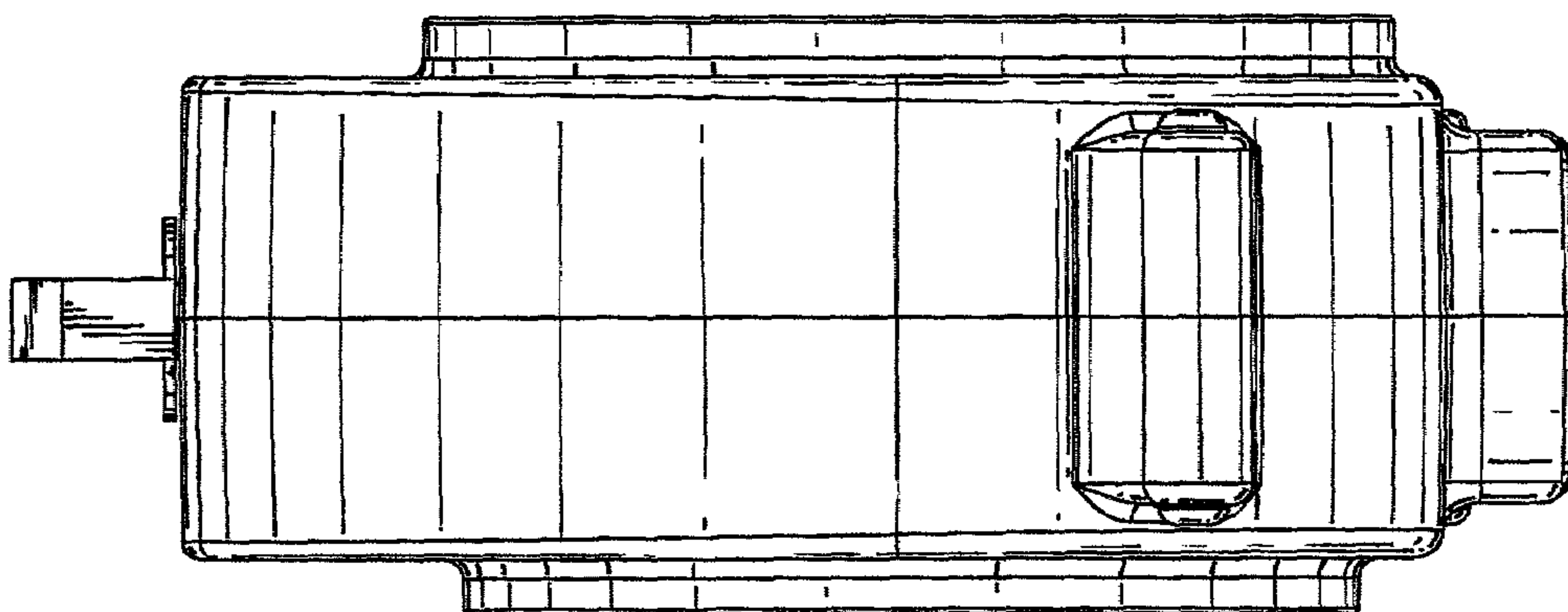
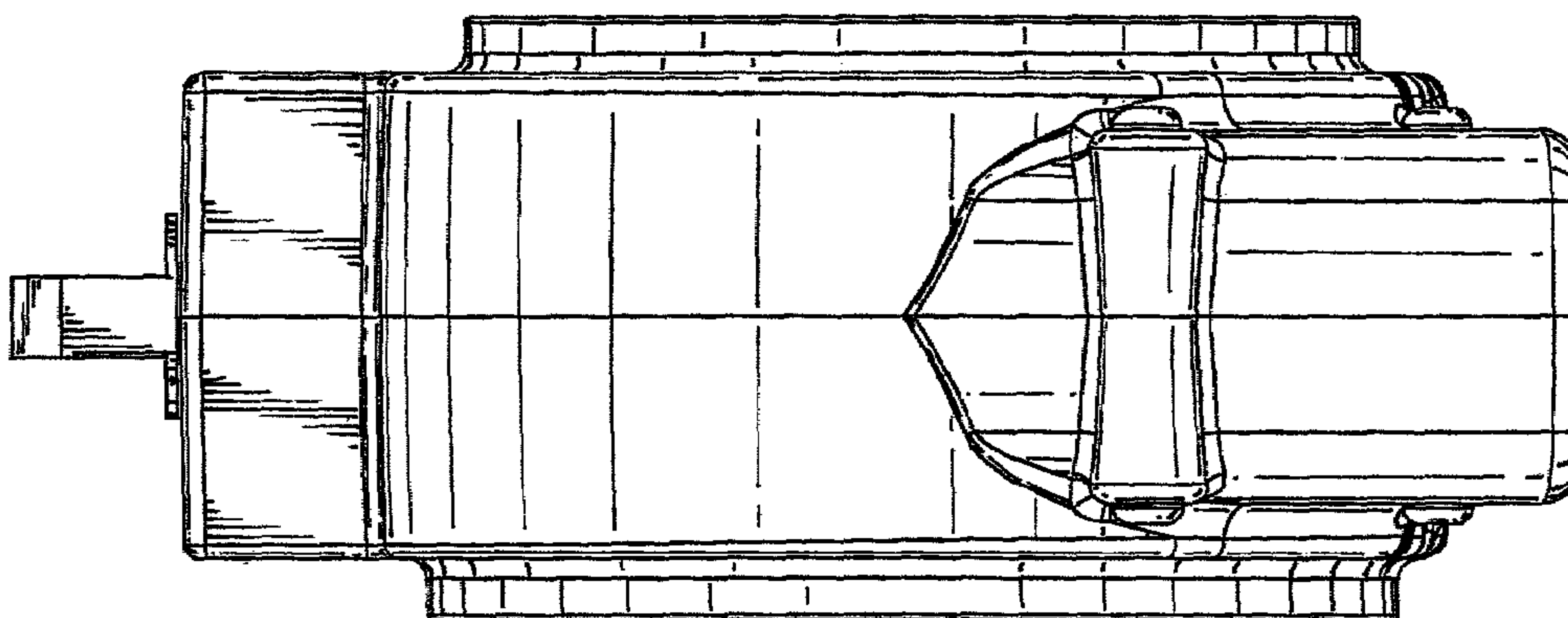

FIG. 5



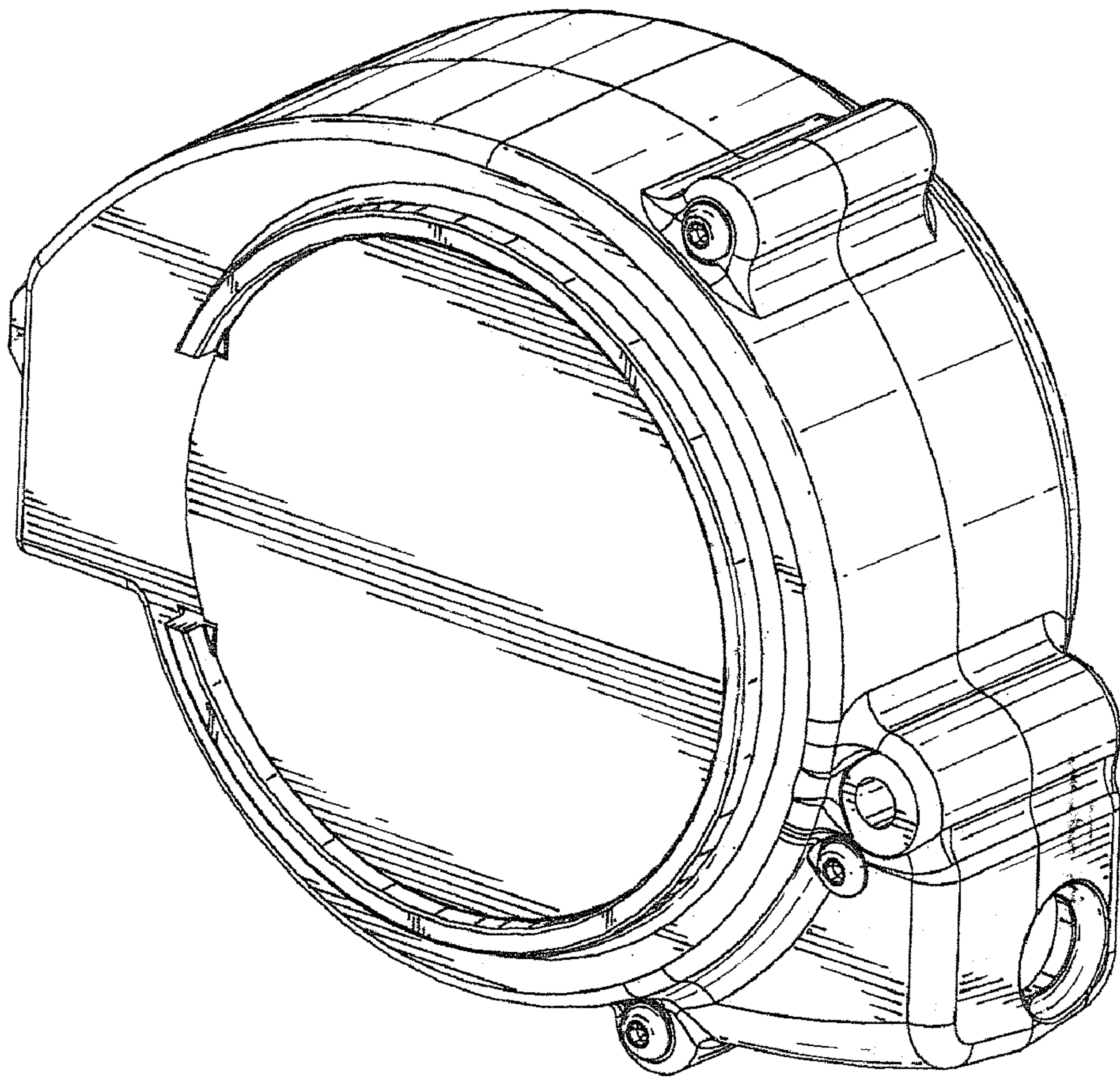

FIG. 7