



US00D587152S

(12) **United States Design Patent**
Scholpp

(10) **Patent No.:** **US D587,152 S**
(45) **Date of Patent:** **** Feb. 24, 2009**

(54) **SCALE**

(75) Inventor: **Werner Scholpp**, Oberriexingen (DE)

(73) Assignee: **SECA AG**, Reinbach (CH)

(**) Term: **14 Years**

(21) Appl. No.: **29/300,549**

(22) Filed: **Apr. 8, 2008**

(30) **Foreign Application Priority Data**

Nov. 13, 2007 (EM) 000825567

(51) **LOC (9) Cl.** **10-04**

(52) **U.S. Cl.** **D10/92**

(58) **Field of Classification Search** D10/92,
D10/93; 177/4, 25.12–25.16, 177, 199, 210 R,
177/238–245, DIG. 3, 262, 210 C, 30, 126–127;
324/692, 512, 515, 806; 600/506, 547
See application file for complete search history.

(56) **References Cited**

U.S. PATENT DOCUMENTS

D425,807 S * 5/2000 Sato D10/92
6,516,221 B1 * 2/2003 Hirouchi et al. 600/547
6,665,561 B2 * 12/2003 Baba et al. 600/547

D503,899 S * 4/2005 Yamada et al. D10/92
D523,366 S * 6/2006 Ulrich D10/92
D525,547 S * 7/2006 Yamada et al. D10/92
D531,535 S * 11/2006 Yamada et al. D10/92
D532,329 S * 11/2006 Yamada et al. D10/92
7,256,357 B1 * 8/2007 Kesselman 177/25.15
D552,499 S * 10/2007 Ashida et al D10/92

* cited by examiner

Primary Examiner—Antoine D Davis

(74) *Attorney, Agent, or Firm*—Nixon & Vanderhye, P.C.

(57) **CLAIM**

The ornamental design for a “scale,” as shown and described.

DESCRIPTION

FIG. 1 is a perspective view of a new scale design in accordance with my invention;

FIG. 2 is a left side elevation view thereof;

FIG. 3 is a top plan view thereof;

FIG. 4 is a bottom plan view thereof;

FIG. 5 is a left side elevation view thereof;

FIG. 6 is a front elevation view thereof; and,

FIG. 7 is a rear elevation view thereof.

1 Claim, 6 Drawing Sheets

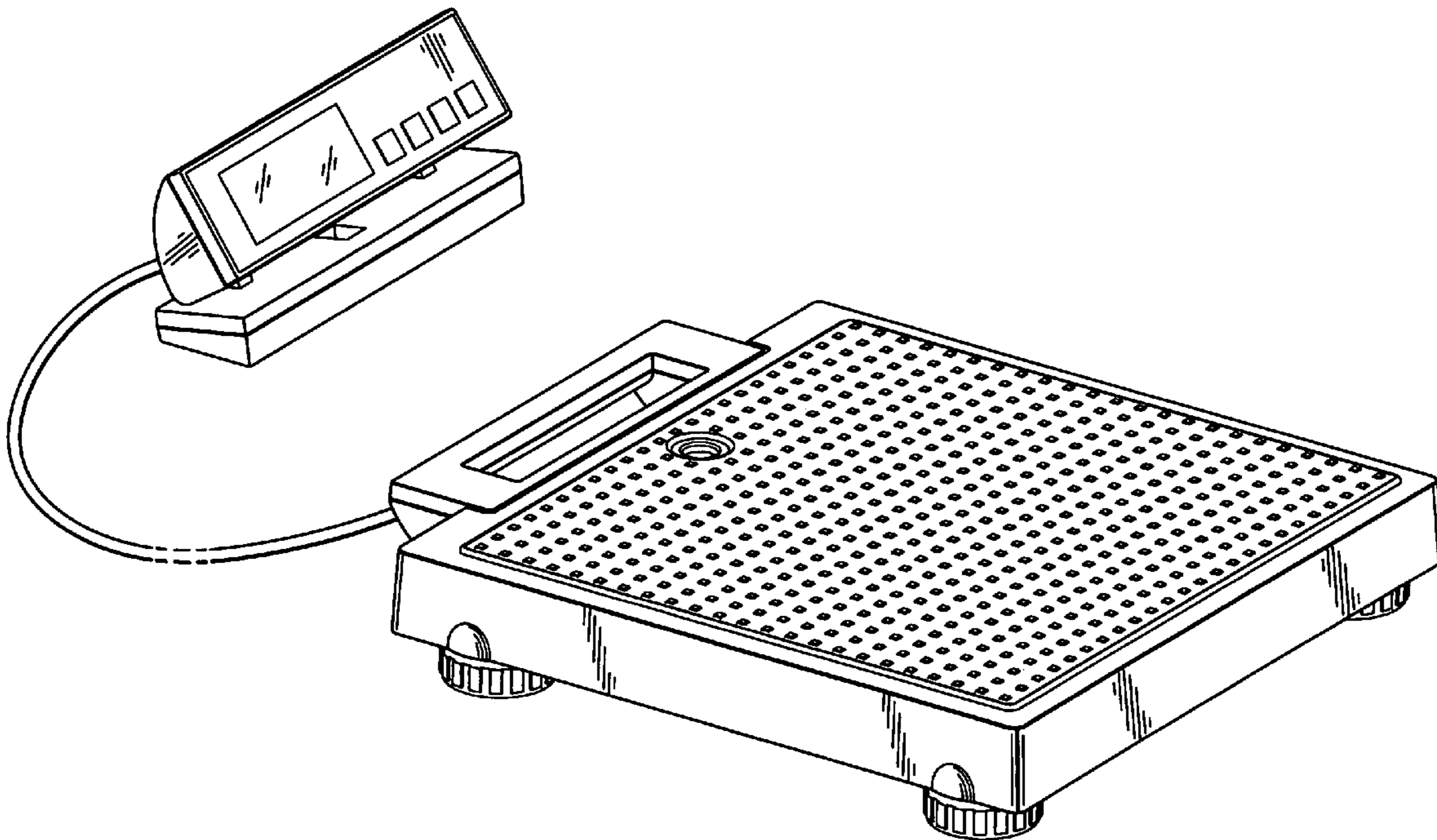

Fig. 1

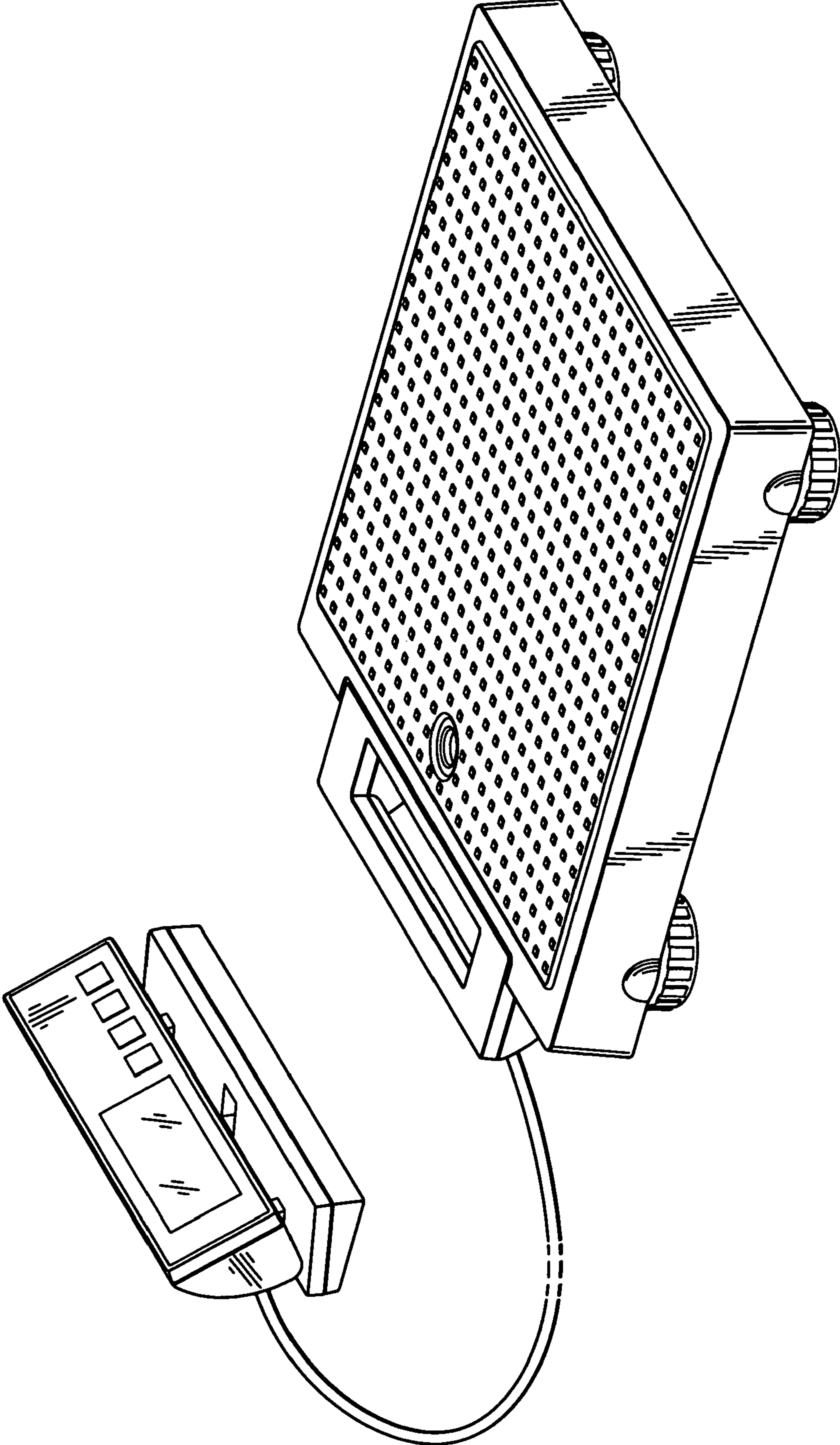

FIG. 2

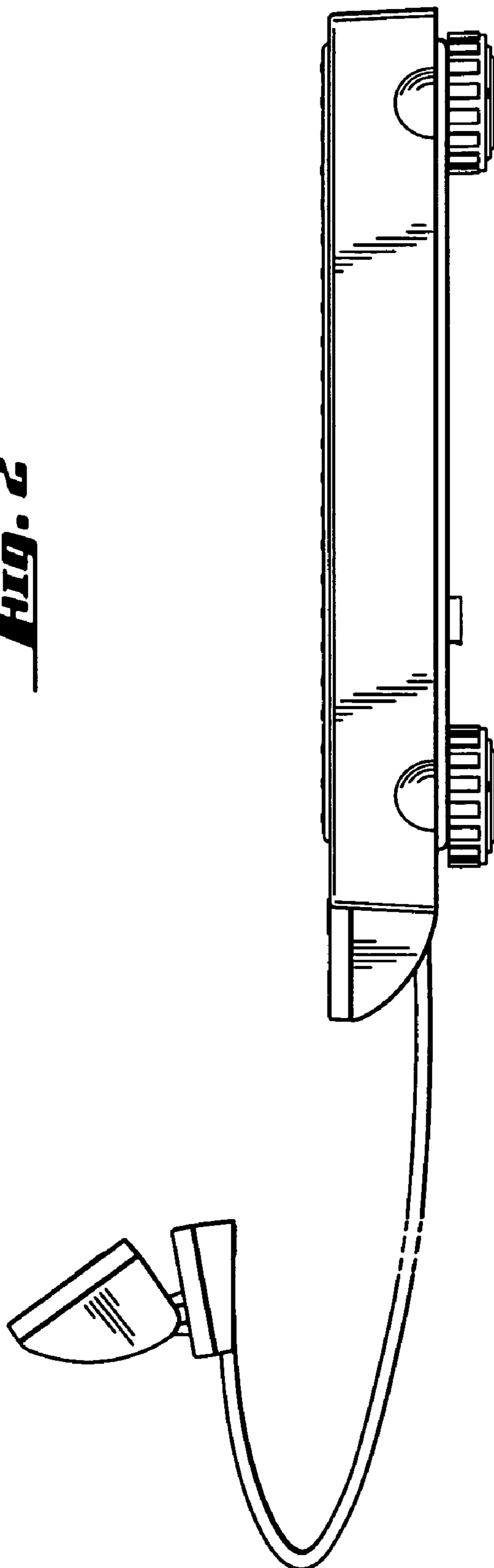

Fig. 3

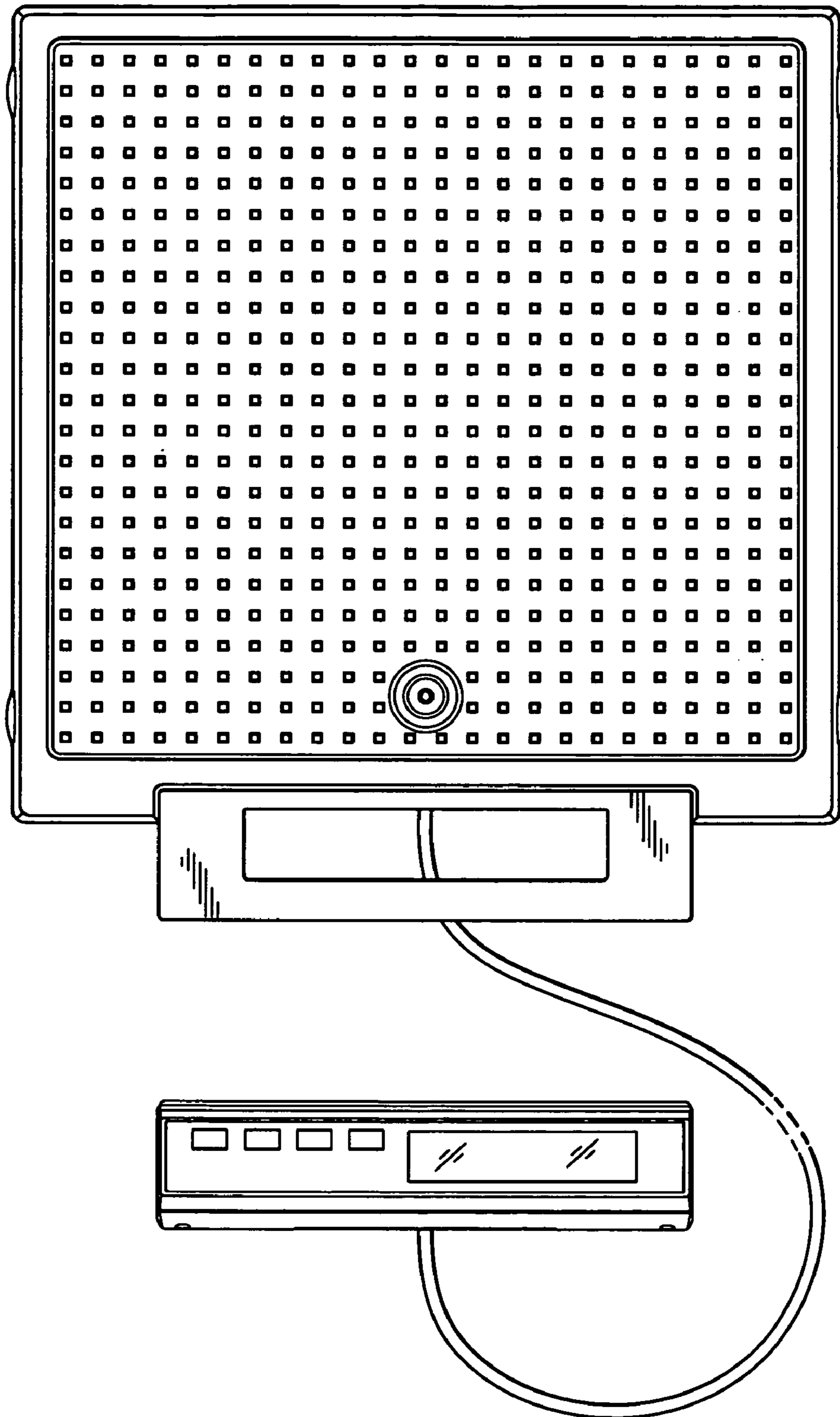
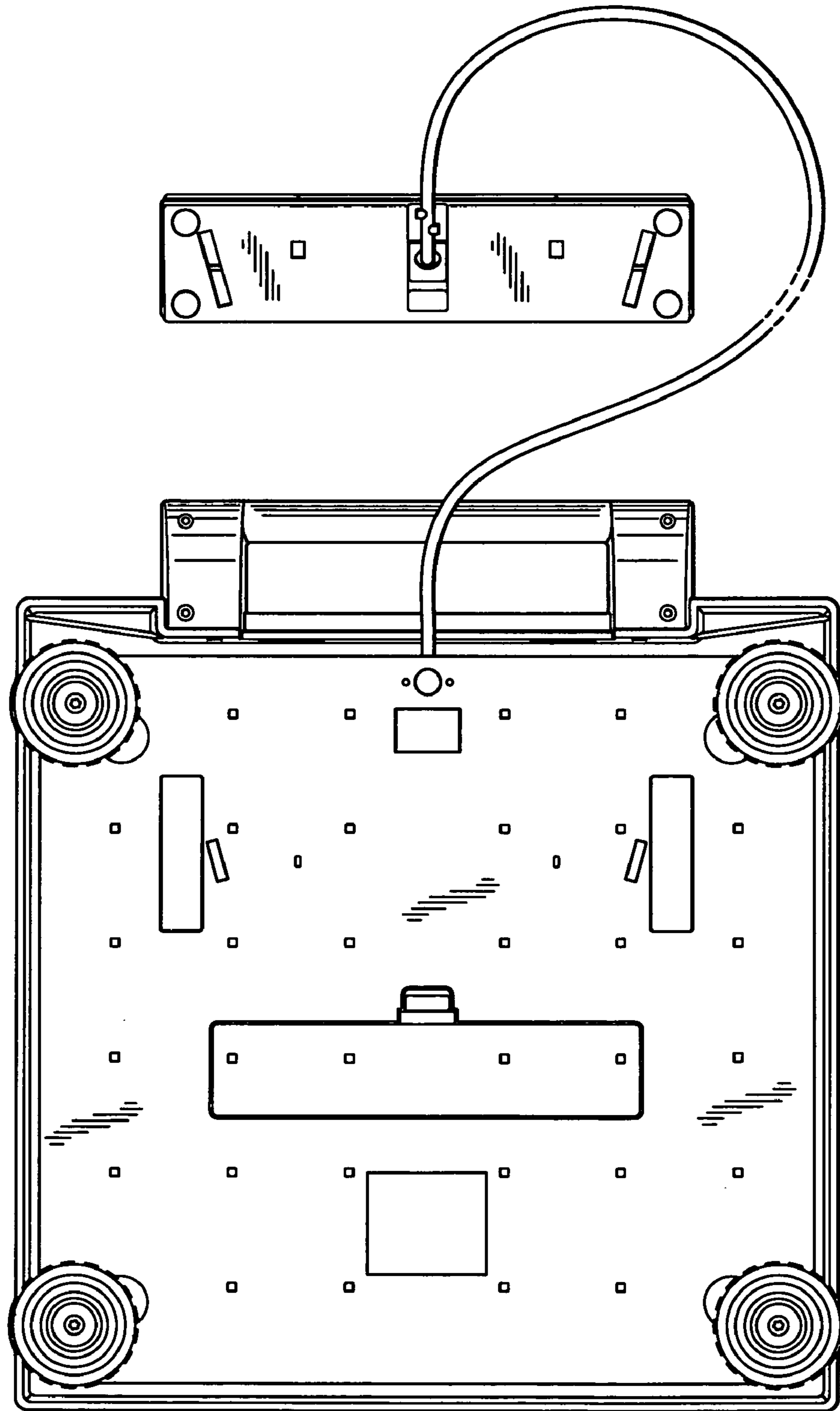

Fig. 4



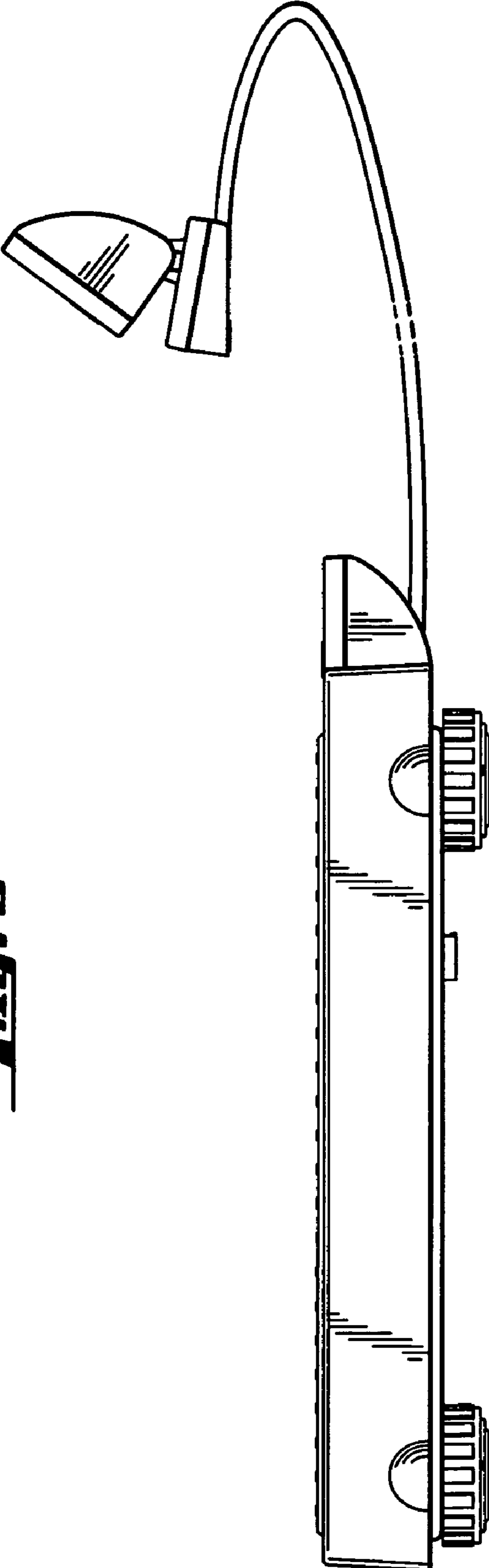

Fig. 5

Fig. 6

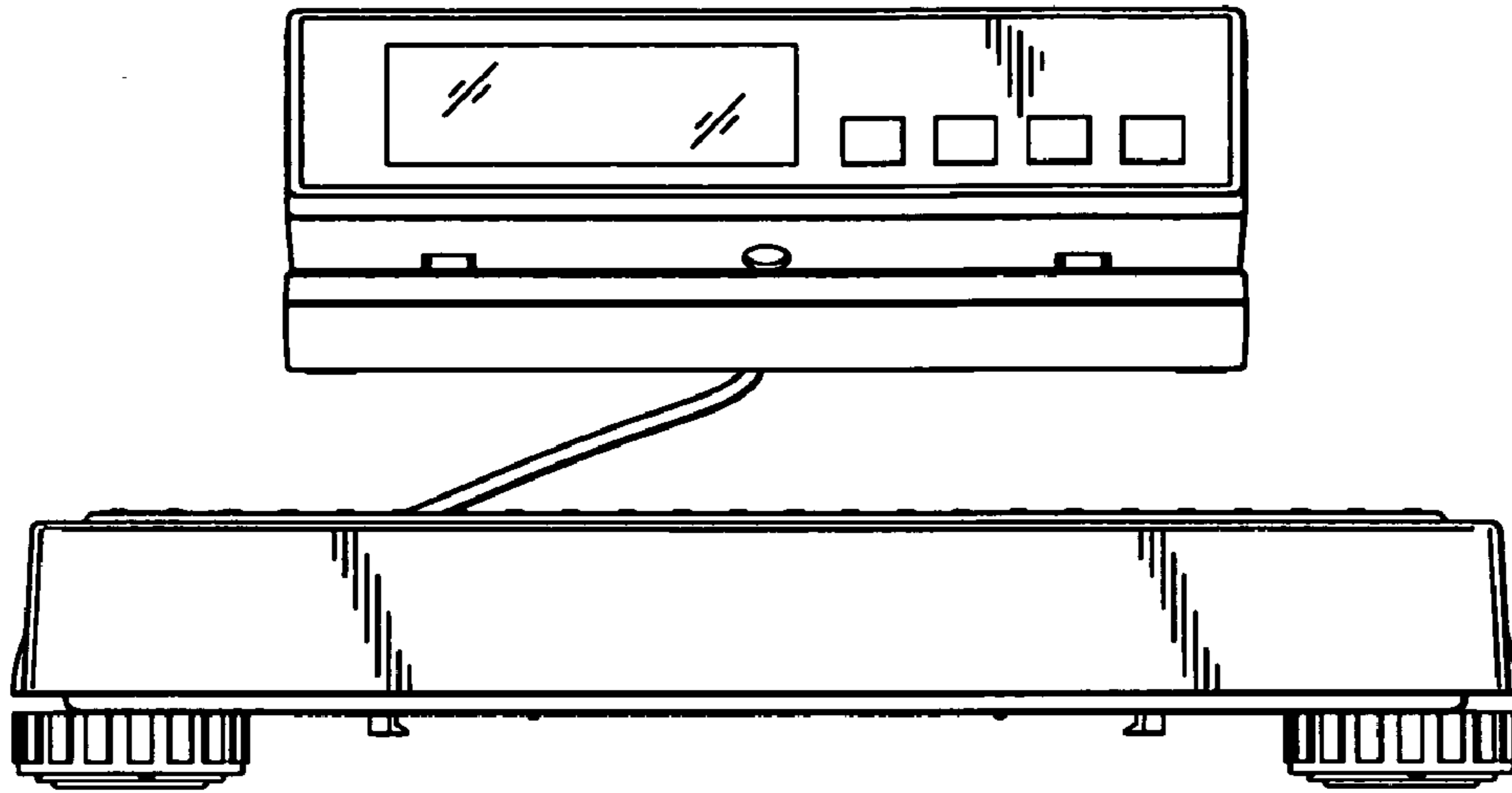

Fig. 7

