



US00D587141S

(12) **United States Design Patent**
King et al.

(10) **Patent No.:** **US D587,141 S**

(45) **Date of Patent:** **** Feb. 24, 2009**

(54) **PARKING METER**

(75) Inventors: **David William King**, Rancho Santa Fe, CA (US); **Alexander Schwarz**, San Diego, CA (US)

(73) Assignee: **IPS Group, Inc.**, San Diego, CA (US)

(**) Term: **14 Years**

(21) Appl. No.: **29/320,129**

(22) Filed: **Jun. 20, 2008**

Related U.S. Application Data

(62) Division of application No. 29/279,021, filed on Apr. 17, 2007, now Pat. No. Des. 575,168.

(51) **LOC (9) Cl.** **10-03**

(52) **U.S. Cl.** **D10/42**

(58) **Field of Classification Search** D10/40-45;
194/217, 350; 340/932.2; 705/13
See application file for complete search history.

(56) **References Cited**

U.S. PATENT DOCUMENTS

D98,810 S *	3/1936	Magee	D10/42
D116,805 S	9/1939	Reznek		
D162,698 S *	3/1951	Teague	D10/42
D166,059 S	2/1952	Yoss		
D189,106 S *	10/1960	Leiderman	D10/42
D199,270 S *	9/1964	Michales	D10/42
D200,216 S *	2/1965	Broussard	D10/42
5,617,942 A	4/1997	Ward, II et al.		
5,732,812 A	3/1998	Grainger et al.		
D393,212 S *	4/1998	Lucas	D10/42

5,805,083 A	9/1998	Sutton et al.		
5,841,369 A	11/1998	Sutton et al.		
D412,289 S	7/1999	Winwood		
5,966,345 A	10/1999	Dee et al.		
6,109,418 A	8/2000	Yost		
6,243,028 B1	6/2001	Krygler et al.		
D461,728 S	8/2002	Tuxen et al.		
6,747,575 B2 *	6/2004	Chauvin et al.	340/932.2
D575,168 S	8/2008	King et al.		

* cited by examiner

Primary Examiner—Robert M Spear

Assistant Examiner—George D Kirschbaum

(74) *Attorney, Agent, or Firm*—Townsend and Townsend and Crew LLP

(57) **CLAIM**

We claim the ornamental design for a parking meter, as shown and described.

DESCRIPTION

FIG. 1 is a front left perspective view of a parking meter showing our new design;

FIG. 2 is a front elevation view thereof;

FIG. 3 is a left side elevation view thereof;

FIG. 4 is a right side elevation view thereof;

FIG. 5 is a plan view (from above) thereof; and,

FIG. 6 is a rear perspective view thereof.

In the drawings, the broken line showing of a base portion, surface labeling on the front display window, and status indicator depict environmental subject matter and forms no part of the claim.

1 Claim, 6 Drawing Sheets

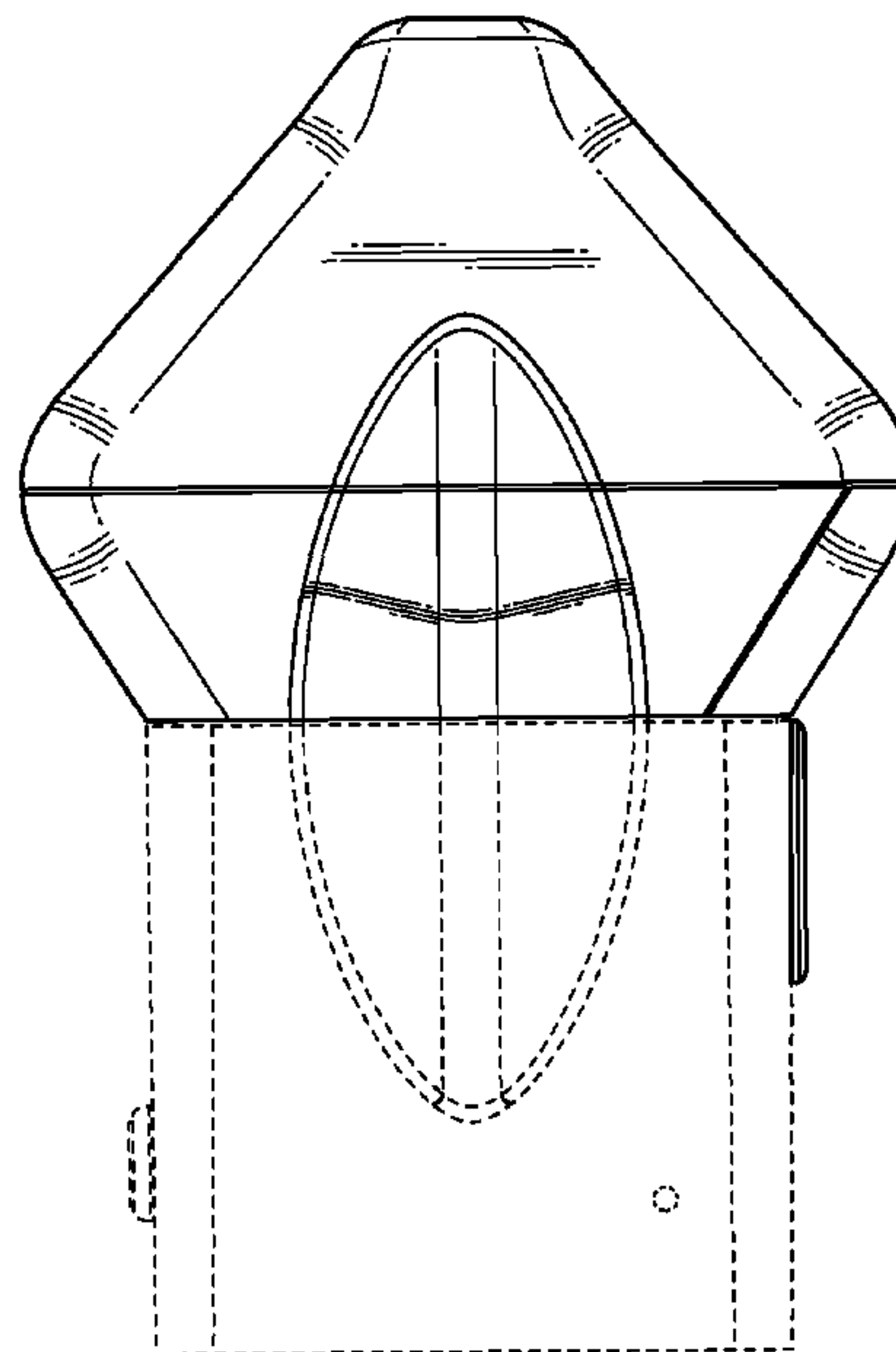
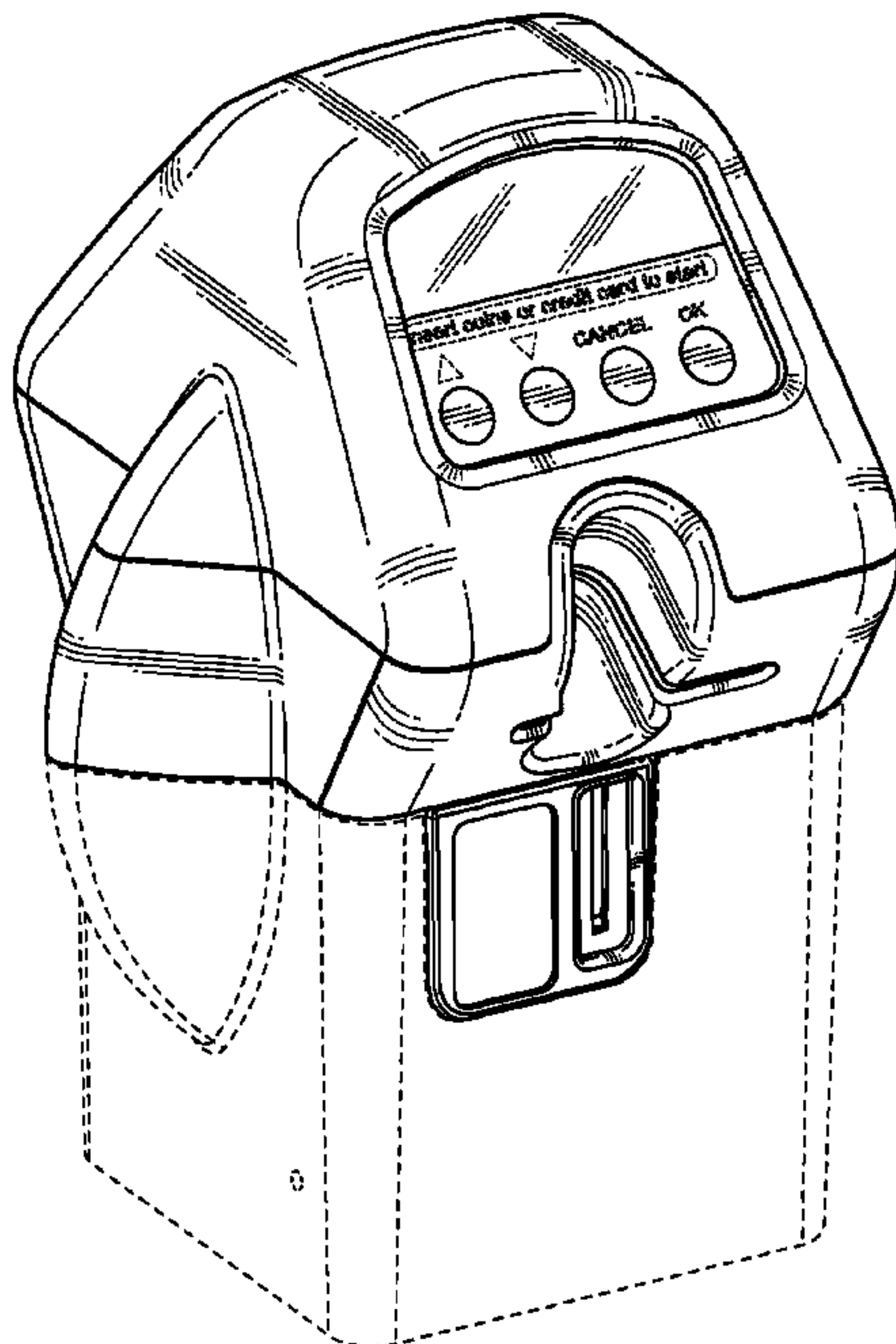

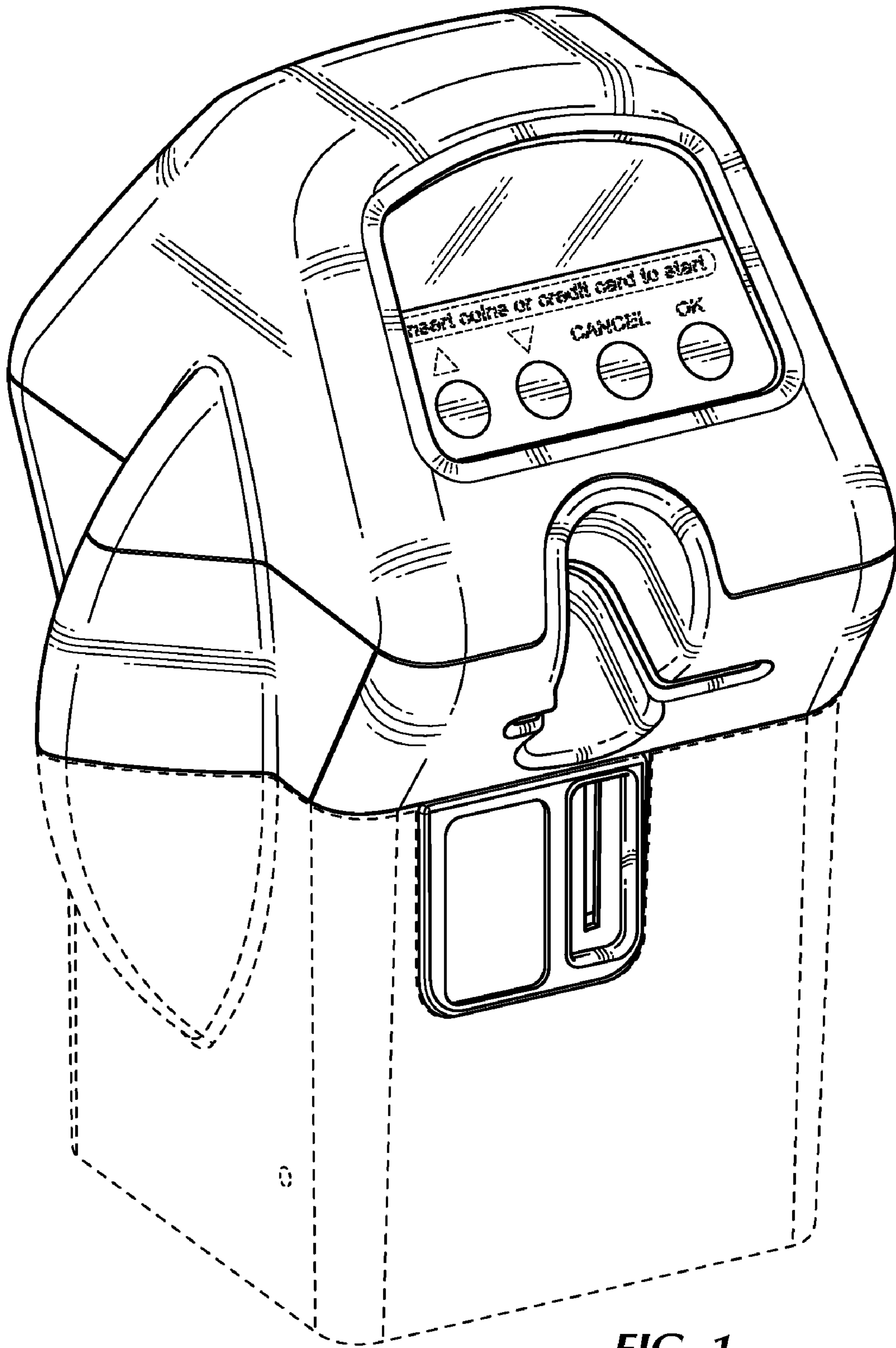

FIG. 1

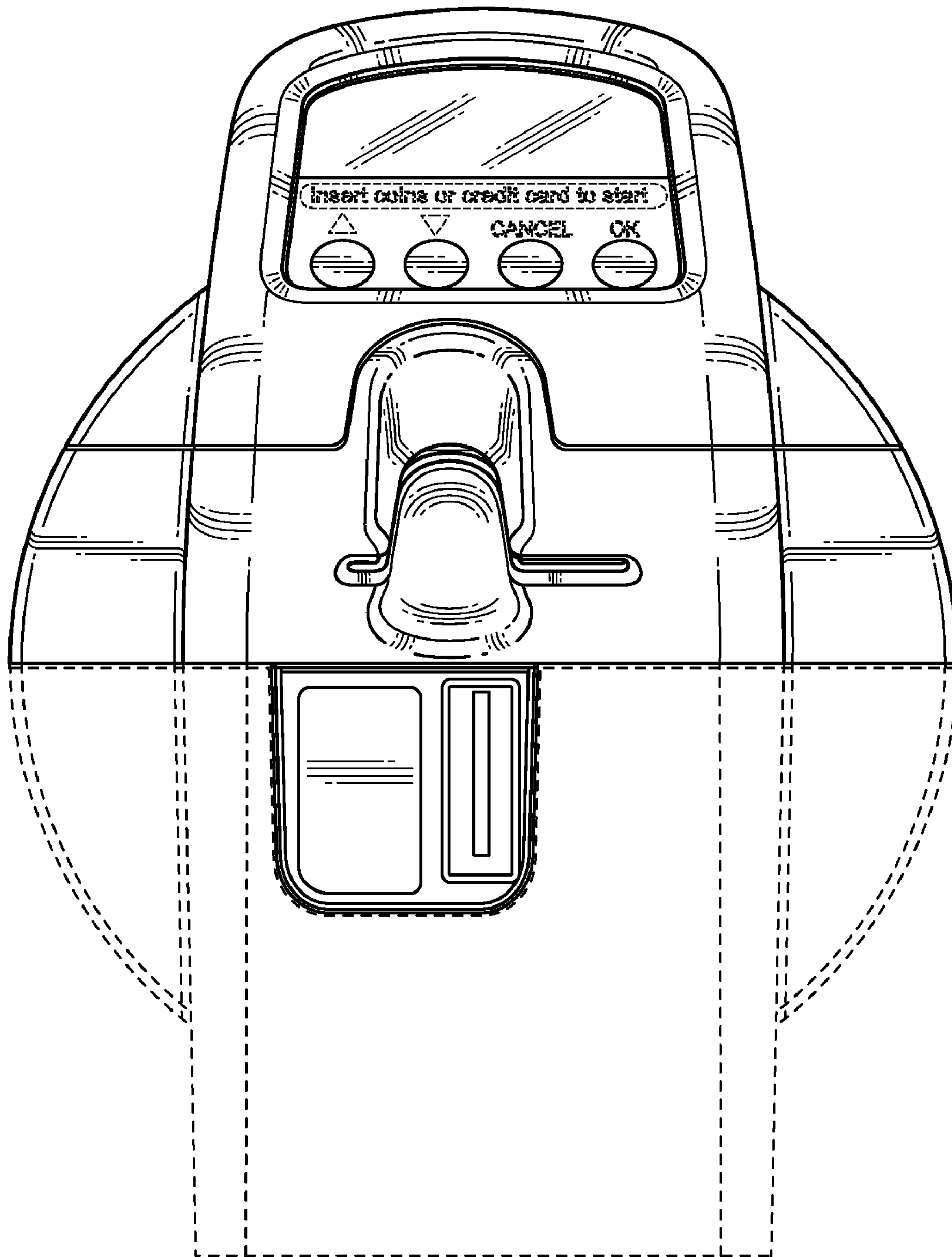

FIG. 2

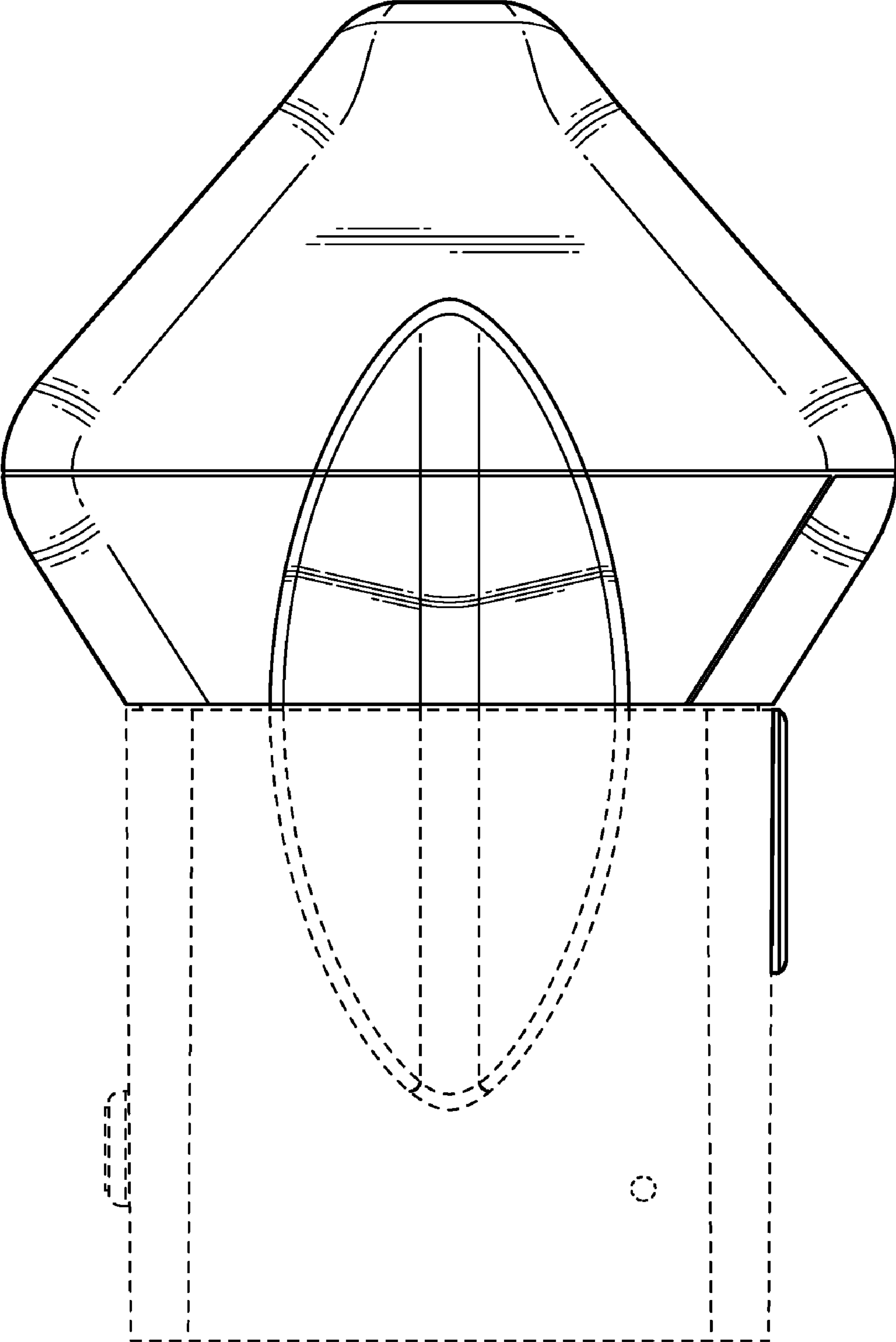

FIG. 3

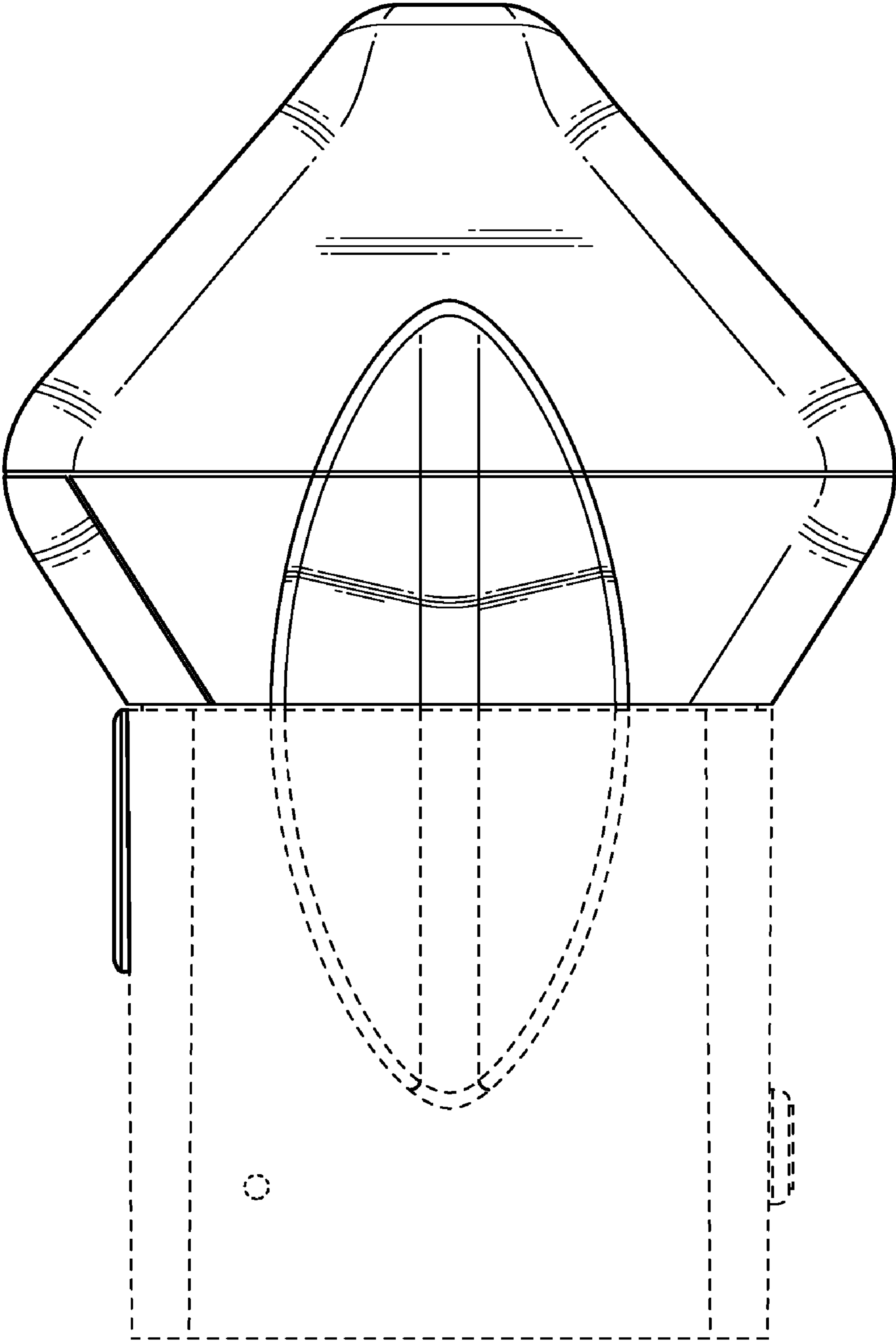

FIG. 4

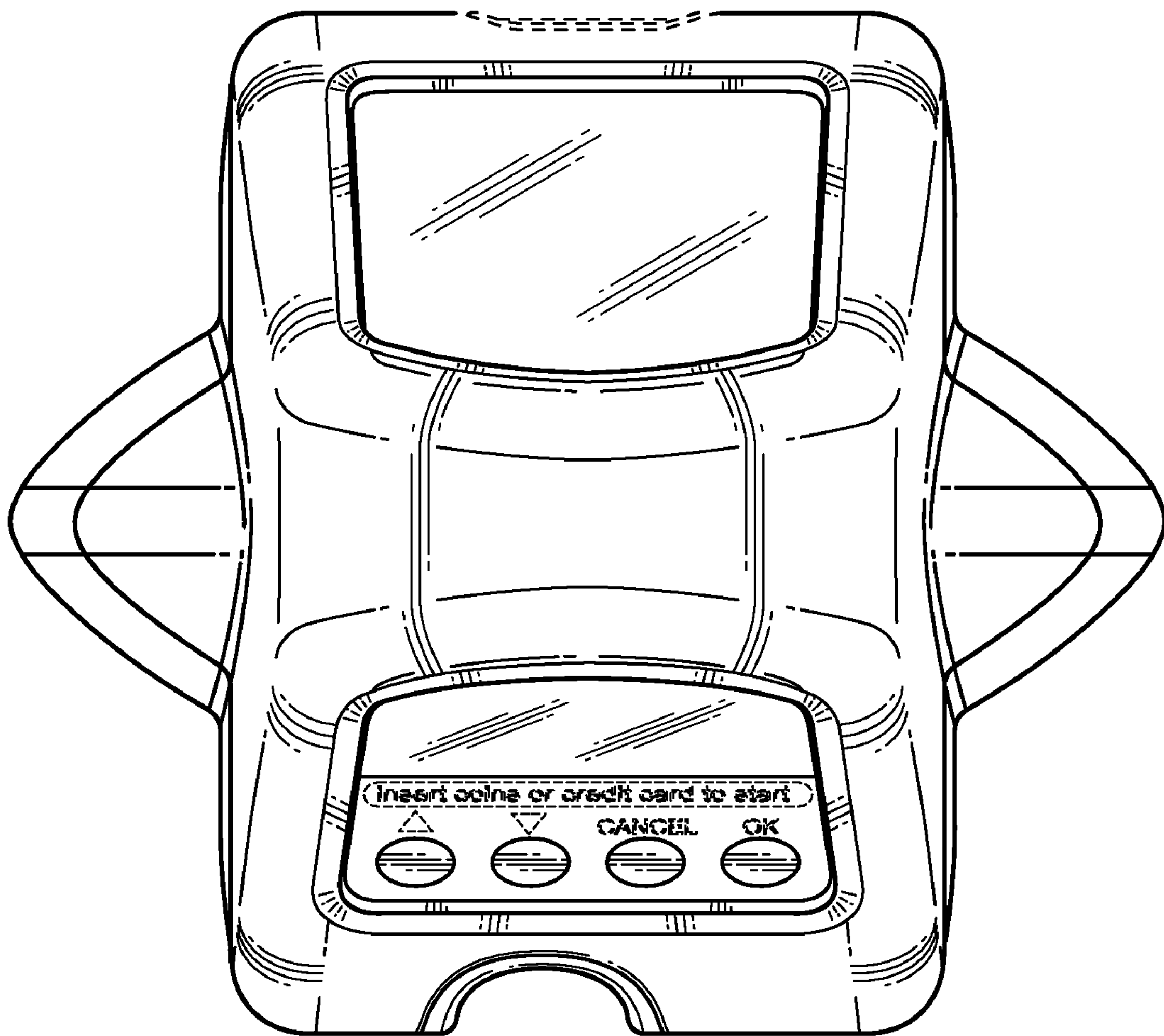

FIG. 5

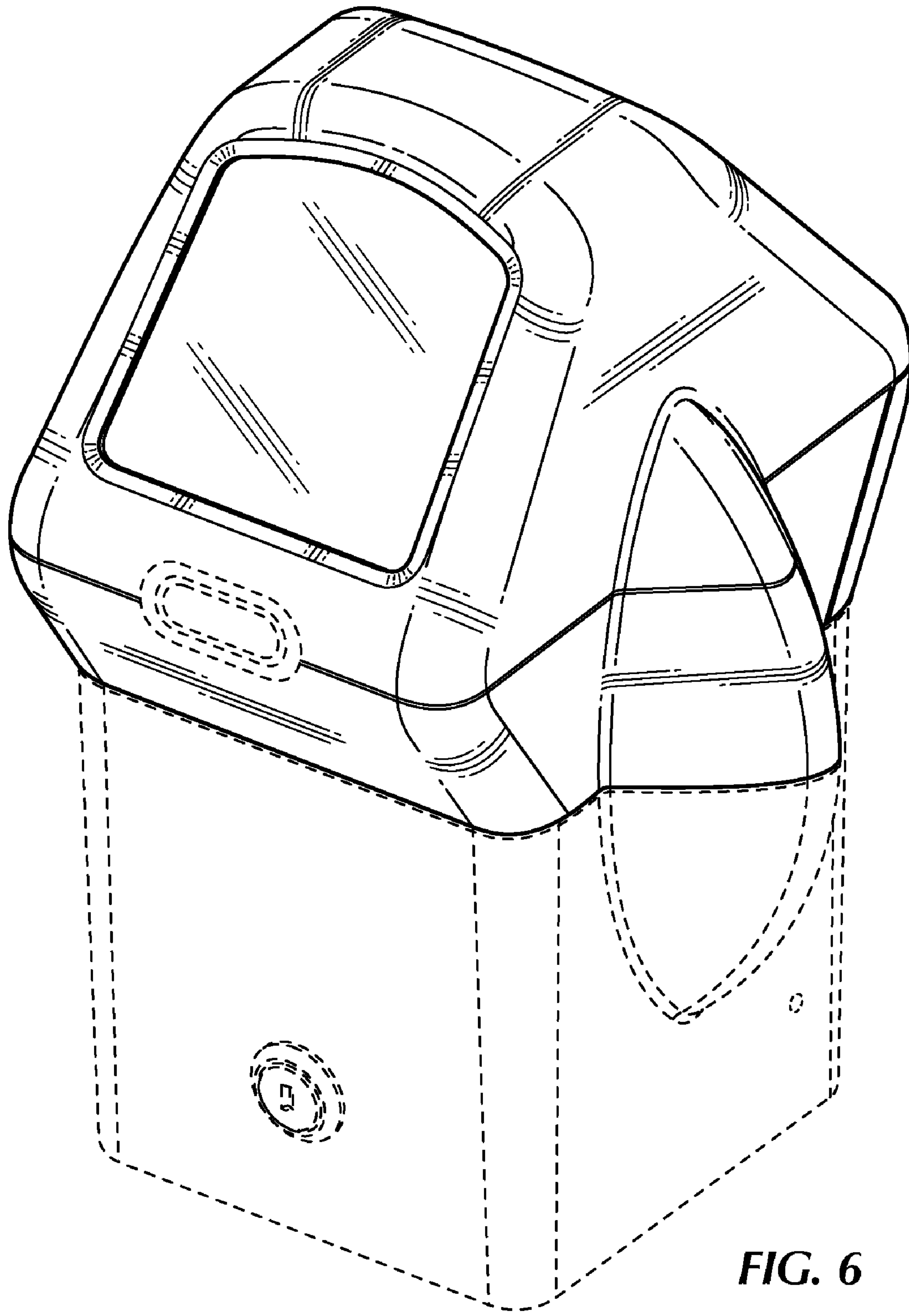

FIG. 6