



US00D587030S

(12) **United States Design Patent**
Scoley et al.

(10) **Patent No.:** **US D587,030 S**

(45) **Date of Patent:** **** Feb. 24, 2009**

(54) **BEVERAGE BAR FOR AN AIRCRAFT**

(57) **CLAIM**

(75) Inventors: **Ian Scoley**, Hamburg (DE); **Paul Priestman**, London (GB)

The ornamental design for beverage bar for an aircraft, as shown and described.

(73) Assignee: **Airbus Deutschland GmbH** (DE)

DESCRIPTION

(**) Term: **14 Years**

FIG. 1 is a perspective view of a beverage bar for an aircraft showing my new design;

(21) Appl. No.: **29/286,690**

FIG. 2 is a front plan view;

(22) Filed: **May 16, 2007**

FIG. 3 is a back plan view;

(30) **Foreign Application Priority Data**

Nov. 16, 2006	(EM)	000622170-0002
Nov. 16, 2006	(EM)	000622170-0003
Nov. 16, 2006	(EM)	000622170-0004
Nov. 16, 2006	(EM)	000622170-0005
Nov. 16, 2008	(EM)	000622170-0001

FIG. 4 is a left side view;

FIG. 5 is a right side view;

FIG. 6 is a top plan view;

FIG. 7 is a bottom plan view;

(51) **LOC (9) Cl.** **06-04**

(52) **U.S. Cl.** **D6/397**

(58) **Field of Classification Search** D6/396,
D6/397, 449, 467, 486, 480, 495; D25/23,
D25/1, 16, 32; 108/150, 161, 155-157, 25,
108/23, 33

FIG. 8 is a front perspective view of a beverage bar for an aircraft in FIG. 1 in an open position;

FIG. 9 is a front plan view;

FIG. 10 is a back plan view;

FIG. 11 is a left side view;

FIG. 12 is a right side view;

FIG. 13 is a top plan view;

FIG. 14 is a bottom plan view;

See application file for complete search history.

FIG. 15 is a front perspective view of a beverage bar for an aircraft in FIG. 1 in an extended state;

FIG. 16 is a front plan view;

FIG. 17 is a back view;

FIG. 18 is a left view;

FIG. 19 is a right view;

FIG. 20 is a top plan view; and,

FIG. 21 a bottom plan view.

(56) **References Cited**

U.S. PATENT DOCUMENTS

D240,778 S *	8/1976	Mason	D6/467
D262,912 S *	2/1982	Therien et al.	D25/23
D489,549 S *	5/2004	D'Oria et al.	D6/480

The broken lines shown in the drawings are for illustrative purposes only and form no part of the claim design of the embodiments in which they appear.

* cited by examiner

Primary Examiner—Janice E Seeger

Assistant Examiner—Sydney R Buffalow

(74) *Attorney, Agent, or Firm*—Lerner, David, Littenberg, Krumholz & Mentlik, LLP

1 Claim, 21 Drawing Sheets

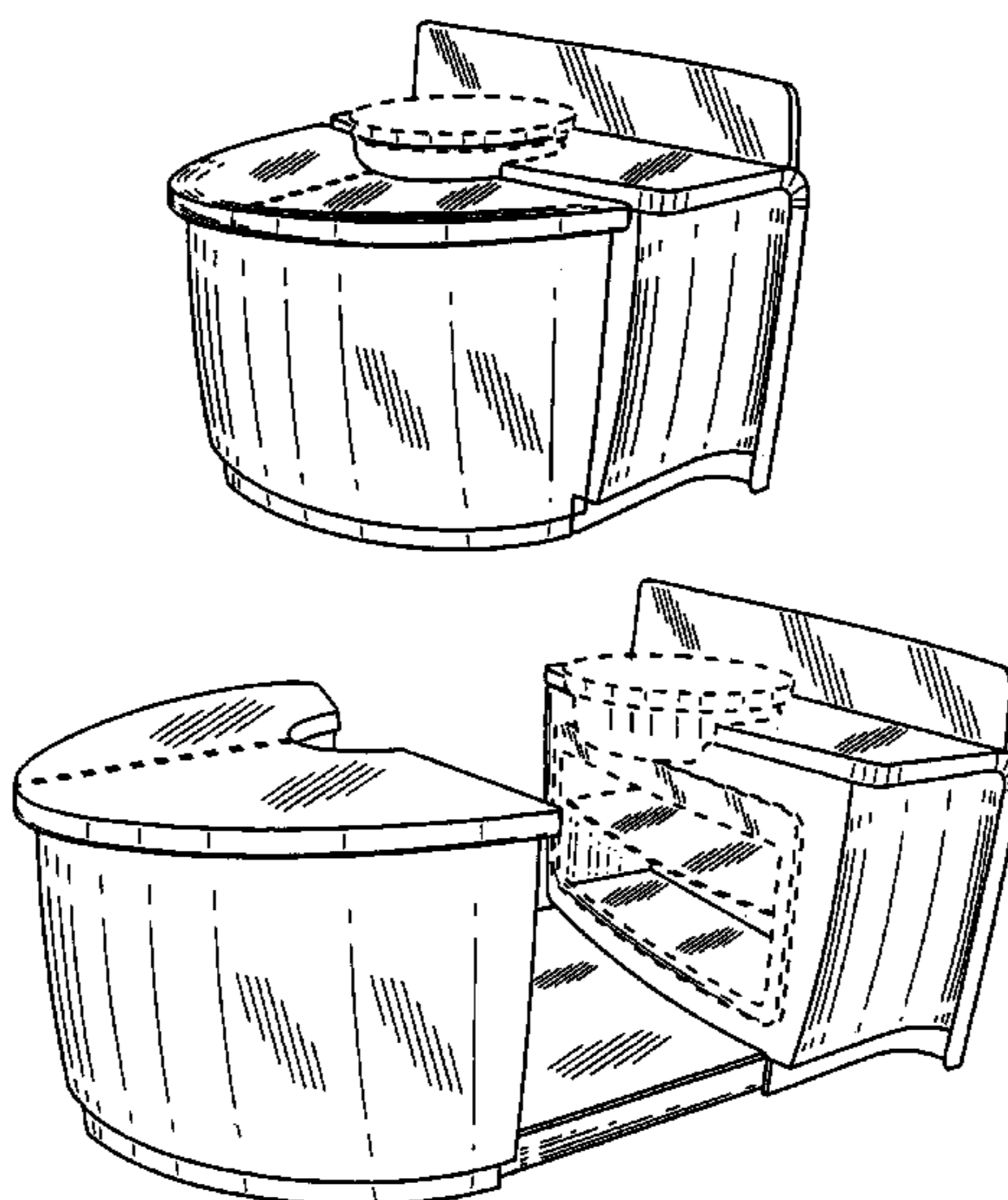

FIG. 1

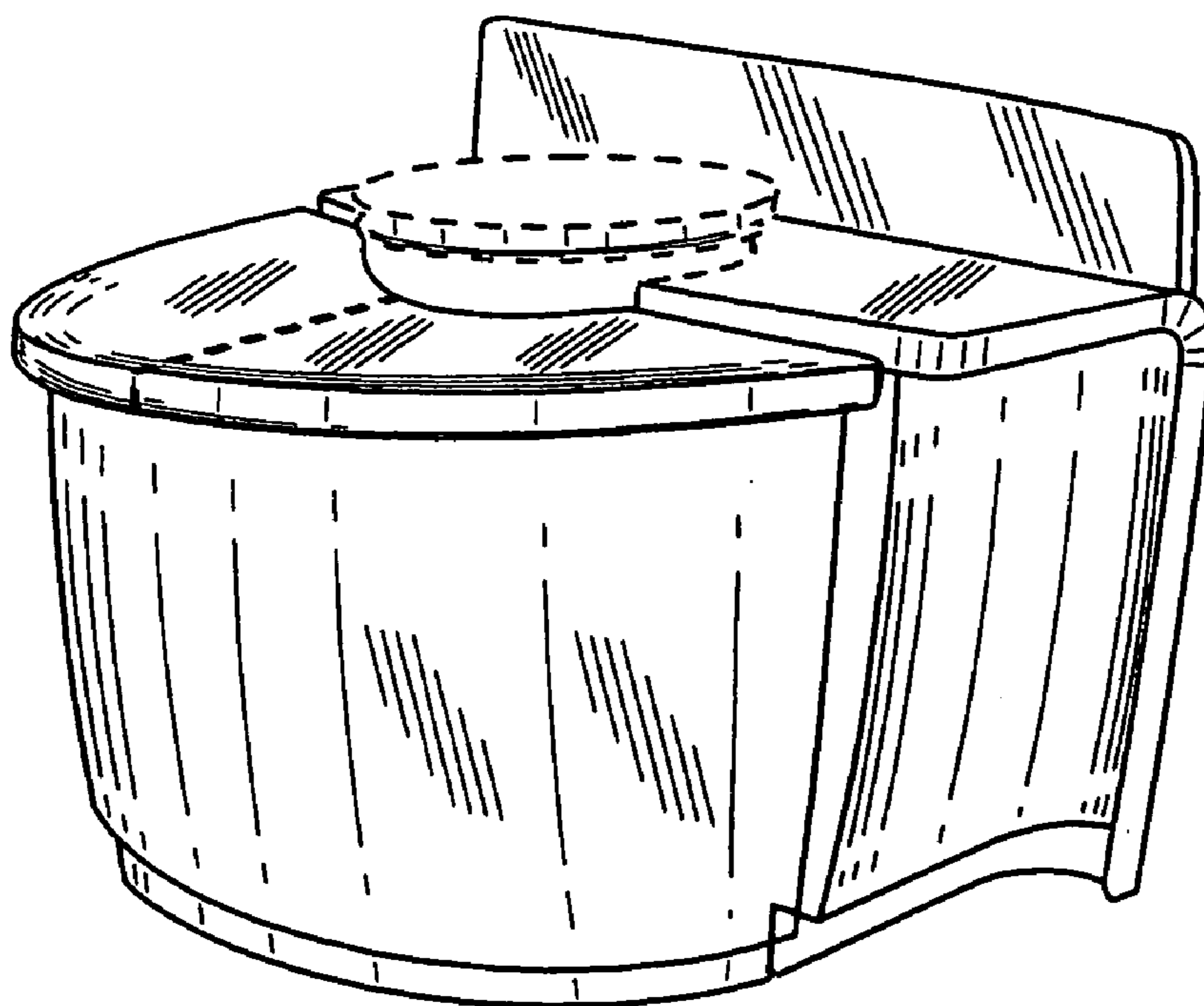

FIG. 2

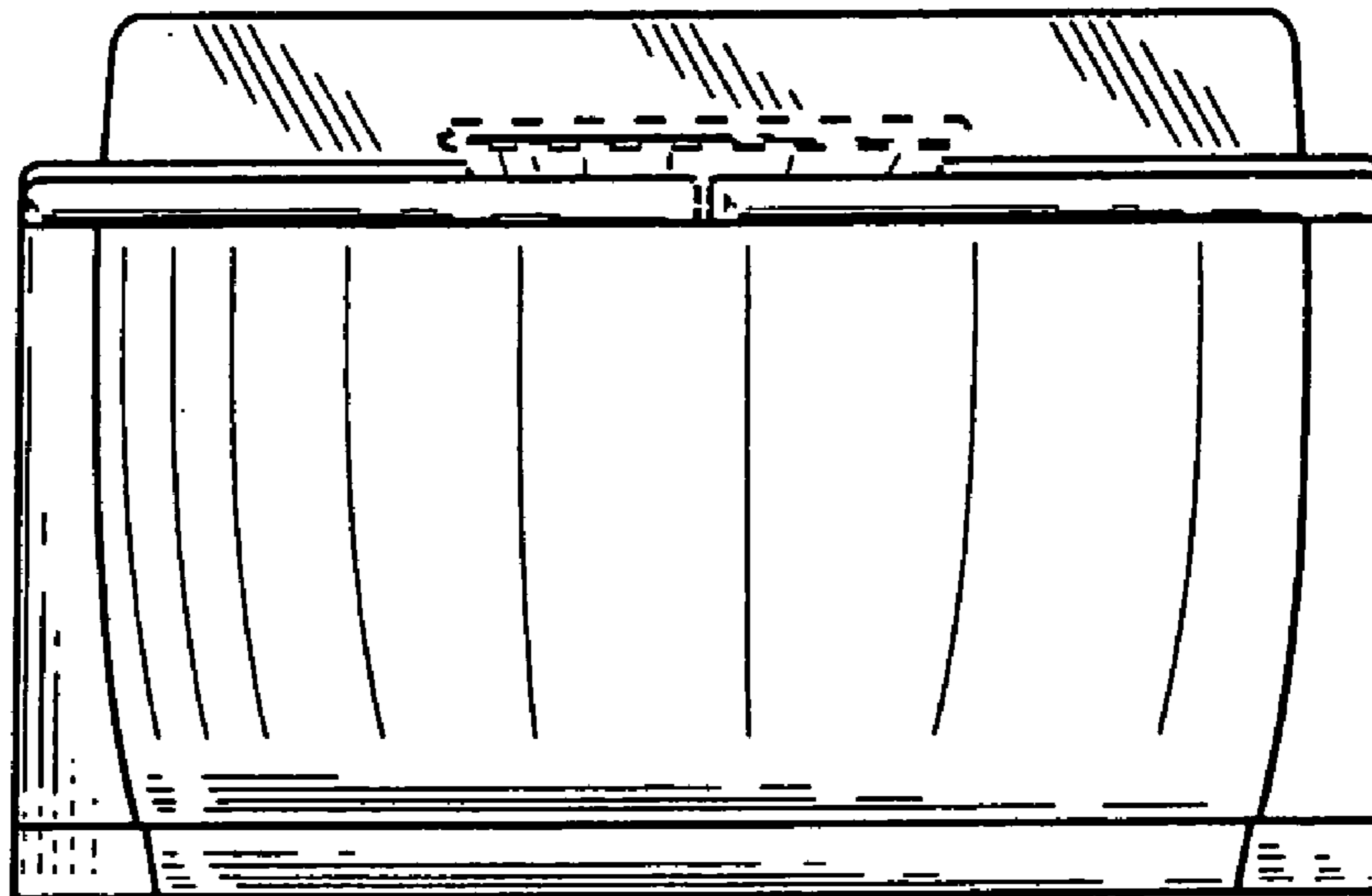

FIG. 3

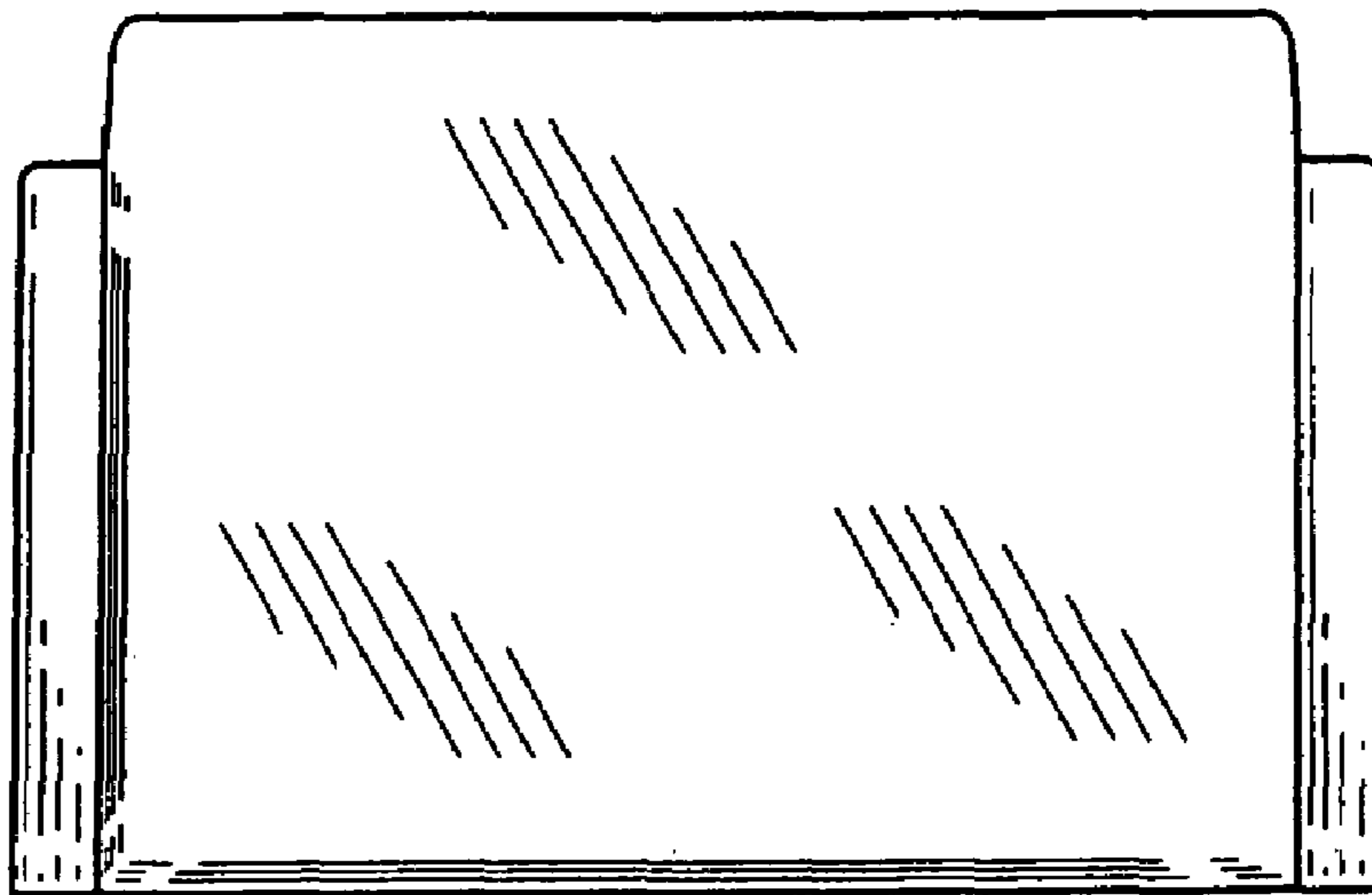

FIG. 4

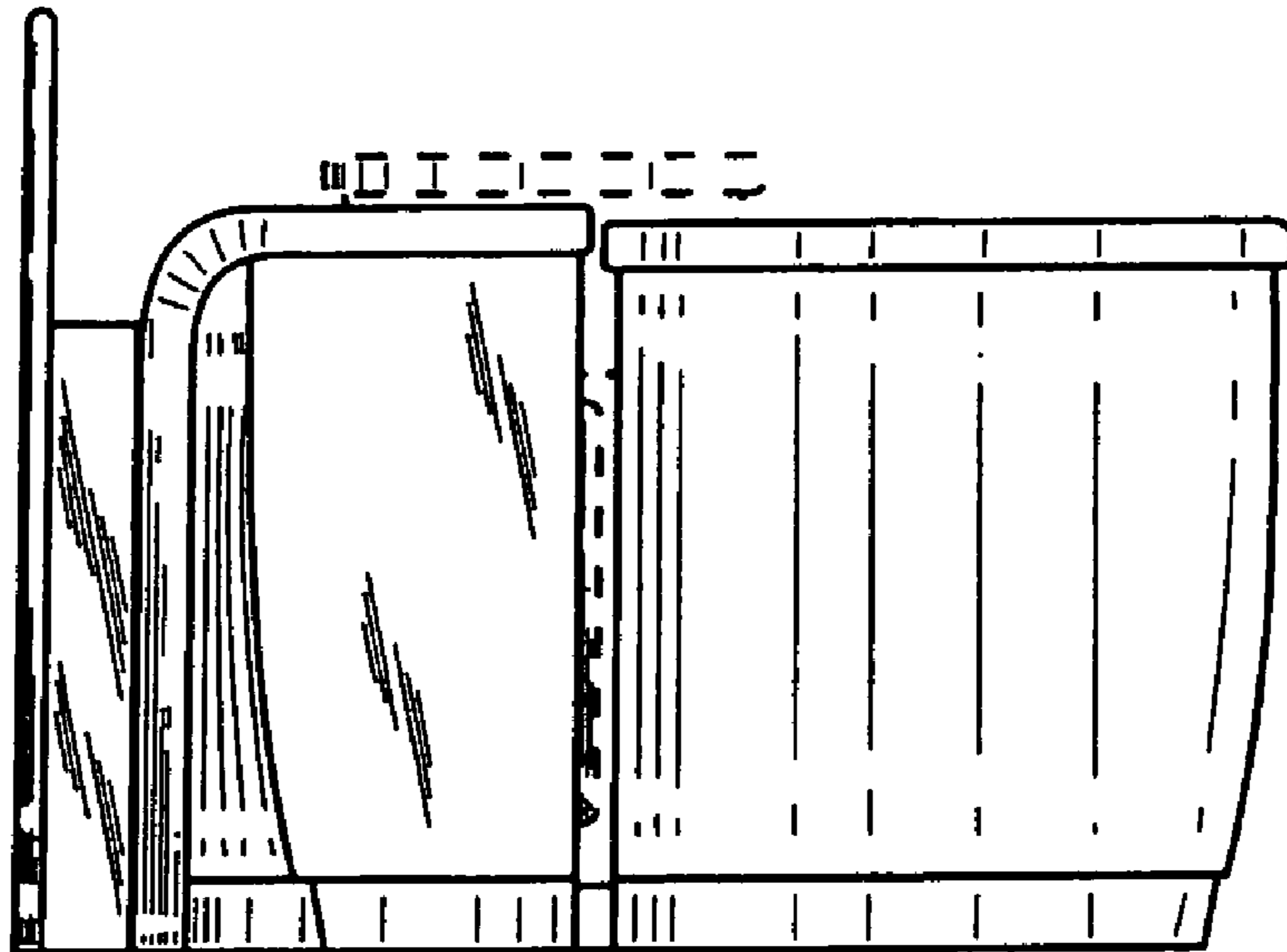

FIG. 5

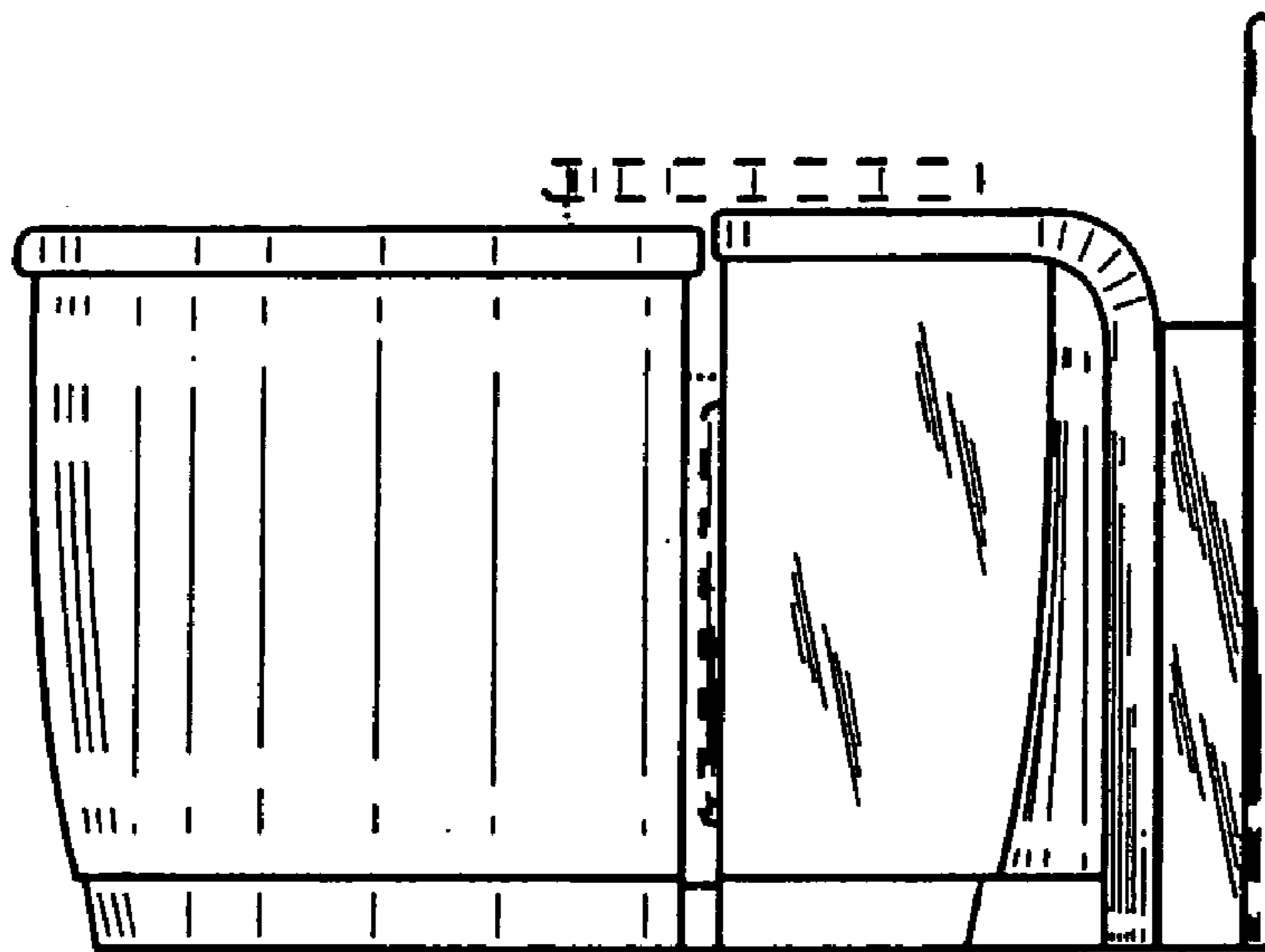

FIG. 6

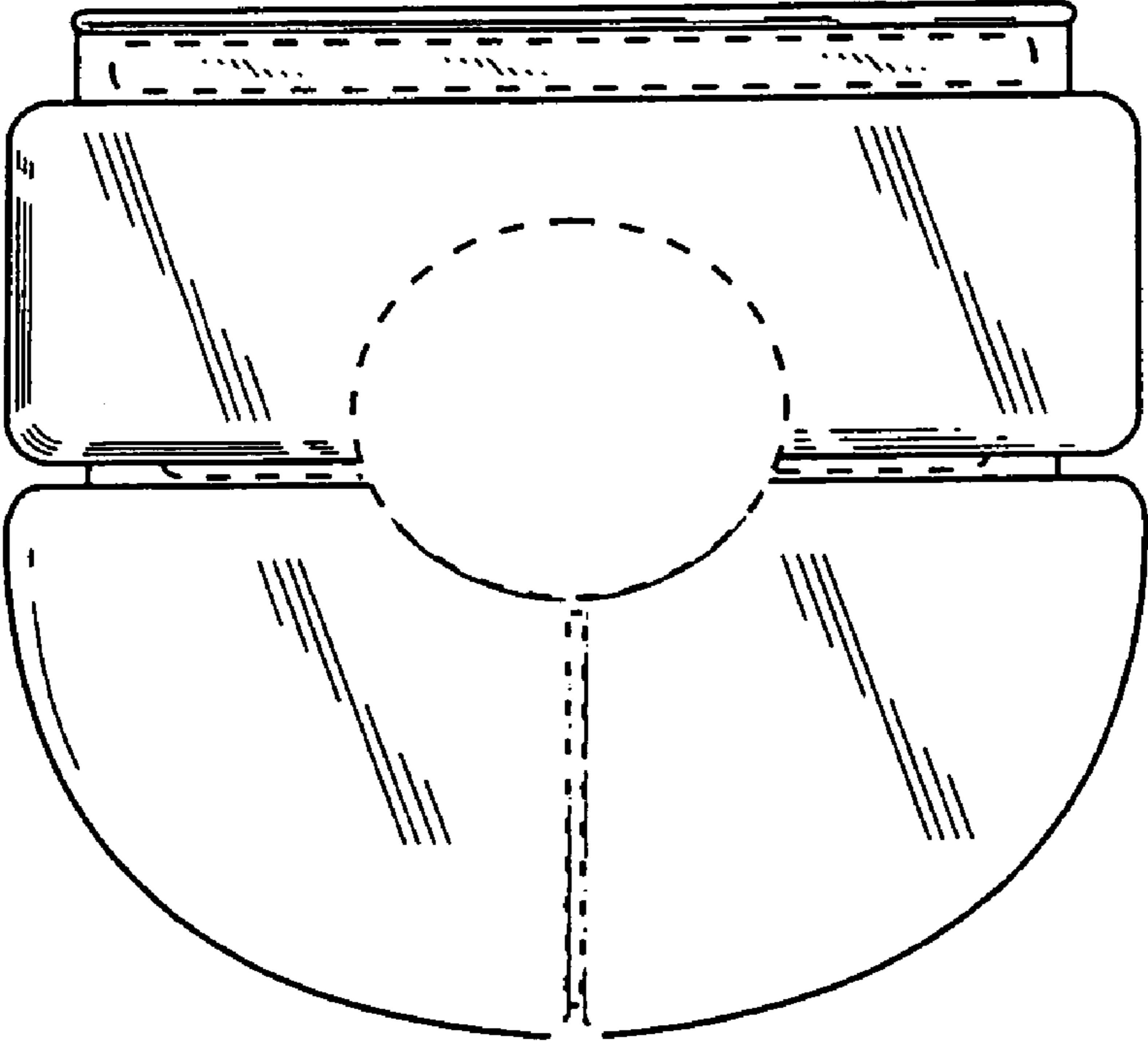

FIG. 7

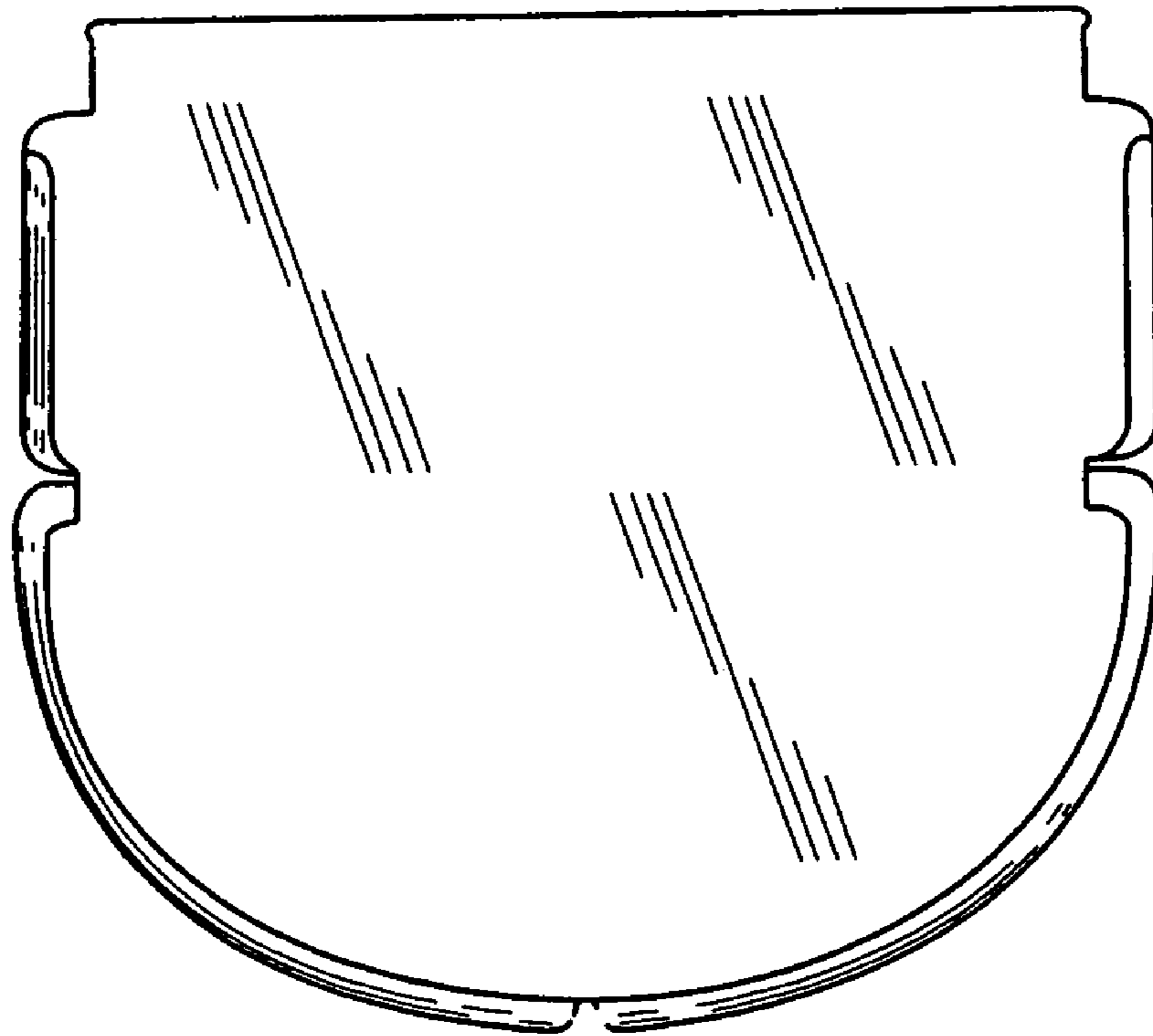

FIG. 8

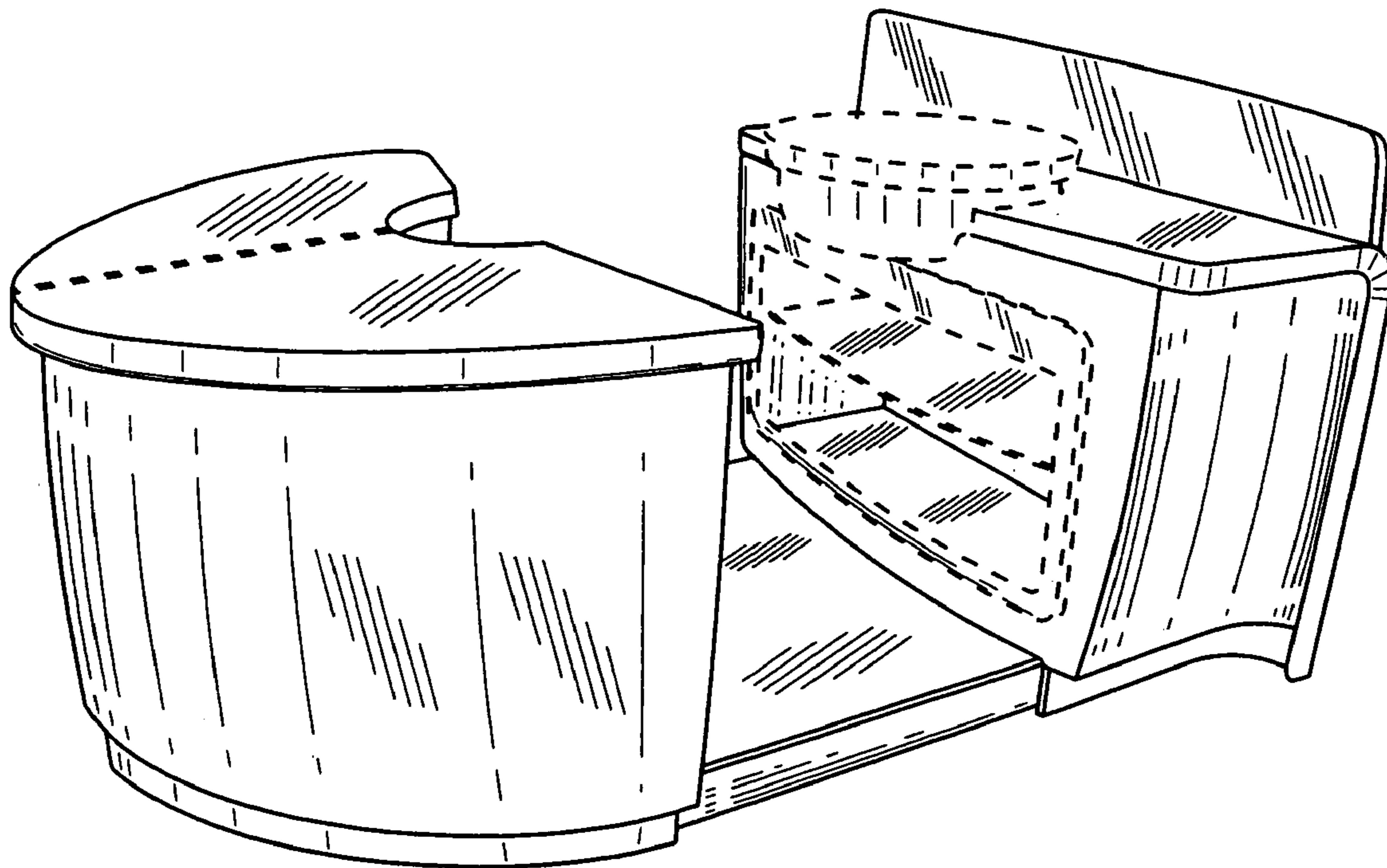

FIG. 9

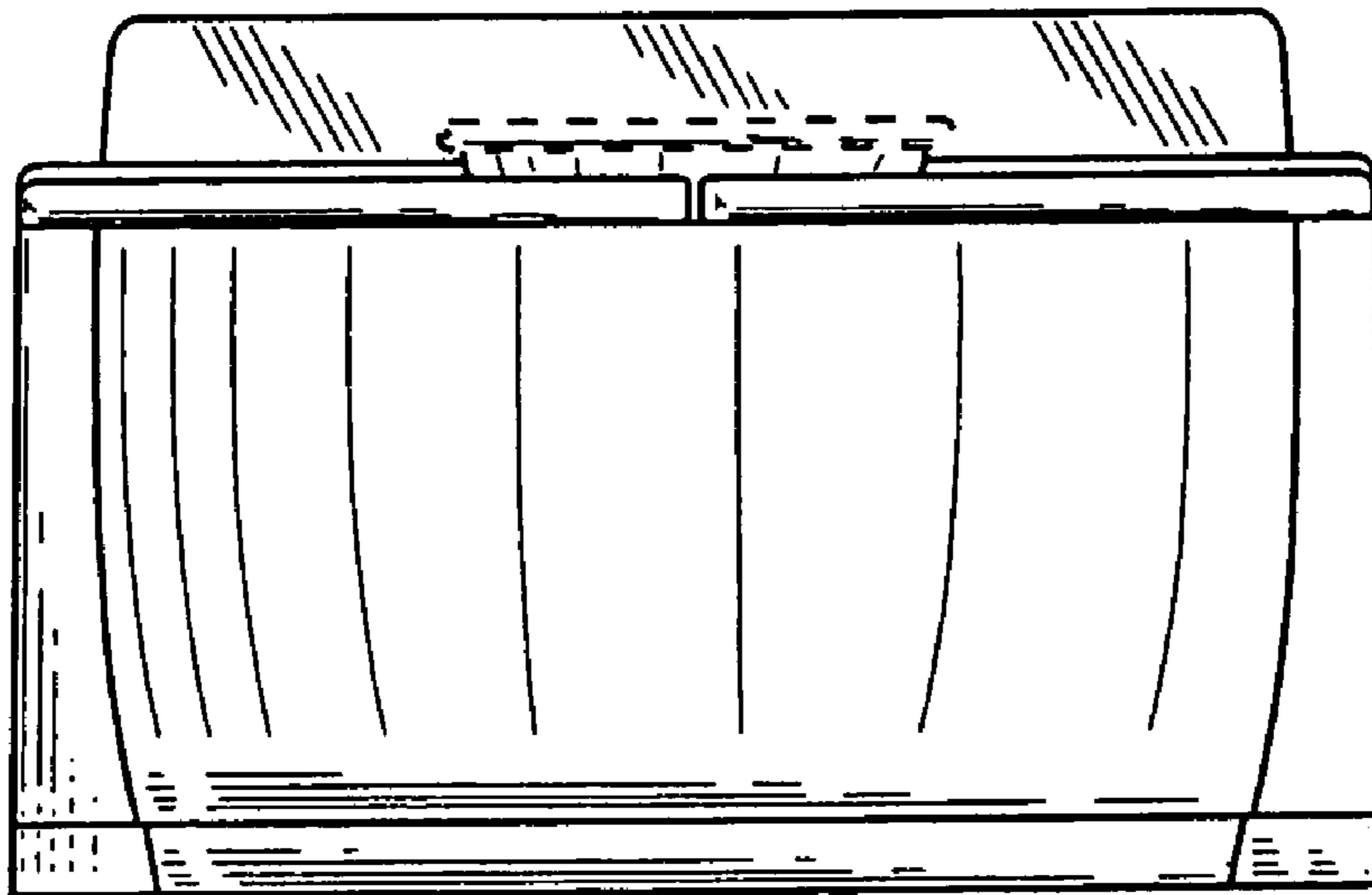

FIG. 10

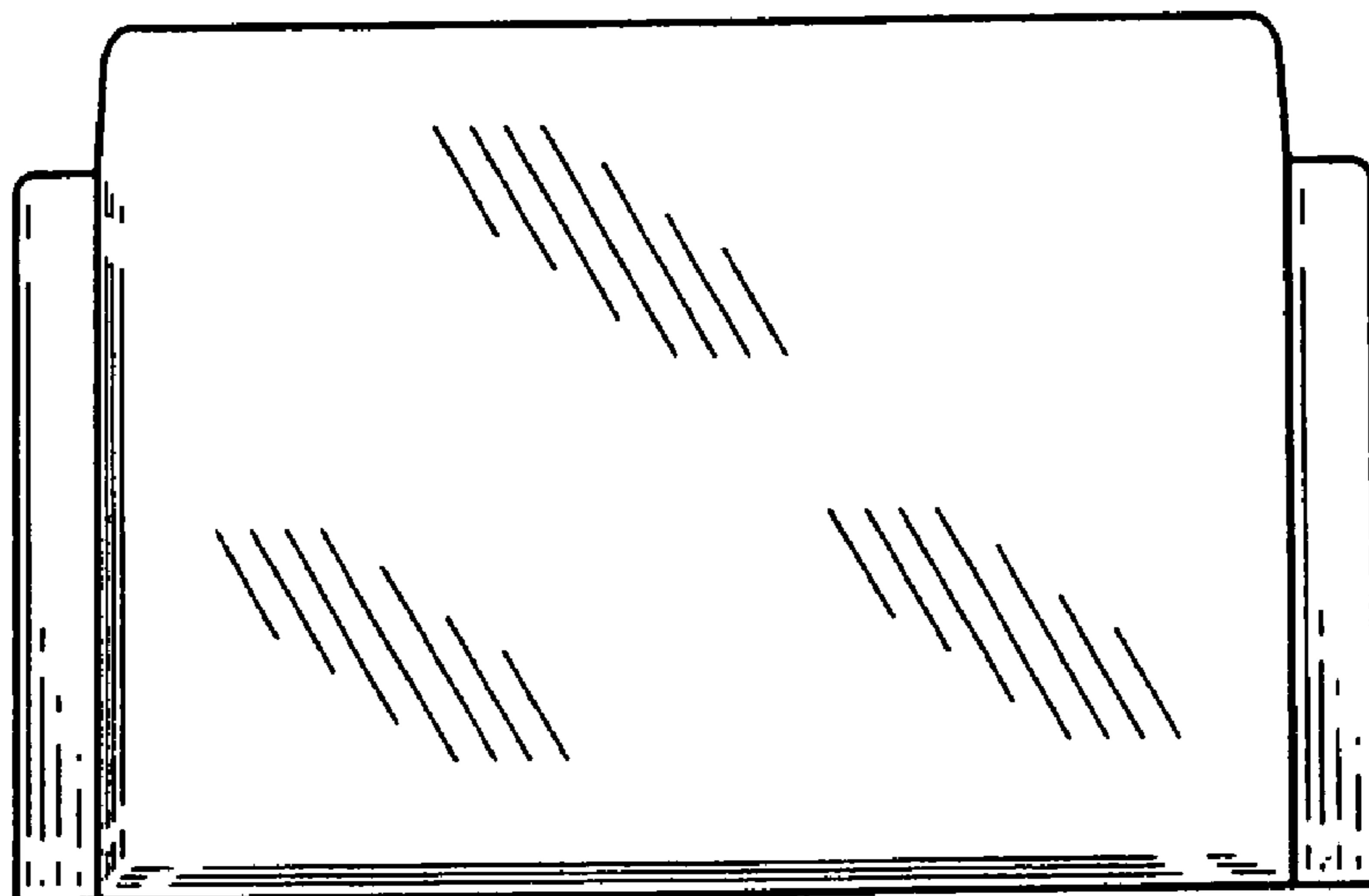

FIG. 11

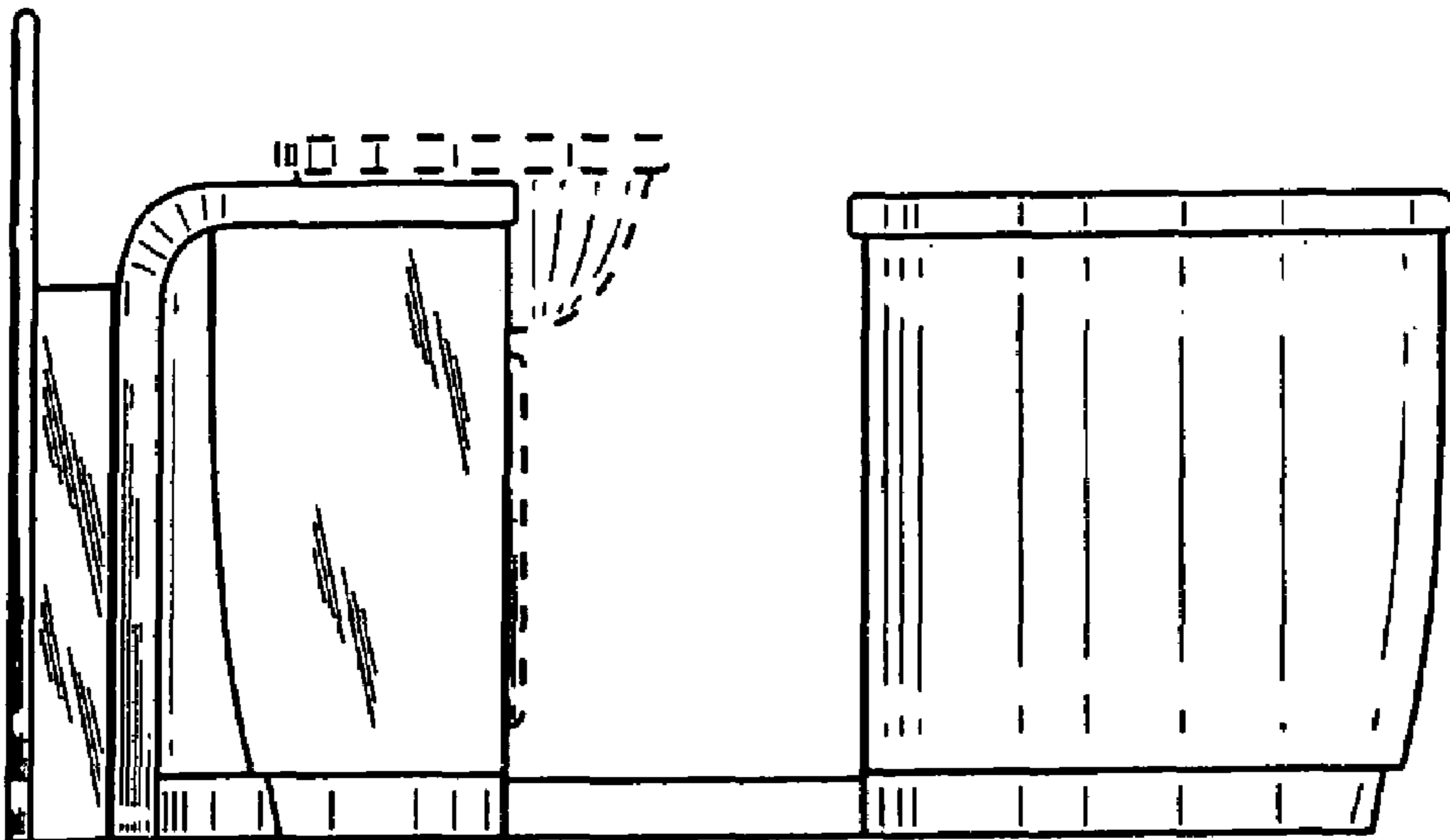

FIG. 12

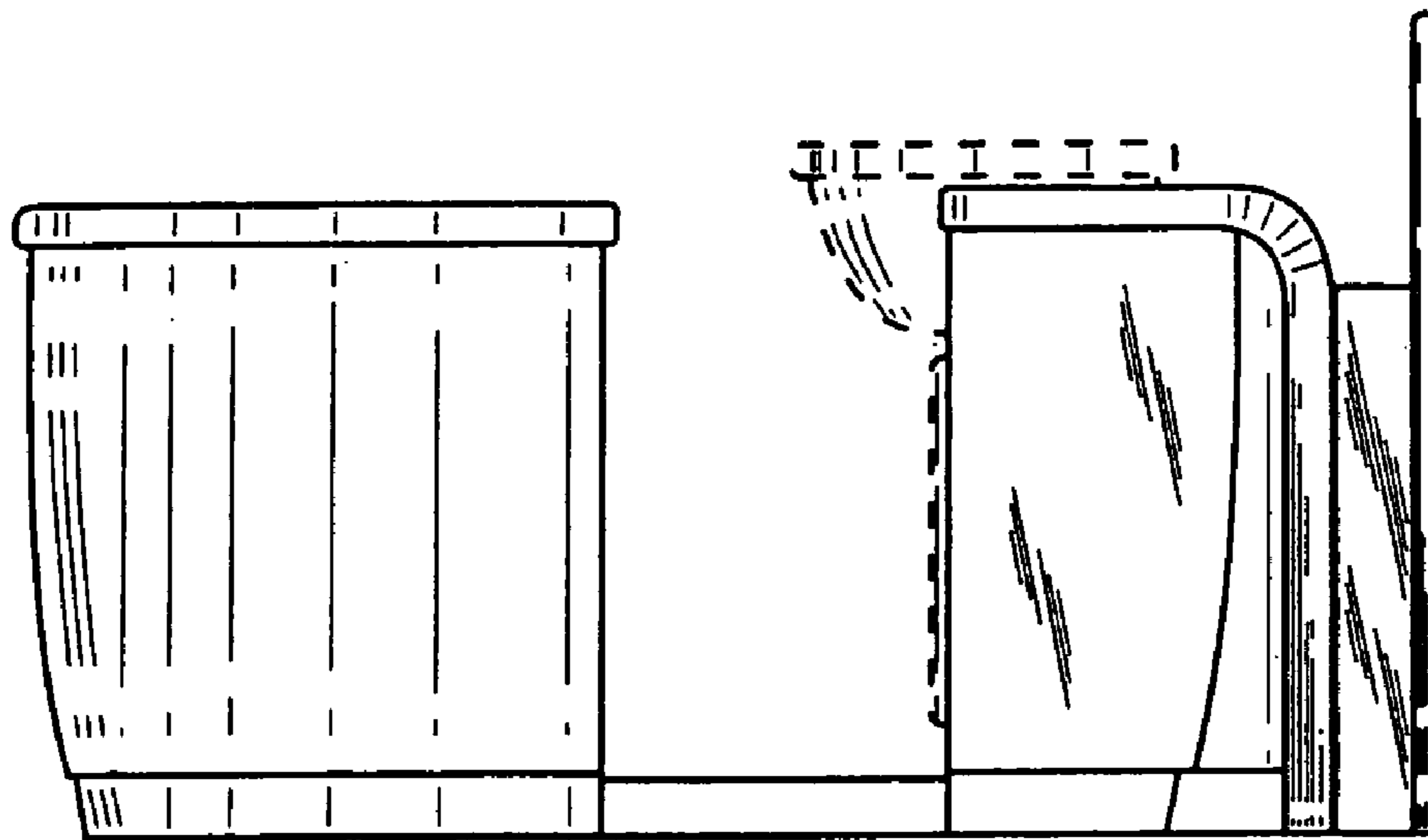

FIG. 13

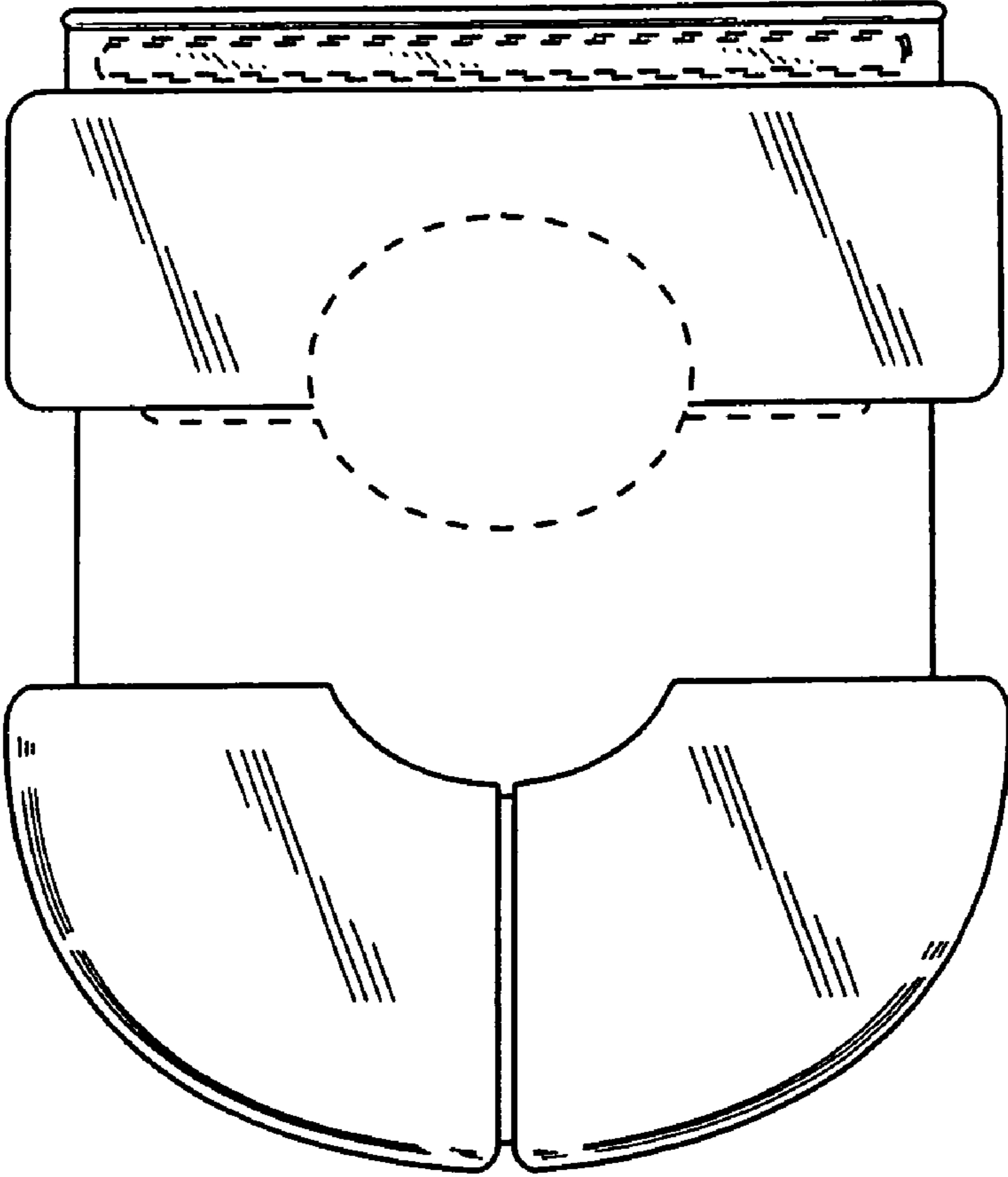

FIG. 14

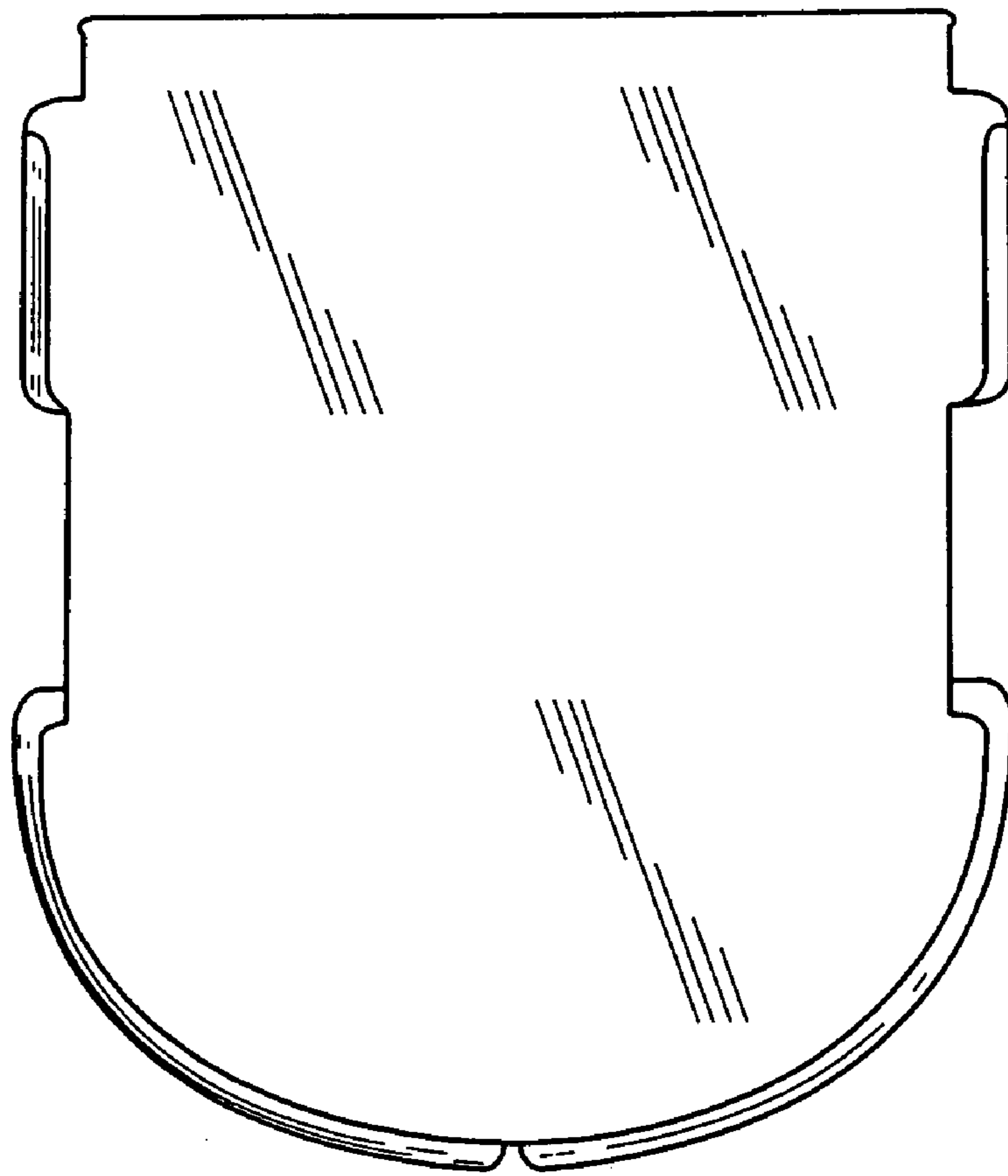

FIG. 15

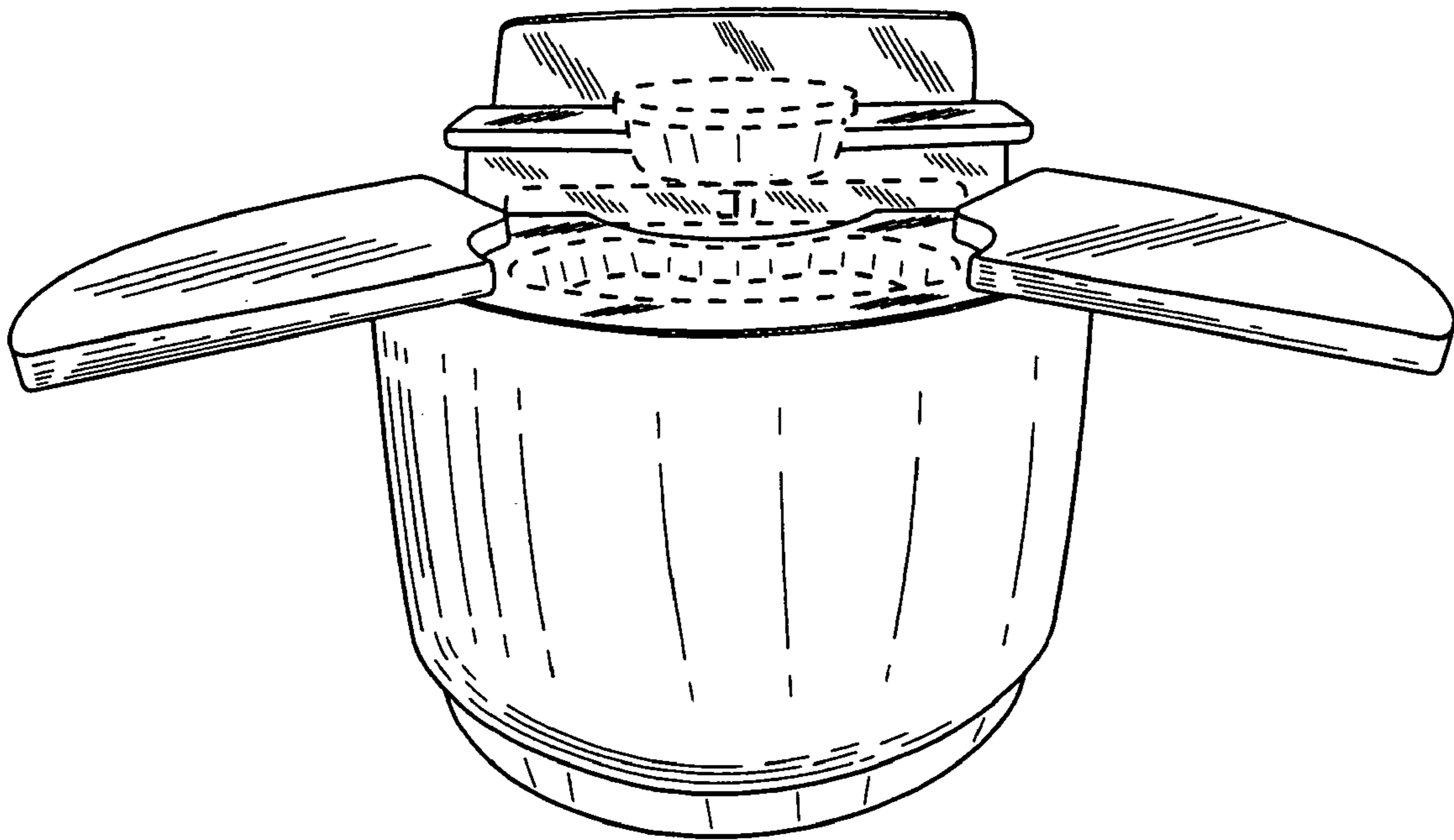

FIG. 16

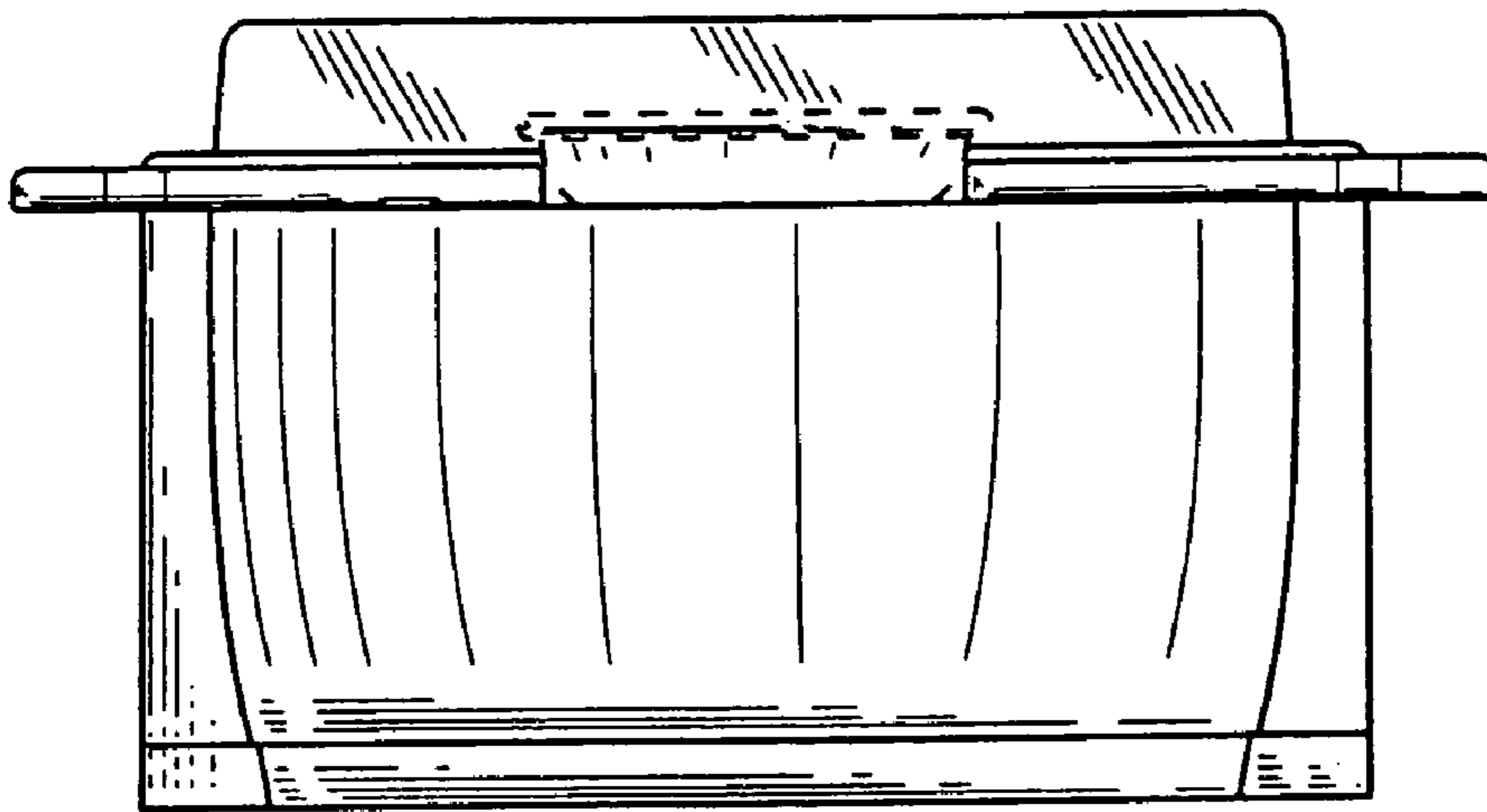

FIG. 17

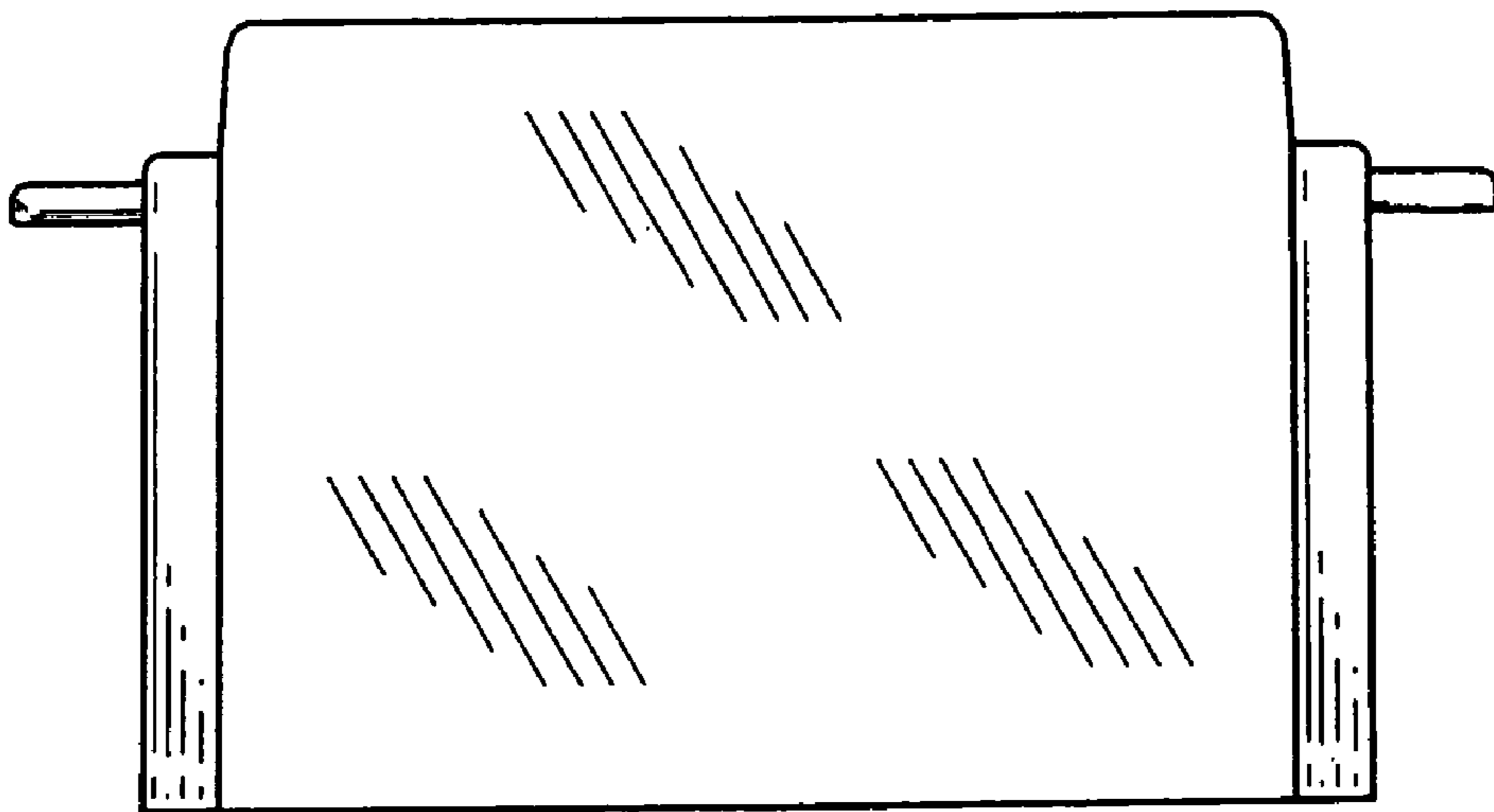

FIG. 18

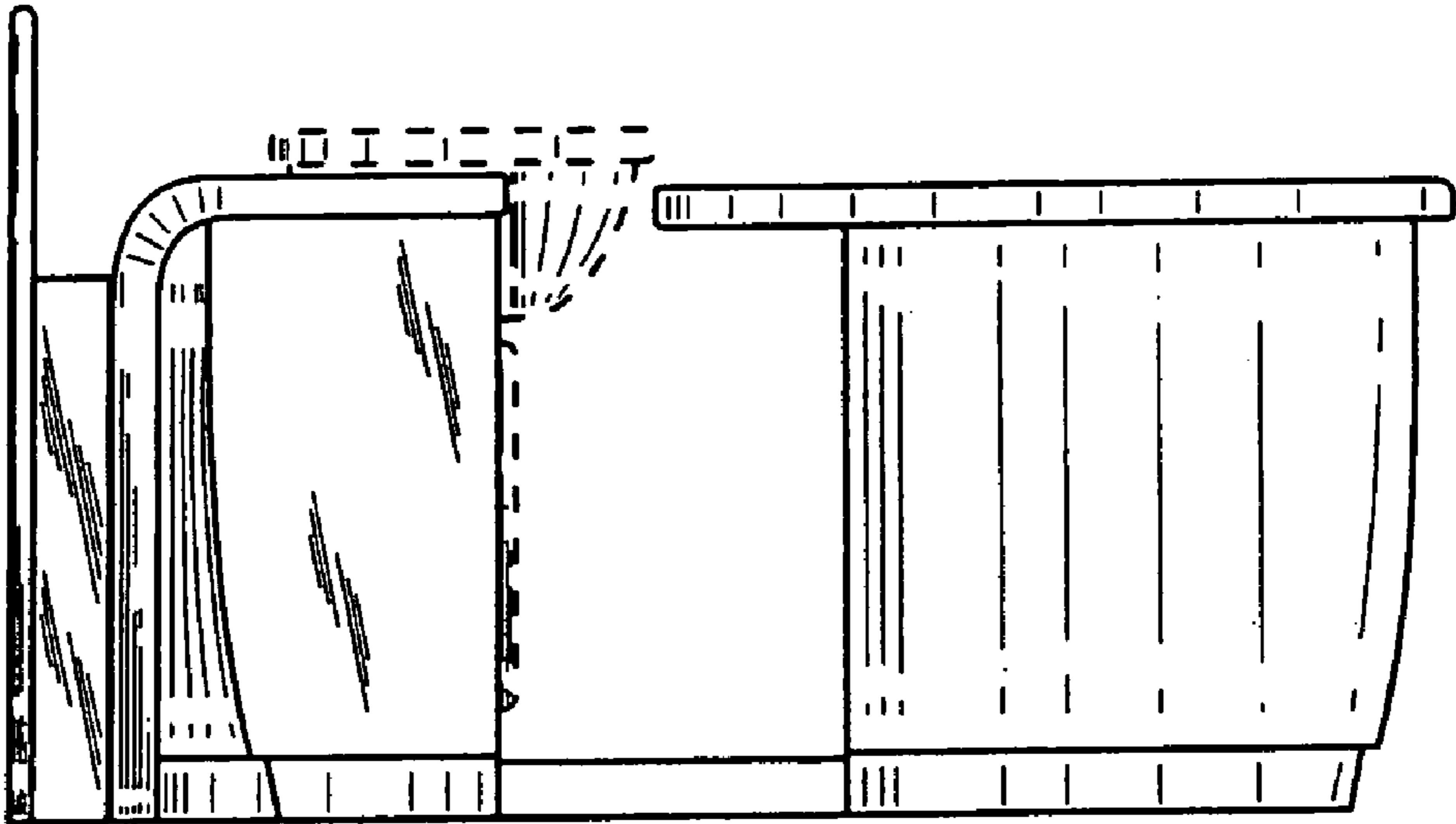

FIG. 19

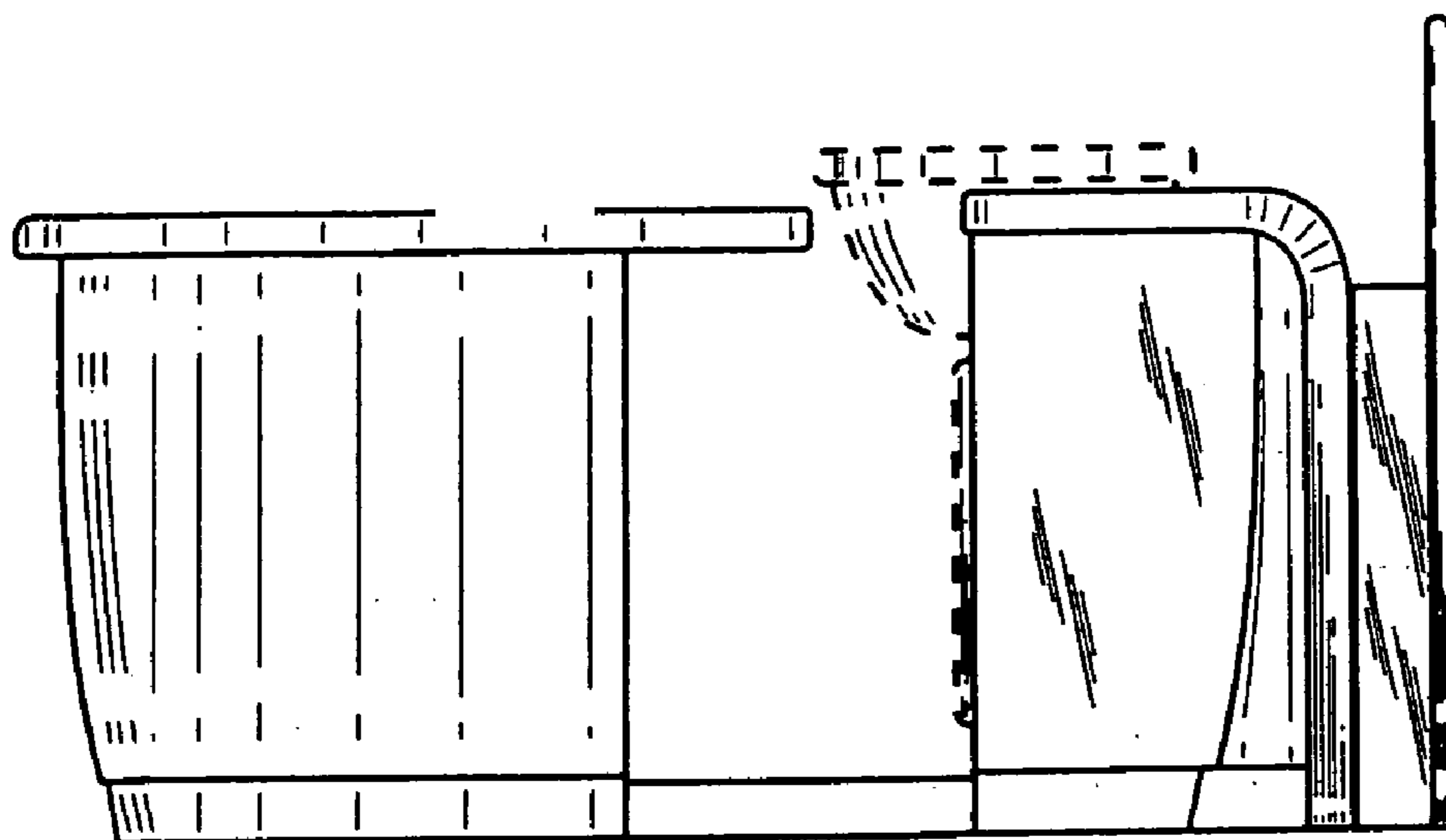

FIG. 20

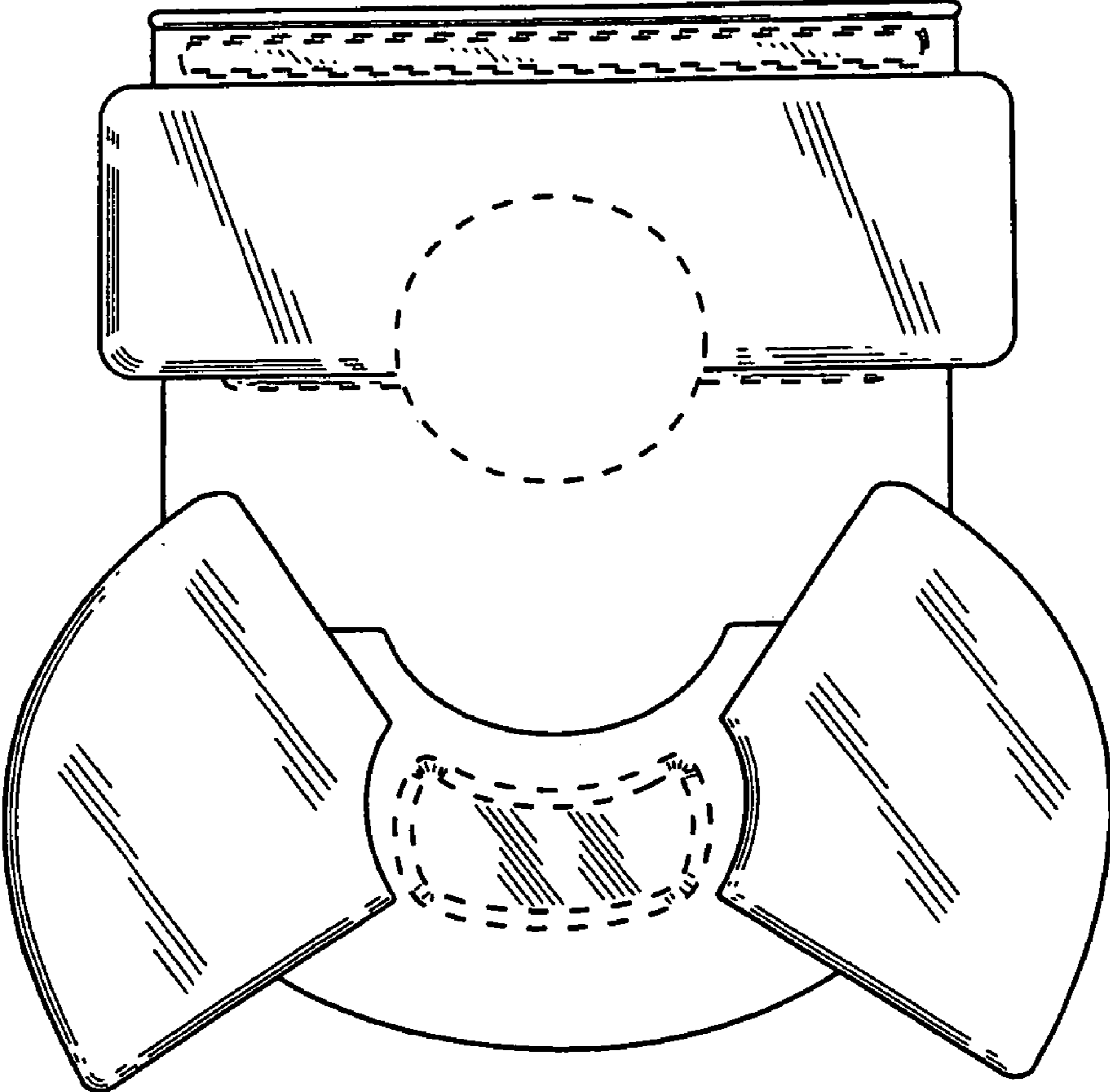
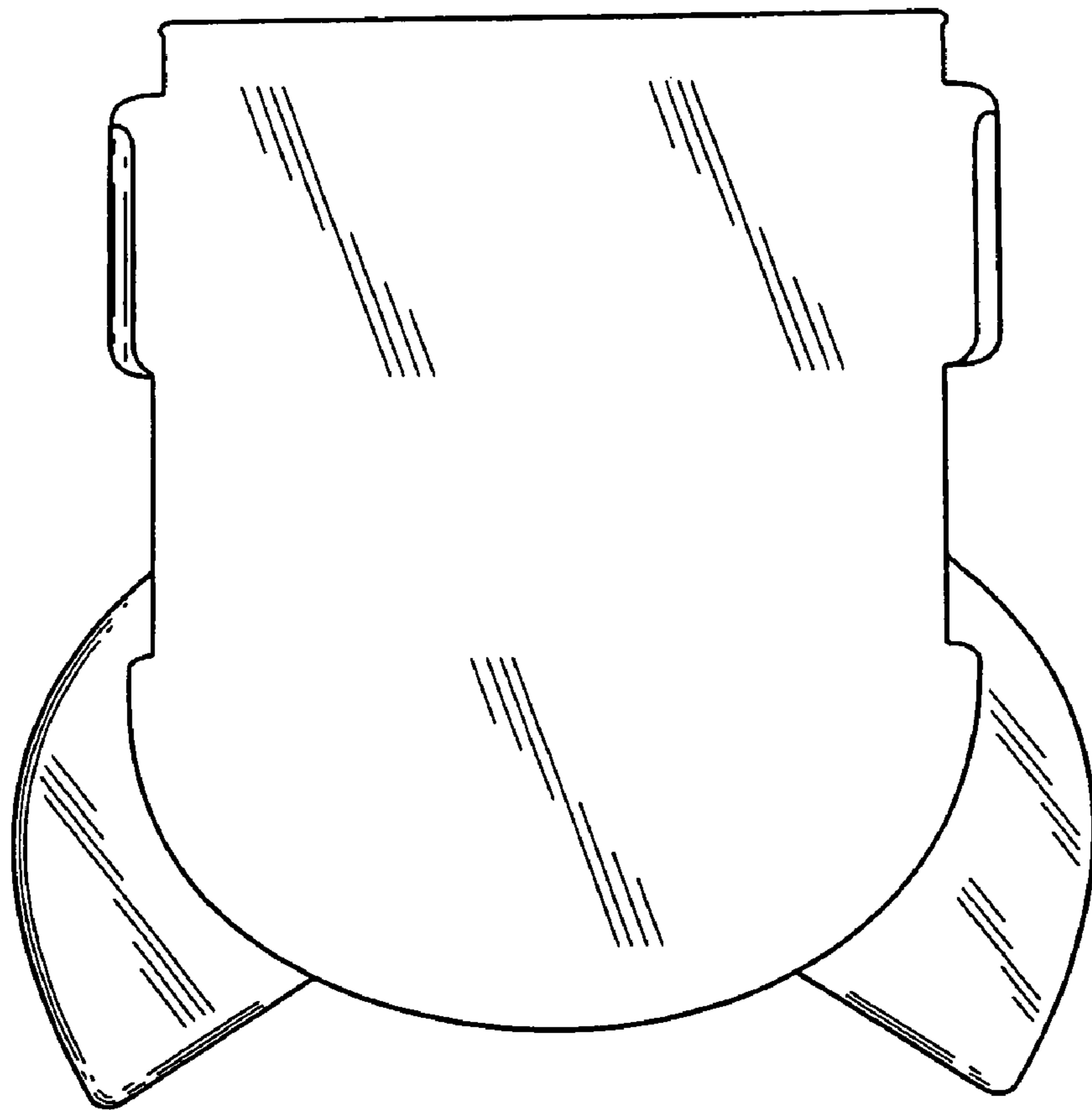

FIG. 21



UNITED STATES PATENT AND TRADEMARK OFFICE
CERTIFICATE OF CORRECTION

PATENT NO. : D587,030 S
APPLICATION NO. : 29/286690
DATED : February 24, 2009
INVENTOR(S) : Ian Scoley et al.

Page 1 of 1

It is certified that error appears in the above-identified patent and that said Letters Patent is hereby corrected as shown below:

Cover Page, under DESCRIPTION, "FIG. 1 is a perspective view of a beverage bar for an aircraft showing my new design;" should read --FIG. 1 is a perspective view of a beverage bar for an aircraft showing our new design;--

Cover Page, under DESCRIPTION, "FIG. 15 is a front perspective view of a beverage bar for an aircraft in FIG. 1 in an extended state;" should read --FIG. 15 is a front perspective view of a beverage bar for an aircraft in FIG. 8 in an extended state;--

Cover Page, under DESCRIPTION, "FIG. 21 a bottom plan view." should read --FIG. 21 is a bottom plan view.--

Cover Page under DESCRIPTION, "The broken lines shown in the drawings are for illustrative purposes only and form no part of the claim design" should read --The broken lines shown in the drawings are for illustrative purposes only and form no part of the claimed design--.

Signed and Sealed this
Thirty-first Day of May, 2011

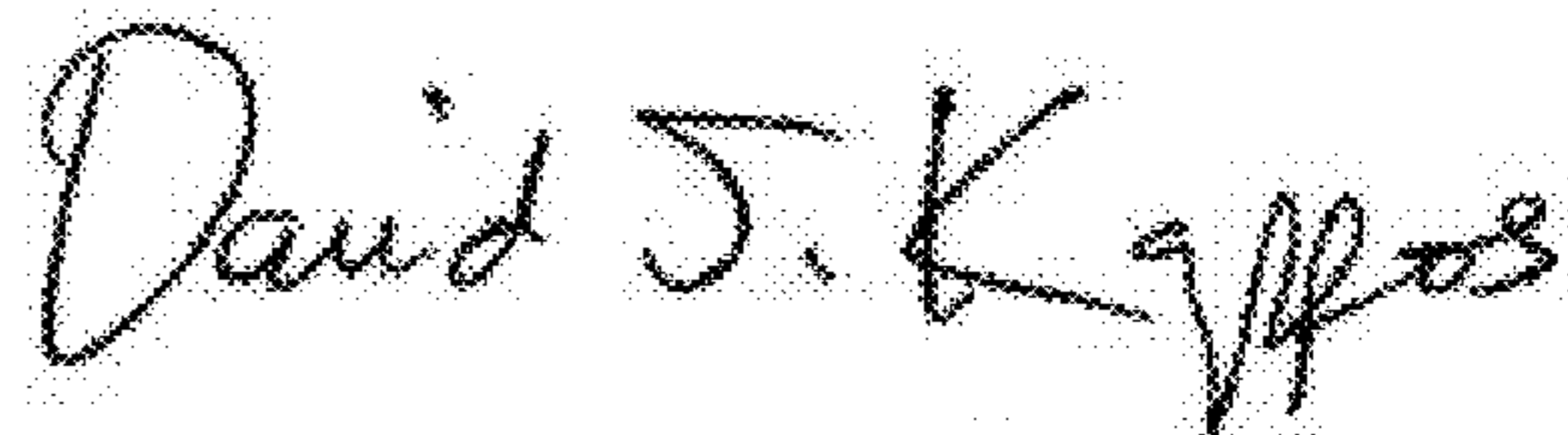

David J. Kappos
Director of the United States Patent and Trademark Office