



US00D586826S

(12) **United States Design Patent**  
**Cantrill et al.**

(10) **Patent No.:** **US D586,826 S**  
(45) **Date of Patent:** **\*\* Feb. 17, 2009**

(54) **PUMP IMPELLER**

(75) Inventors: **Garth Norman Cantrill**, Seven Hills (AU); **Ana Milian**, Quakers Hill (AU)

(73) Assignee: **Weir Minerals Australia, Ltd.**, Artarmon (AU)

(\*\*) Term: **14 Years**

(21) Appl. No.: **29/307,708**

(22) Filed: **May 6, 2008**

(30) **Foreign Application Priority Data**

Nov. 6, 2007 (AU) ..... 20655/2007

(51) **LOC (9) Cl.** ..... **15-02**

(52) **U.S. Cl.** ..... **D15/7**

(58) **Field of Classification Search** ..... D15/7-9;  
D23/231, 232, 225; 417/410.1, 359, 415-416,  
417/234, 321, 265, 405

See application file for complete search history.

(56) **References Cited**

**U.S. PATENT DOCUMENTS**

D258,588 S \* 3/1981 Sugiura ..... D15/7  
D258,589 S \* 3/1981 Sugiura ..... D15/7  
D268,112 S \* 3/1983 Sugiura ..... D15/7  
D382,881 S \* 8/1997 Hoglund et al. .... D15/7

D443,281 S \* 6/2001 Sodergard ..... D15/7  
D494,192 S \* 8/2004 Hirakawa et al. .... D15/7  
D507,578 S \* 7/2005 Hirakawa et al. .... D15/7  
D514,125 S \* 1/2006 Cook ..... D15/7  
D514,126 S \* 1/2006 Tansley et al. .... D15/7  
D554,150 S \* 10/2007 Fausett et al. .... D15/5

\* cited by examiner

*Primary Examiner*—R. Seifert

(74) *Attorney, Agent, or Firm*—Morriss O'Bryant Compagni

(57) **CLAIM**

The ornamental design for the pump impeller, as shown and described herein.

**DESCRIPTION**

FIG. 1 is a perspective view of the design of the pump impeller article as shown from the drive side of the pump impeller;

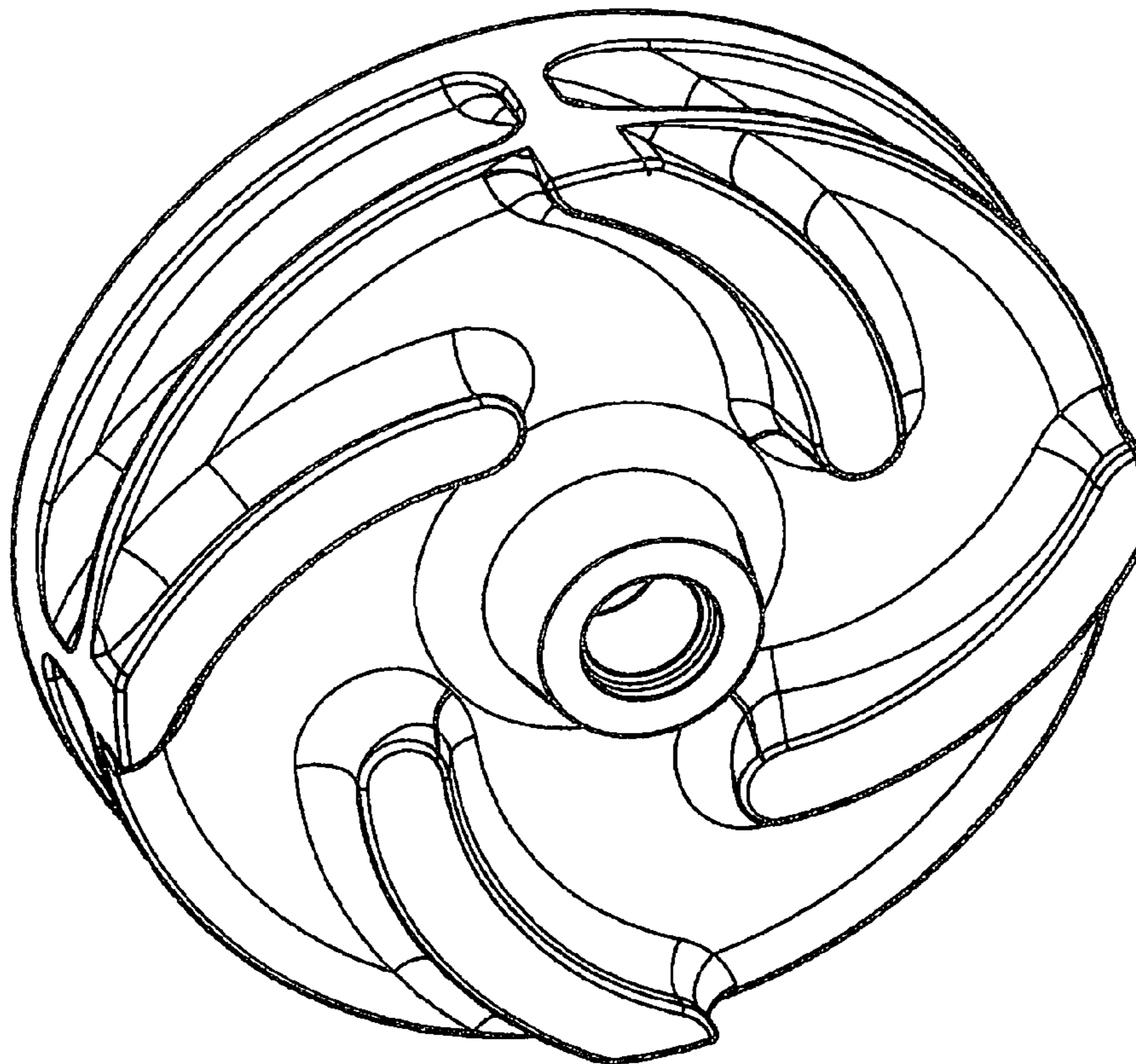
FIG. 2 is a plan view of the pump impeller looking into the drive side opening in the pump impeller;

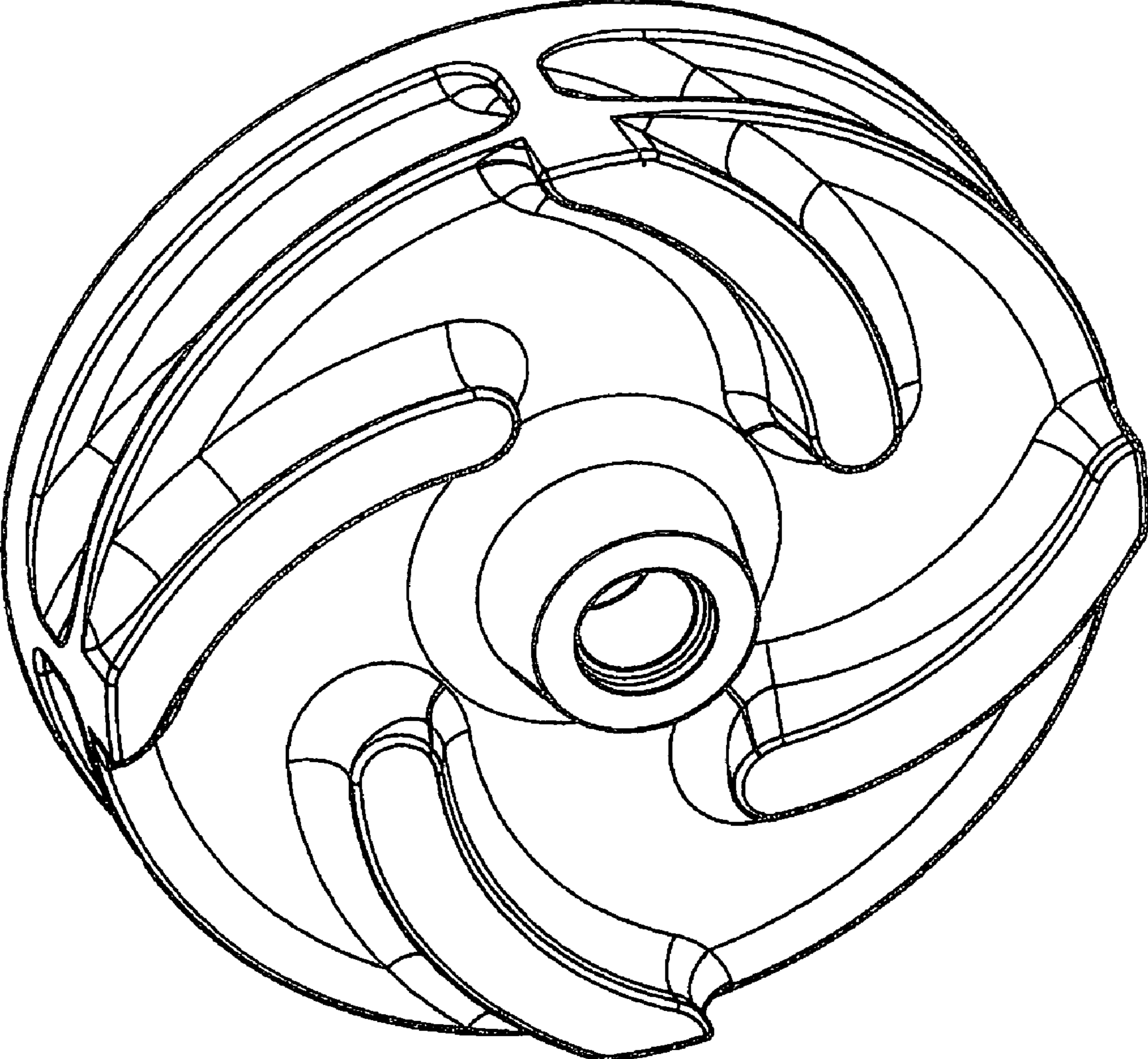
FIG. 3 is a view in elevation of the pump impeller with the drive side of the pump impeller being oriented upwardly;

FIG. 4 is a perspective view of the pump impeller as seen from the suction side of the pump impeller; and,

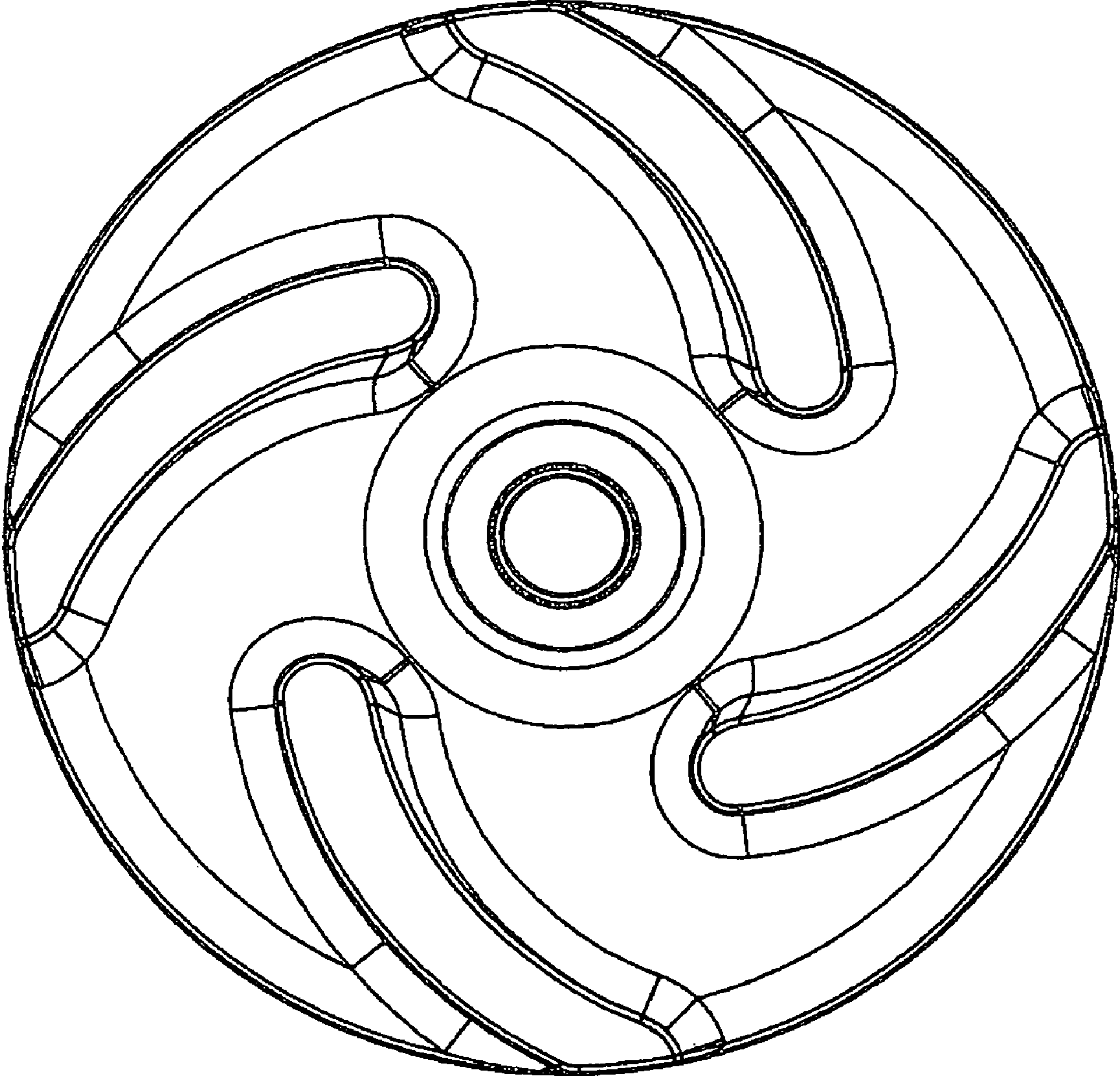
FIG. 5 is a plan view of the pump impeller as viewed looking into the suction inlet of the pump impeller.

**1 Claim, 5 Drawing Sheets**

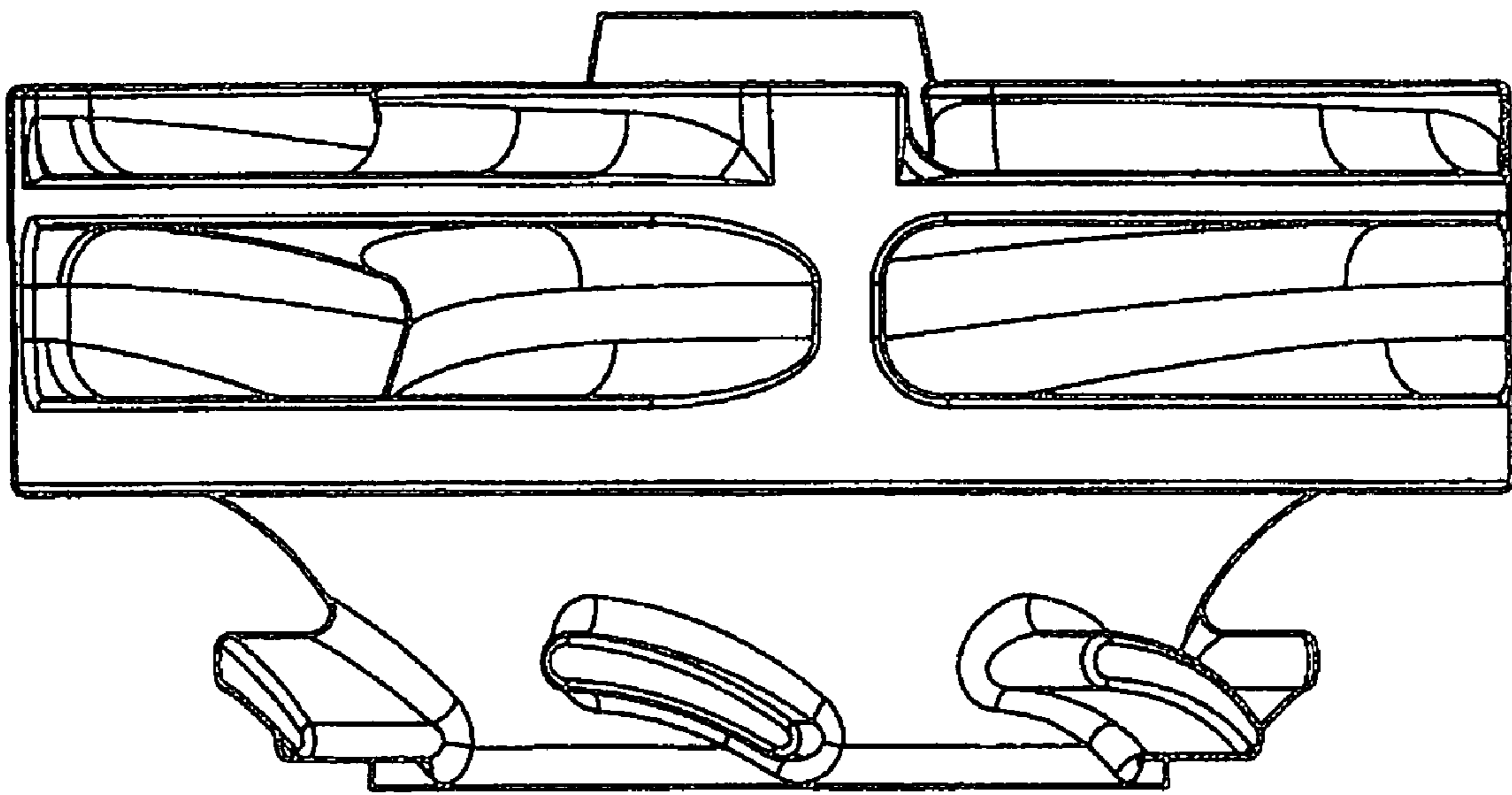




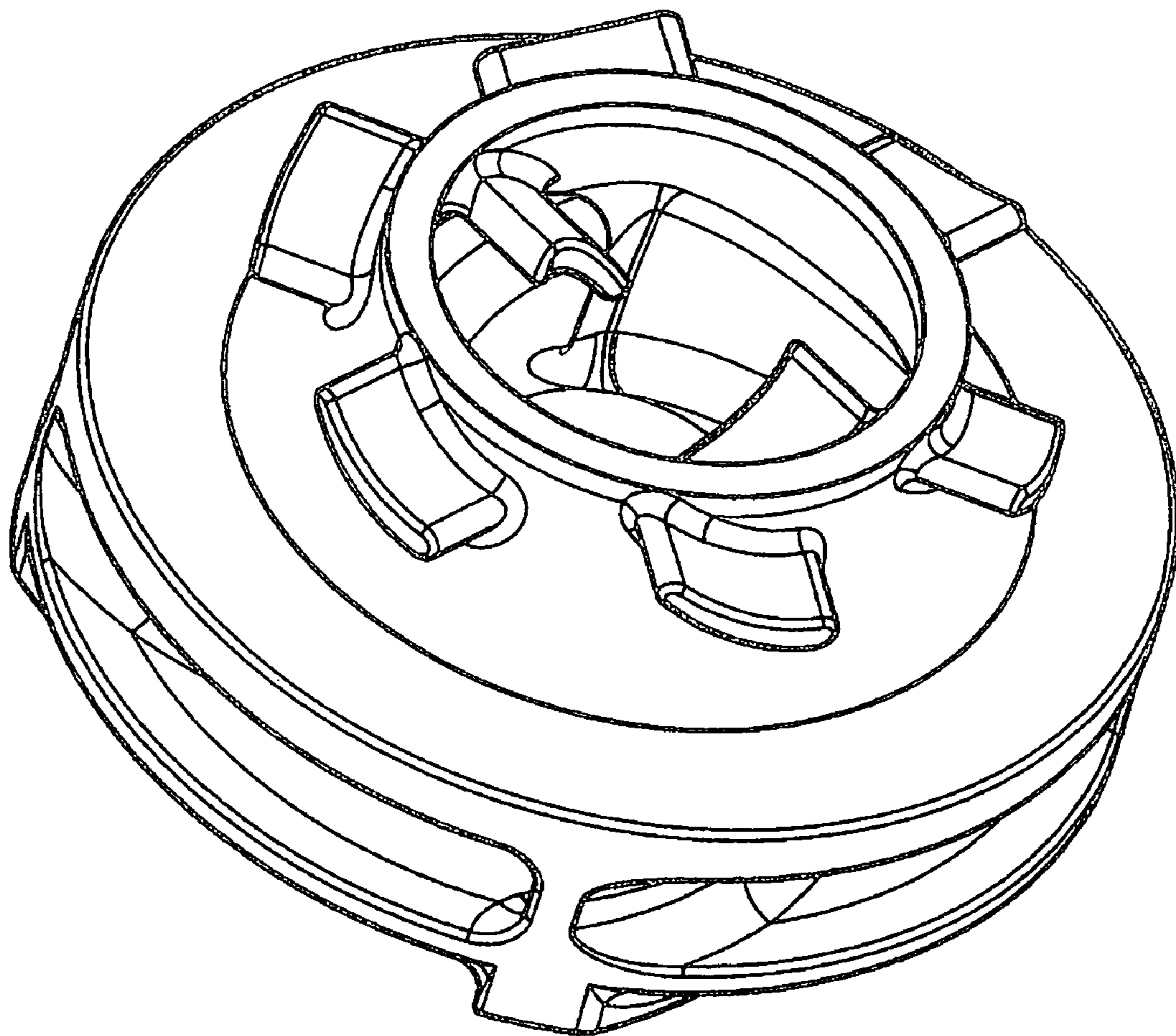
***FIG. 1***



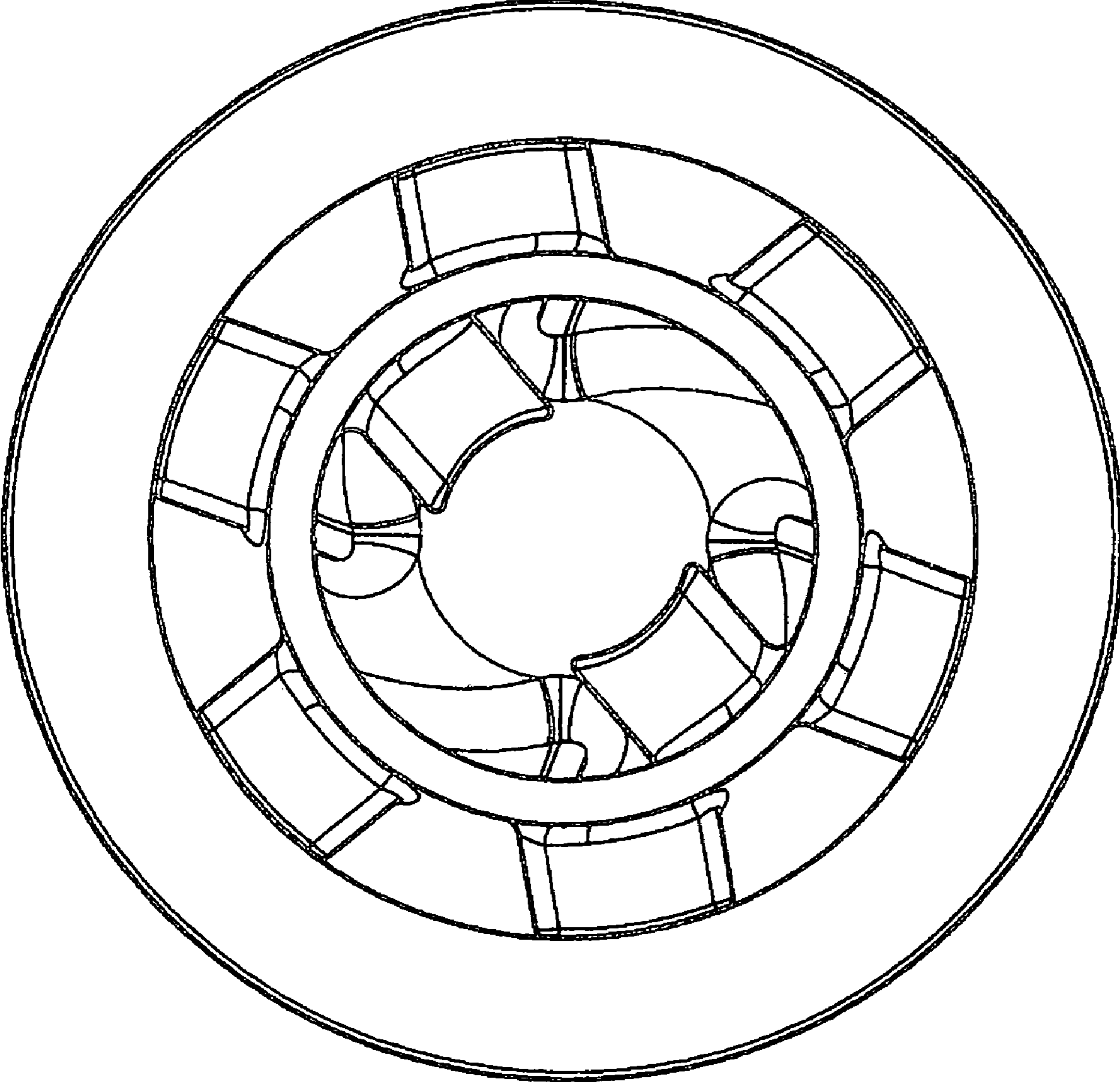
**FIG. 2**



**FIG. 3**



**FIG. 4**



**FIG. 5**