



US00D586447S

(12) **United States Design Patent**
Thomas et al.

(10) **Patent No.:** **US D586,447 S**
(45) **Date of Patent:** **** Feb. 10, 2009**

(54) **FLUID CONNECTOR**

(75) Inventors: **Kurt Judson Thomas**, Indianapolis, IN (US); **Michael Shane Hughett**, Monrovia, IN (US); **Brian Alan Enlow**, Fishers, IN (US); **Derek Allen Brown**, Lizton, IN (US)

(73) Assignee: **Masco Corporation of Indiana**, Indianapolis, IN (US)

(**) Term: **14 Years**

(21) Appl. No.: **29/292,211**

(22) Filed: **Oct. 3, 2007**

(51) **LOC (9) Cl.** **23-02**

(52) **U.S. Cl.** **D23/303**

(58) **Field of Classification Search** D23/231, D23/249, 257, 259, 260, 261, 262, 263, 264, D23/265, 266, 267, 268, 250, 251, 252, 253, D23/254, 255, 256, 238, 239, 240, 241, 242, D23/243, 244, 245, 246, 247, 248; 4/675, 4/676, 677, 678; D8/300, 307, 308, 310, D8/311, 312, 321; D6/550; 137/801; 16/110.01, 16/441; 285/1, 53, 112, 179, 340, 367, 373, 285/404, 915

See application file for complete search history.

(56) **References Cited**

U.S. PATENT DOCUMENTS

4,316,870 A 2/1982 Rowley

(Continued)

OTHER PUBLICATIONS

Anchor end fitting, at least as early as Oct. 3, 2007.

(Continued)

Primary Examiner—T. Chase Nelson

Assistant Examiner—Michael A Pratt

(74) *Attorney, Agent, or Firm*—Leon E. Redman; Baker & Daniels LLP

(57) **CLAIM**

The ornamental design for a fluid connector, as shown and described.

DESCRIPTION

FIG. 1 is a perspective view of a first embodiment the fluid connector of the present design application; the break lines in the fluid connector body are shown to represent unspecified length

FIG. 2 is a front elevational view of the fluid connector of FIG. 1;

FIG. 3 is a rear elevational view of the fluid connector of FIG. 1;

FIG. 4 is a left side elevational view of the fluid connector of FIG. 1;

FIG. 5 is a right side elevational view of the fluid connector of FIG. 1;

FIG. 6 is a top plan view of the fluid connector of FIG. 1;

FIG. 7 is a bottom plan view of the fluid connector of FIG. 1;

FIG. 8 is a perspective view of the second embodiment of the fluid connector of FIG. 1, with portions shown in broken lines; the break lines are shown to represent unspecified length

FIG. 9 is a front elevational view of the fluid connector of FIG. 8;

FIG. 10 is a rear elevational view of the fluid connector of FIG. 8;

FIG. 11 is a left side elevational view of the fluid connector of FIG. 8;

FIG. 12 is a right side elevational view of the fluid connector of FIG. 8;

FIG. 13 is a top plan view of the fluid connector of FIG. 8; and,

FIG. 14 is a bottom plan view of the fluid connector of FIG. 8.

The broken lines in FIGS. 8–14 illustrated portions of the fluid connector that form no part of the claimed design. The design is shown broken away in order to indicate that a specific length of fluid connector also forms no part of the claimed design.

1 Claim, 8 Drawing Sheets

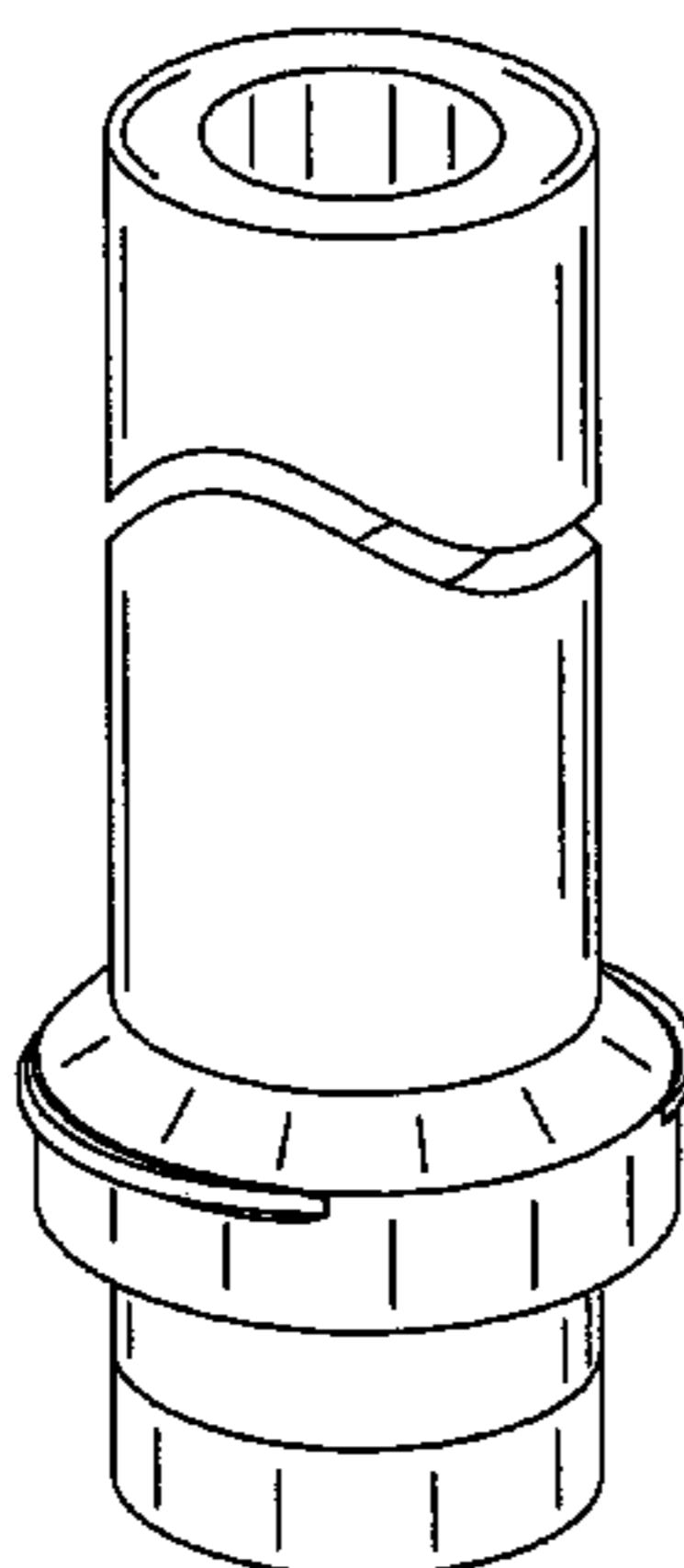

US D586,447 S

Page 2

U.S. PATENT DOCUMENTS

4,446,084	A	5/1984	Rowley	6,838,041	B2	1/2005	Rowley
4,525,136	A	6/1985	Rowley	6,848,719	B2	2/2005	Rowley
4,664,423	A	5/1987	Rowley	6,860,524	B1	3/2005	Rowley
4,803,033	A	2/1989	Rowley	6,902,210	B1	6/2005	Rowley
5,060,689	A *	10/1991	Csaszar et al. 285/93	7,213,845	B2	5/2007	Sato et al.
5,527,503	A	6/1996	Rowley	7,252,117	B1	8/2007	Glenn
5,622,670	A	4/1997	Rowley	2002/0100139	A1	8/2002	Rowley
5,741,458	A	4/1998	Rowley	2004/0080160	A1 *	4/2004	Rief 285/276
5,756,023	A	5/1998	Stachowiak	2004/0150132	A1	8/2004	Rowley
5,833,279	A	11/1998	Rowley	2006/0082145	A1 *	4/2006	Steveley 285/305
5,861,200	A	1/1999	Rowley	2006/0108705	A1	5/2006	Rowley
5,895,695	A	4/1999	Rowley	2006/0145475	A1 *	7/2006	Walker et al. 285/319
5,964,484	A *	10/1999	Bartholomew 285/319	2006/0170134	A1	8/2006	Rowley et al.
6,012,743	A	1/2000	Godeau et al.	2007/0271695	A1	11/2007	Thomas et al.
6,070,916	A	6/2000	Rowley	2008/0178950	A1	7/2008	Marty et al.
6,082,780	A	7/2000	Rowley et al.	2008/0178957	A1	7/2008	Thomas et al.
6,270,125	B1	8/2001	Rowley et al.				
6,287,501	B1	9/2001	Rowley				
6,485,666	B1	11/2002	Rowley				
6,557,907	B2	5/2003	Rowley				
6,672,628	B2	1/2004	Thomas et al.				
6,783,160	B2	8/2004	Rowley				

OTHER PUBLICATIONS

BrassCraft® Innoflex™ brochure, "Bathroom beauty now comes uncoiled. Flexible, Durable, Beautiful," Apr. 2007, 4 pgs.
OateyPEX® by MerFlex®, May 2005, 6 pages, Oatey Company, Cleveland, Ohio.

* cited by examiner

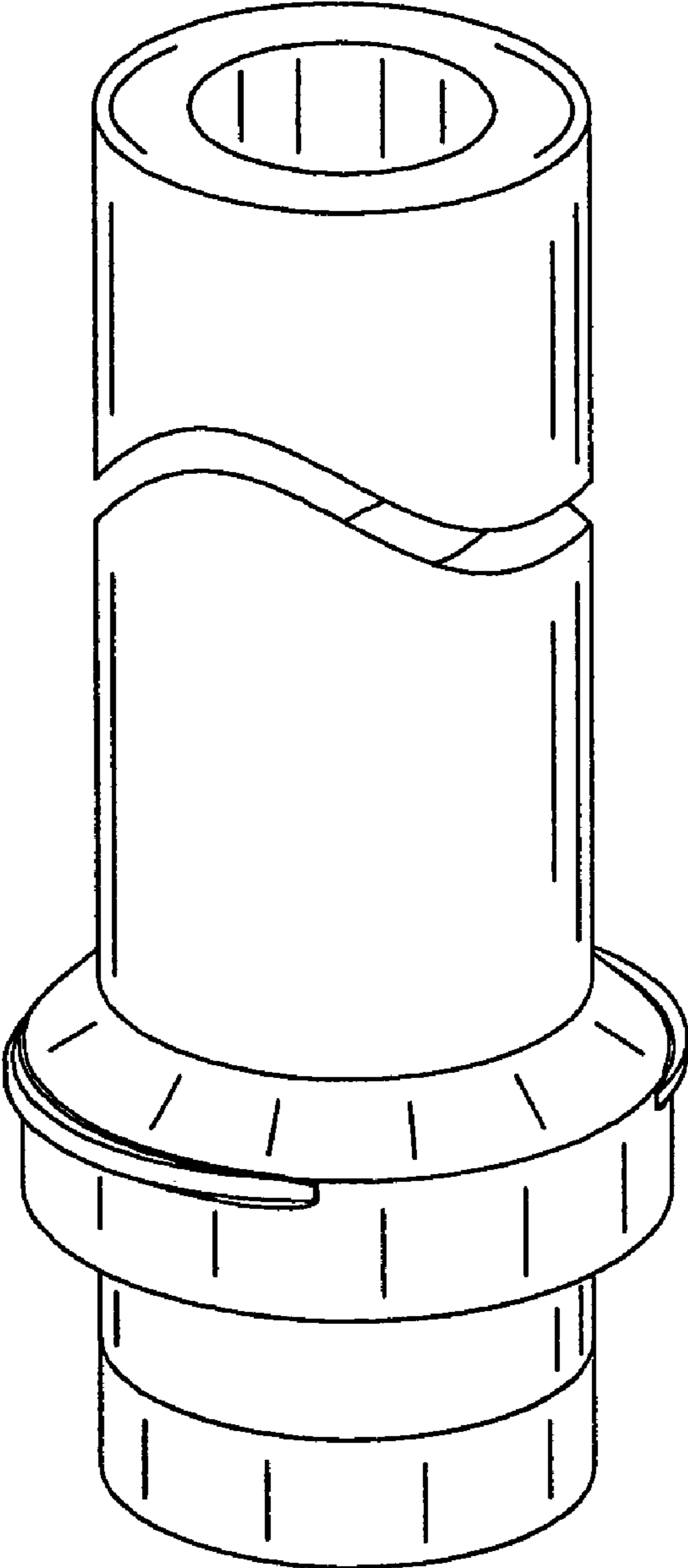

FIG. 1

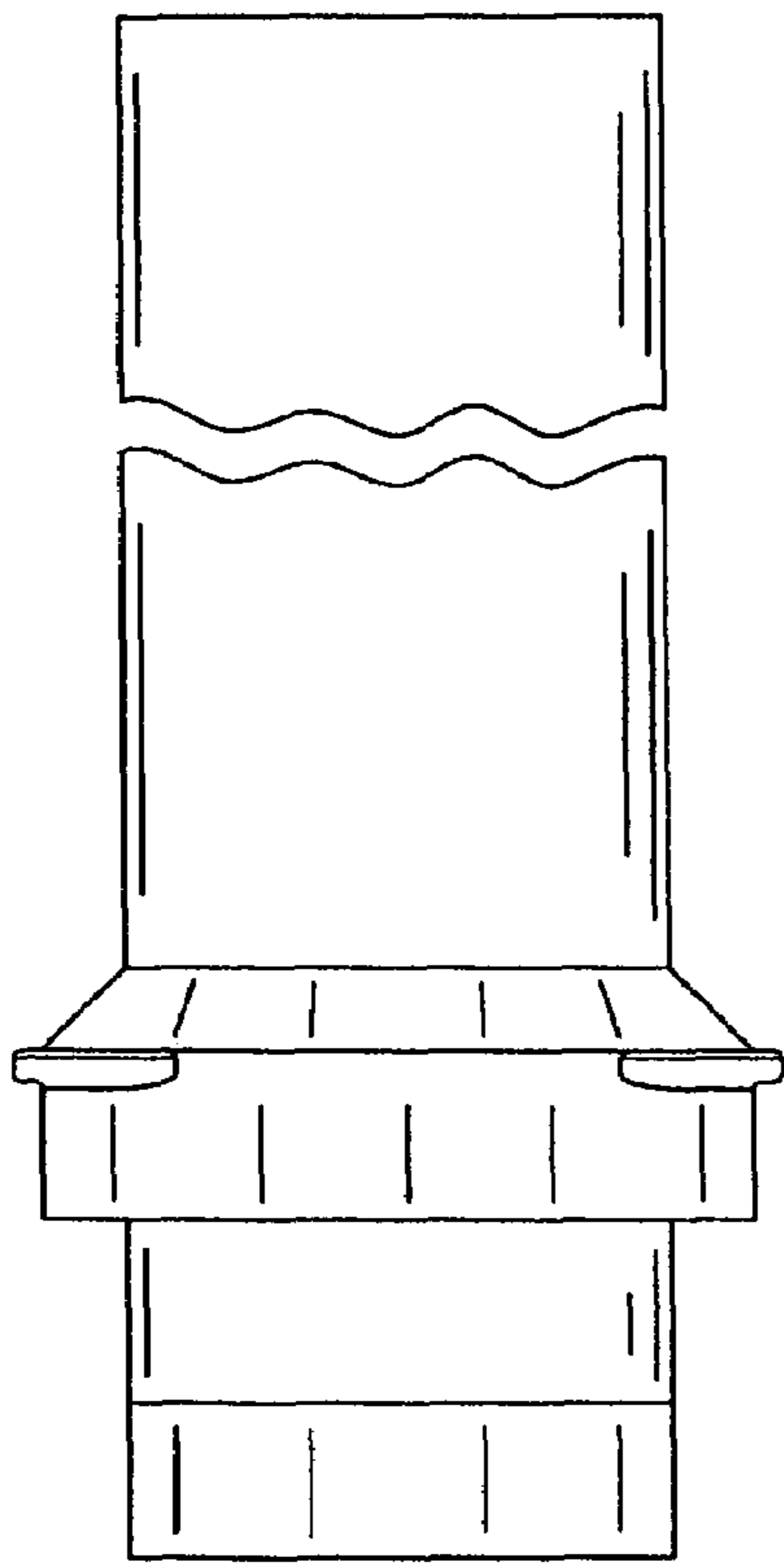

FIG. 2

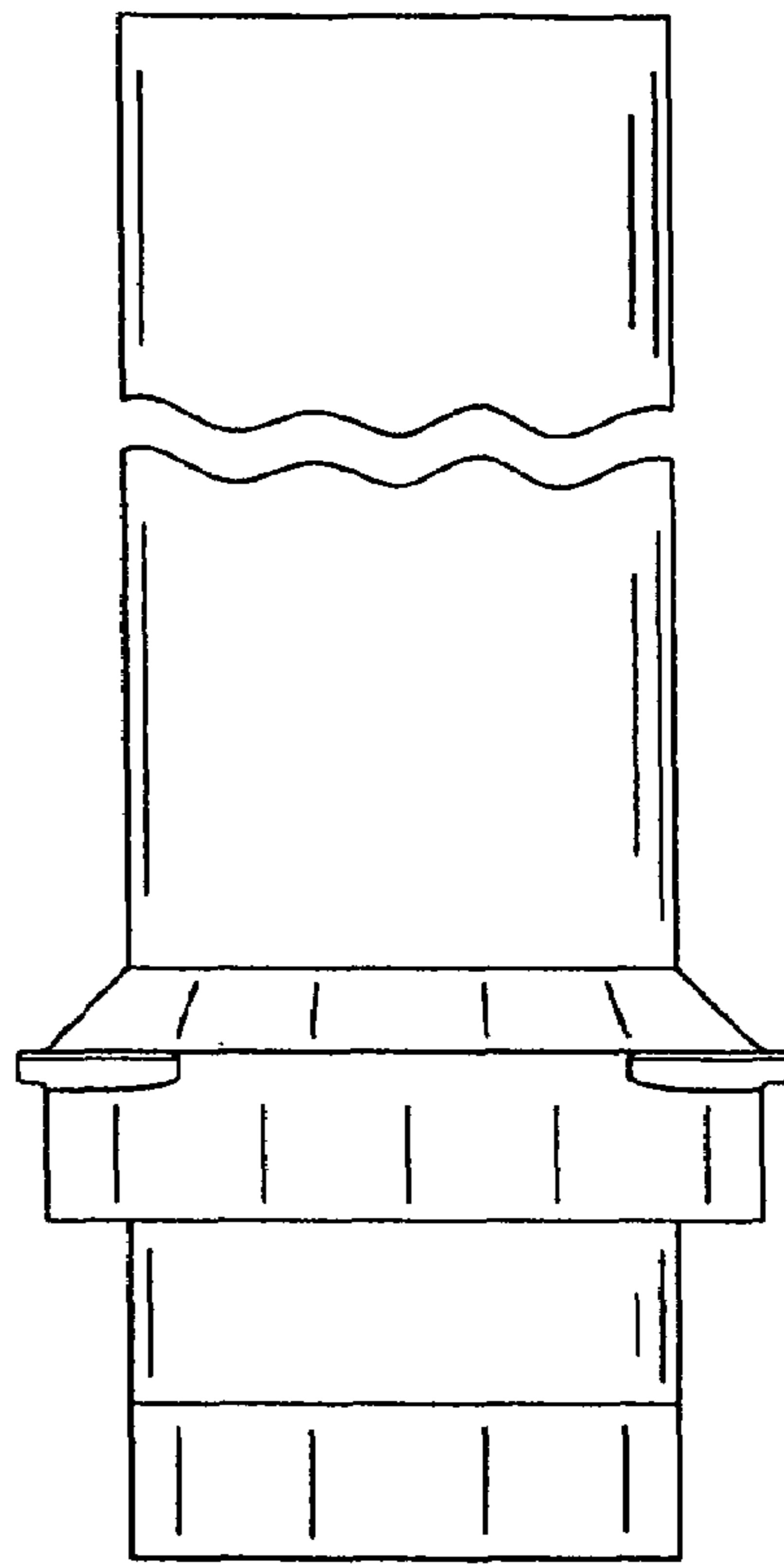

FIG. 3

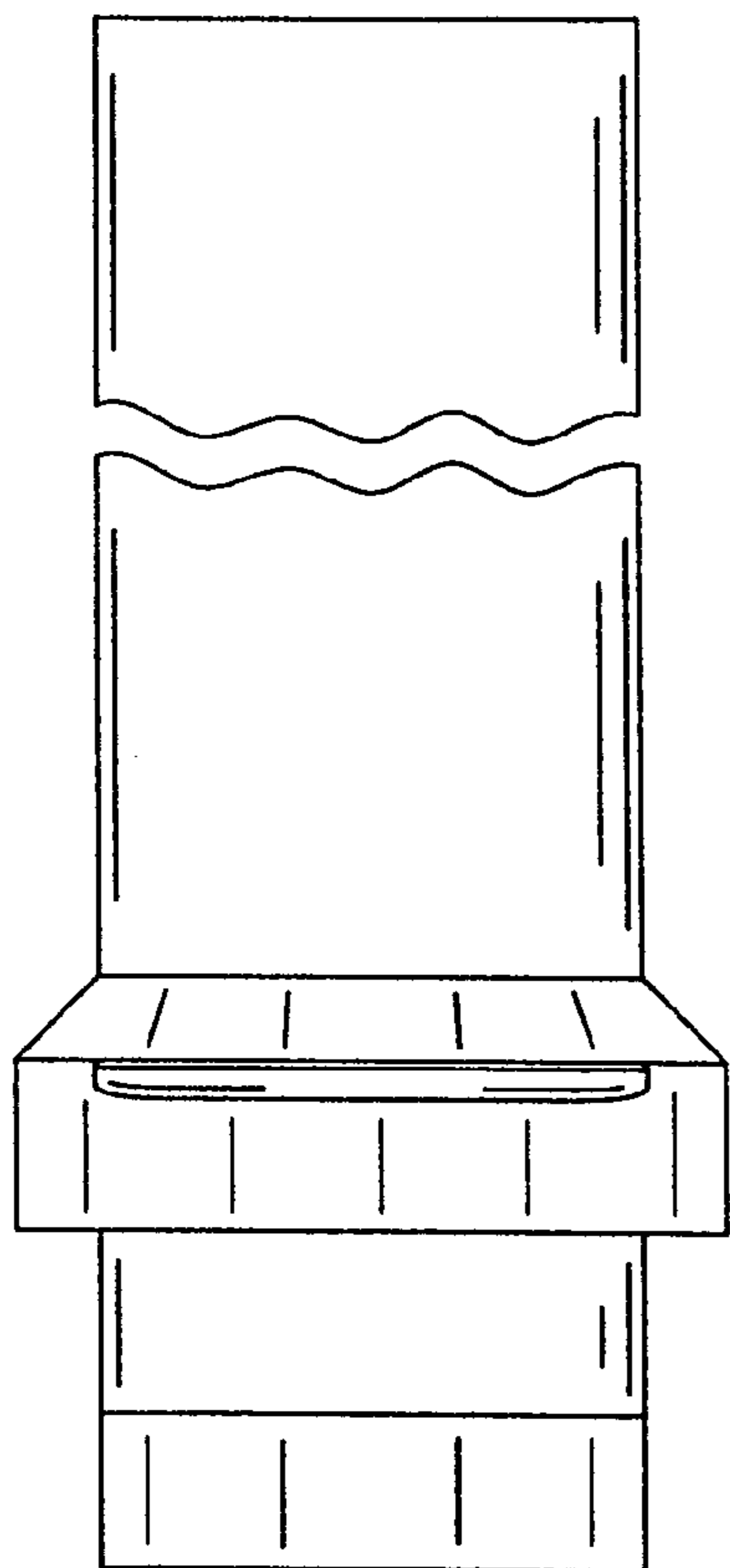

FIG. 4

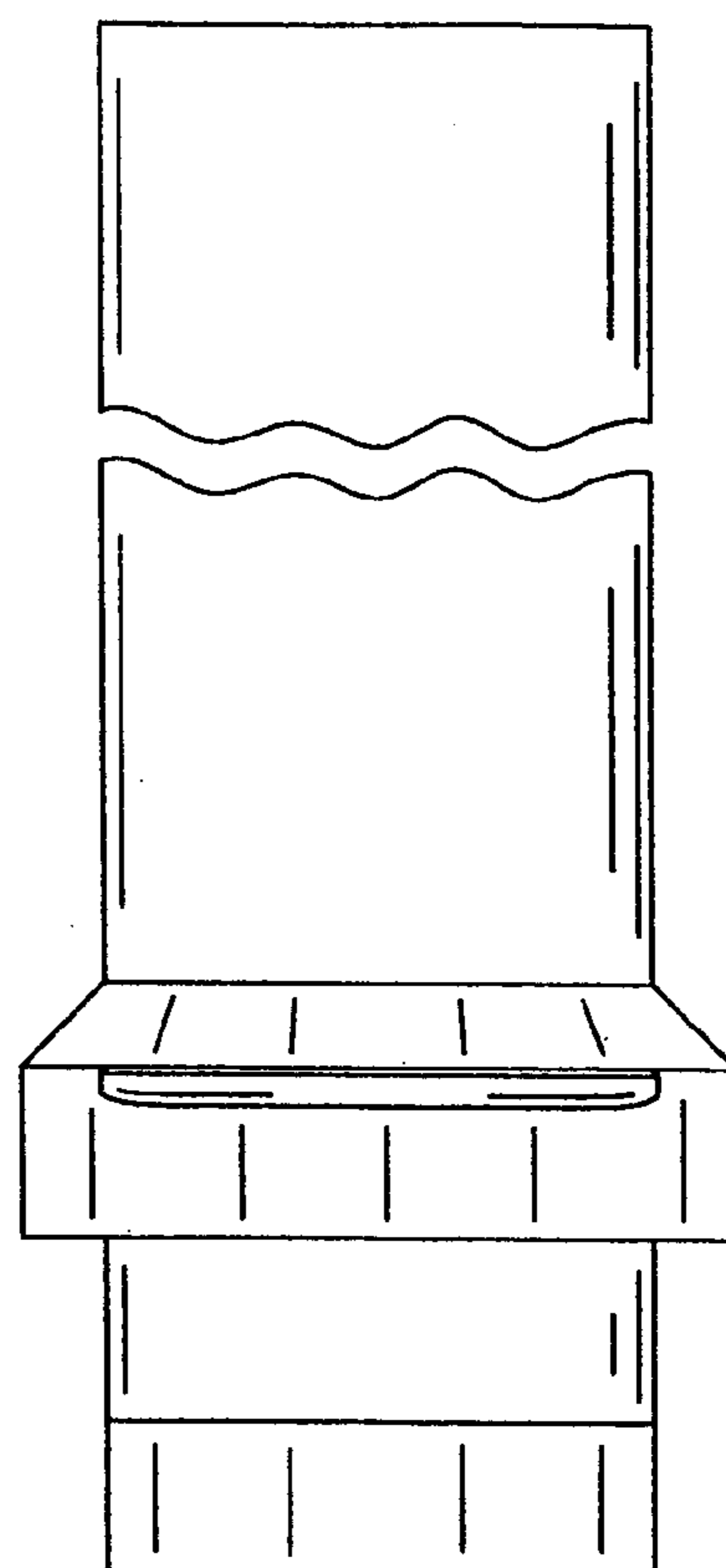

FIG. 5

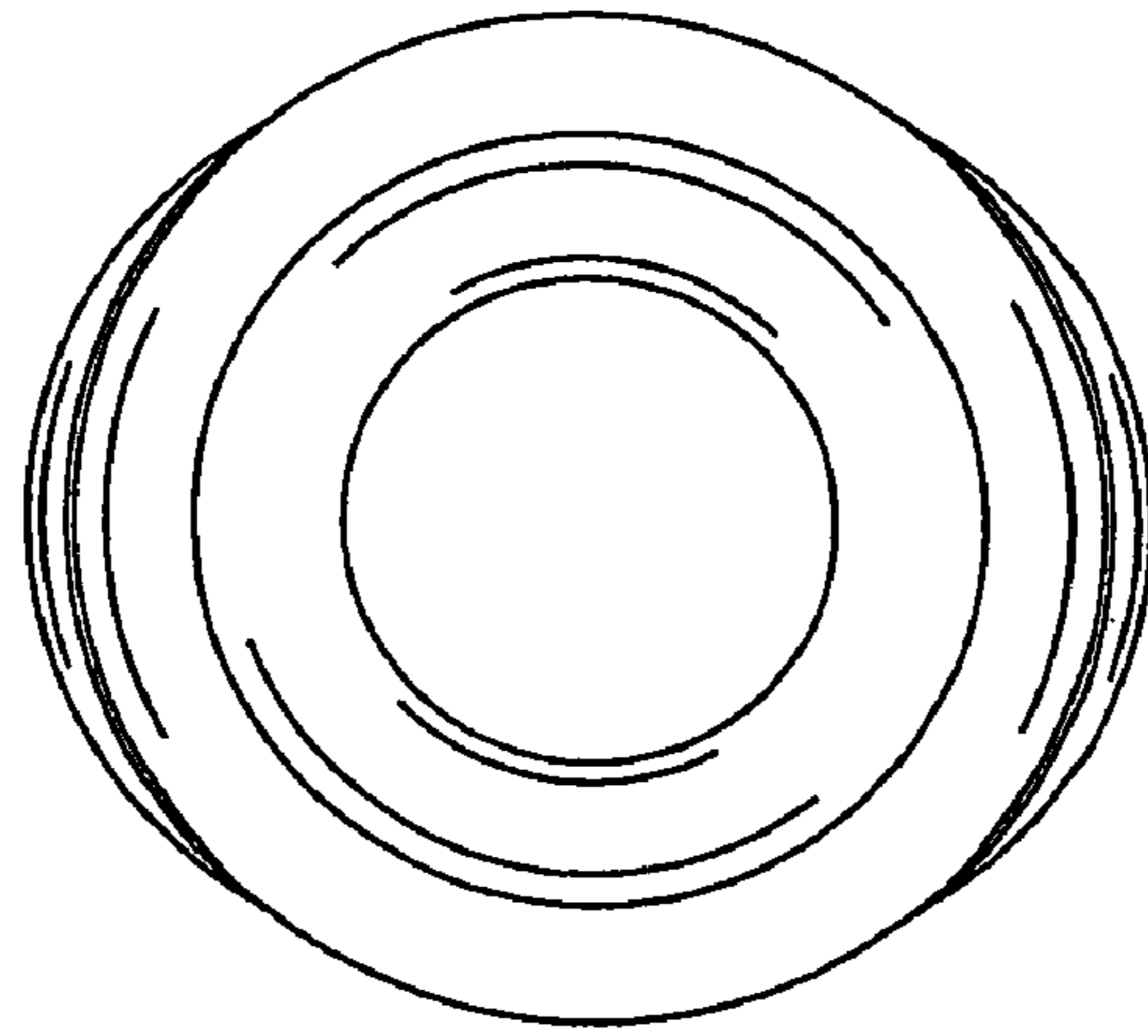

FIG. 6

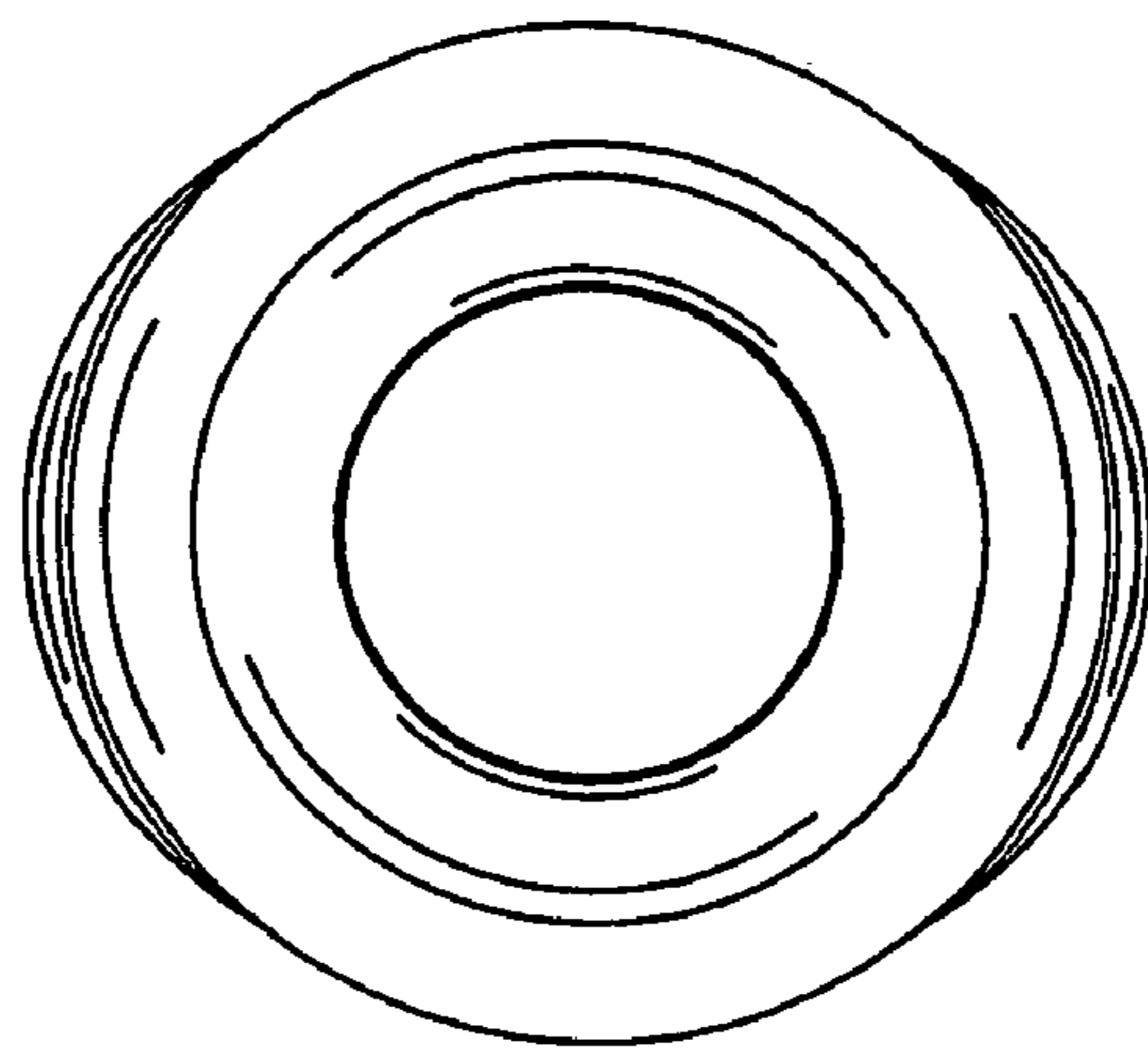

FIG. 7

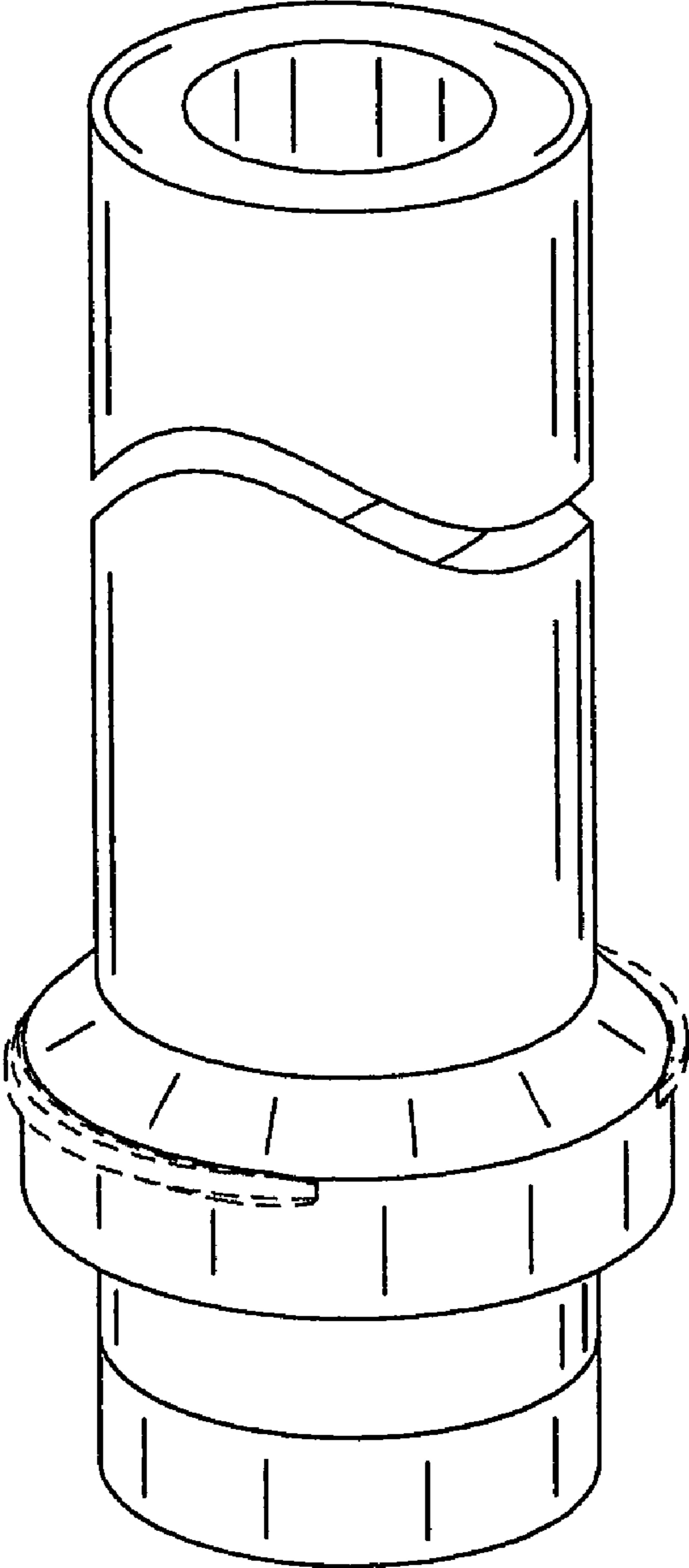

FIG. 8

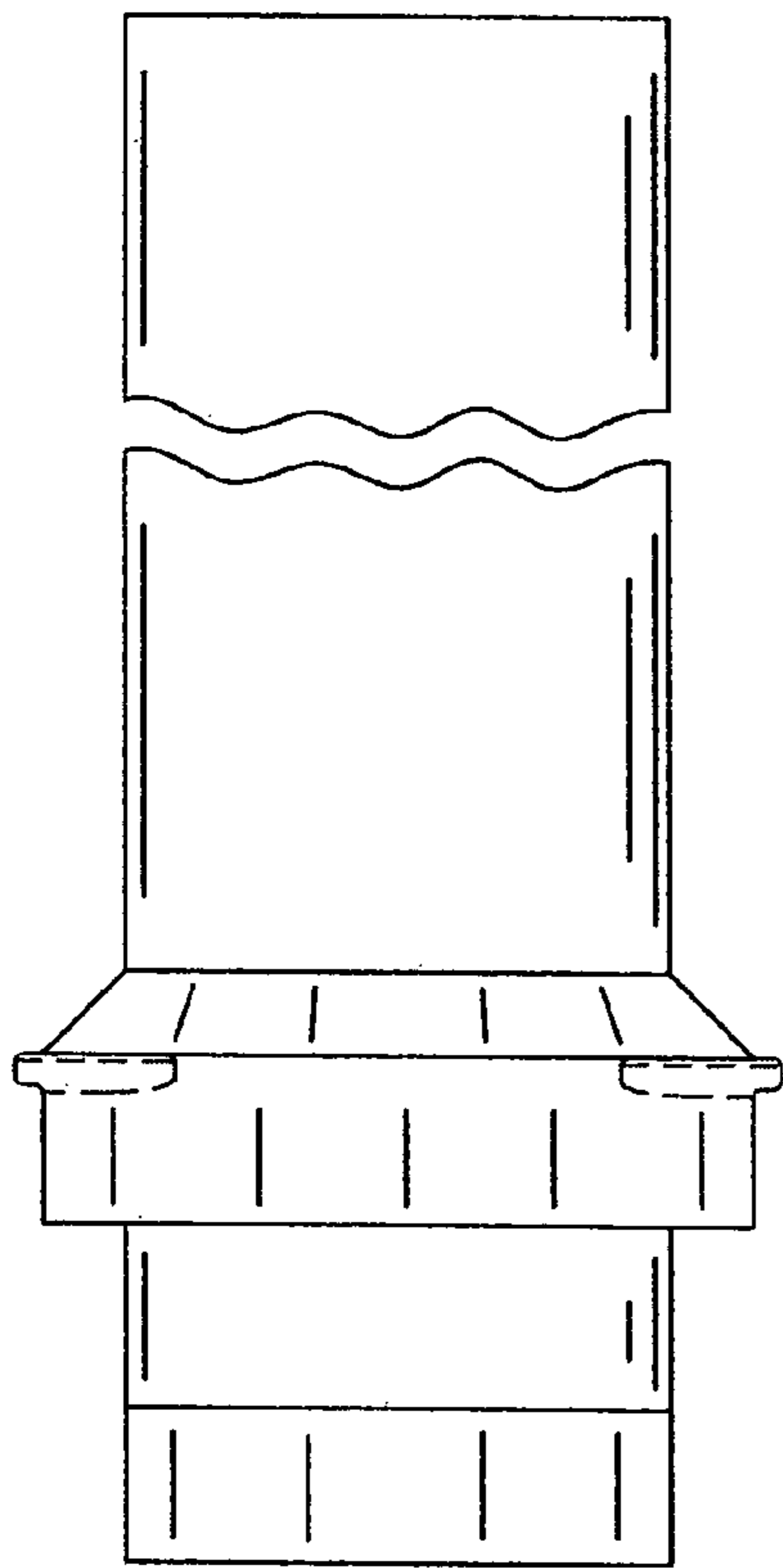

FIG. 9

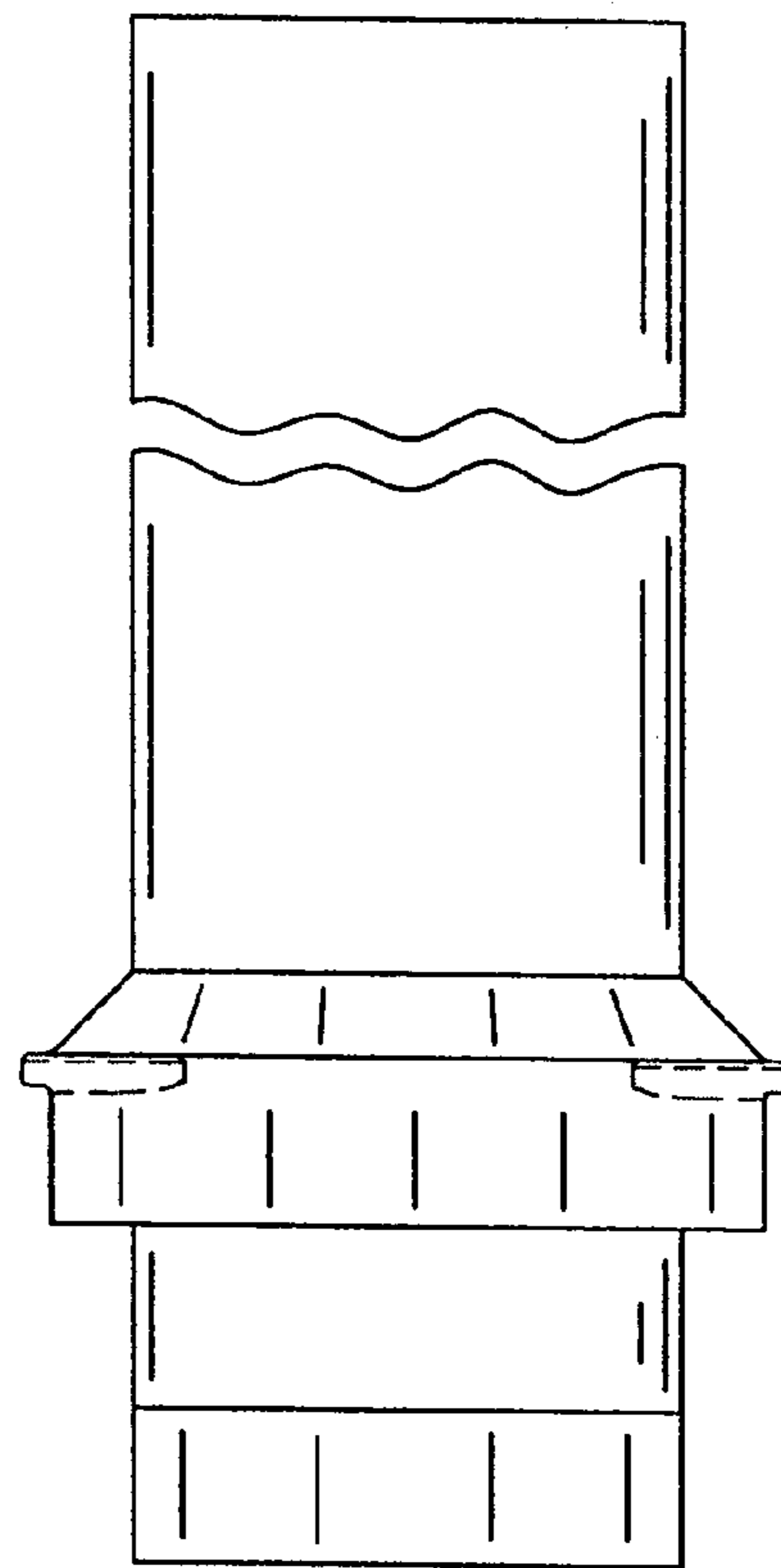

FIG. 10

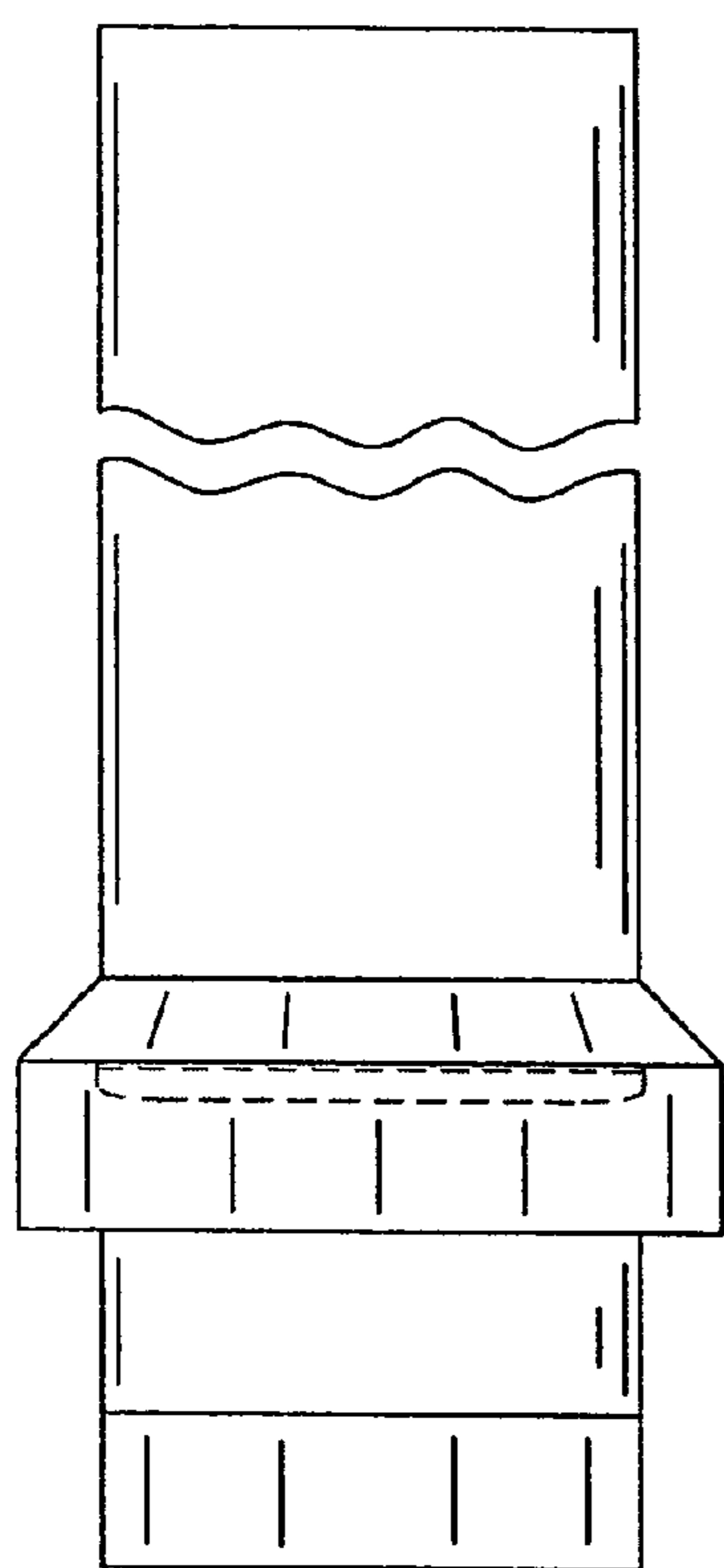

FIG. 11

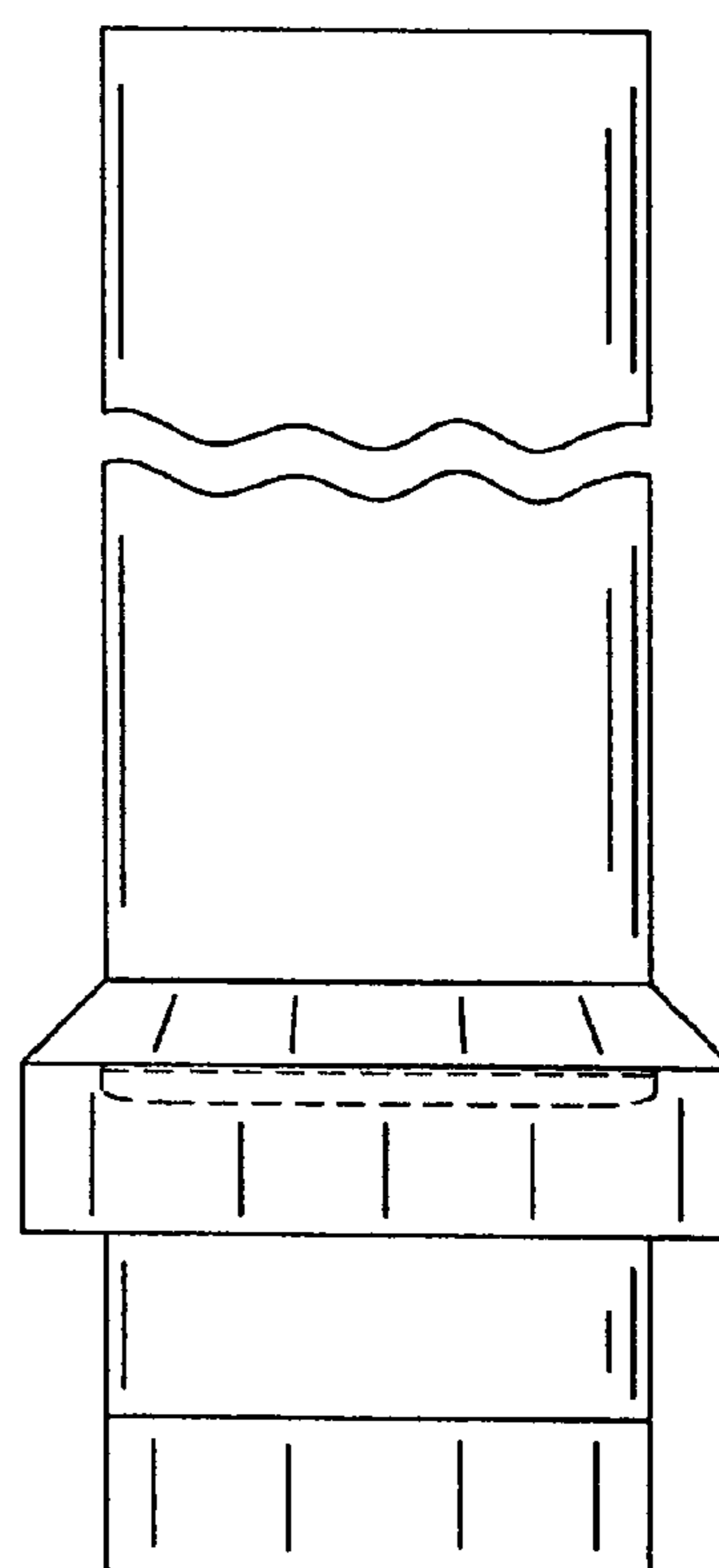

FIG. 12

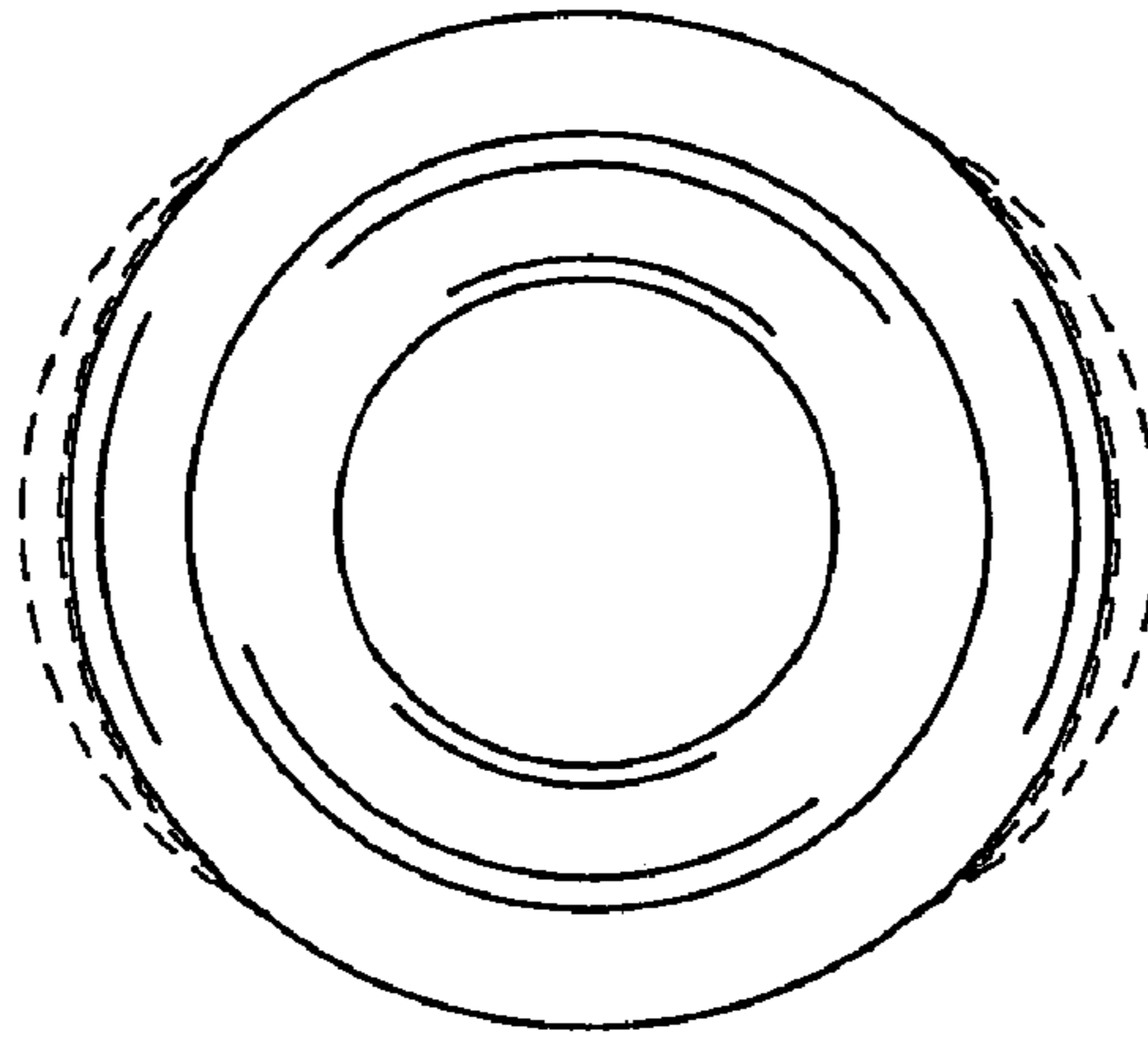

FIG. 13

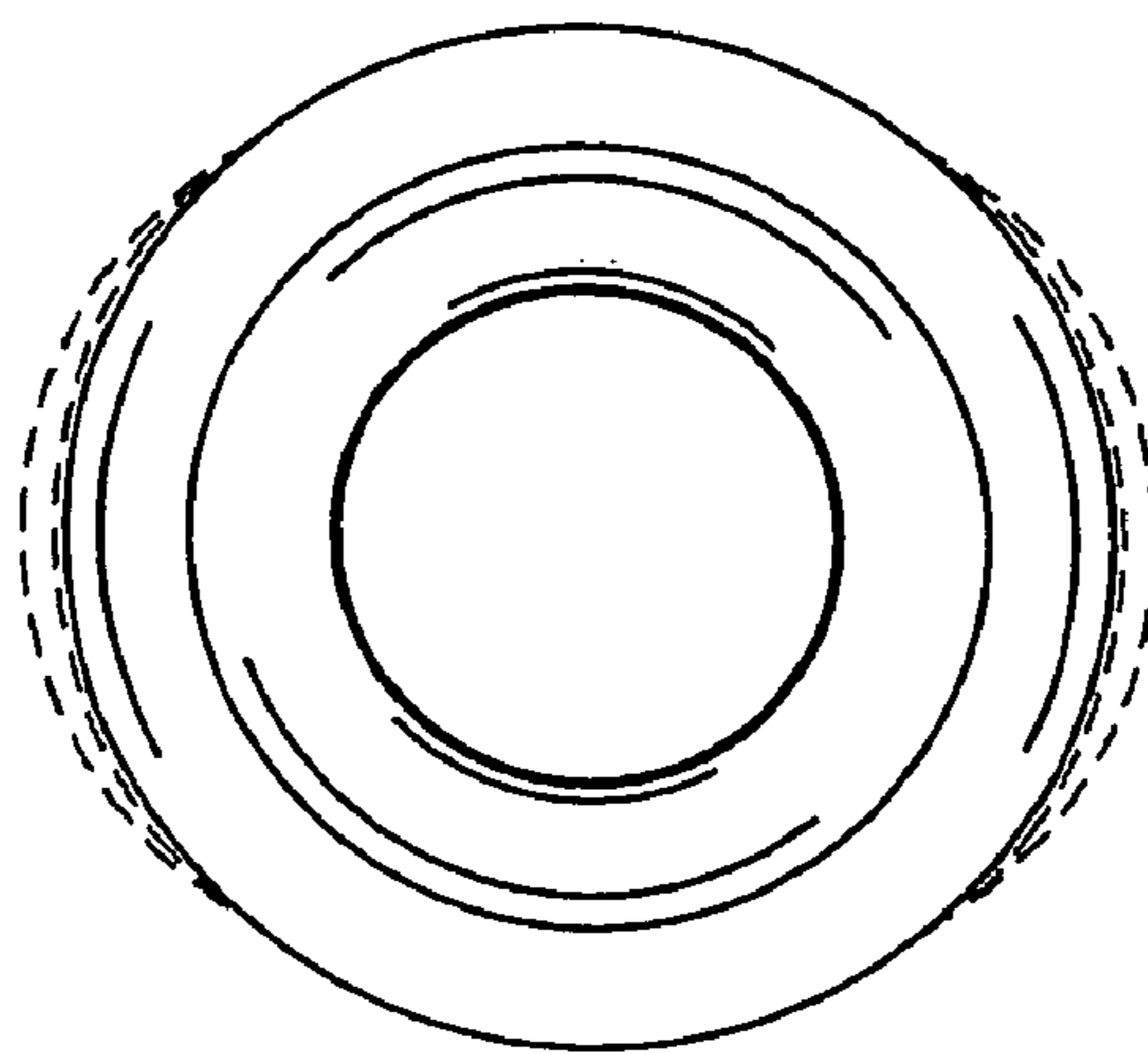

FIG. 14