



US00D586368S

(12) **United States Design Patent**
Bae

(10) **Patent No.:** **US D586,368 S**
(45) **Date of Patent:** **** Feb. 10, 2009**

(54) **ICEBOX**

(75) Inventor: **Yun Seong Bae**, Seoul (KR)

(73) Assignee: **TAPS International Co., Ltd.** (KR)

(**) Term: **14 Years**

(21) Appl. No.: **29/296,530**

(22) Filed: **Oct. 23, 2007**

(30) **Foreign Application Priority Data**

Aug. 9, 2007 (KR) 30-2007-0034261

(51) **LOC (9) Cl.** **15-07**

(52) **U.S. Cl.** **D15/89**

(58) **Field of Classification Search** D15/79,
D15/80, 82, 89, 90; D7/550.1, 601, 603,
D7/605, 609, 612; D9/414, 430, 432, 434,
D9/435, 454, 456, 734; 62/3.6, 3.61, 3.62,
62/3.63, 371, 440, 529, 531; 312/400-408;
229/100, 112, 113, 115, 116, 122, 125.19,
229/162.1, 922, 938; 206/524.6, 769; D23/364
See application file for complete search history.

(56) **References Cited**

U.S. PATENT DOCUMENTS

3,565,322 A * 2/1971 Cerf 206/524.6
D245,580 S * 8/1977 Larsson et al. D9/432
D251,546 S * 4/1979 Larsson et al. D9/432
D322,939 S * 1/1992 Murray D9/432
D449,525 S * 10/2001 Sturgess D9/432

D458,841 S * 6/2002 Goguen et al. D9/432
D468,328 S * 1/2003 Humber et al. D15/89
D479,465 S * 9/2003 Knasel D9/432
D496,275 S * 9/2004 Hamuro et al. D9/432
D526,194 S * 8/2006 Hamuro et al. D9/432
D529,795 S * 10/2006 Kragtwijk D9/418
D551,968 S * 10/2007 Kleinsmith D9/432
D575,382 S * 8/2008 Hammes D23/364

* cited by examiner

Primary Examiner—Stella M Reid

Assistant Examiner—Shanda C Hill

(74) *Attorney, Agent, or Firm*—Cantor Colburn LLP

(57) **CLAIM**

The ornamental design for an icebox, as shown and described.

DESCRIPTION

FIG. 1 is a perspective view of an icebox, showing my new design;

FIG. 2 is a front elevational view thereof;

FIG. 3 is a rear elevational view thereof;

FIG. 4 is a left side elevational view thereof;

FIG. 5 is a right side elevational view thereof;

FIG. 6 is a top plan view thereof;

FIG. 7 is a bottom plan view thereof; and,

FIG. 8 is an enlarged cross-sectional view taken along line 8—8 of FIG. 6.

1 Claim, 5 Drawing Sheets

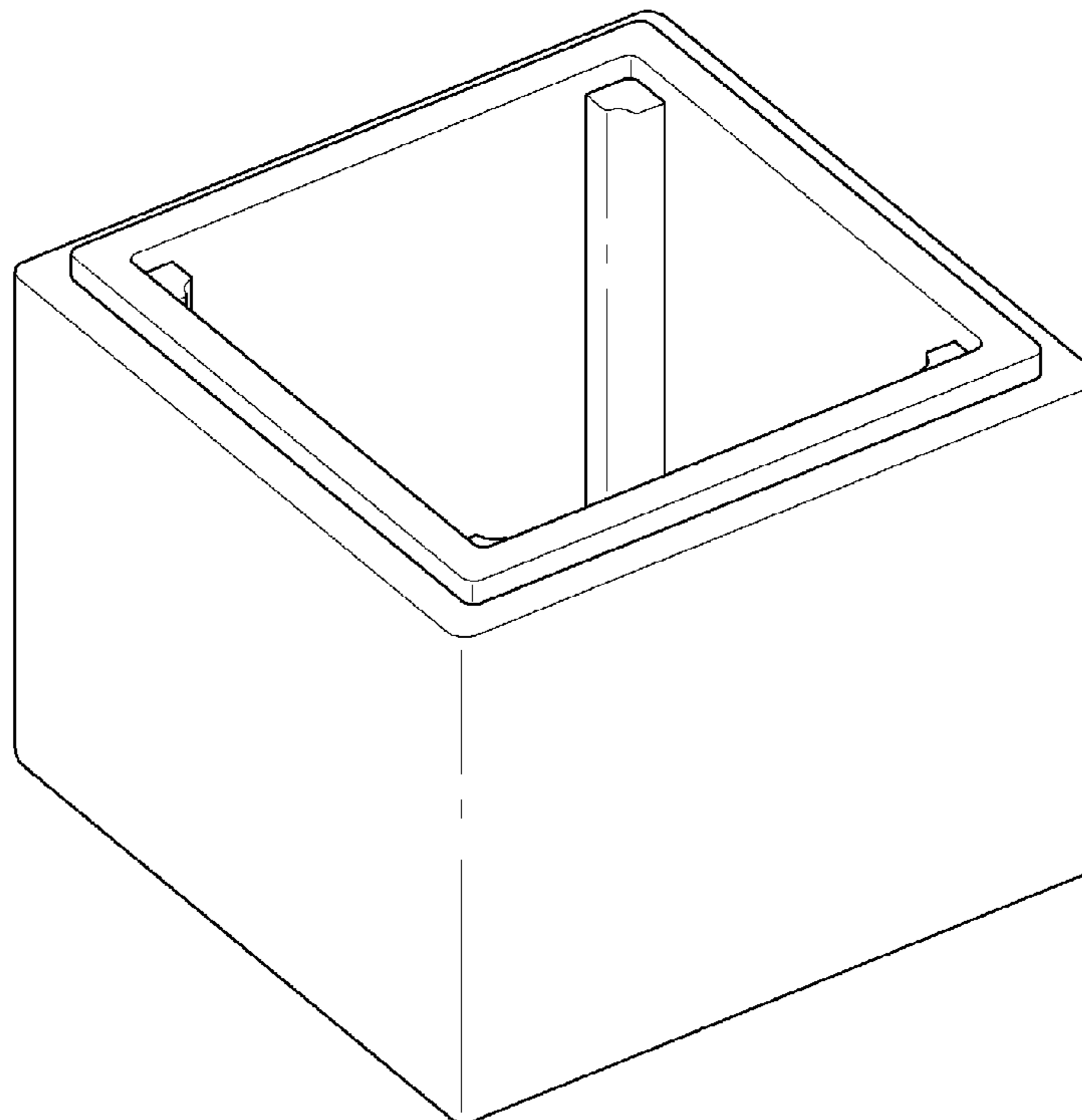

FIG. 1

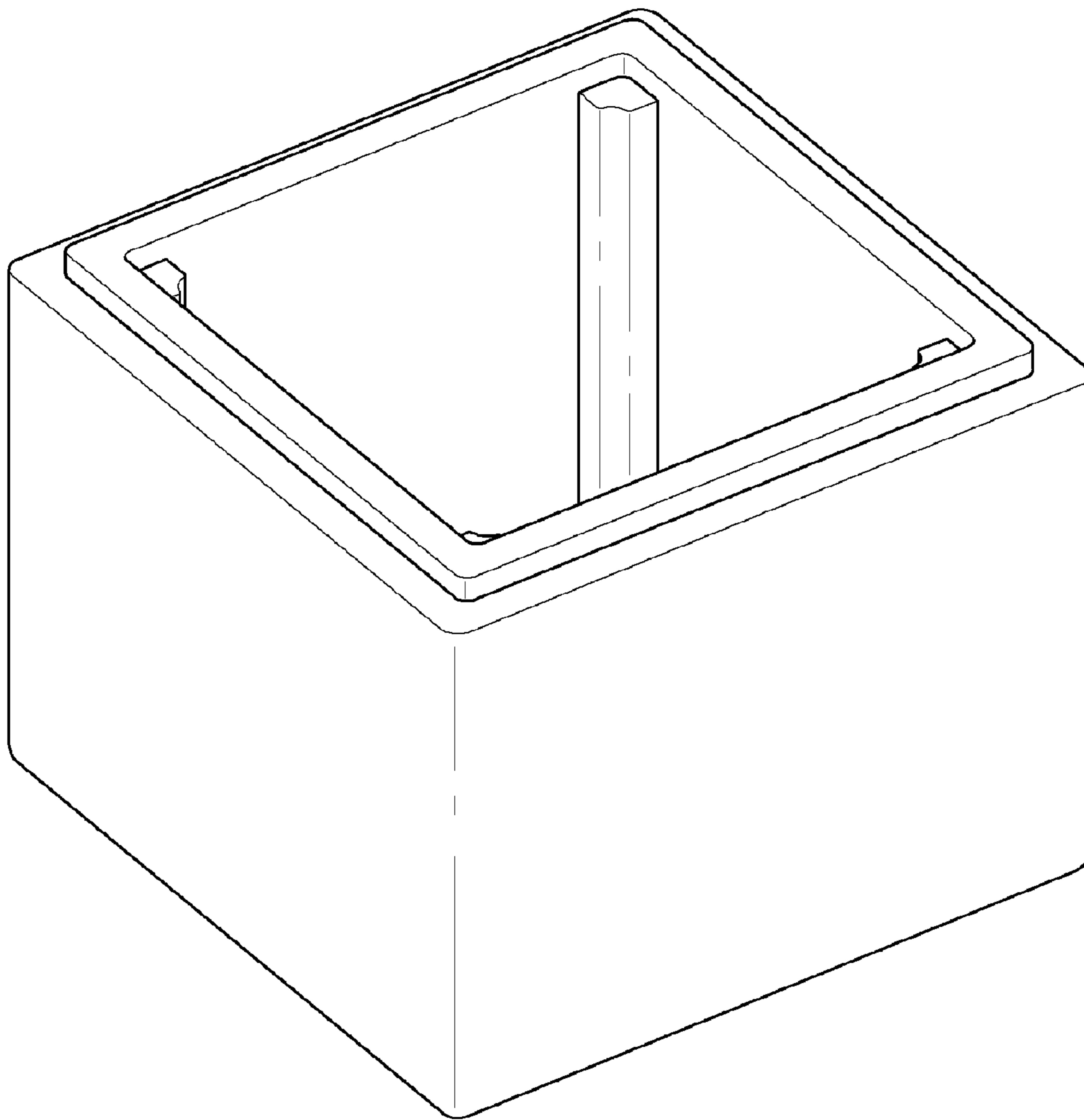

FIG. 2

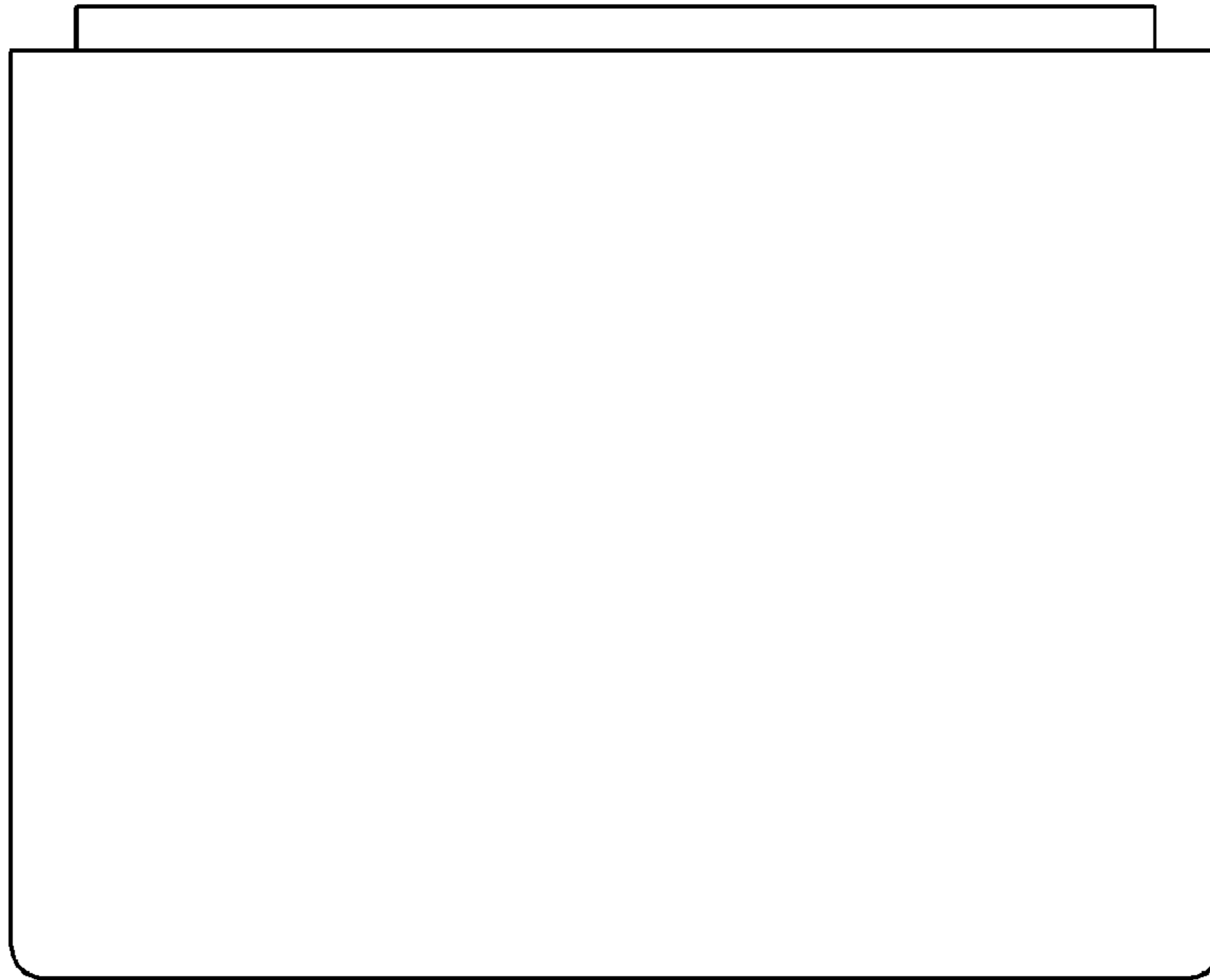

FIG. 3



FIG. 4

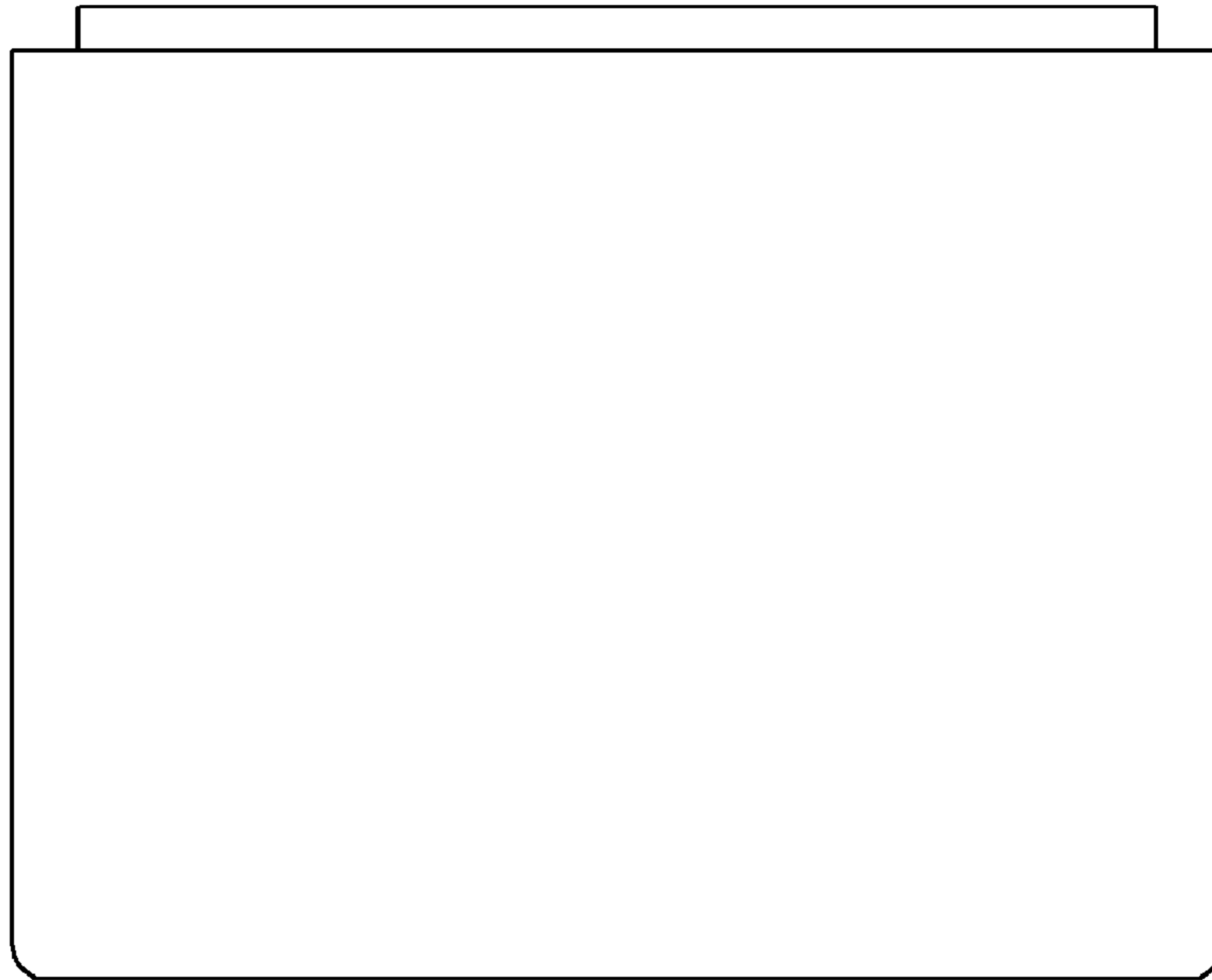

FIG. 5

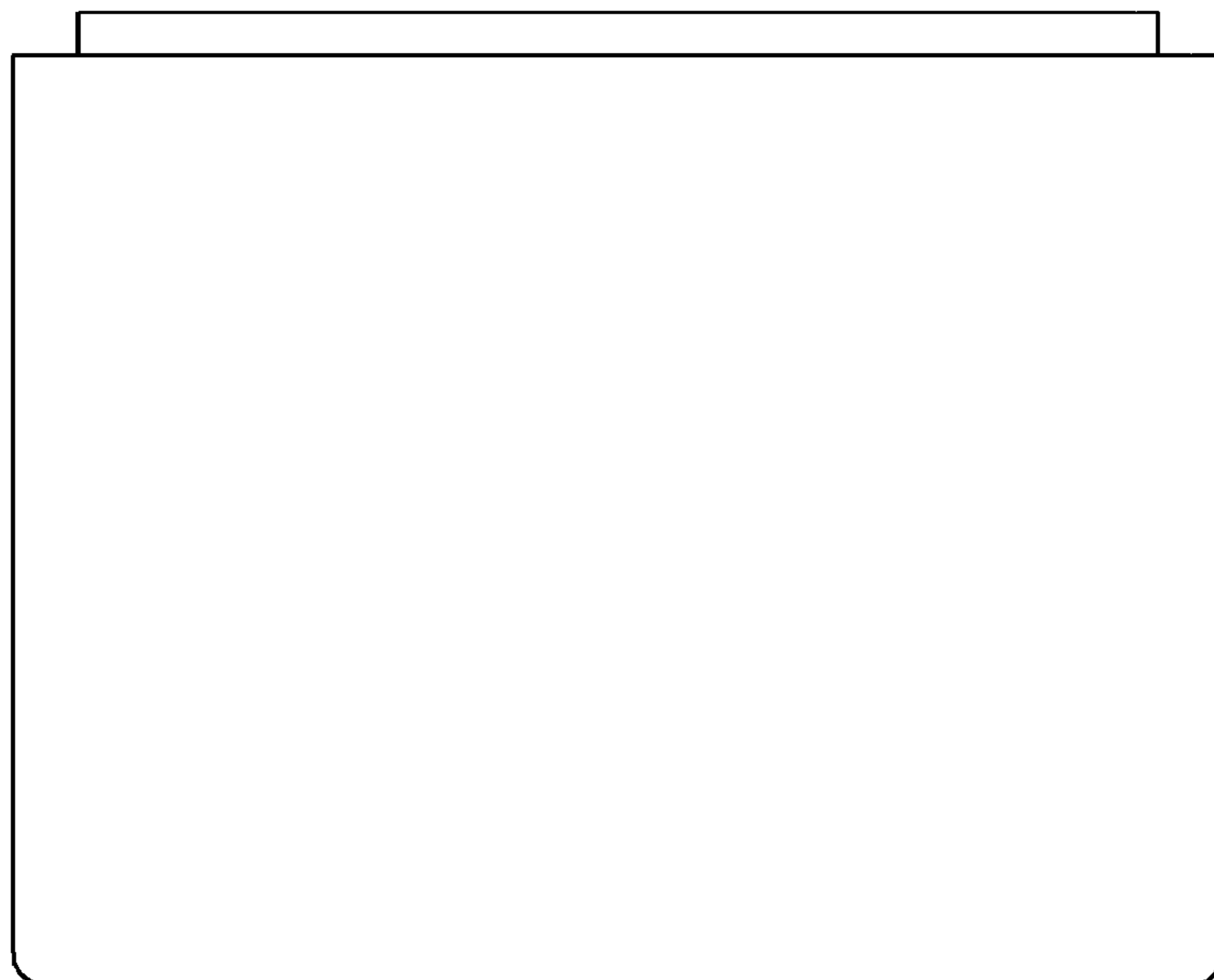

FIG. 6

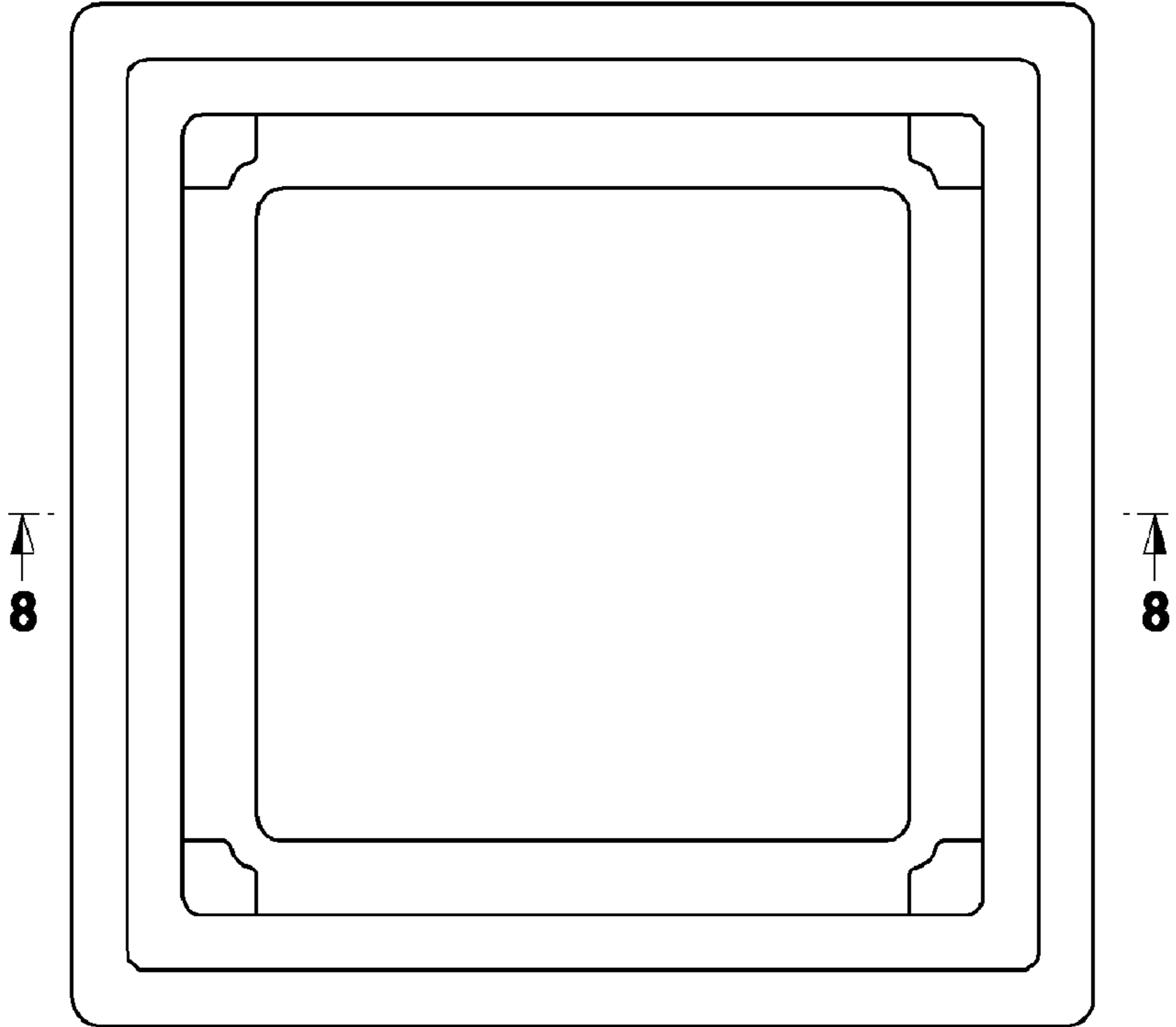

FIG. 7

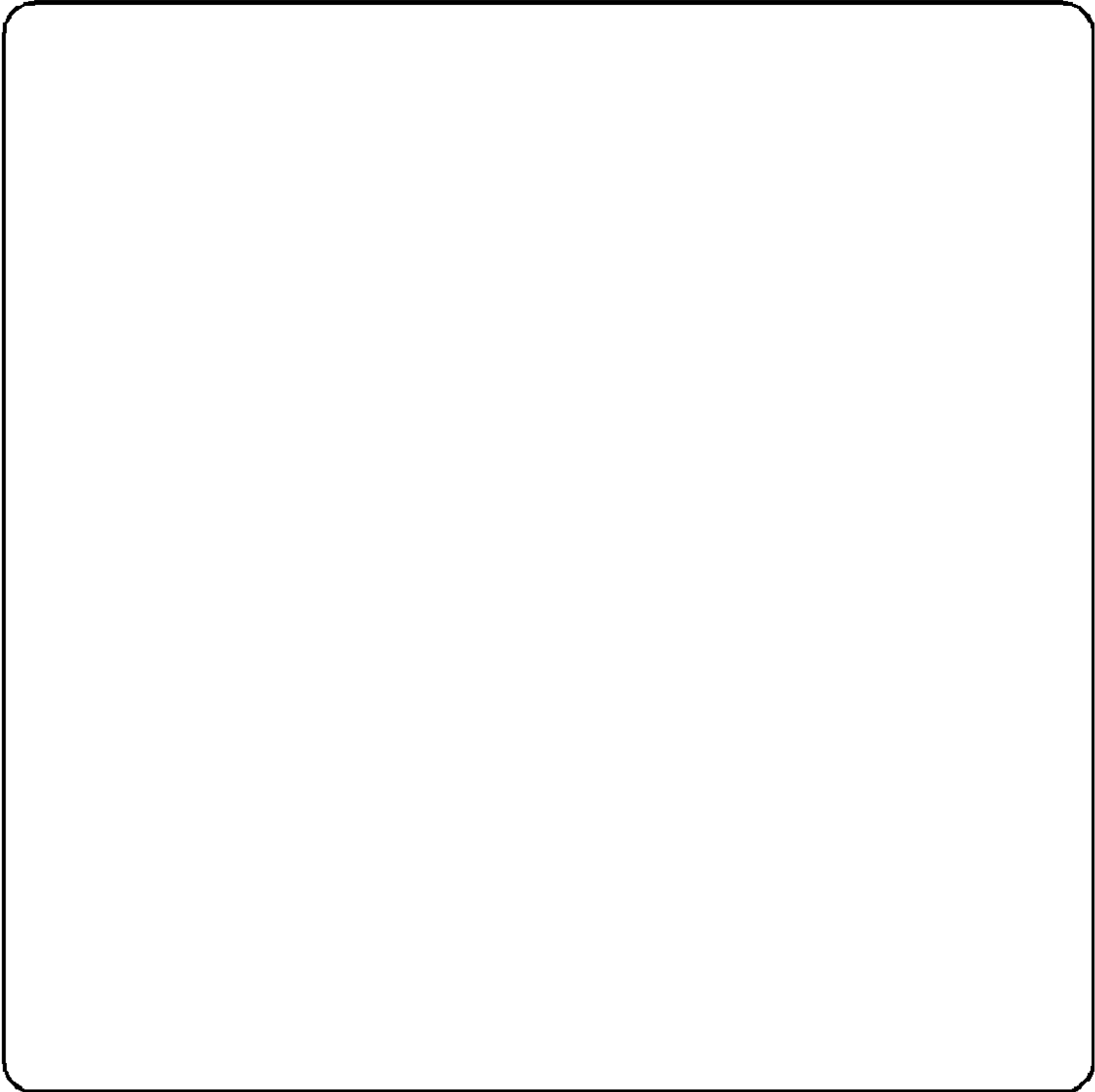

FIG. 8

