



US00D586365S

(12) **United States Design Patent**
Shimokawa

(10) **Patent No.:** **US D586,365 S**

(45) **Date of Patent:** **** Feb. 10, 2009**

(54) **ROTOR FOR AN INTERNAL COMBUSTION ENGINE**

(75) Inventor: **Kouichi Shimokawa**, Kawagoe (JP)

(73) Assignee: **Husqvarna Zenoah Co., Ltd.**,
Kawagoe-shi (JP)

(**) Term: **14 Years**

(21) Appl. No.: **29/299,451**

(22) Filed: **Dec. 27, 2007**

(30) **Foreign Application Priority Data**

Jun. 29, 2007 (JP) 2007-017456

(51) **LOC (9) Cl.** **15-01**

(52) **U.S. Cl.** **D15/5**

(58) **Field of Classification Search** D15/1,
D15/3, 5; 55/337; 123/41.67, 198 E; 418/91
See application file for complete search history.

(56) **References Cited**

U.S. PATENT DOCUMENTS

3,652,190 A * 3/1972 Keller et al. 418/54
3,743,449 A * 7/1973 Steinwart 418/39

* cited by examiner

Primary Examiner—Lisa P Lichtenstein

(74) *Attorney, Agent, or Firm*—Fox Rothschild, LLP

(57) **CLAIM**

The ornamental design for a rotor for an internal combustion engine, as shown and described.

DESCRIPTION

FIG. 1 is a front perspective view of a rotor for an internal combustion engine showing my new design;

FIG. 2 is a rear perspective view thereof;

FIG. 3 is a front view thereof;

FIG. 4 is a rear view thereof;

FIG. 5 is a top plan view thereof;

FIG. 6 is a bottom plan view thereof;

FIG. 7 is a right side view thereof; and,

FIG. 8 is a left side view thereof.

The rotor is attached to a shaft of the internal combustion engine. It is used to control ignition and cool the engine.

1 Claim, 6 Drawing Sheets

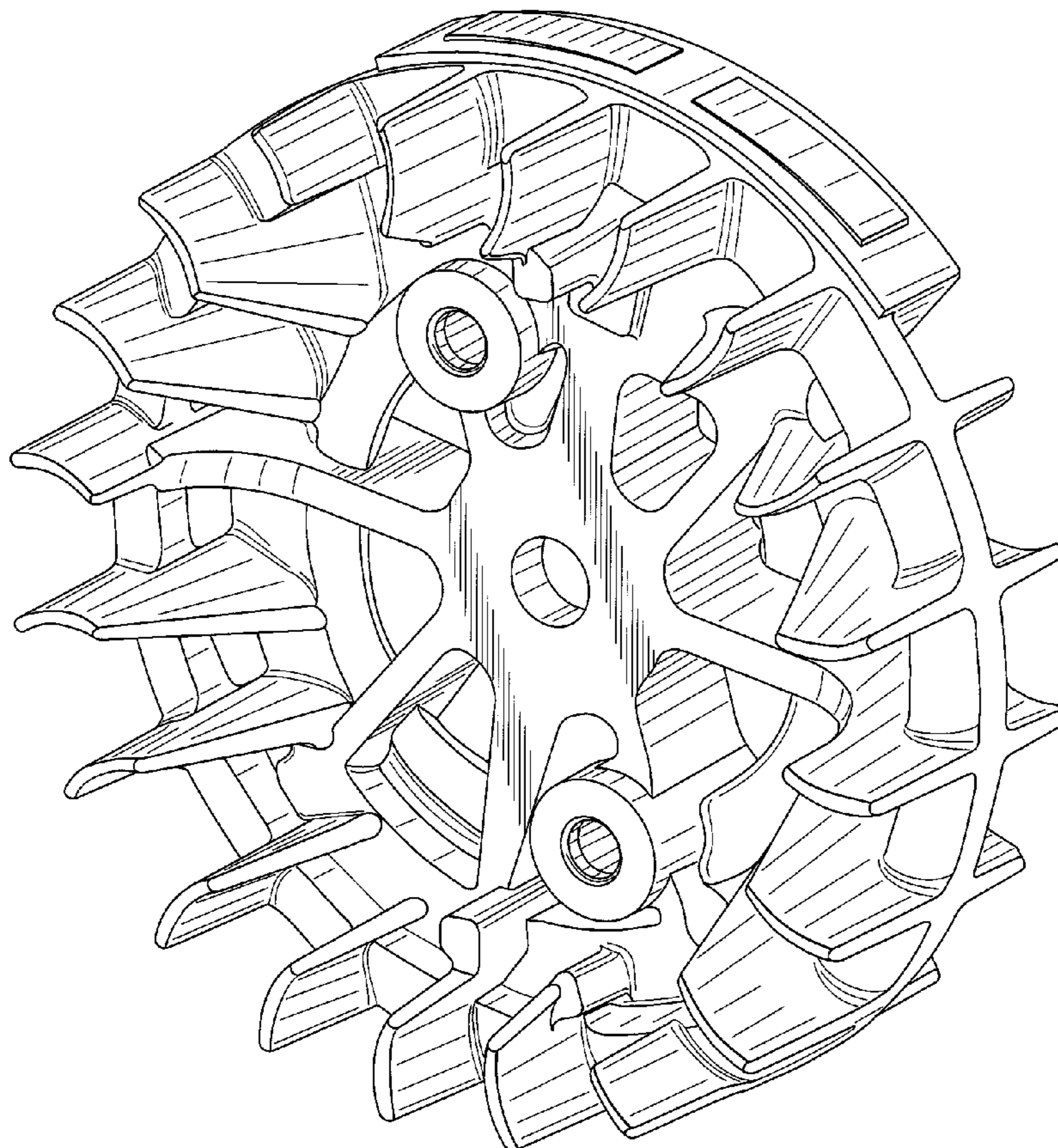

FIG. 1

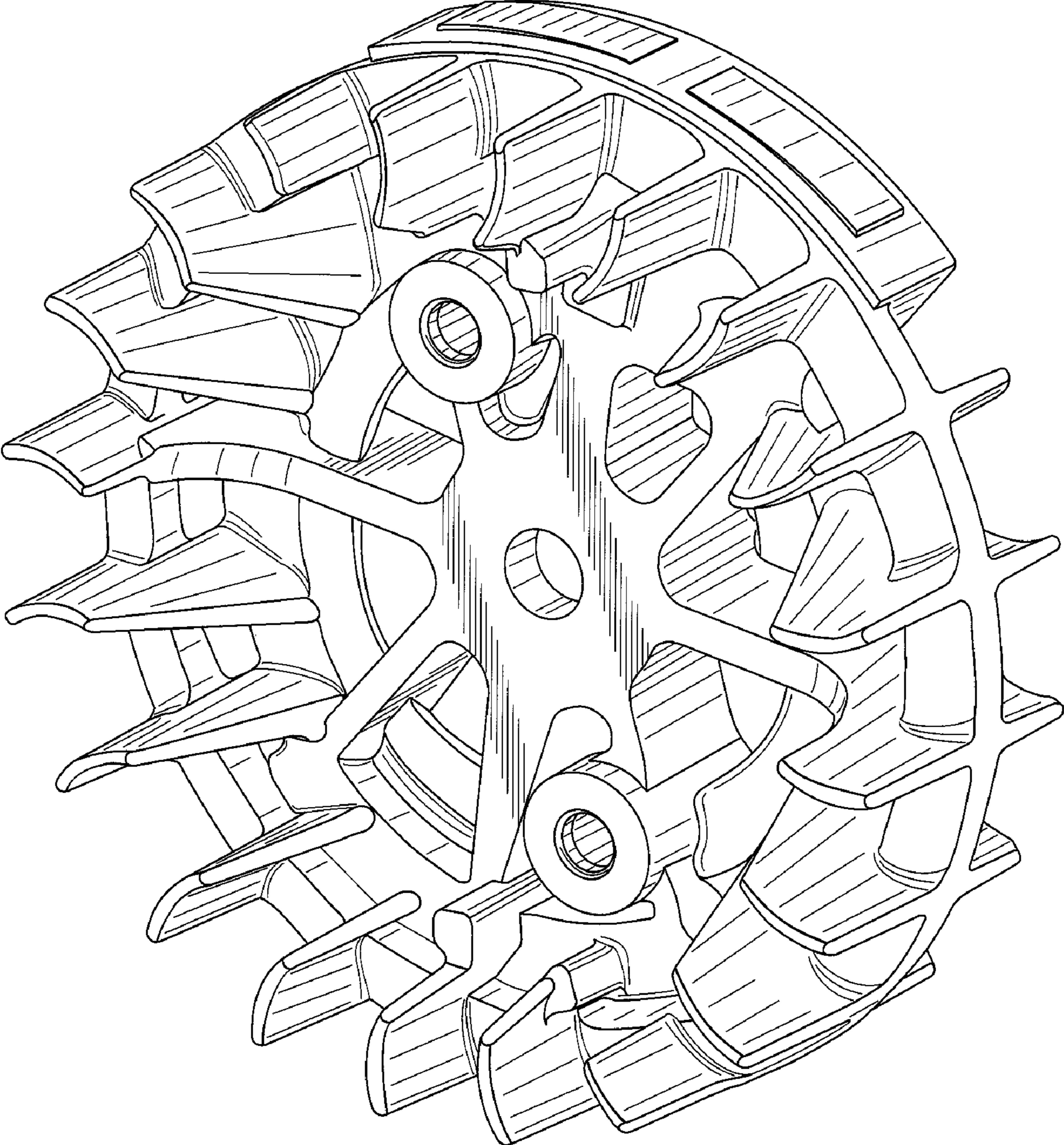

FIG. 2

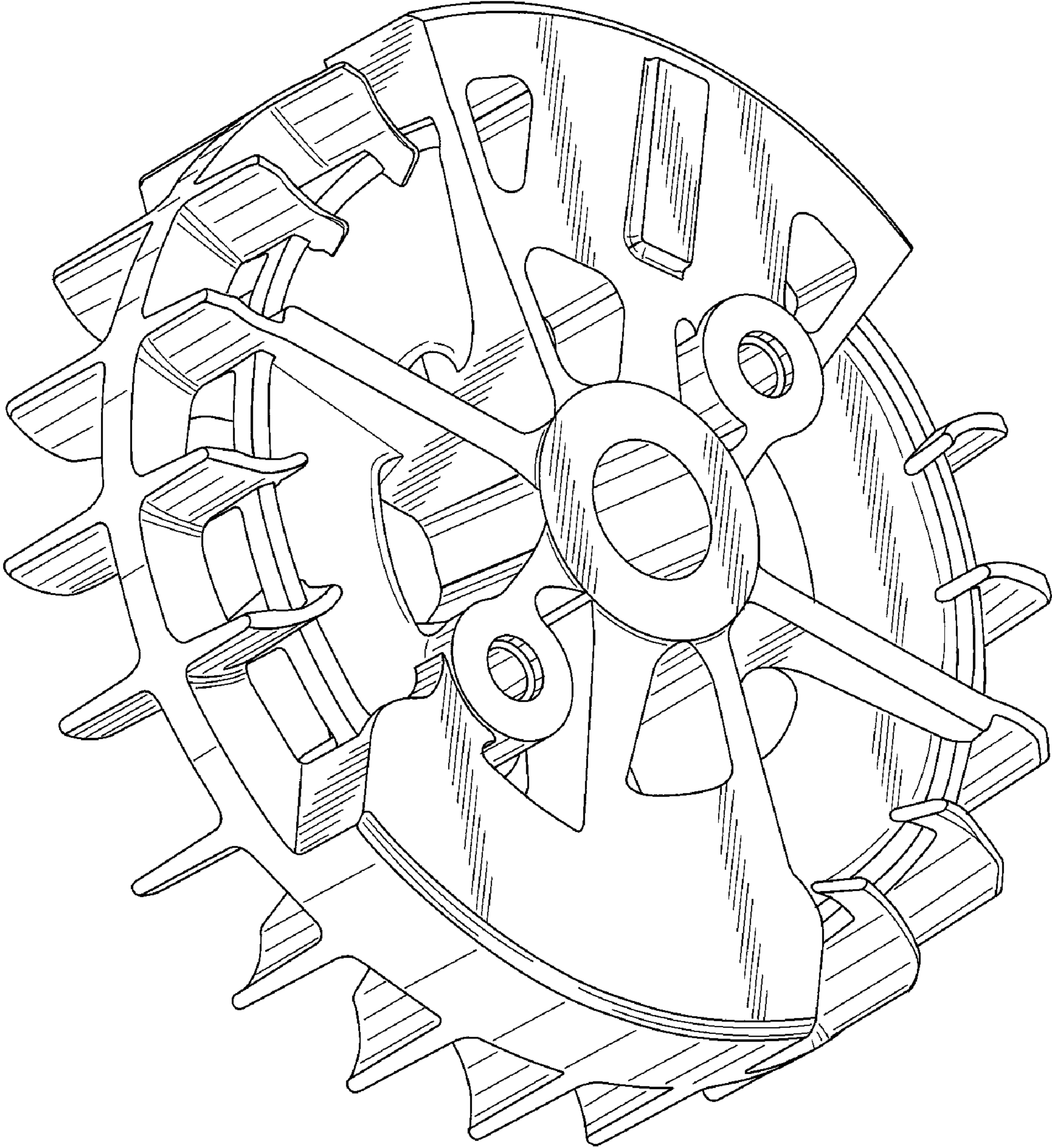

FIG. 3

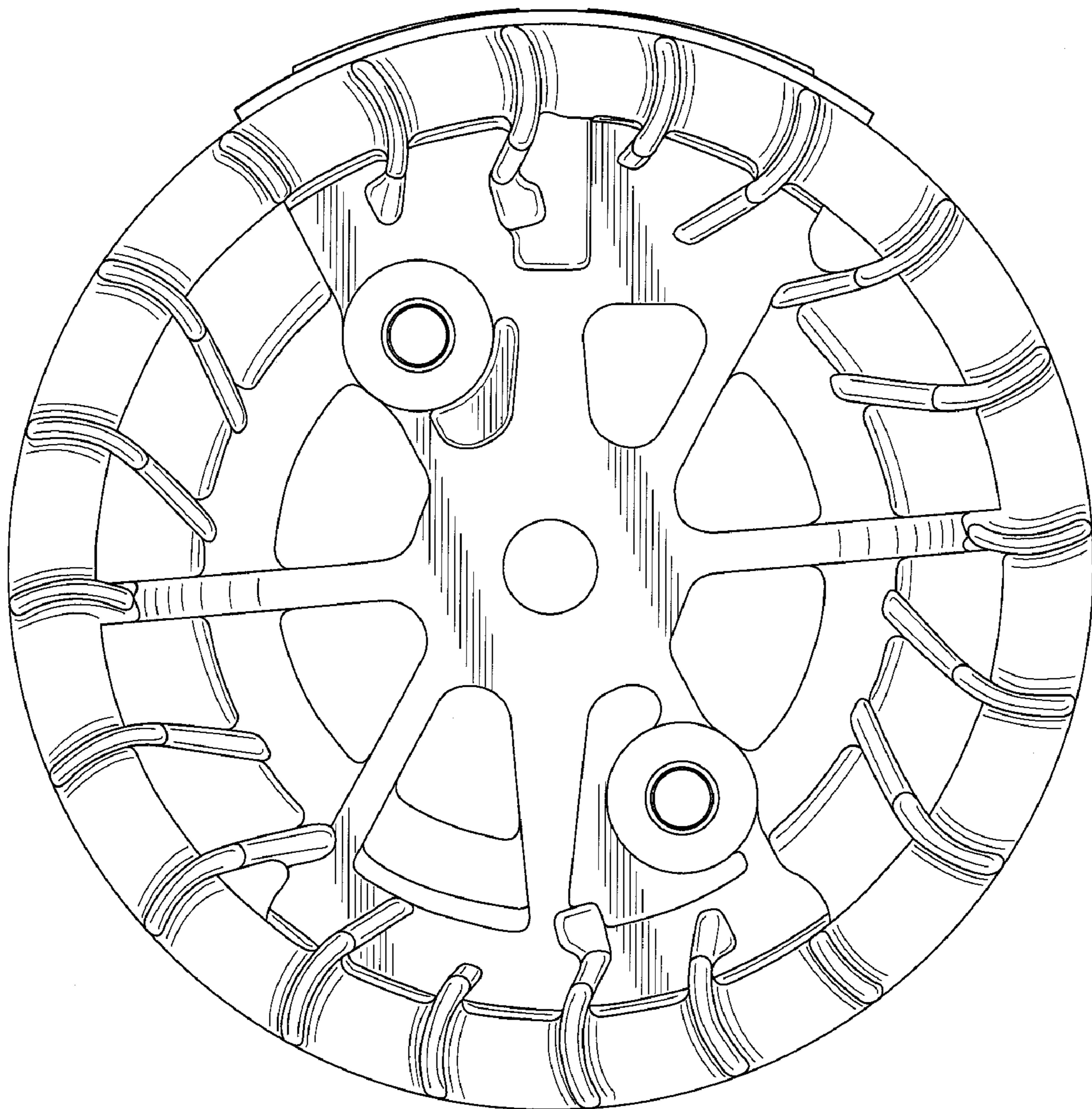

FIG. 4

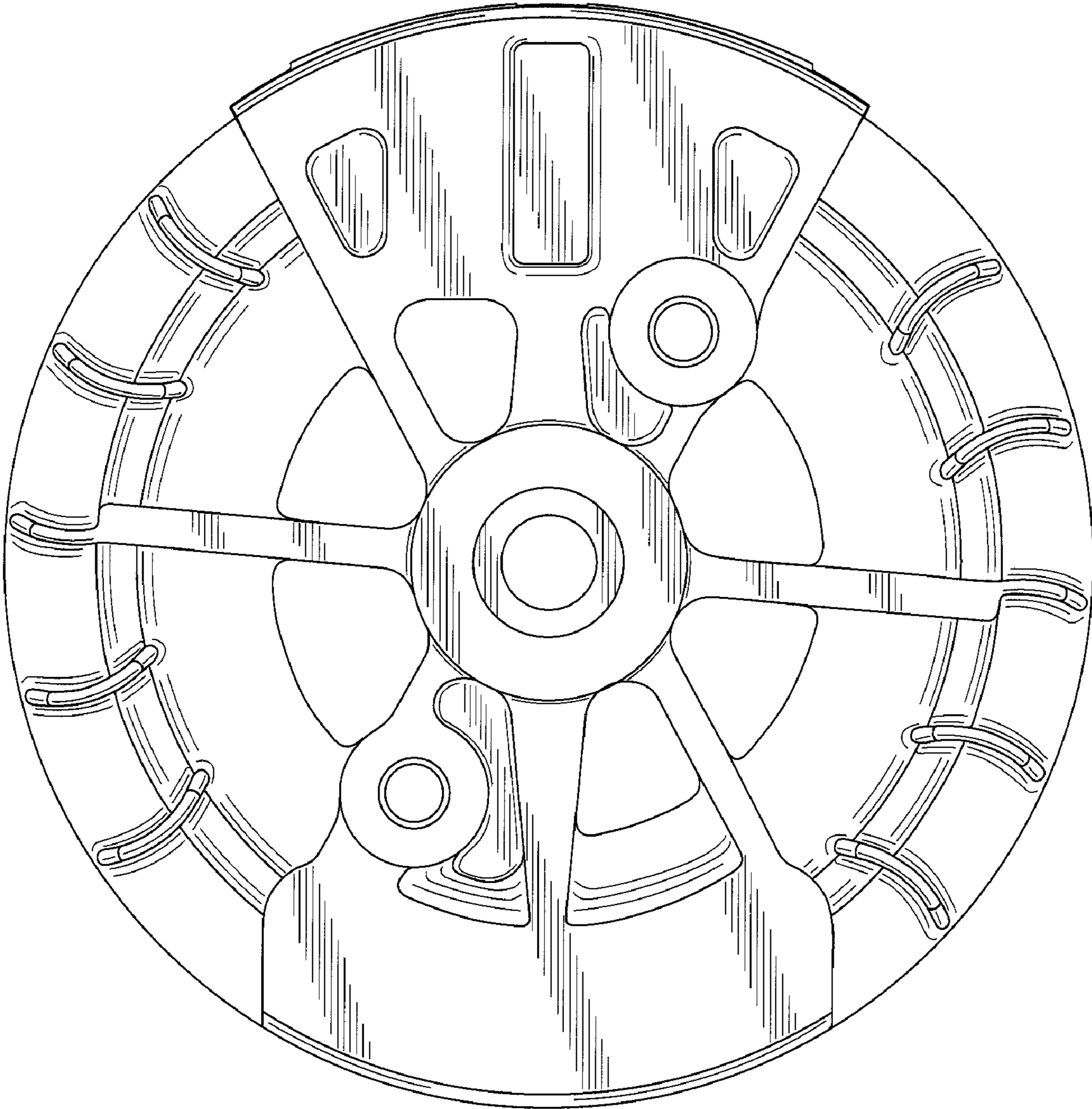

FIG. 5

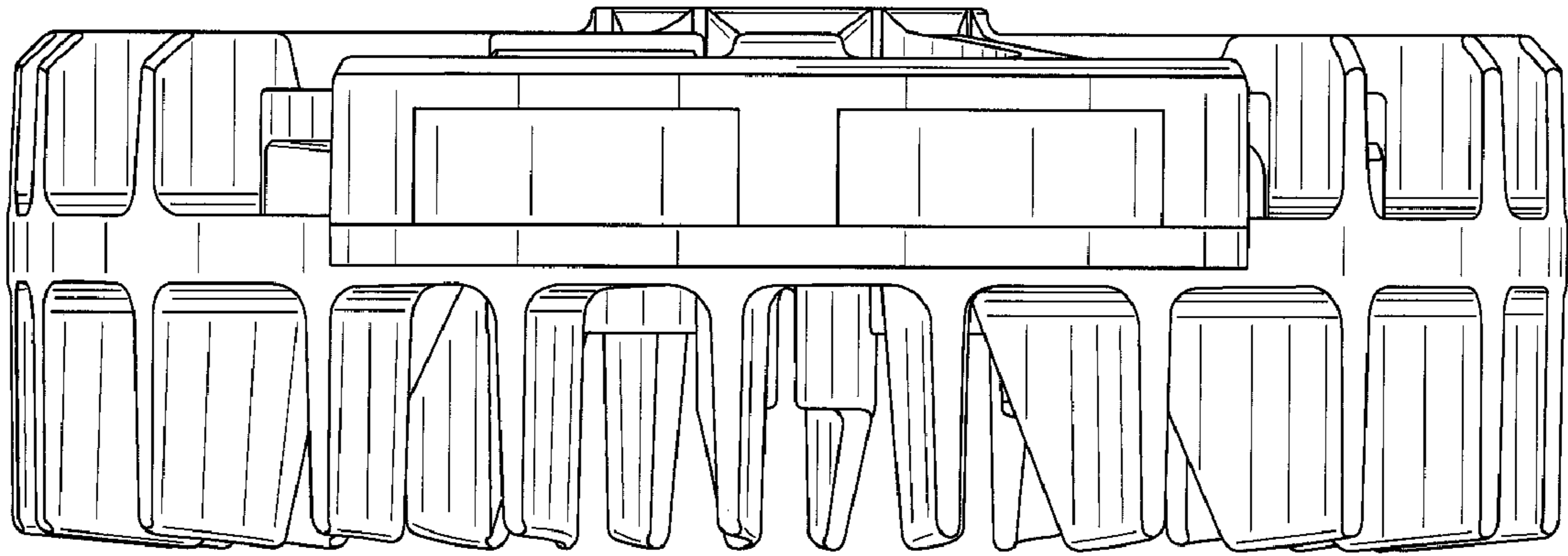

FIG. 6

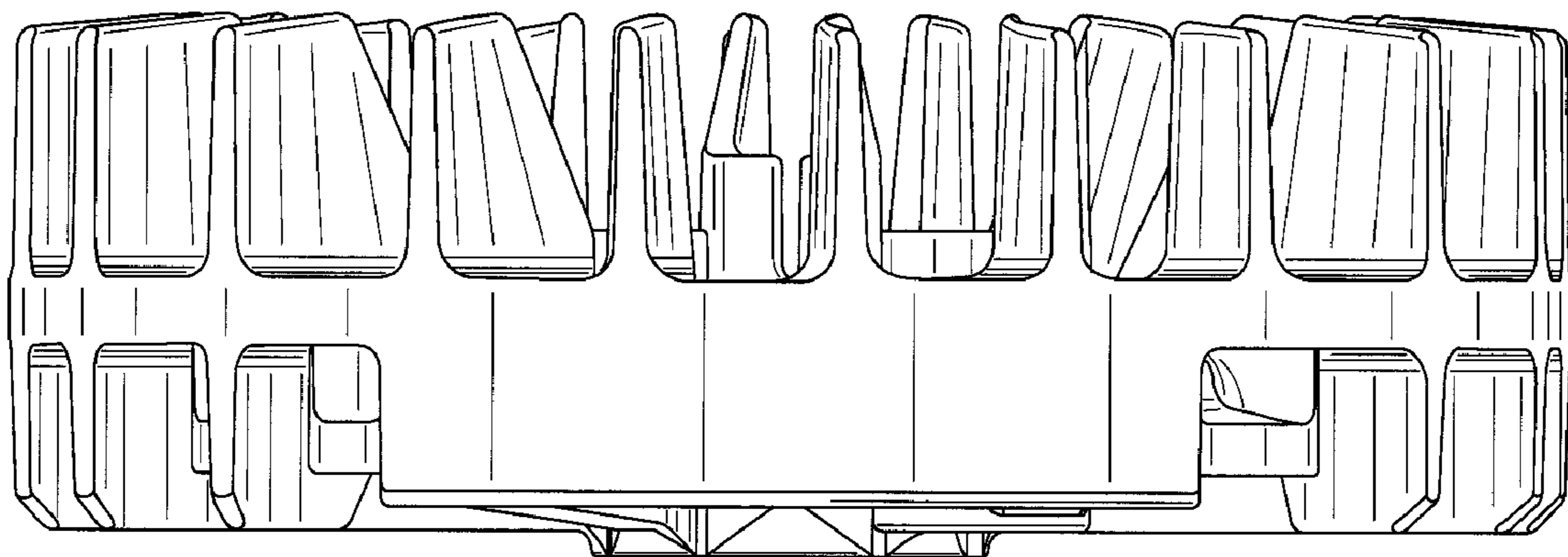

FIG. 7

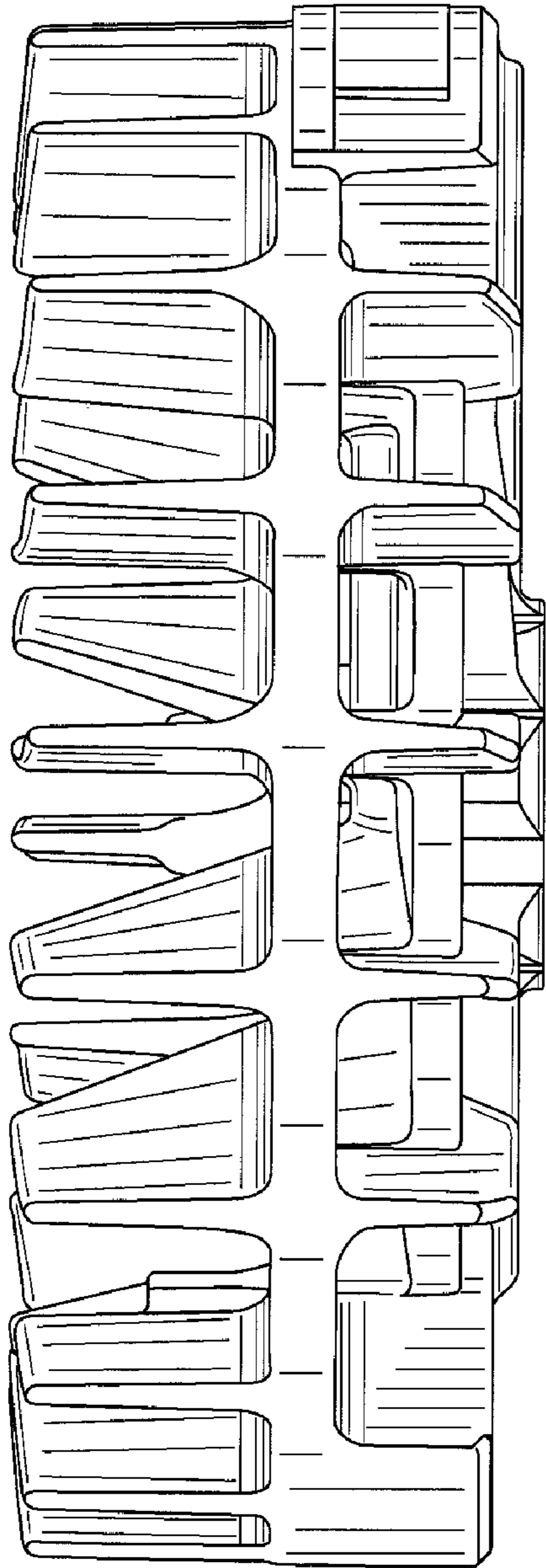

FIG. 8

