



US00D586276S

(12) **United States Design Patent**
Pfeiffer

(10) **Patent No.:** **US D586,276 S**

(45) **Date of Patent:** **** Feb. 10, 2009**

(54) **SIDE MIRROR FOR A VEHICLE**

(75) Inventor: **Peter Pfeiffer**, Boeblingen (DE)

(73) Assignee: **Daimler AG**, Stuttgart (DE)

(**) Term: **14 Years**

(21) Appl. No.: **29/271,154**

(22) Filed: **Jan. 11, 2007**

(30) **Foreign Application Priority Data**

Jul. 12, 2006 (DE) 40603535

(51) **LOC (9) Cl.** **12-16**

(52) **U.S. Cl.** **D12/187**

(58) **Field of Classification Search** D12/187-189;
359/838-851, 855-868, 871-881; 248/475.1,
248/476, 480, 481, 485-487

See application file for complete search history.

(56) **References Cited**

U.S. PATENT DOCUMENTS

D549,625 S *	8/2007	Pfeiffer	D12/187
D551,606 S *	9/2007	Pfeiffer	D12/187
D554,032 S *	10/2007	Bengtsson	D12/187
D571,698 S *	6/2008	Imai et al.	D12/187
D577,639 S *	9/2008	Choi et al.	D12/187

* cited by examiner

Primary Examiner—Melody N Brown

(74) *Attorney, Agent, or Firm*—Crowell & Moring LLP

(57) **CLAIM**

The ornamental design for a side mirror for a vehicle, as shown and described.

DESCRIPTION

This application is related to the following co-pending application, of the inventor:

Application Ser. No. 29/262,750, entitled “Surface Configuration of a Vehicle, Toy, and/or Other Replicas”.

FIG. 1 is a rear perspective view a first embodiment of a side mirror for a vehicle according to my novel design;

FIG. 2 is a front perspective view thereof;

FIG. 3 is a side view thereof;

FIG. 4 is a rear view thereof;

FIG. 5 is a front view thereof;

FIG. 6 is a top view thereof; and

FIG. 7 is a bottom view thereof.

FIG. 8 is a rear perspective view a second embodiment of the side mirror for a vehicle according to my novel design;

FIG. 9 is a front perspective view of FIG. 8;

FIG. 10 is a side view of FIG. 8;

FIG. 11 is a rear view of FIG. 8;

FIG. 12 is a front view of FIG. 8;

FIG. 13 is a top view of FIG. 8; and,

FIG. 14 is a bottom view of FIG. 8.

The broken lines are for illustrative purposes only and form no part of the claimed design.

1 Claim, 12 Drawing Sheets

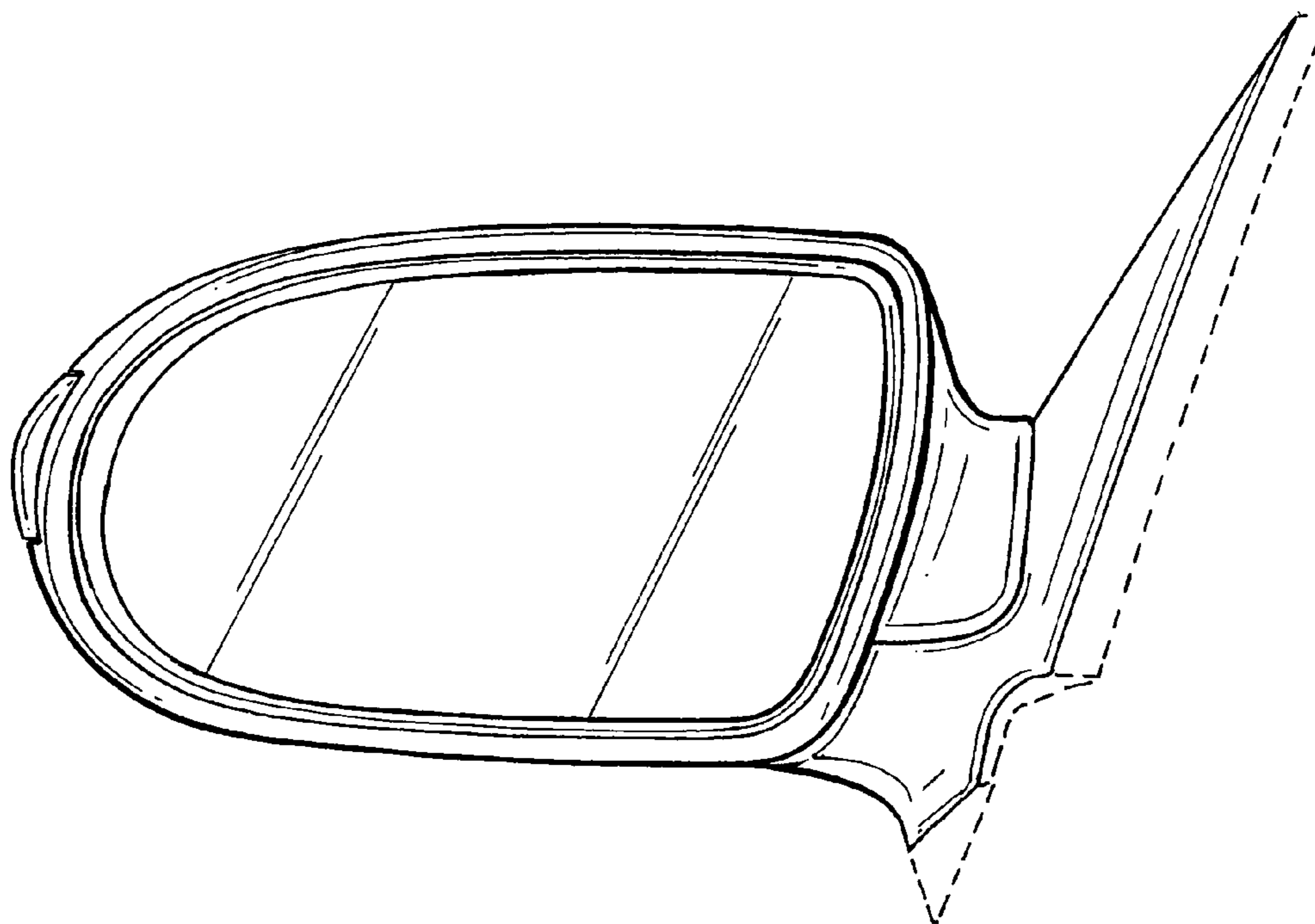

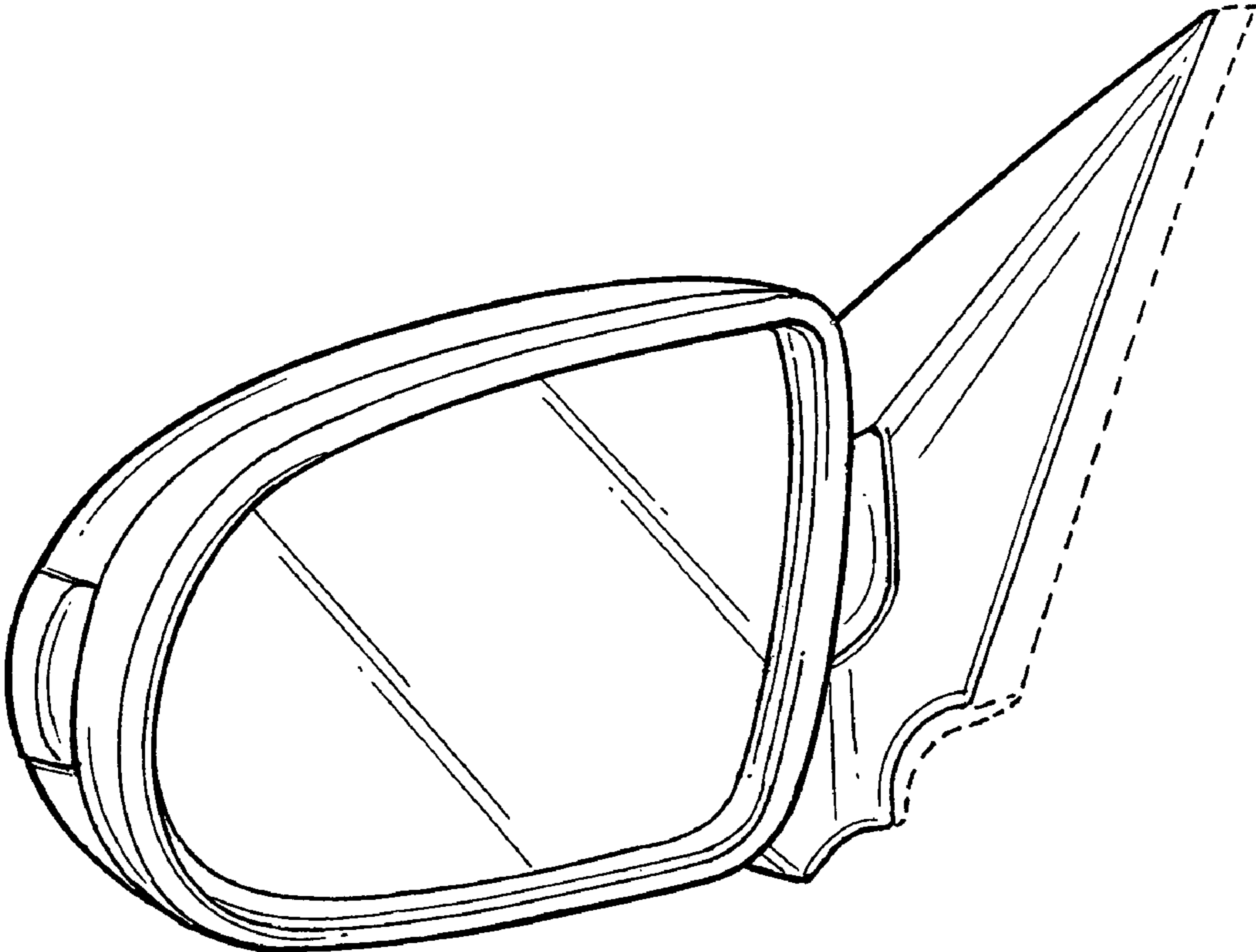

FIG. 1

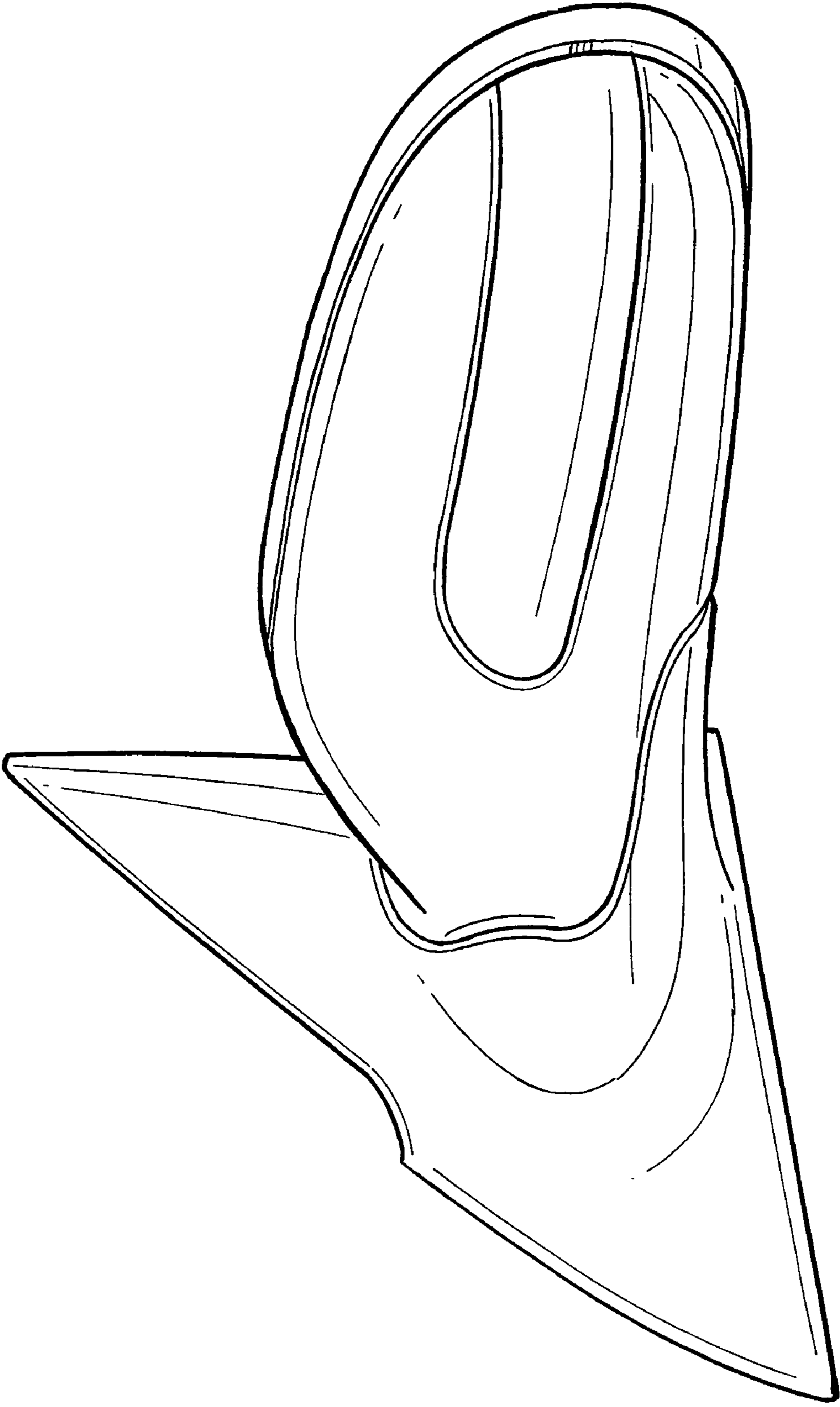

FIG. 2

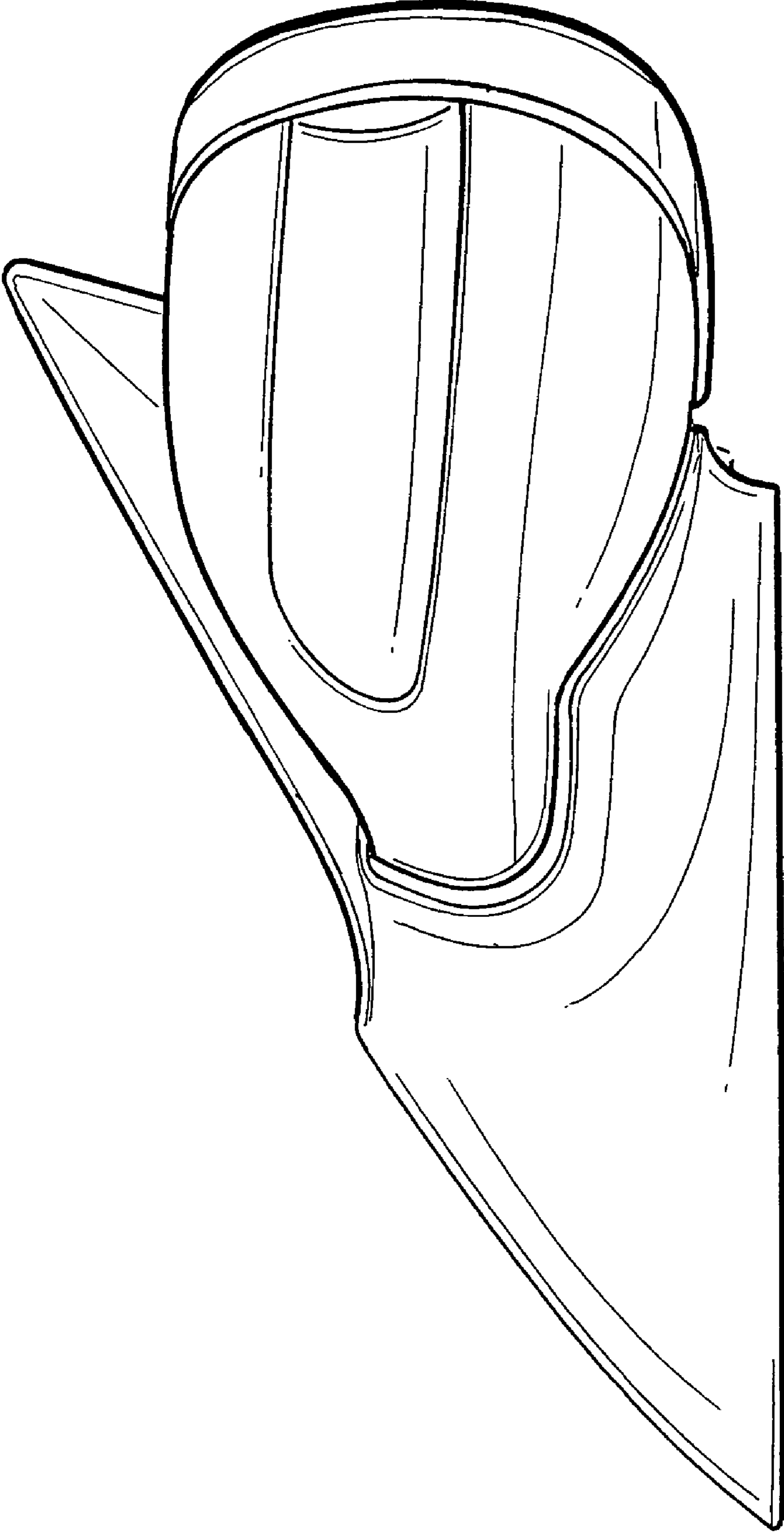

FIG. 3

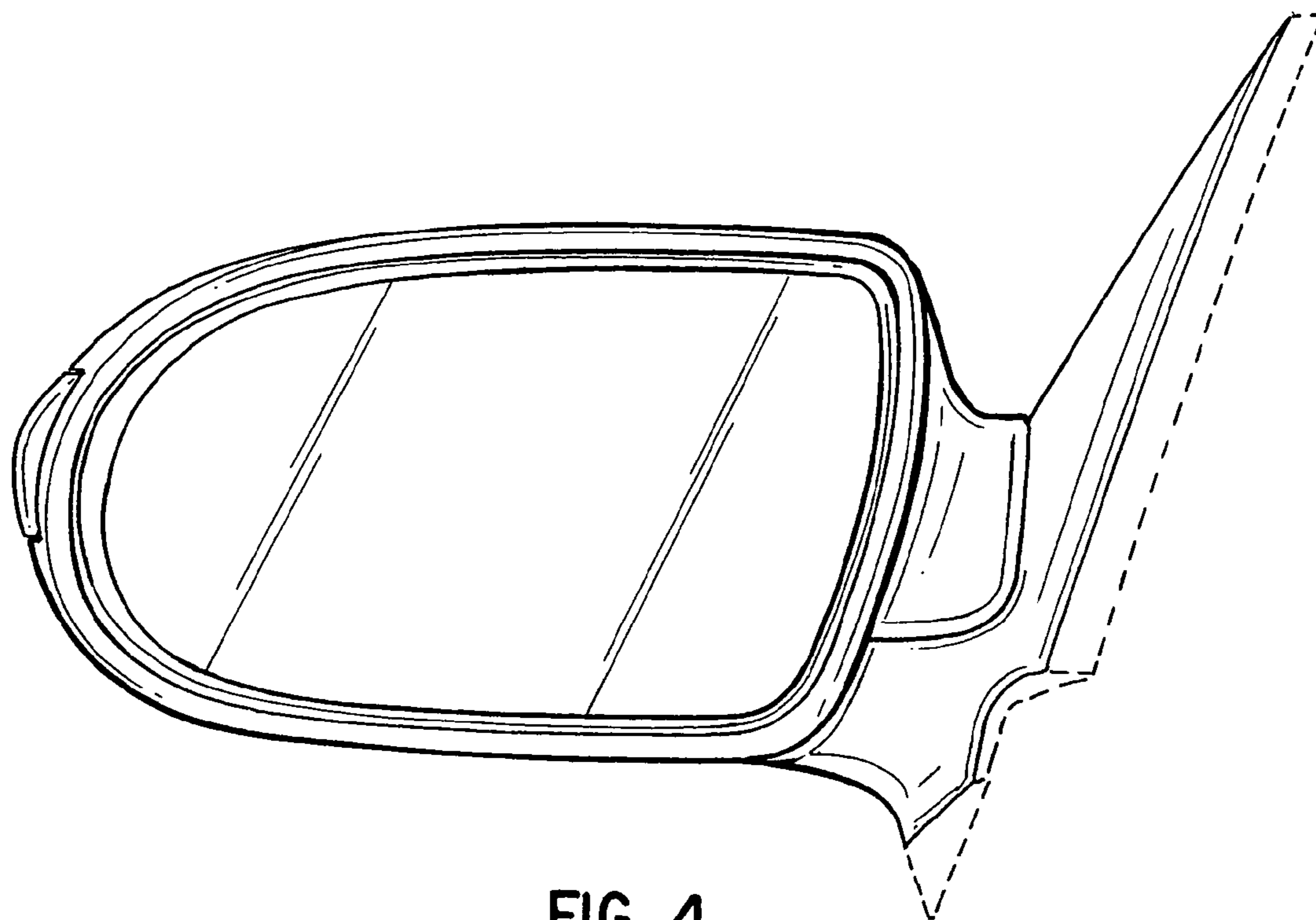

FIG. 4

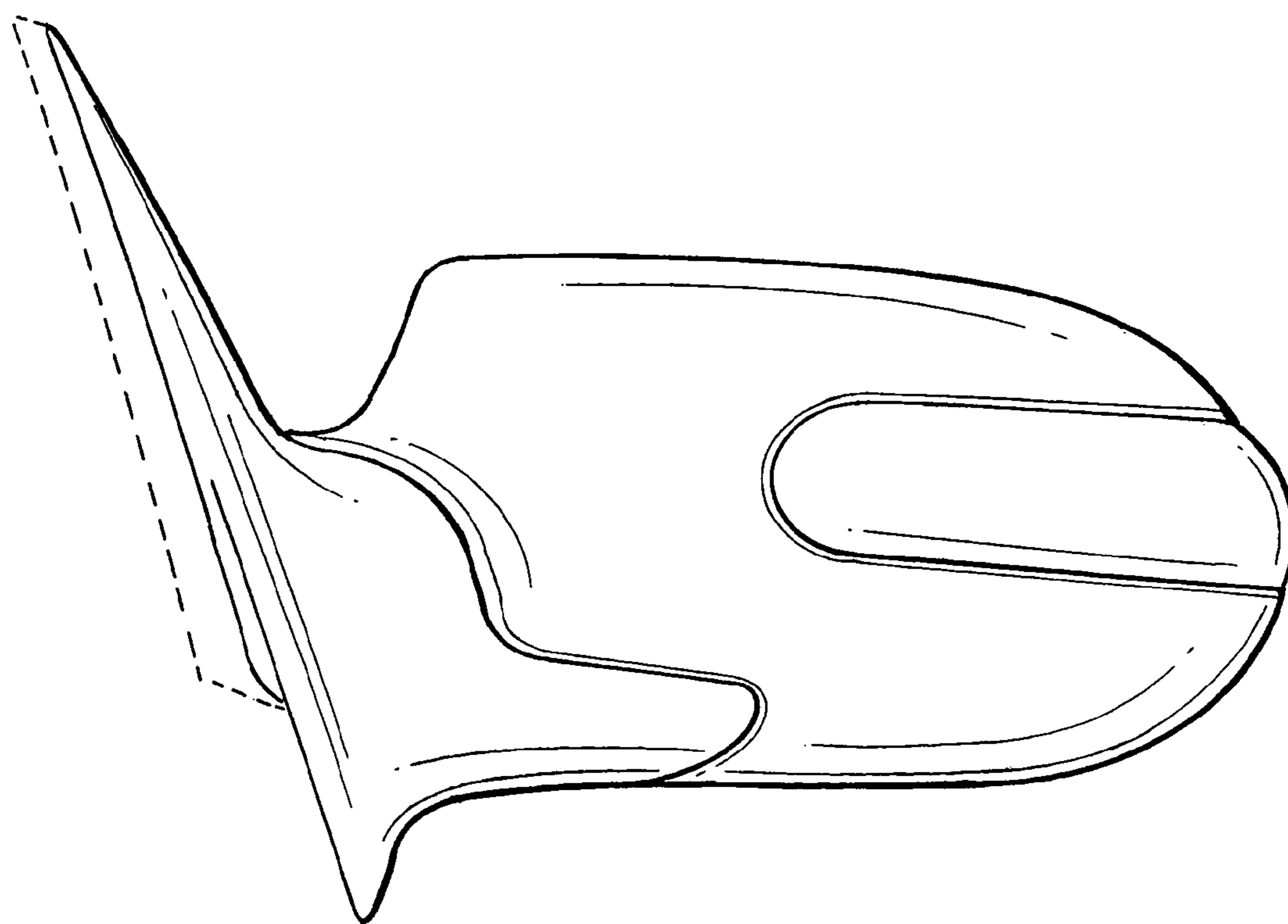

FIG. 5

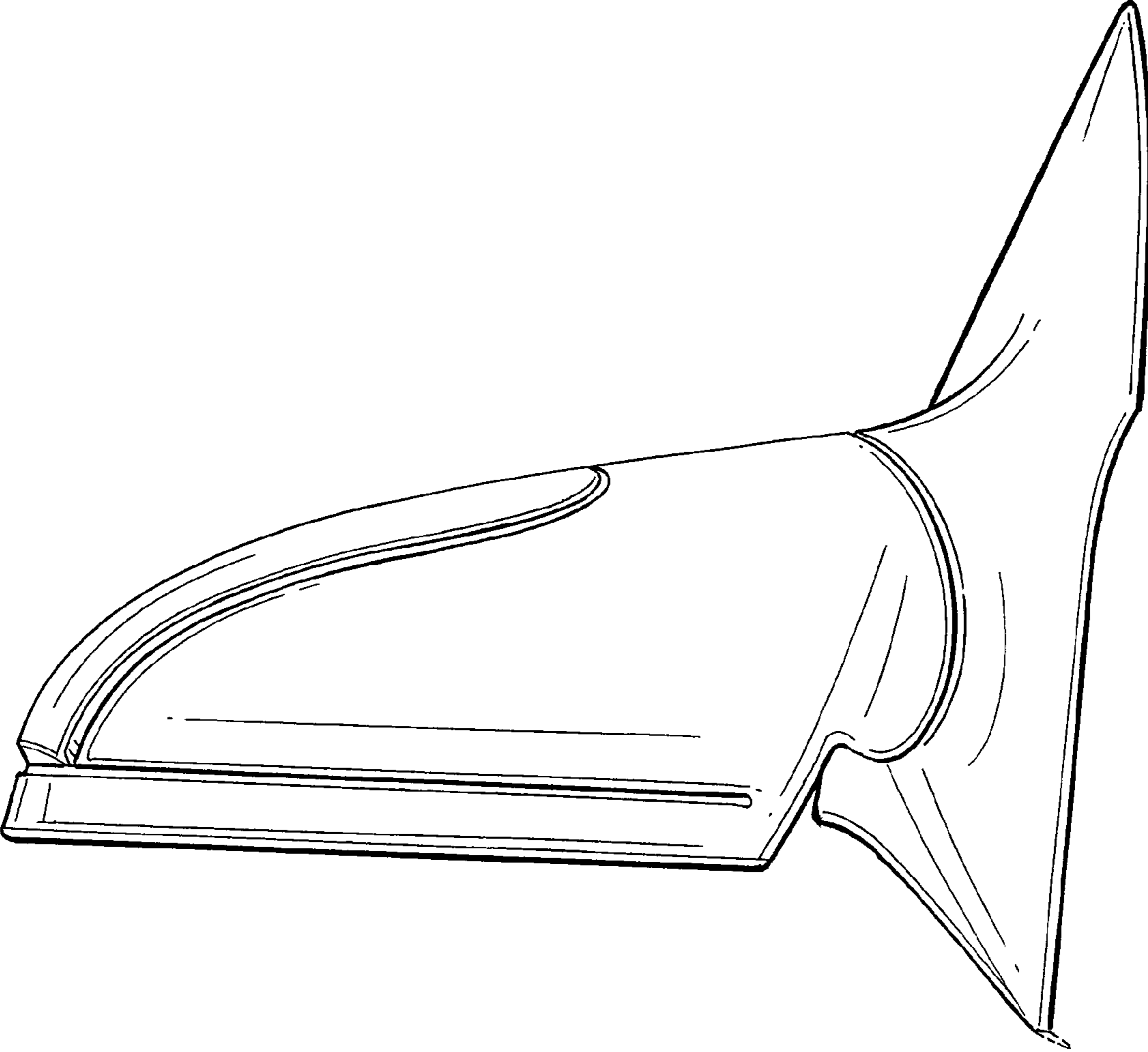

FIG. 6

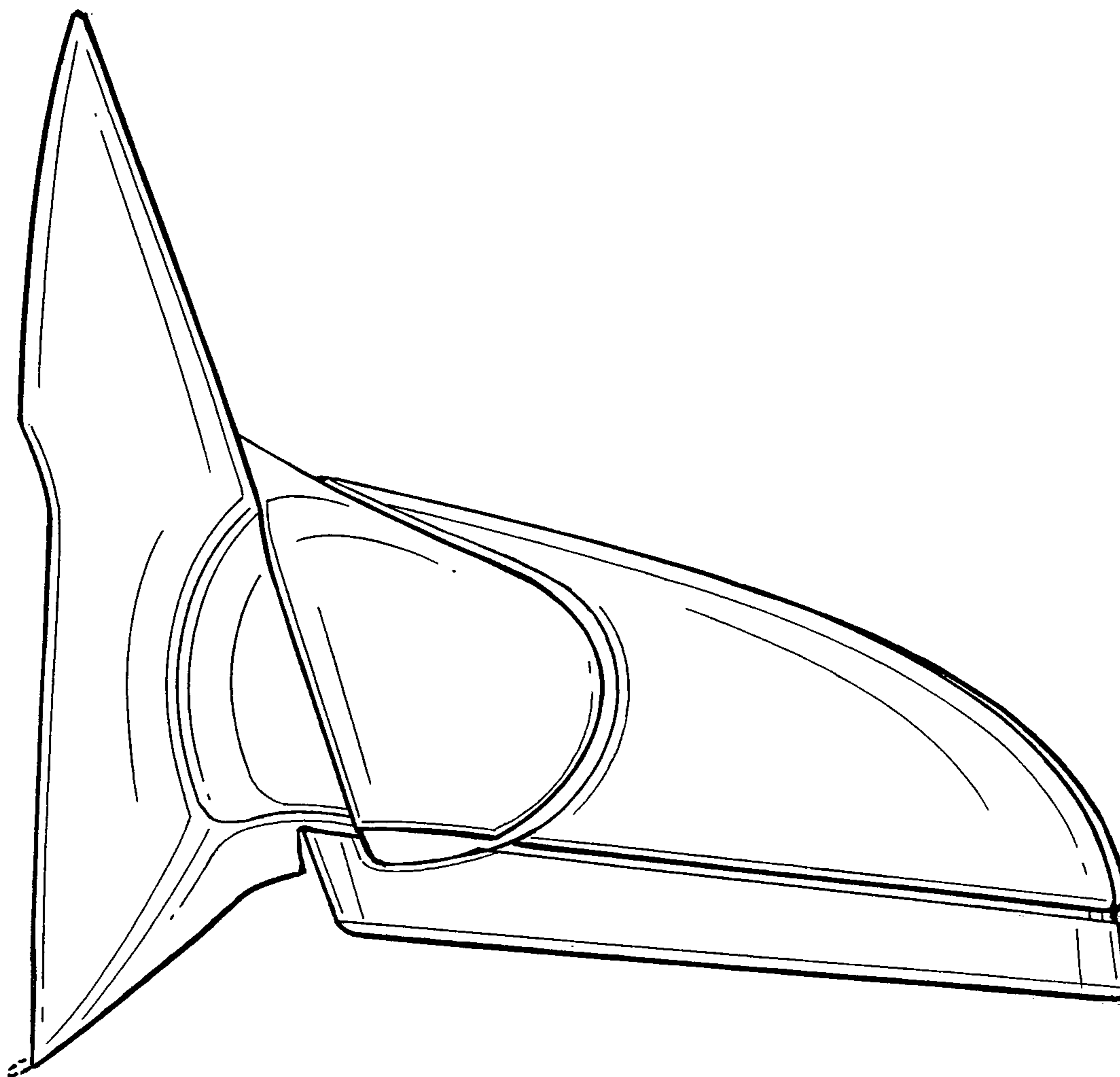

FIG. 7

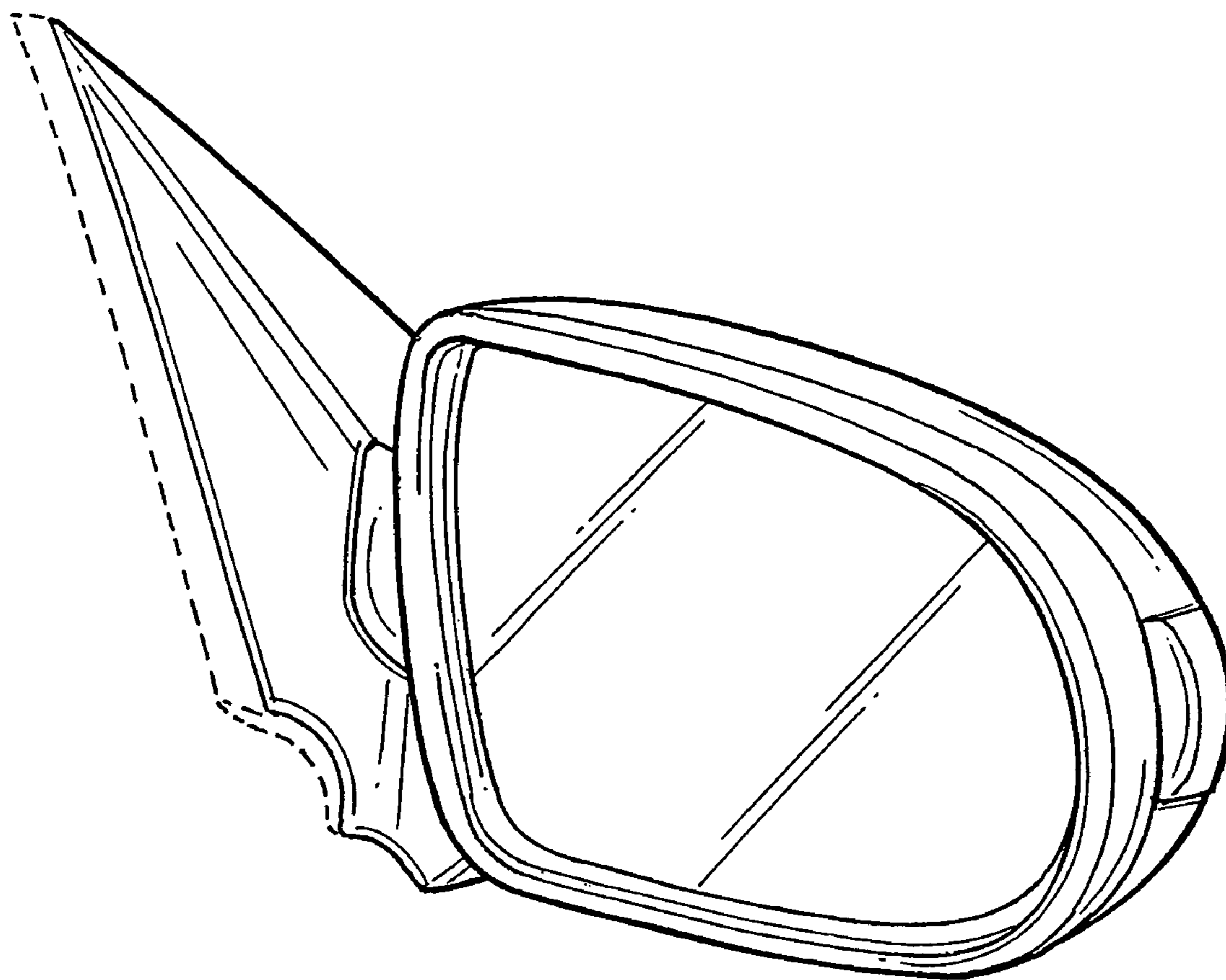

FIG. 8

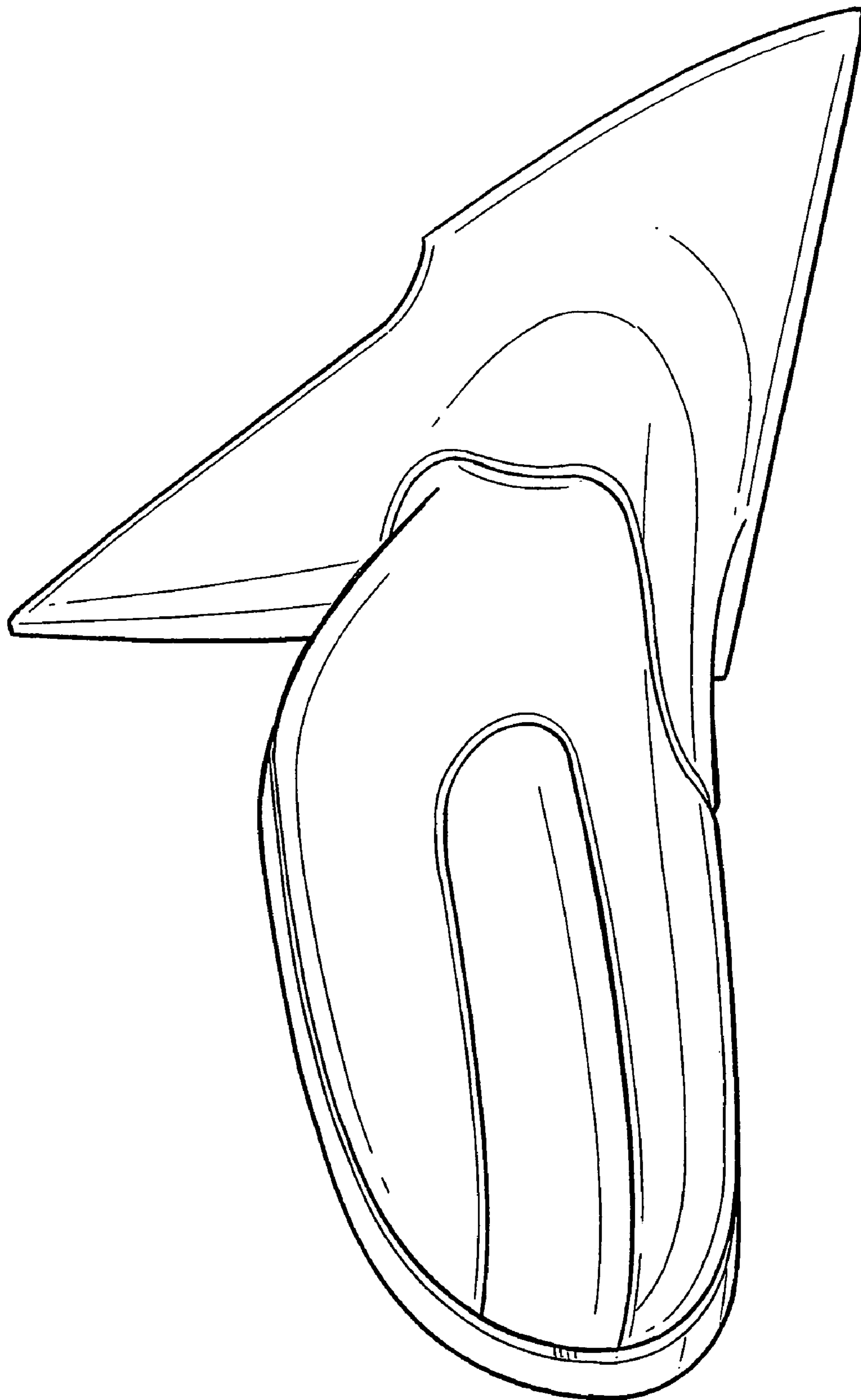

FIG. 9

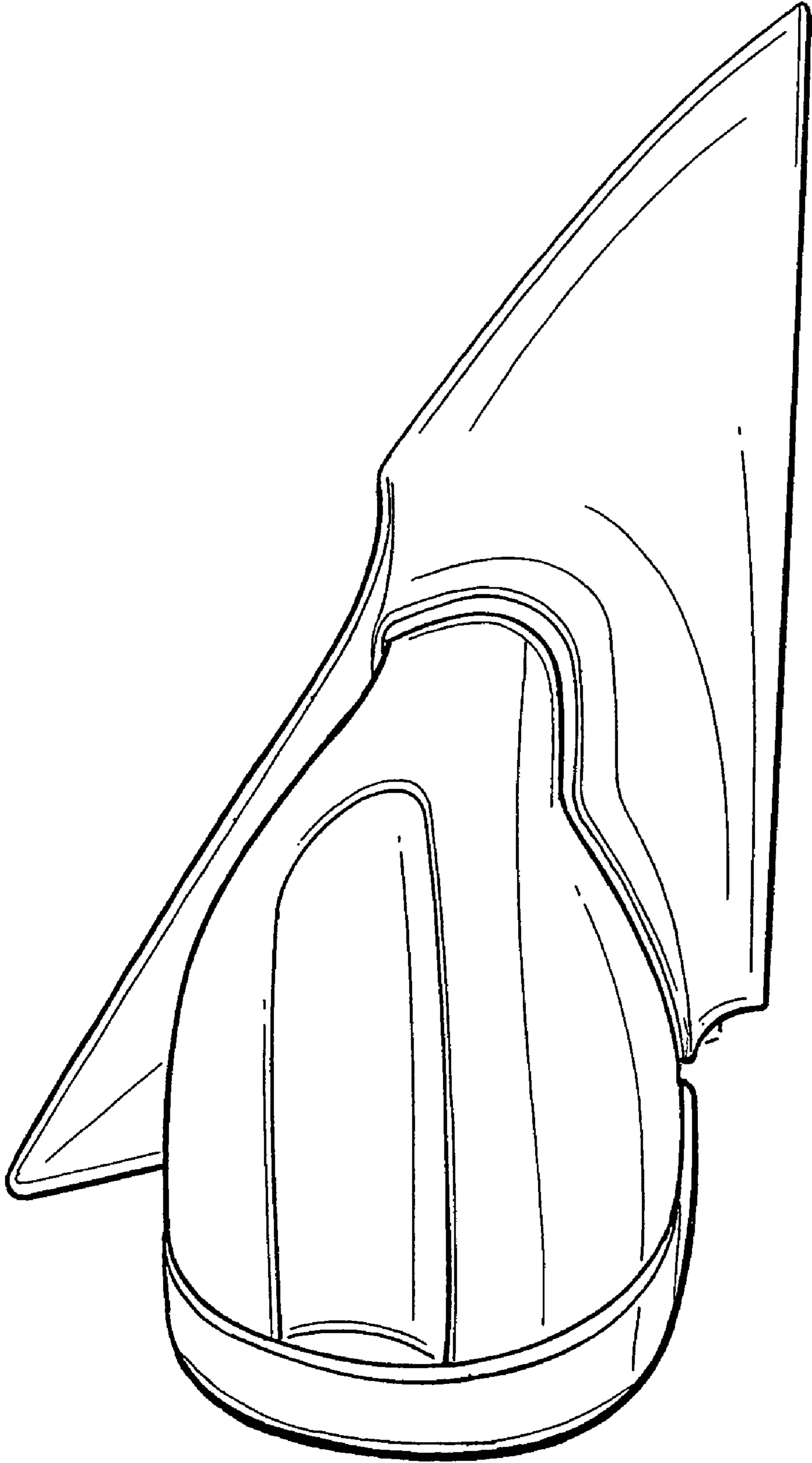

FIG. 10

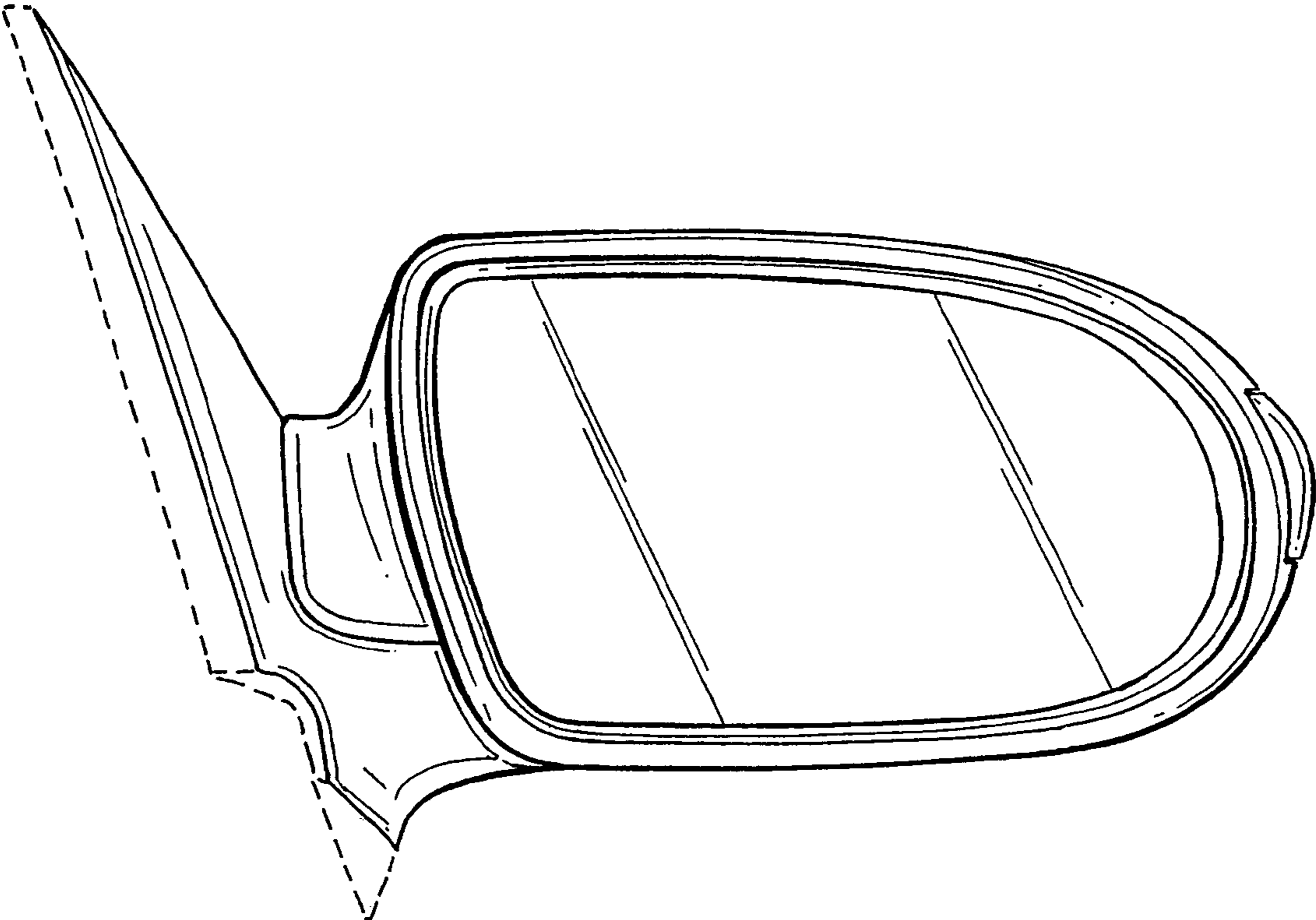

FIG .11

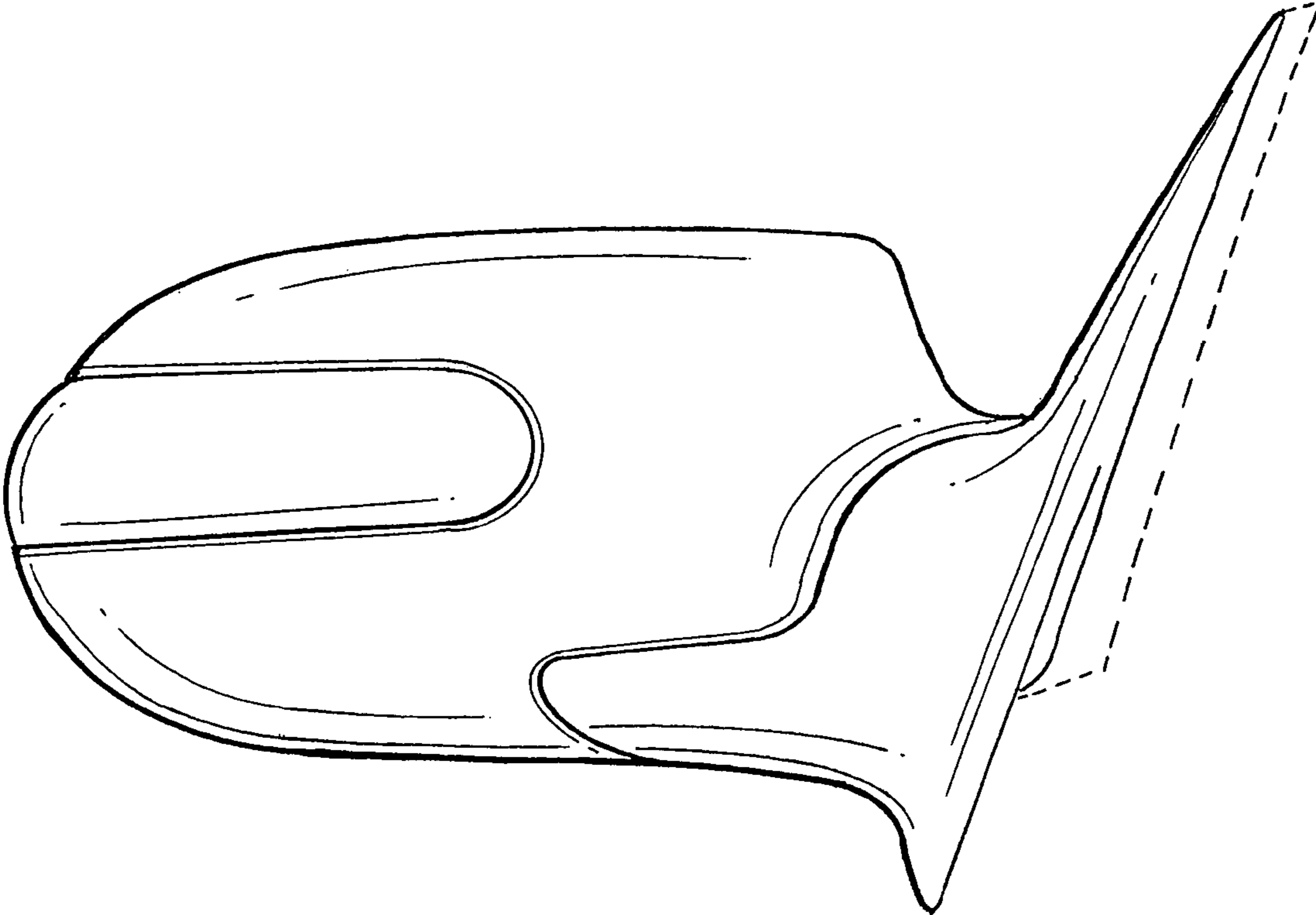

FIG .12

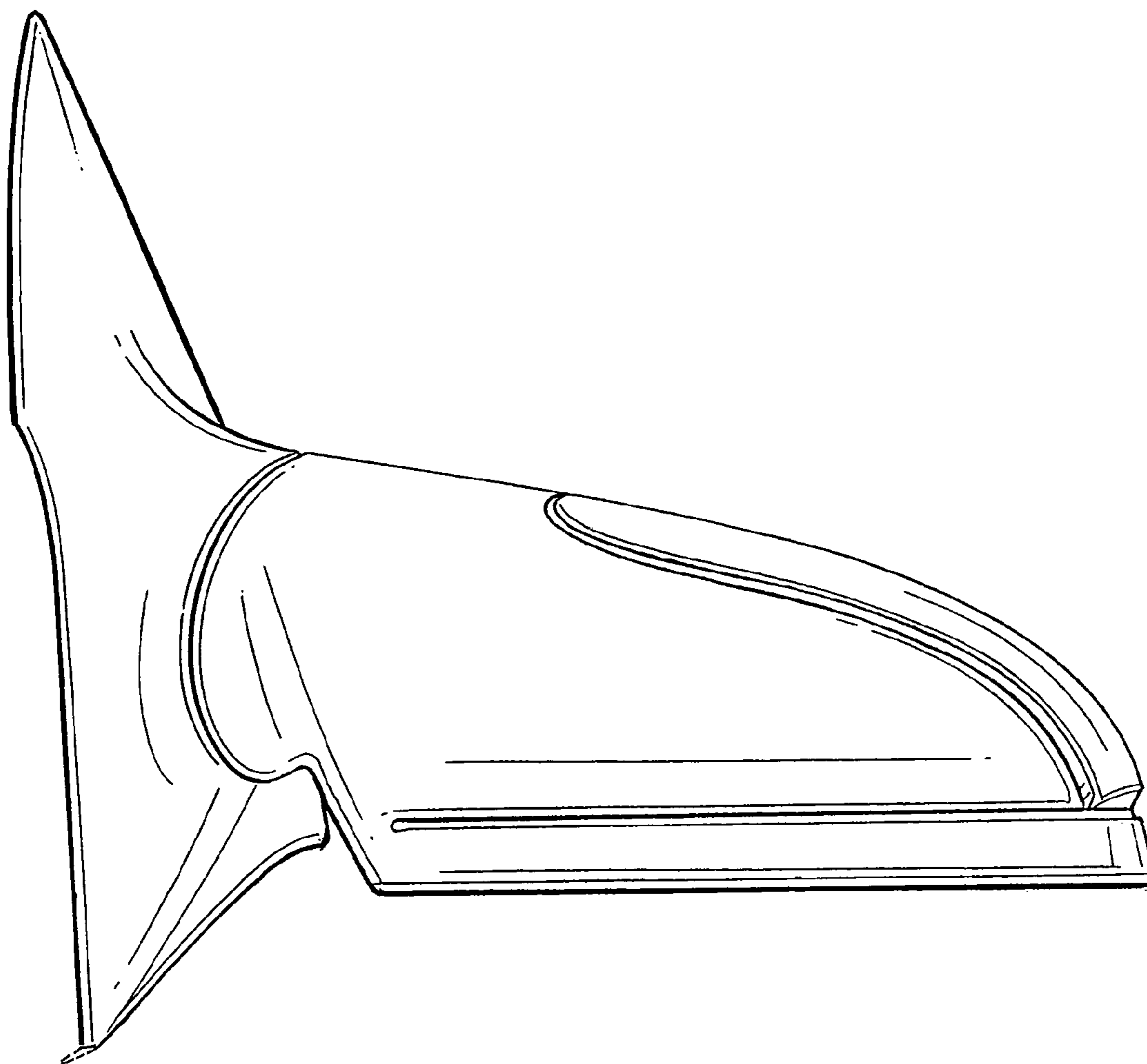

FIG. 13

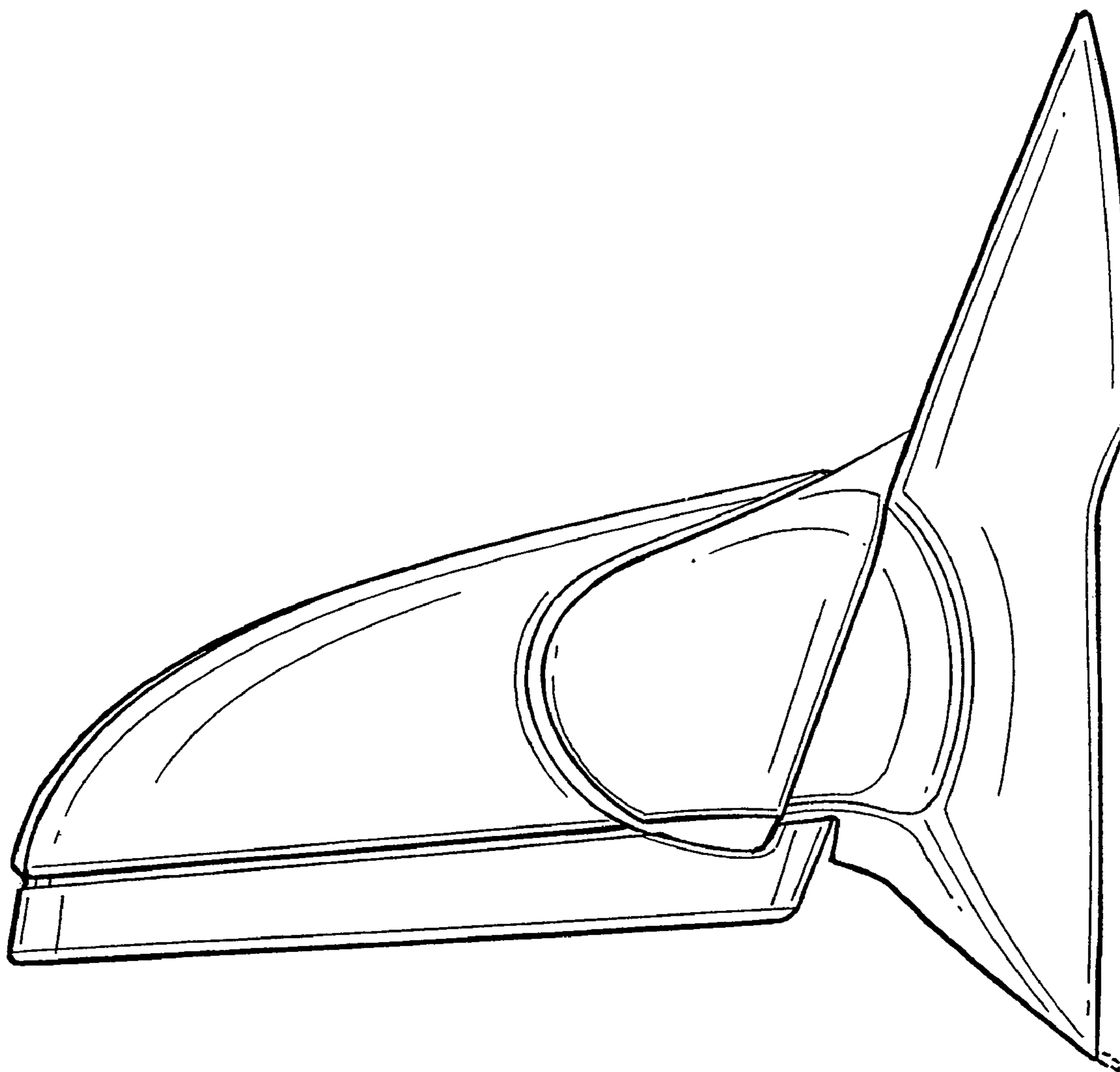

FIG. 14