



US00D586260S

(12) **United States Design Patent**  
**Burns**

(10) **Patent No.:** **US D586,260 S**  
(45) **Date of Patent:** **\*\* Feb. 10, 2009**

(54) **OFF-ROAD VEHICLE FRAME**

(76) Inventor: **John Burns**, 3829 E. Augusta Ct., Queen Creek, AZ (US) 85242

(\*\*) Term: **14 Years**

(21) Appl. No.: **29/296,568**

(22) Filed: **Oct. 23, 2007**

**Related U.S. Application Data**

(63) Continuation-in-part of application No. 29/279,917, filed on May 10, 2007.

(51) **LOC (9) Cl.** ..... **12-08**

(52) **U.S. Cl.** ..... **D12/87**

(58) **Field of Classification Search** ..... D12/86,  
D12/87, 88, 90-92; D21/424, 433, 434;  
180/298, 312; 296/181.1, 181.5  
See application file for complete search history.

(56) **References Cited**

**U.S. PATENT DOCUMENTS**

D253,407	S	*	11/1979	Moore et al.	.....	D12/112
4,217,970	A	*	8/1980	Chika	.....	180/298
D268,746	S	*	4/1983	Greenhalgh et al.	.....	D12/88
4,614,249	A	*	9/1986	Yamanaka	.....	180/312
D286,760	S	*	11/1986	Ooba et al.	.....	D12/87
D299,705	S	*	2/1989	Carpanelli et al.	.....	D12/88
4,810,028	A	*	3/1989	Henricks	.....	296/187.03
D301,849	S	*	6/1989	Oba et al.	.....	D12/87
D408,869	S	*	4/1999	Patmont	.....	D21/433
D446,263	S	*	8/2001	Heys	.....	D21/477
6,623,067	B2	*	9/2003	Gabbianelli et al.	.....	296/205
D500,707	S	*	1/2005	Lu	.....	D12/87
D535,215	S	*	1/2007	Turner et al.	.....	D12/87
D549,133	S	*	8/2007	LePage	.....	D12/87

7,322,106	B2	*	1/2008	Marando et al.	.....	29/897.2
D564,410	S	*	3/2008	Lepage	.....	D12/87
D574,297	S	*	8/2008	Carl	.....	D12/87
2007/0000715	A1	*	1/2007	Denney	.....	180/311
2007/0240927	A1	*	10/2007	Kitai et al.	.....	180/312

\* cited by examiner

*Primary Examiner*—Sandra Snapp

*Assistant Examiner*—Patricia Palasik

(74) *Attorney, Agent, or Firm*—Schmeiser, Olsen & Watts, LLP

(57) **CLAIM**

The ornamental design for the off-road vehicle frame, as shown.

**DESCRIPTION**

FIG. 1 is a side perspective view of the off-road vehicle frame; FIG. 2 is another side perspective view of the off-road vehicle frame;

FIG. 3 is a front side elevation of the off-road vehicle frame; FIG. 4 is a driver's side elevation of the off-road vehicle frame;

FIG. 5 is a rear side elevation of the off-road vehicle frame; FIG. 6 is a passenger's side elevation of the off-road vehicle frame;

FIG. 7 is a top plan view of the off-road vehicle frame; FIG. 8 is a bottom plan view of the off-road vehicle frame; FIG. 9 is a bottom perspective view of the off-road vehicle frame; and,

FIG. 10 is another bottom perspective view of the off-road vehicle frame.

**1 Claim, 10 Drawing Sheets**

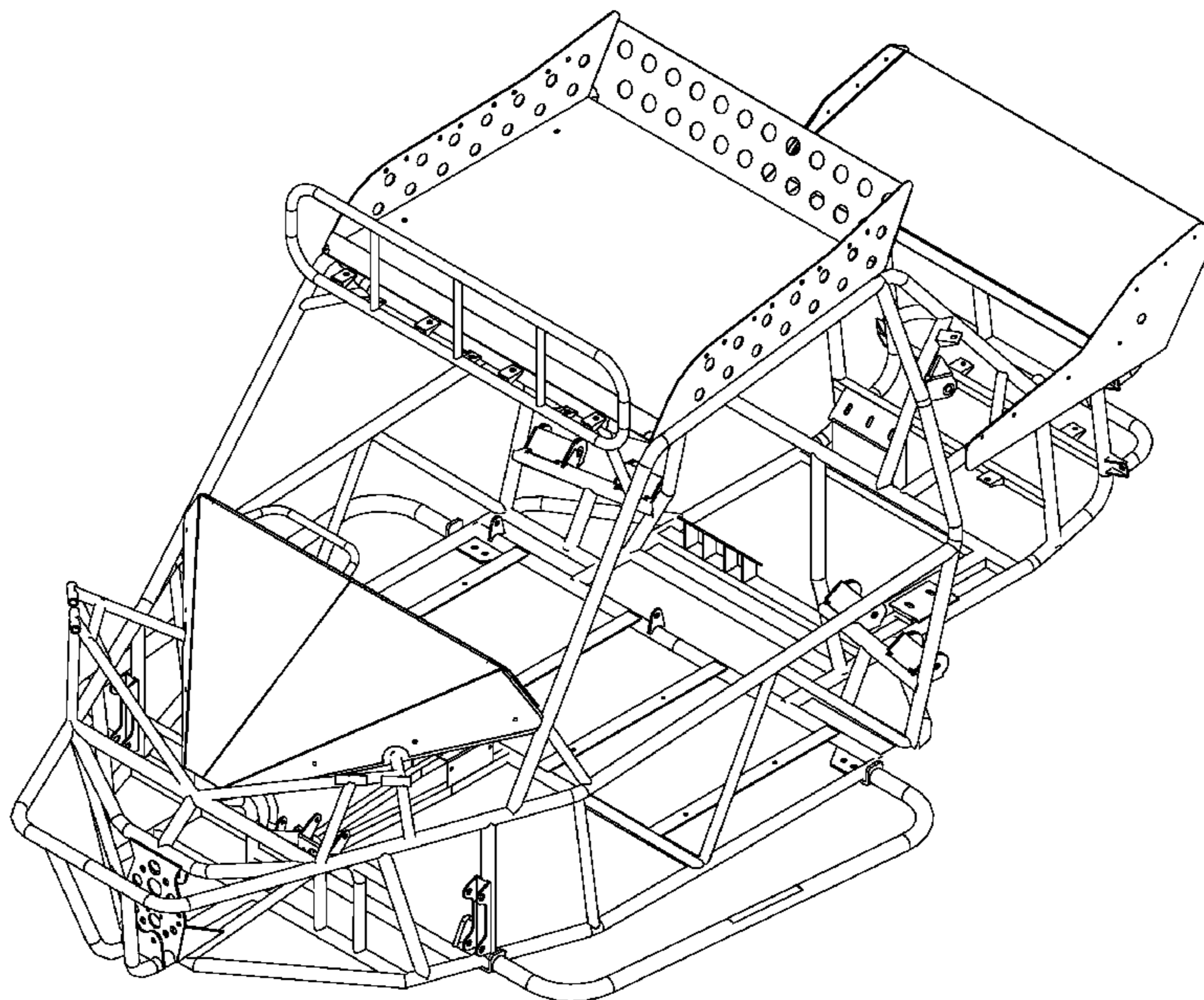

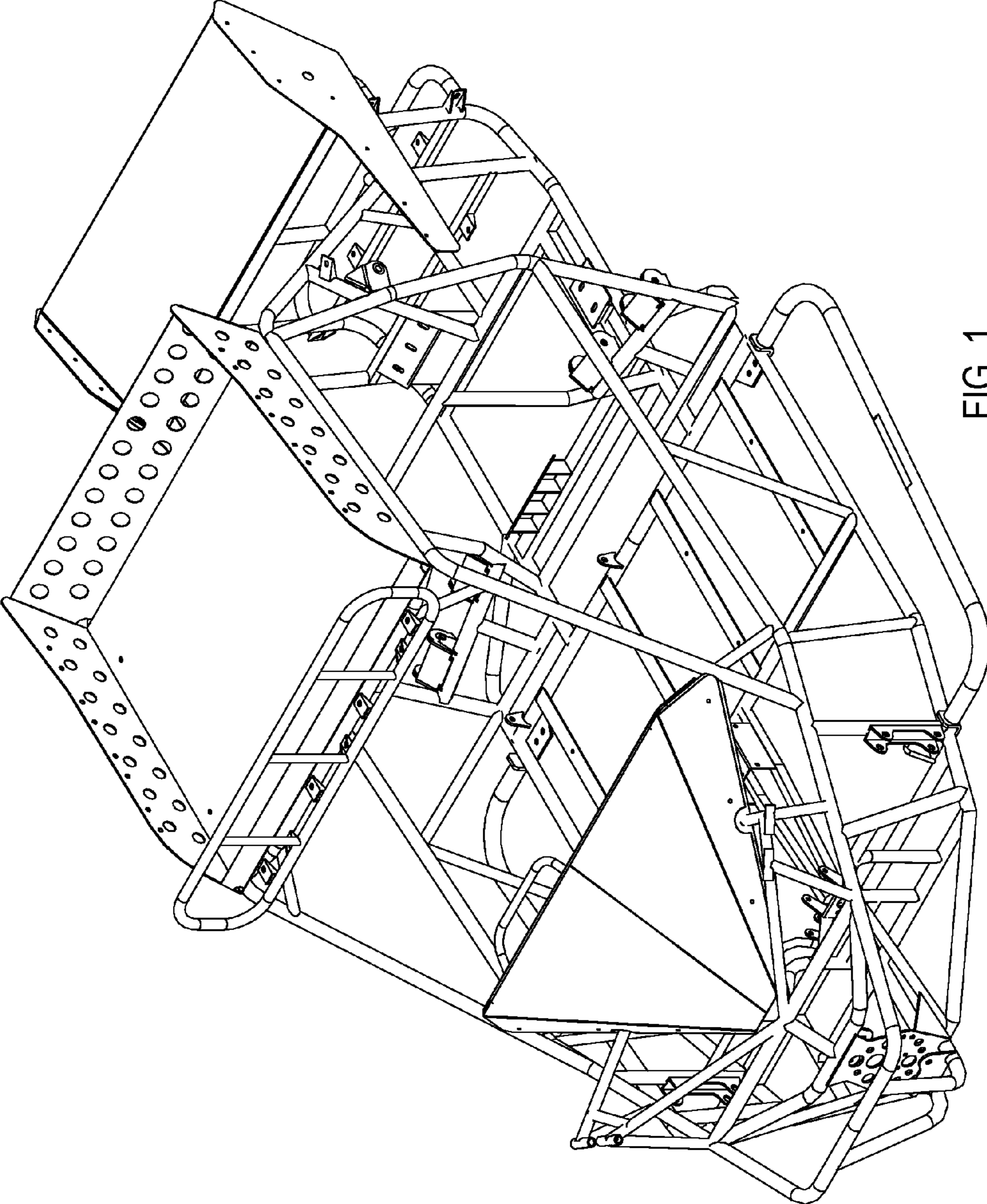

FIG. 1

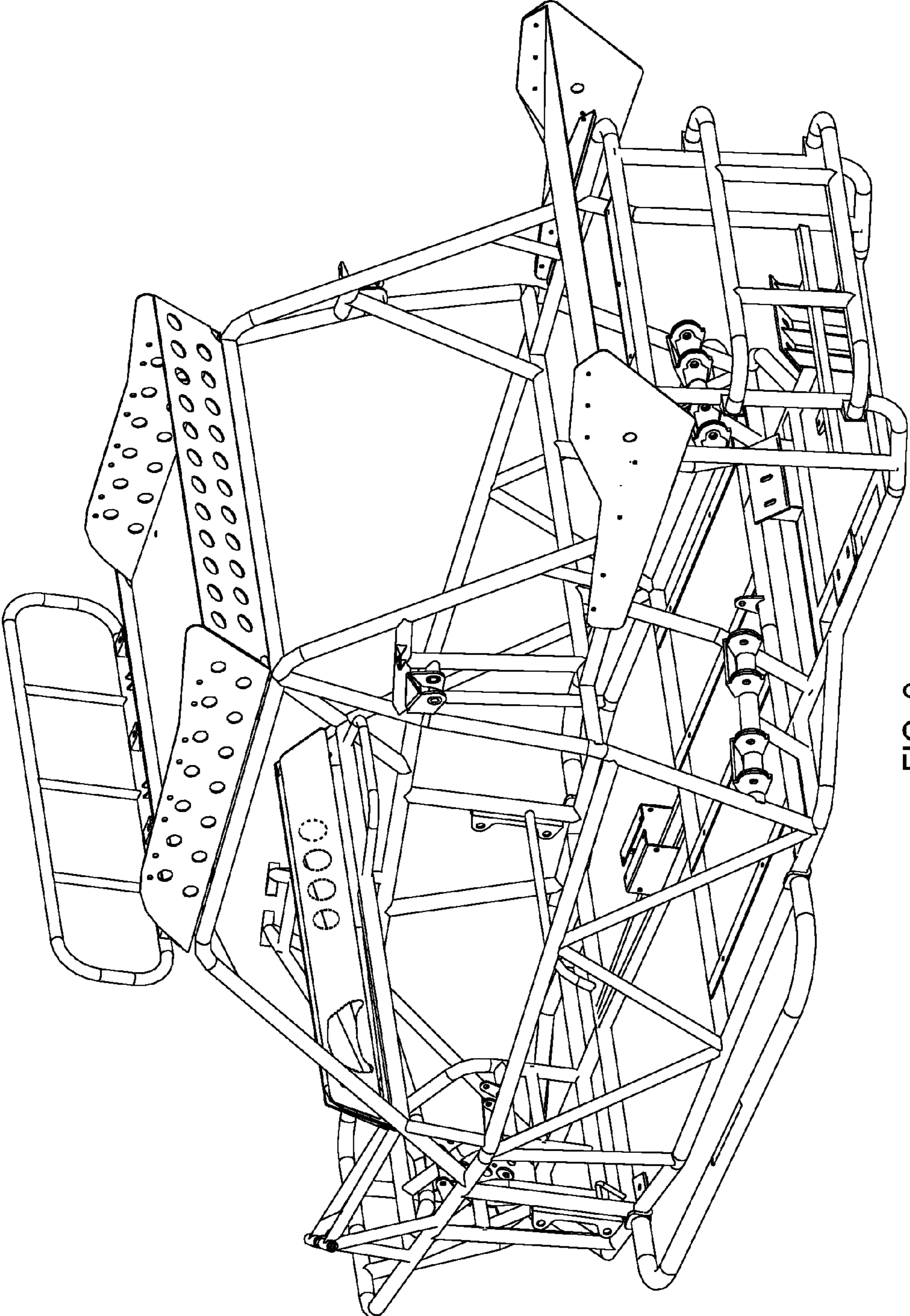

FIG. 2

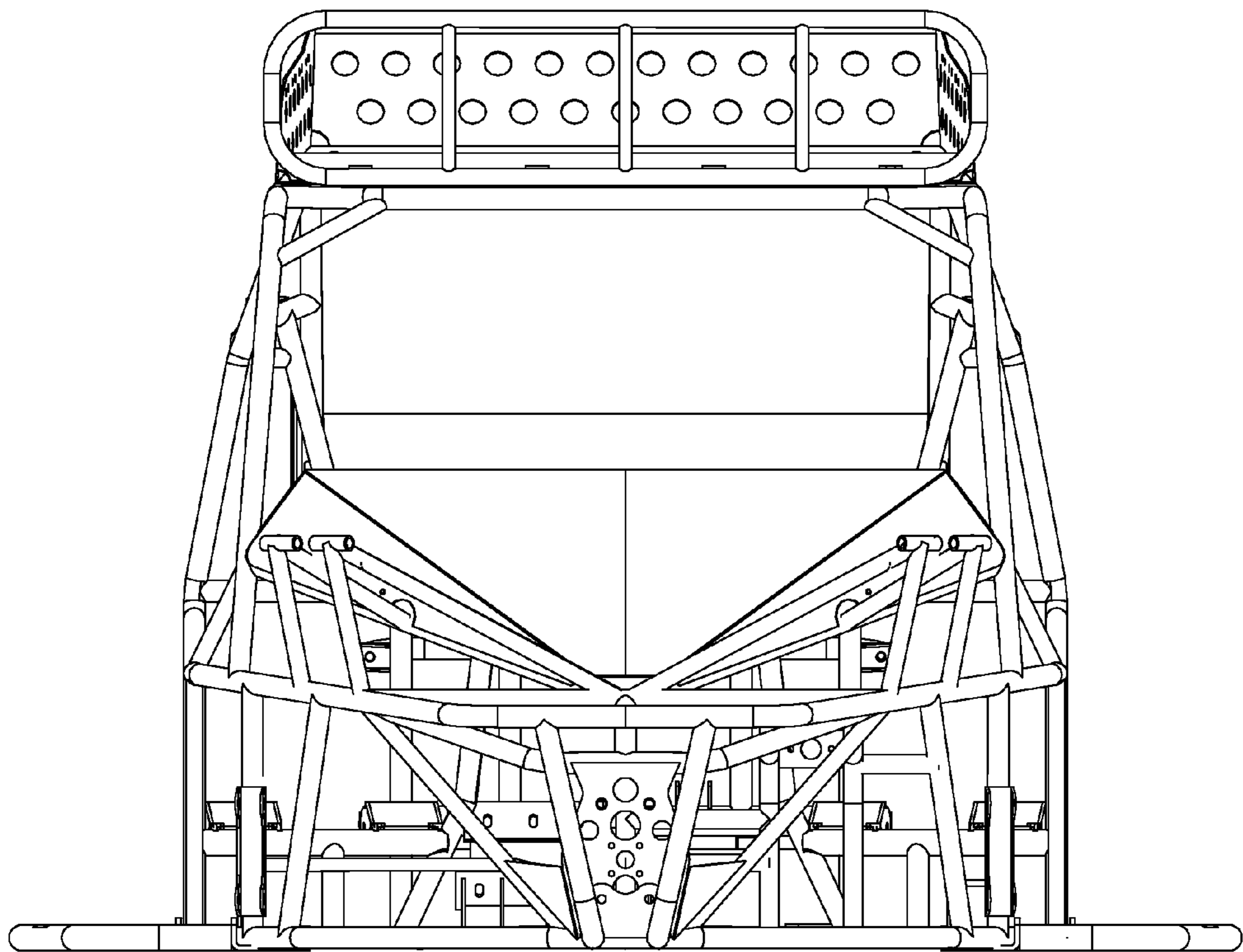

FIG. 3

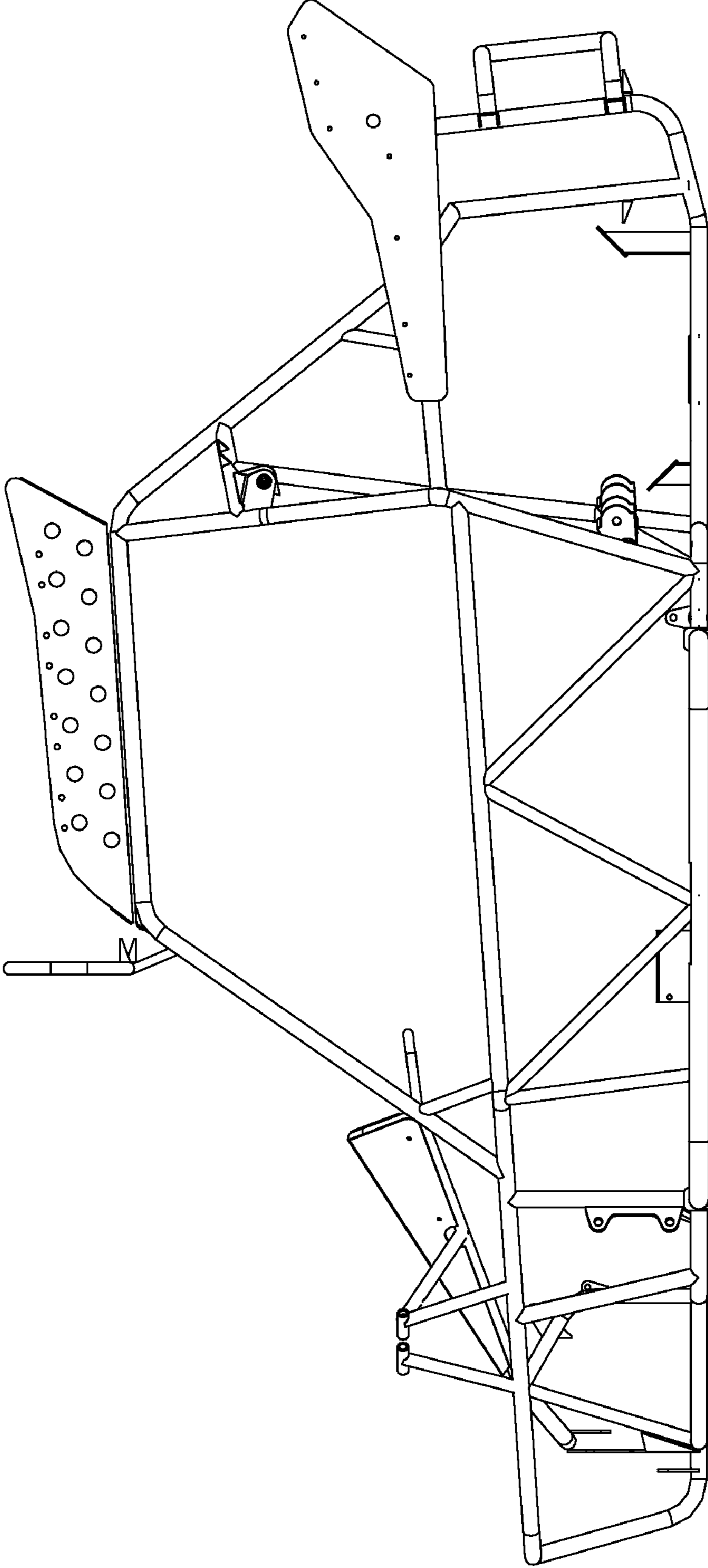

FIG. 4

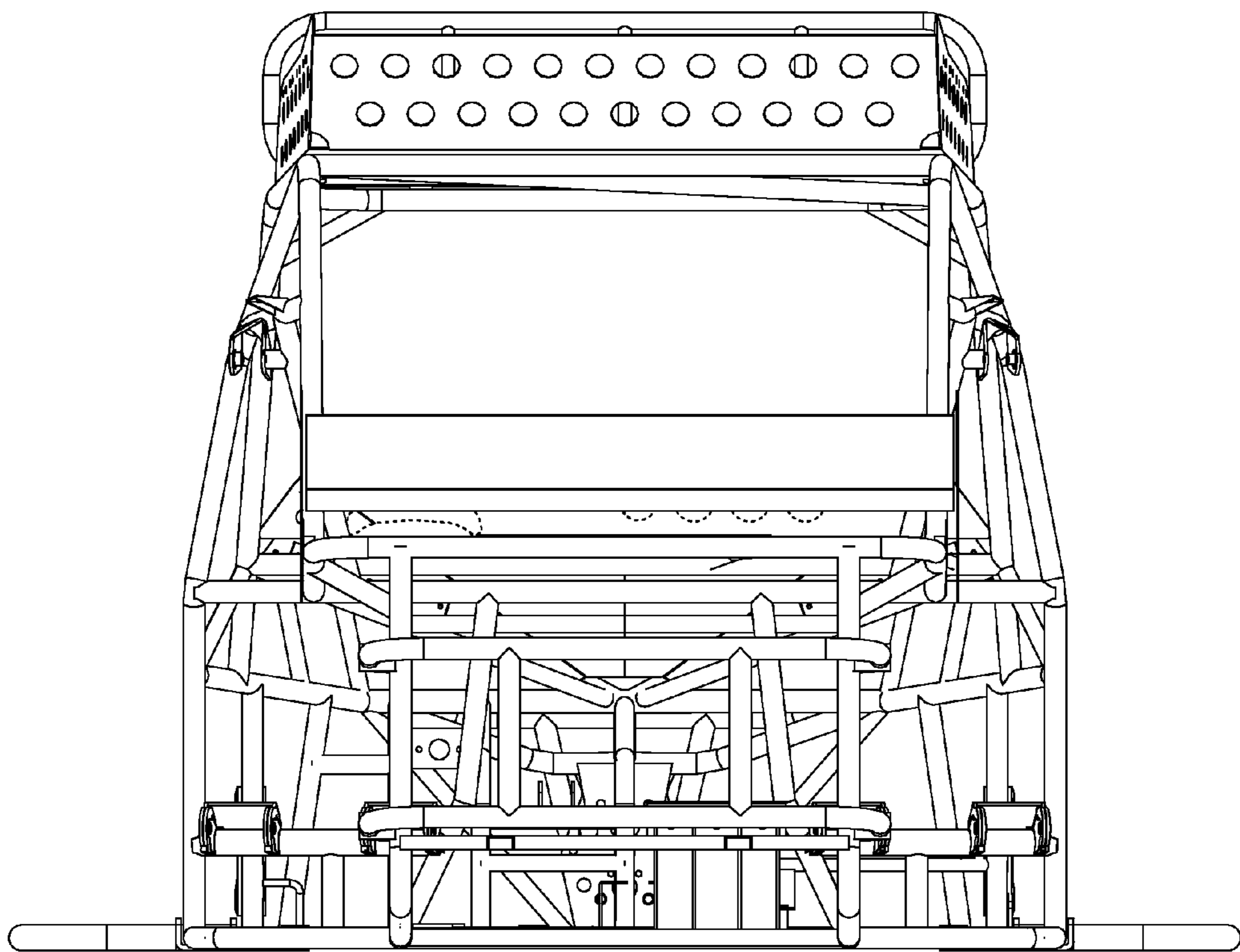

FIG. 5

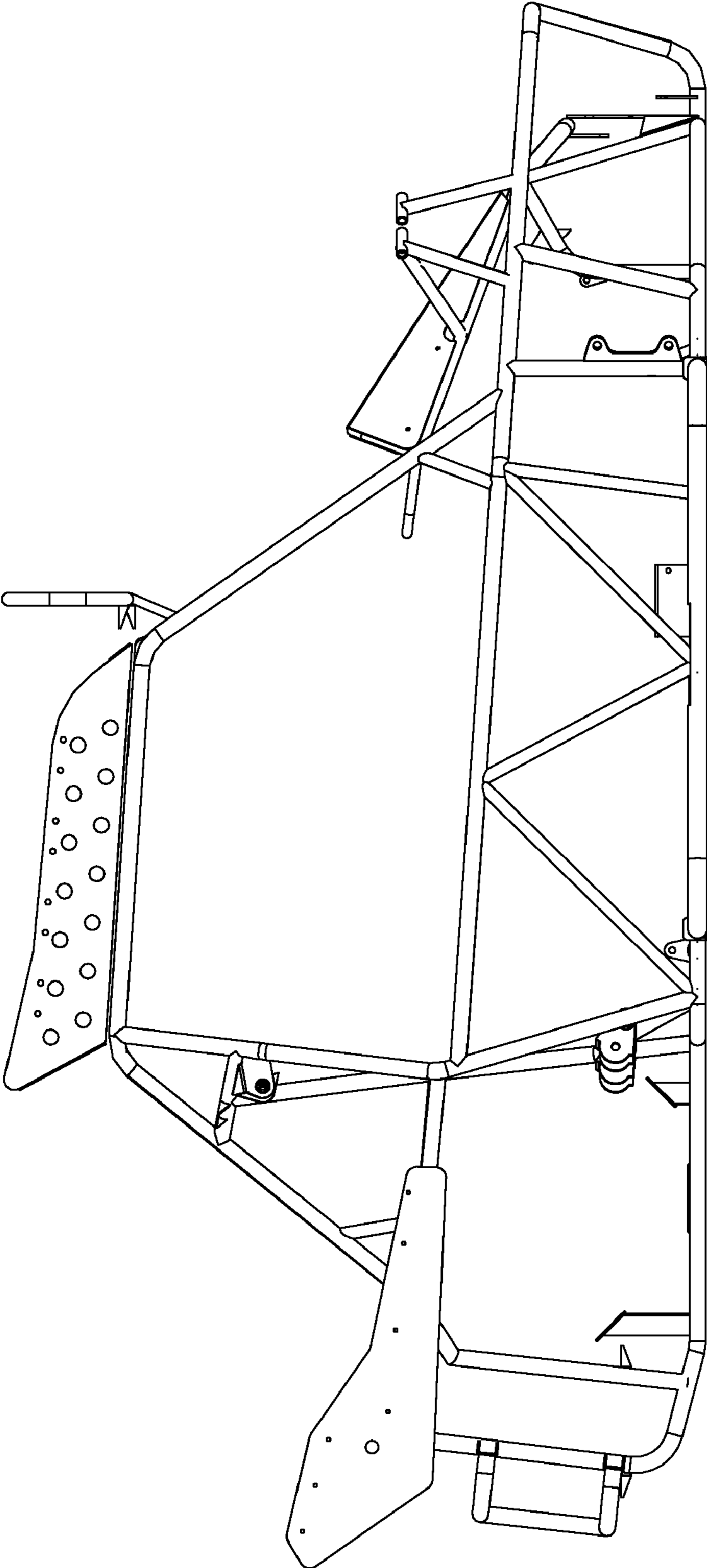

FIG. 6

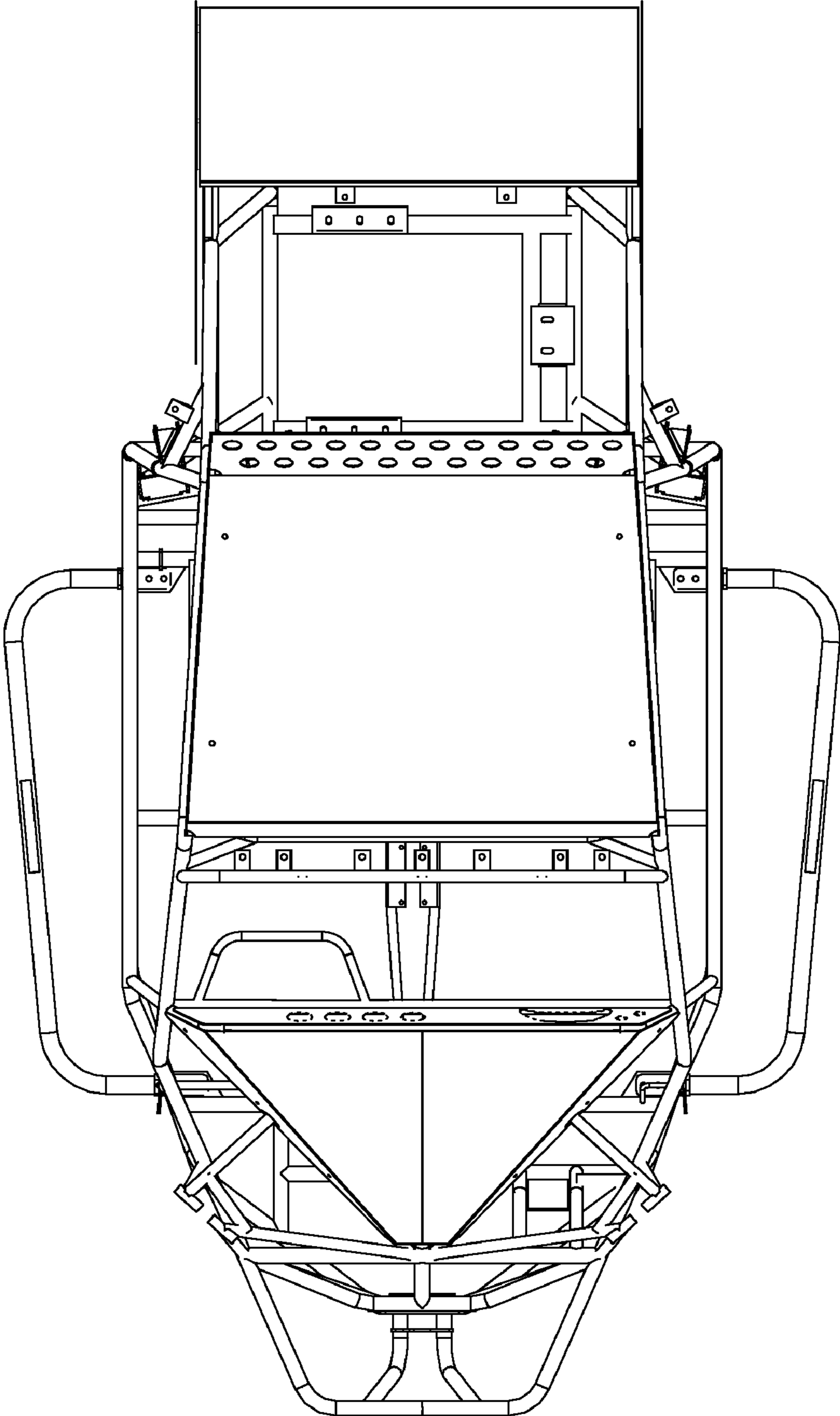

FIG. 7



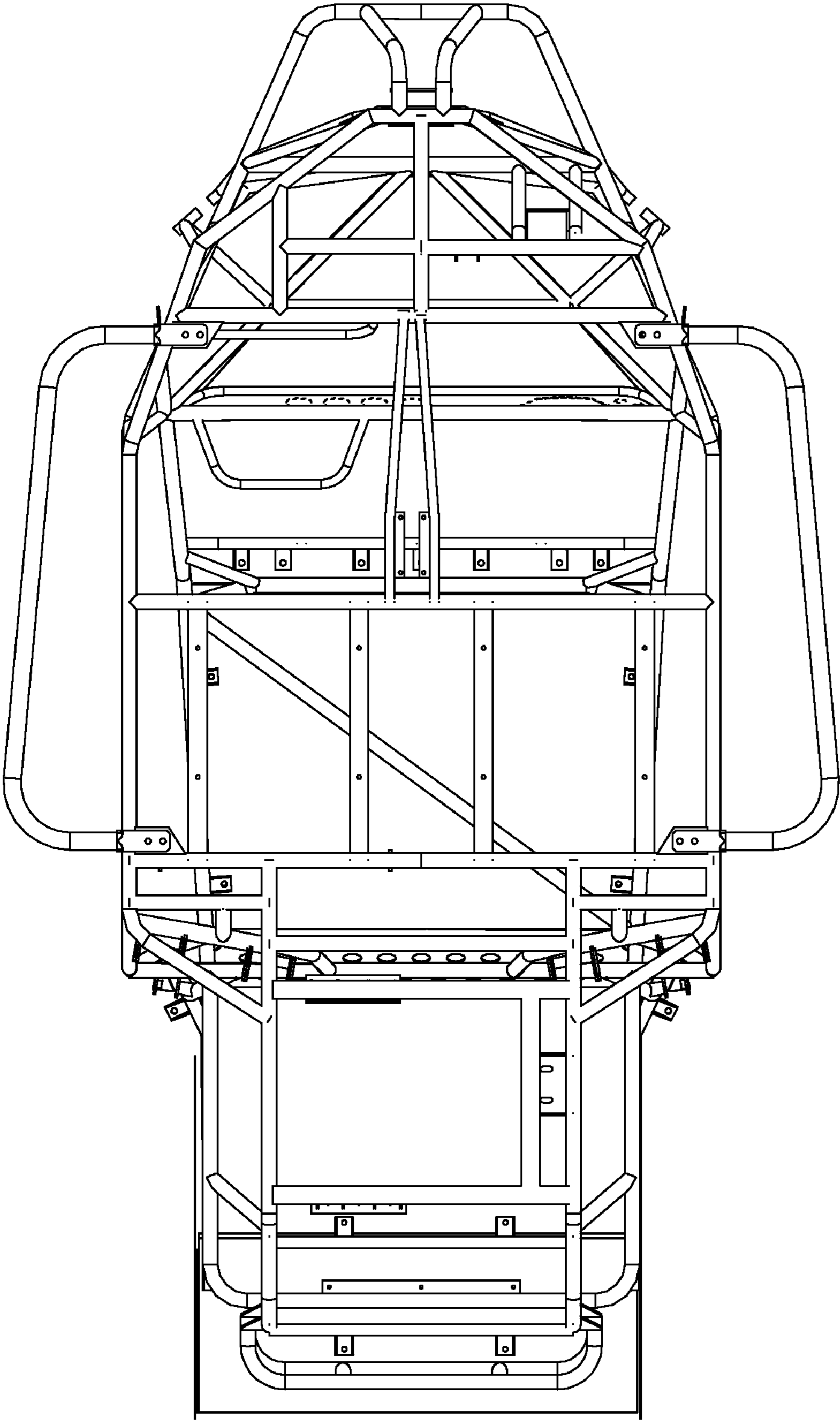

FIG. 8

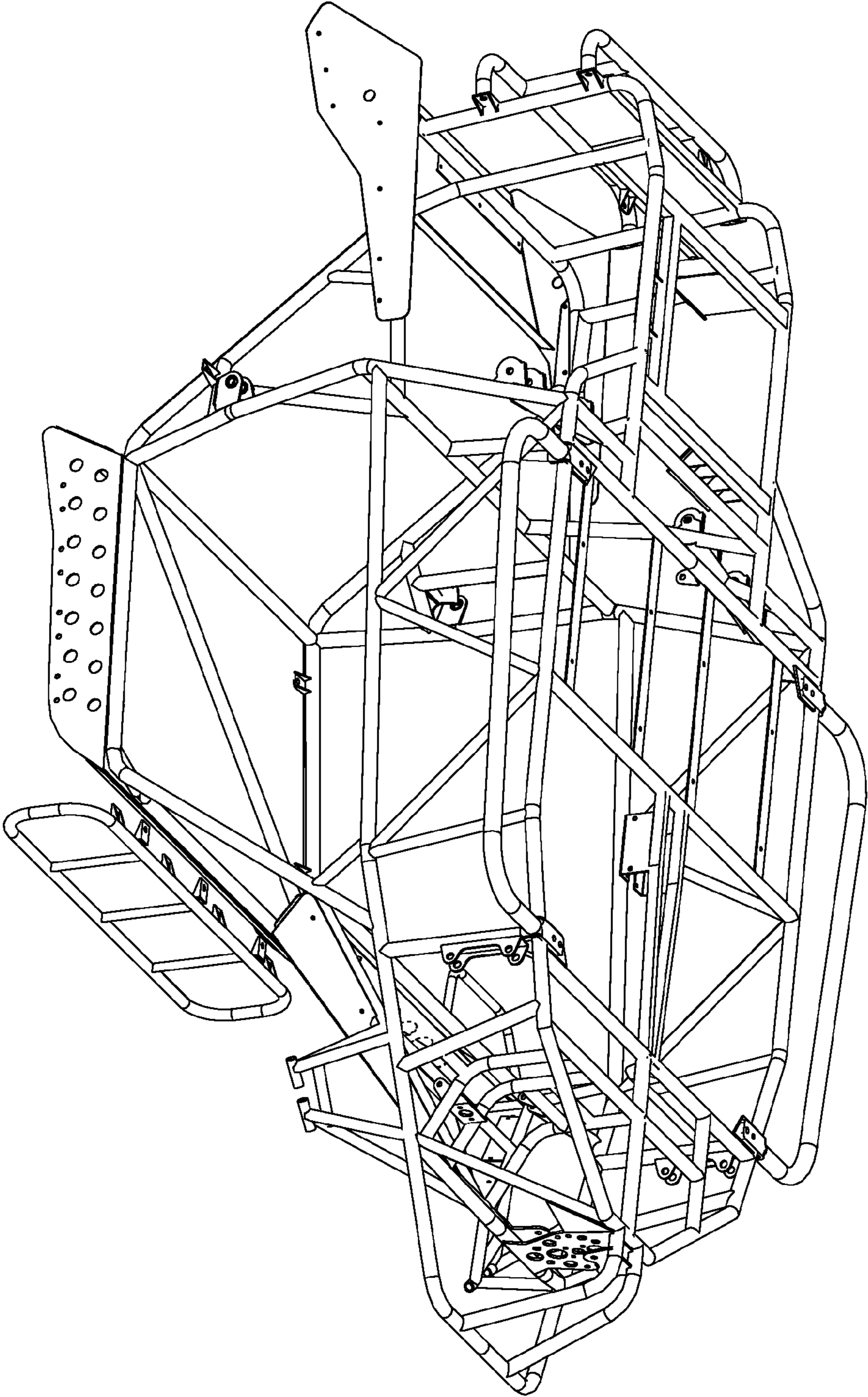

FIG. 9

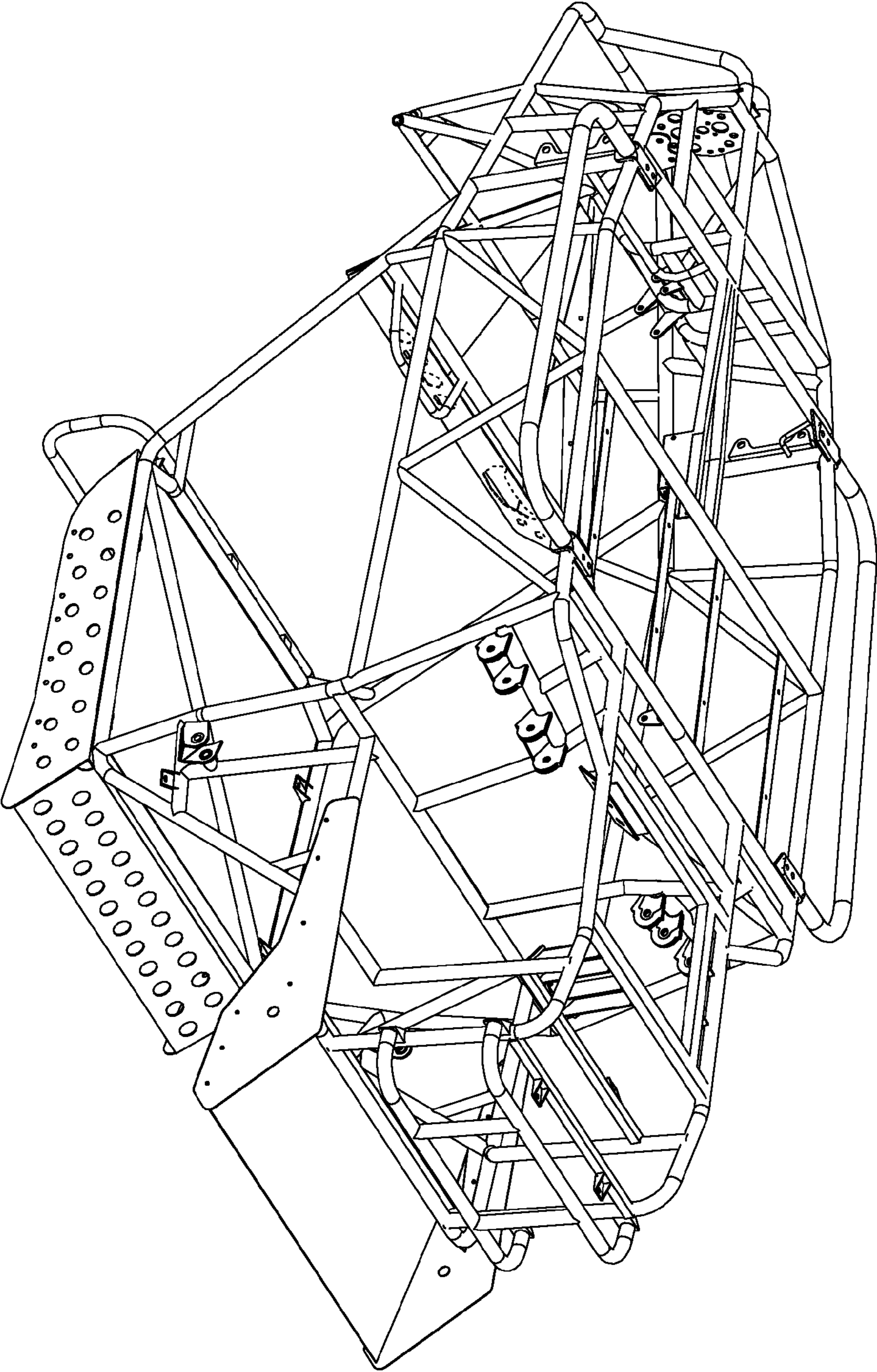

FIG. 10