



US00D586182S

(12) **United States Design Patent**
Trombly

(10) **Patent No.:** **US D586,182 S**

(45) **Date of Patent:** **** Feb. 10, 2009**

(54) **MUG**

(75) Inventor: **Edgar Trombly**, Grosse Pointe Farms, MI (US)

(73) Assignee: **Punch Products USA, Inc.**, Rahway, NJ (US)

(**) Term: **14 Years**

(21) Appl. No.: **29/267,114**

(22) Filed: **Oct. 5, 2006**

(51) **LOC (9) Cl.** **07-01**

(52) **U.S. Cl.** **D7/510; D7/509**

(58) **Field of Classification Search** D7/392.1, D7/500, 509–511, 523, 533–536, 538, 608, D7/529, 532, 312, 316, 622; 215/387, 200, 215/DIG. 7; 220/592.16, 592.17, 703, 710.5, 220/711, 612, 719, 298; D9/767, 773, 774, D9/776, 7, 519, 537, 500, 545; 229/404, 229/402; 62/457.3

See application file for complete search history.

(56) **References Cited**

U.S. PATENT DOCUMENTS

D96,707	S	*	8/1935	Solomon	D11/152
2,051,446	A	*	8/1936	Ice	215/12.1
2,319,487	A	*	5/1943	Baldwin, Jr.	220/612
D177,559	S	*	5/1956	Emmert	D7/531
2,801,541	A	*	8/1957	Moreland	73/319
2,863,585	A	*	12/1958	Meshberg	220/592.17
2,899,098	A	*	8/1959	Gits	220/592.17
D203,629	S	*	2/1966	Brock	D9/780
4,136,799	A	*	1/1979	Albert	220/298
D286,604	S	*	11/1986	Bierlein et al.	D7/523
5,067,922	A	*	11/1991	McMahon	446/71
D324,281	S	*	2/1992	Brussing	D34/1
5,228,585	A	*	7/1993	Lutgen et al.	220/4.14
D376,284	S	*	12/1996	Keeley	D6/520
D417,819	S	*	12/1999	Kelly-Pollet	D7/510
6,073,868	A	*	6/2000	Stevens et al.	242/118.32
6,185,808	B1	*	2/2001	Ranze et al.	29/455.1
6,732,964	B2	*	5/2004	Couchey	242/118.32

* cited by examiner

Primary Examiner—Philip Hyder

Assistant Examiner—Cynthia Underwood

(74) *Attorney, Agent, or Firm*—Baker Botts L.L.P.

(57) **CLAIM**

The ornamental design of a mug, as shown and described.

DESCRIPTION

FIG. 1 is a perspective view of a first embodiment of the invention;

FIG. 2 is a front view of the embodiment of FIG. 1, with the side and rear views being identical to the front view;

FIG. 3 is a top view of the embodiment of FIG. 1;

FIG. 4 is a bottom view of the embodiment of FIG. 1;

FIG. 5 is a perspective view of a second embodiment of the invention in a two-color contrast combination;

FIG. 6 is a front view of the embodiment of FIG. 5, with the side and rear views being identical to the front view;

FIG. 7 is a top view of the embodiment of FIG. 5;

FIG. 8 is a bottom view of the embodiment of FIG. 5;

FIG. 9 is a perspective view of a third embodiment of the invention in a two-color contrast combination;

FIG. 10 is a front view of the embodiment of FIG. 9, with the side and rear views being identical to the front view;

FIG. 11 is a top view of the embodiment of FIG. 9;

FIG. 12 is a bottom view of the embodiment of FIG. 9;

FIG. 13 is a perspective view of a fourth embodiment of the invention in a white and silver color combination;

FIG. 14 is a front view of the embodiment of FIG. 13, with the side and rear views being identical to the front view;

FIG. 15 is a top view of the embodiment of FIG. 13;

FIG. 16 is a bottom view of the embodiment of FIG. 13;

FIG. 17 is a perspective view of a fifth embodiment of the invention in a black and silver color combination;

FIG. 18 is a front view of the embodiment of FIG. 17, with the side and rear views being identical to the front view;

FIG. 19 is a top view of the embodiment of FIG. 17;

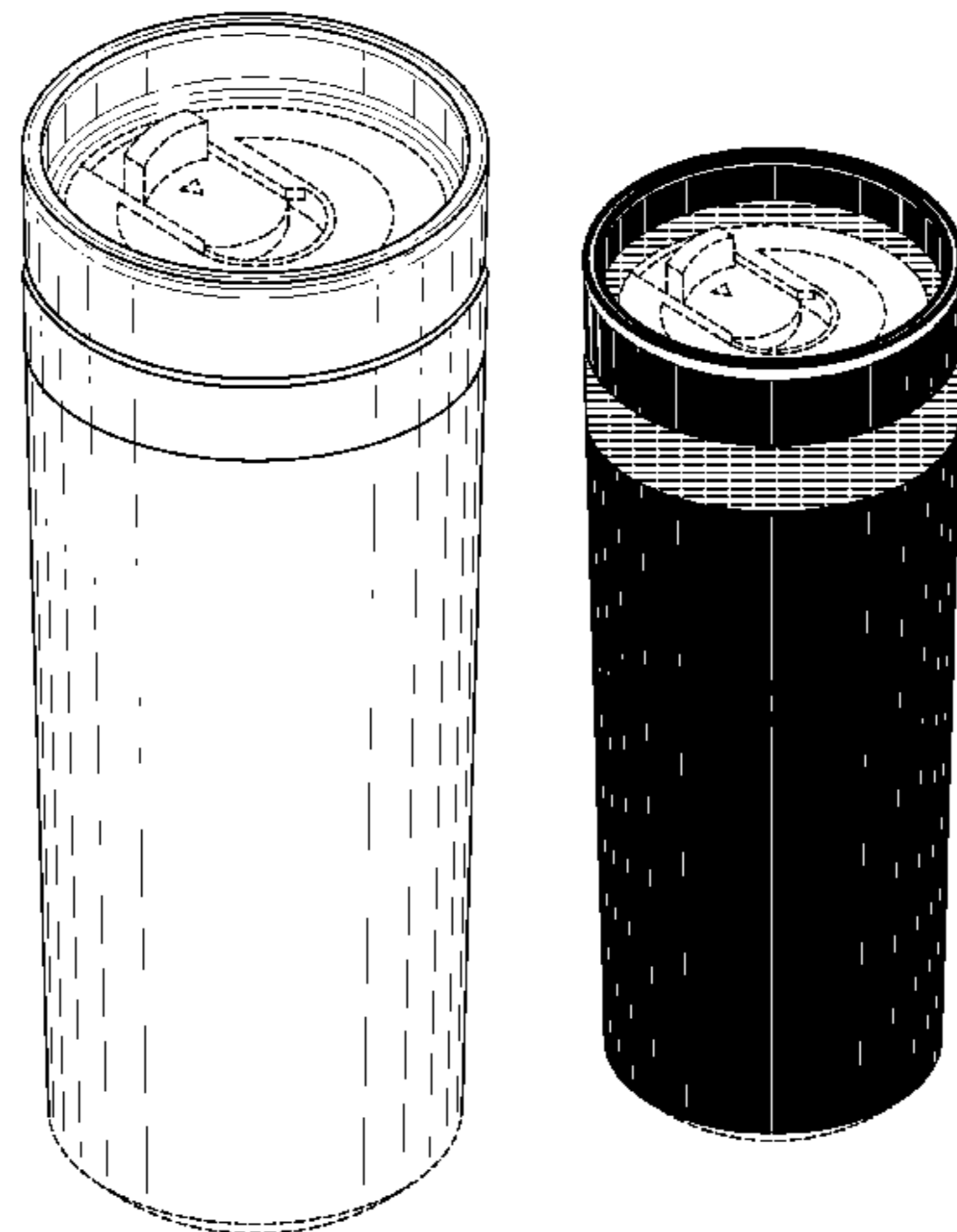

FIG. 20 is a bottom view of the embodiment of FIG. 17;
FIG. 21 is a perspective view of a sixth embodiment of the invention;
FIG. 22 is a front view of the embodiment of FIG. 21, with the side and rear views being identical to the front view;
FIG. 23 is a top view of the embodiment of FIG. 21;
FIG. 24 is a bottom view of the embodiment of FIG. 21;
FIG. 25 is a perspective view of a seventh embodiment of the invention in a two-color contrast combination;
FIG. 26 is a front view of the embodiment of FIG. 25, with the side and rear views being identical to the front view;
FIG. 27 is a top view of the embodiment of FIG. 25;
FIG. 28 is a bottom view of the embodiment of FIG. 25;
FIG. 29 is a perspective view of an eighth embodiment of the invention in a two-color contrast combination;
FIG. 30 is a front view of the embodiment of FIG. 29, with the side and rear views being identical to the front view;

FIG. 31 is a top view of the embodiment of FIG. 29;
FIG. 32 is a bottom view of the embodiment of FIG. 29;
FIG. 33 is a perspective view of a ninth embodiment of the invention in a white and silver color combination;
FIG. 34 is a front view of the embodiment of FIG. 33, with the side and rear views being identical to the front view;
FIG. 35 is a top view of the embodiment of FIG. 33;
FIG. 36 is a bottom view of the embodiment of FIG. 33;
FIG. 37 is a perspective view of a tenth embodiment of the invention in a black and silver color combination;
FIG. 38 is a front view of the embodiment of FIG. 37, with the side and rear views being identical to the front view;
FIG. 39 is a top view of the embodiment of FIG. 37; and,
FIG. 40 is a bottom view of the embodiment of FIG. 37.
The broken lines are provided for illustrative purposes only and form no part of the claimed design.

1 Claim, 10 Drawing Sheets

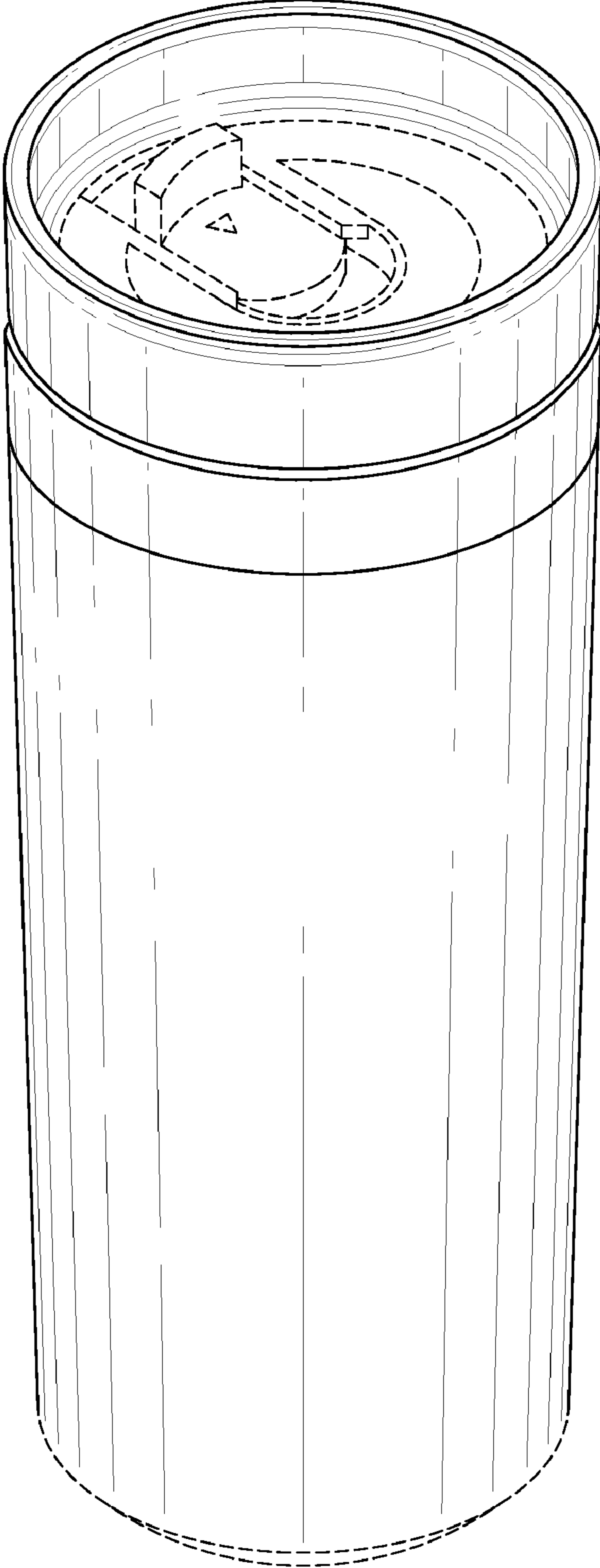

FIG. 1

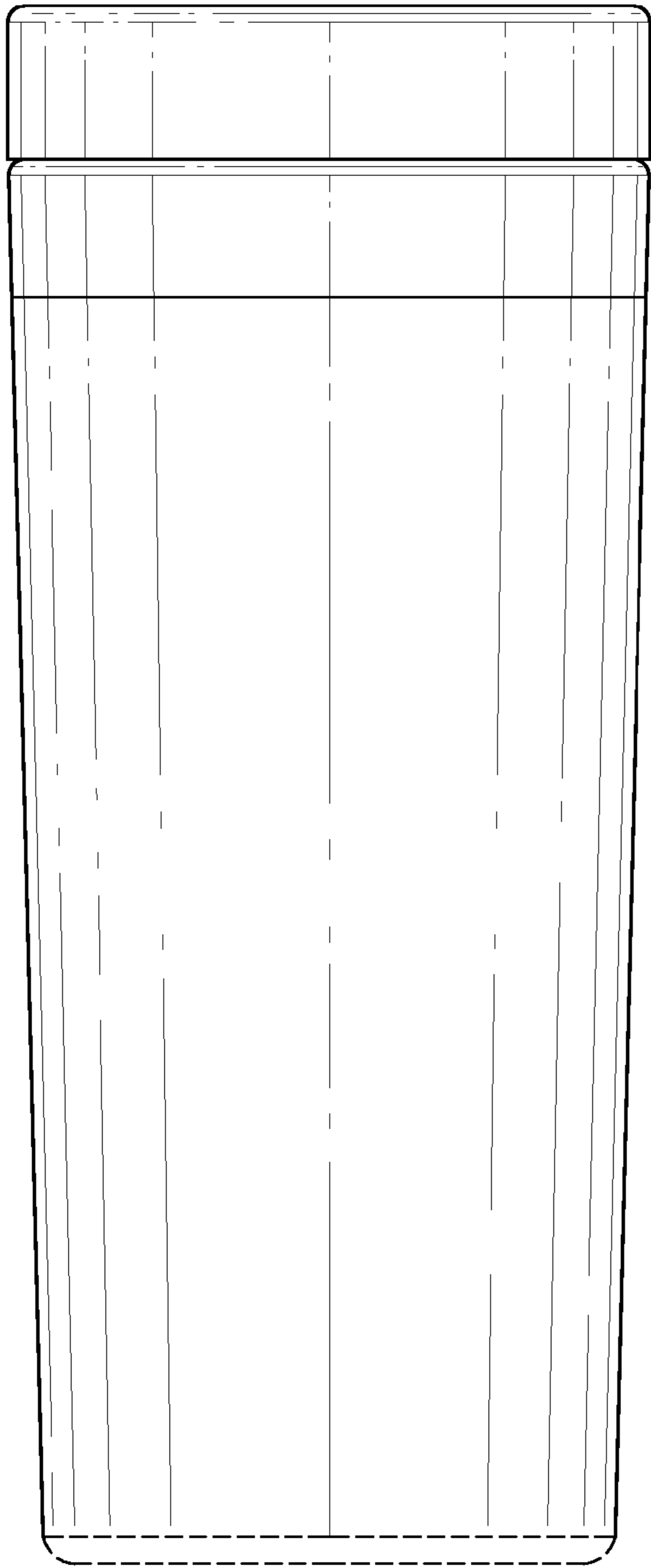

FIG. 2

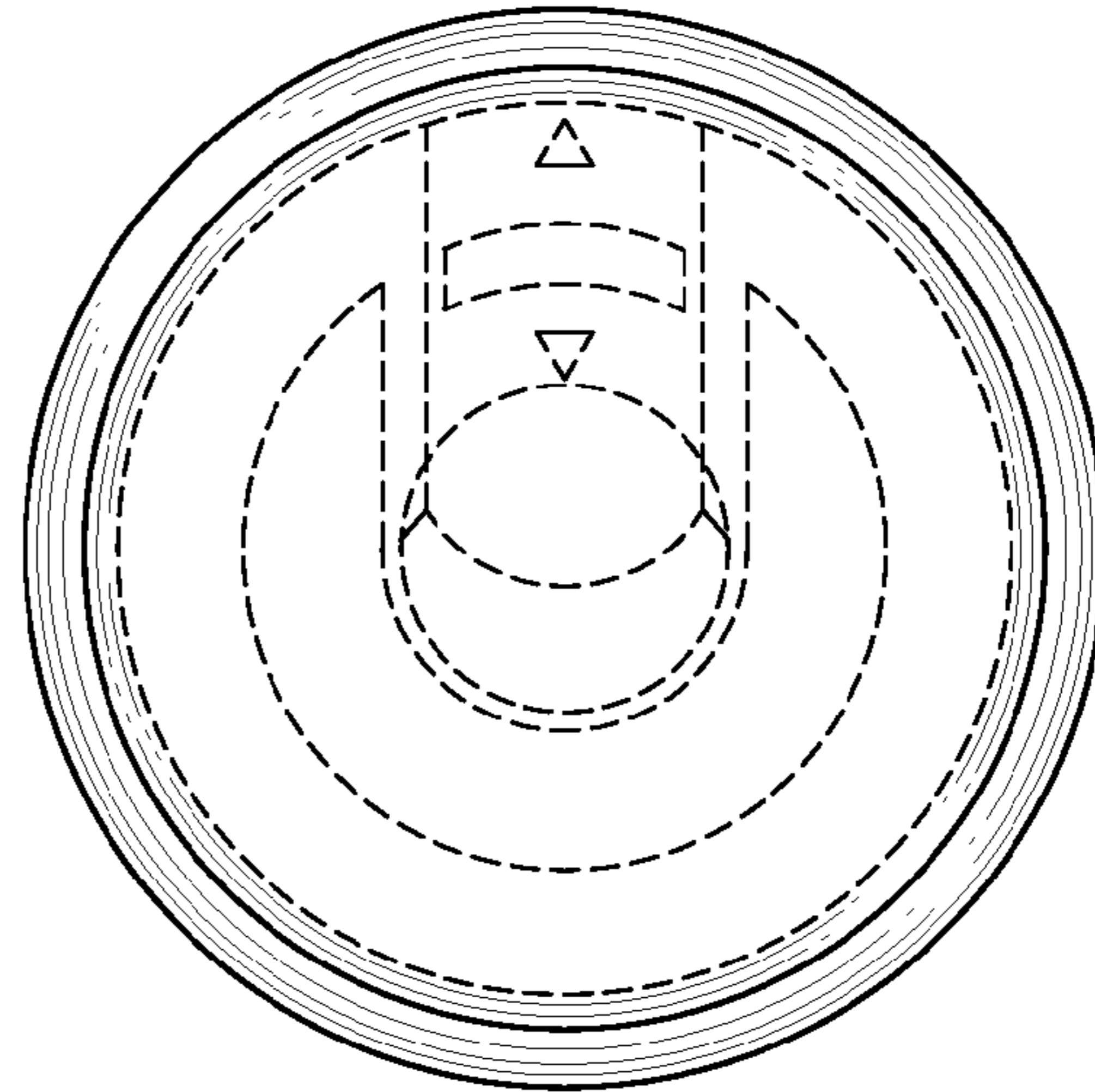

FIG. 3

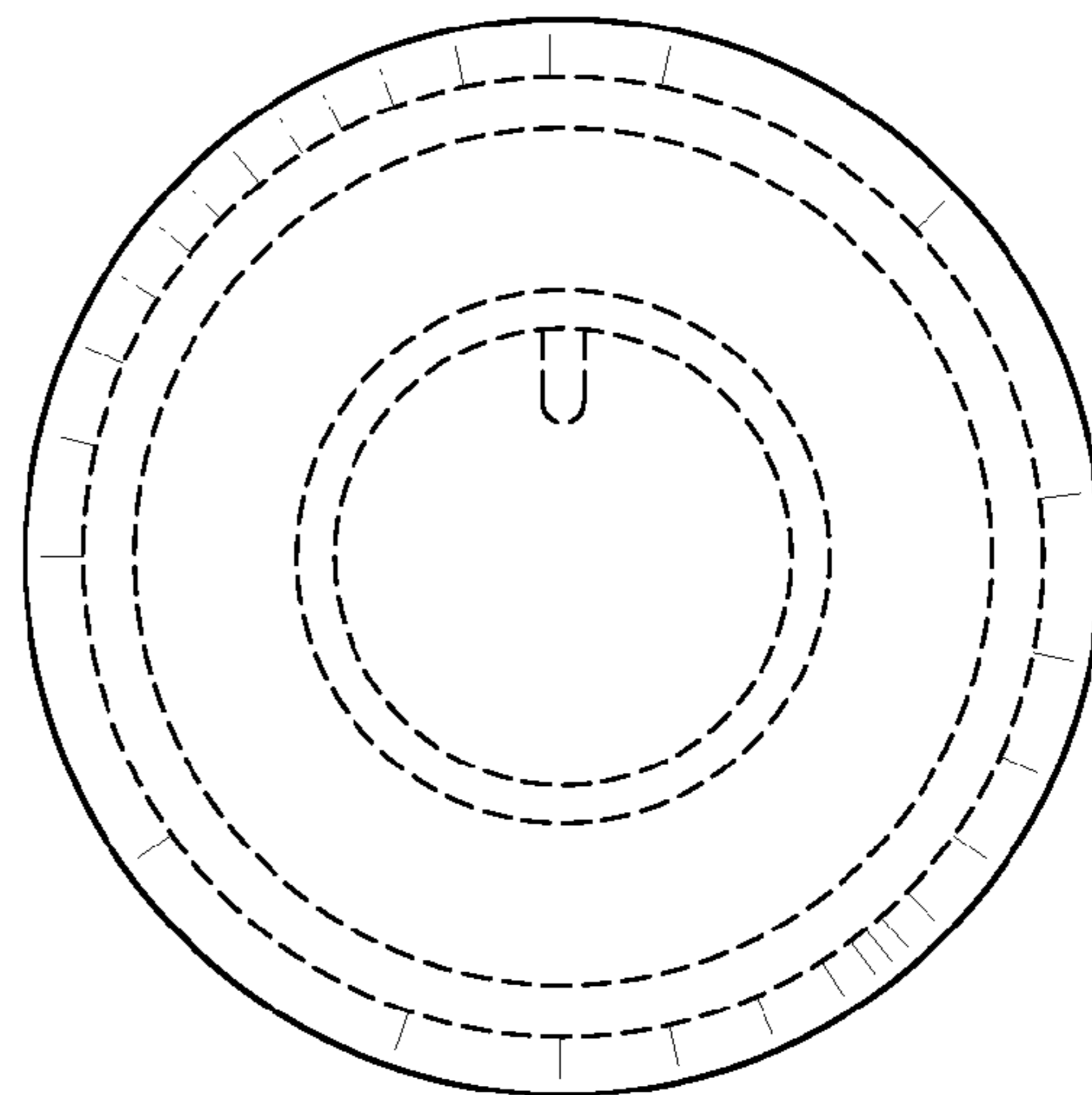

FIG. 4

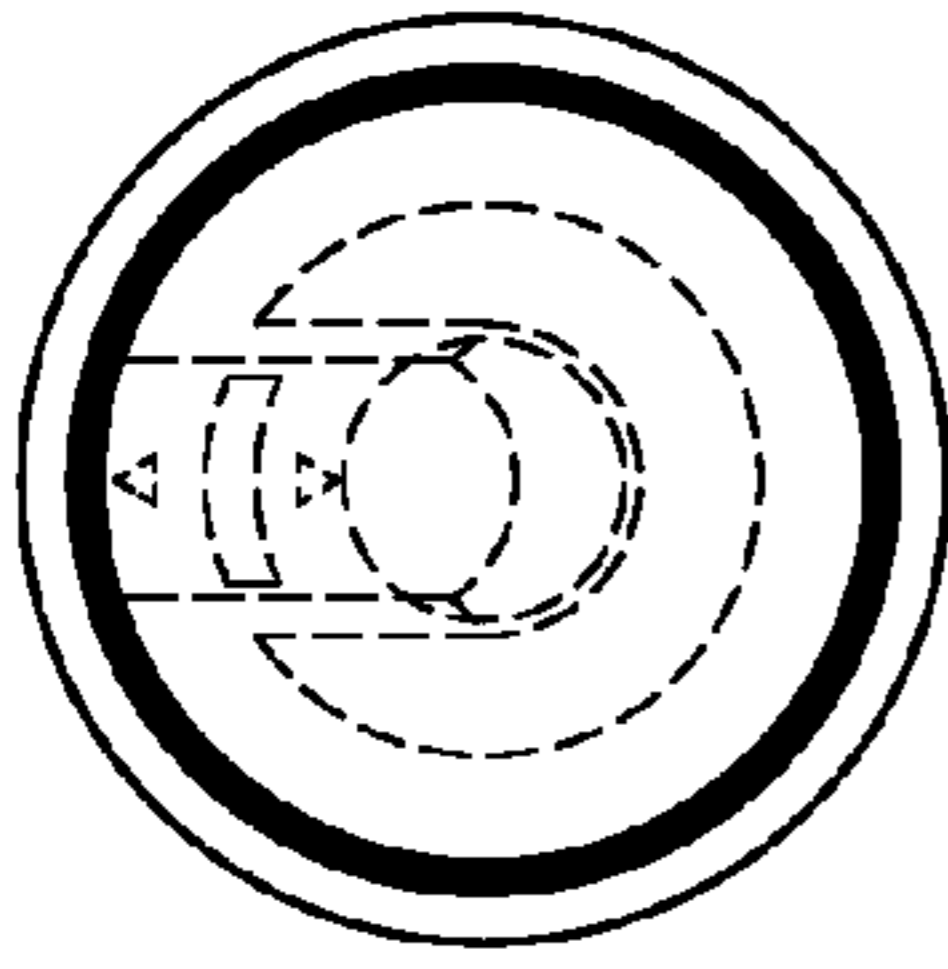

FIG. 11

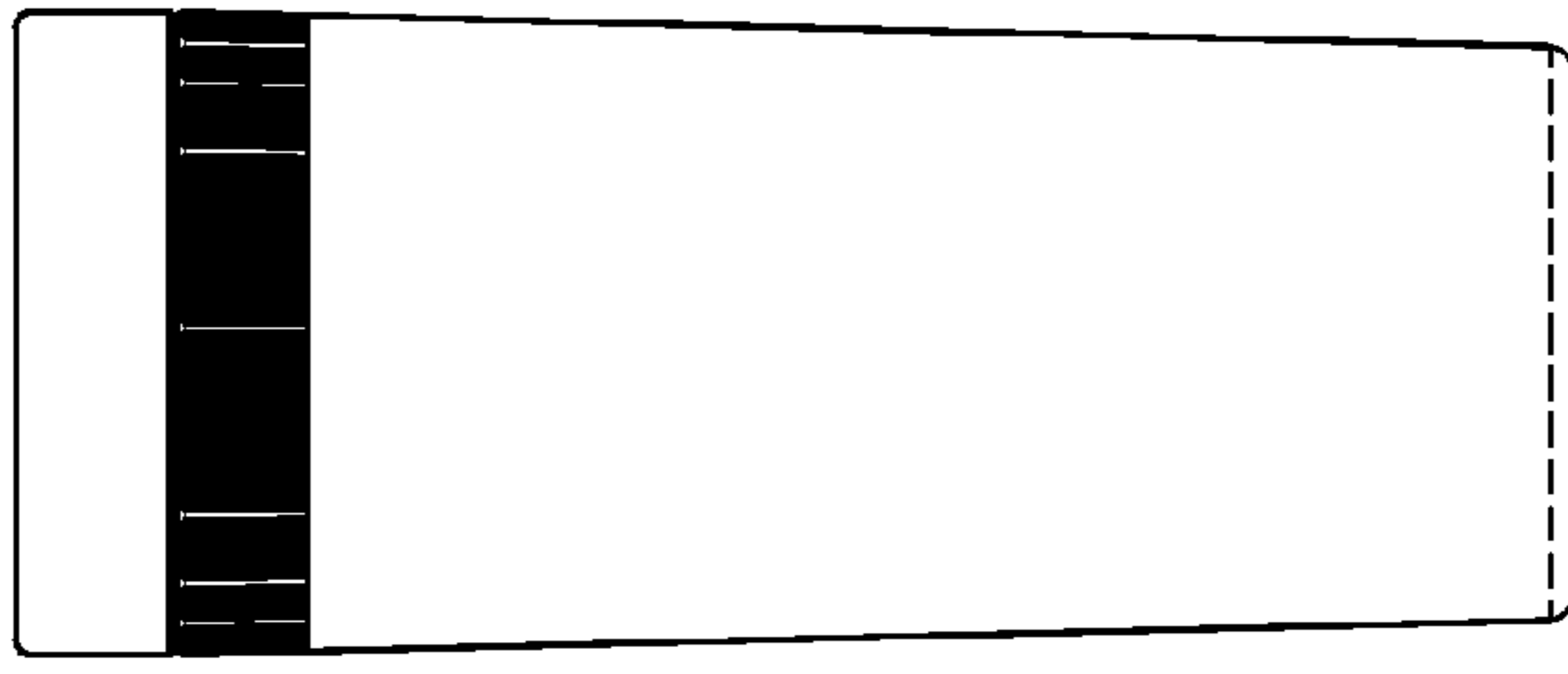

FIG. 10

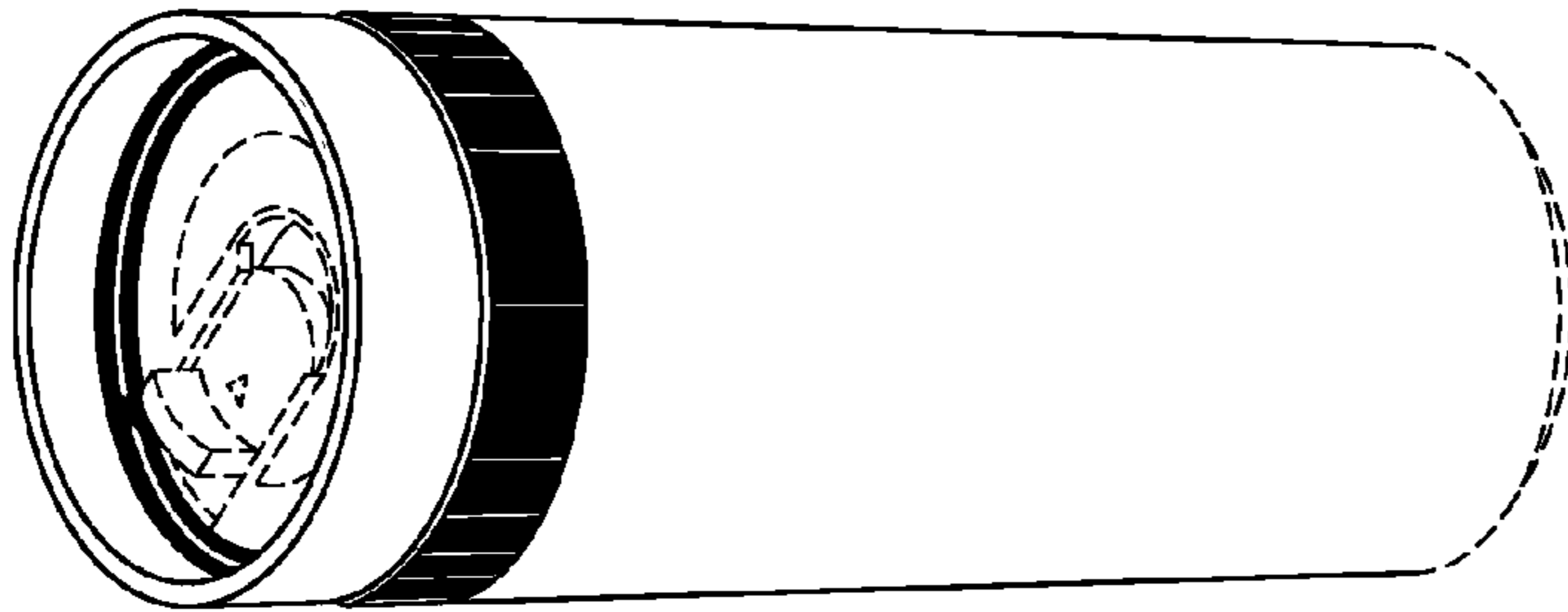

FIG. 9

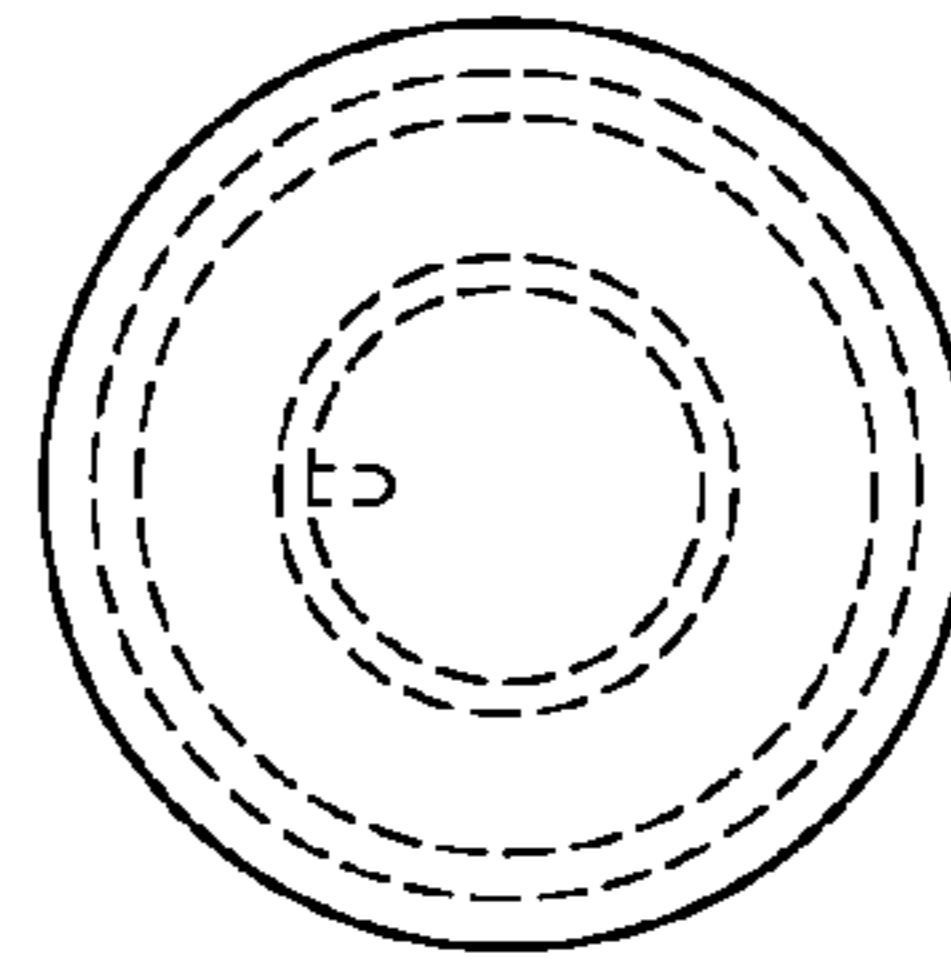

FIG. 12

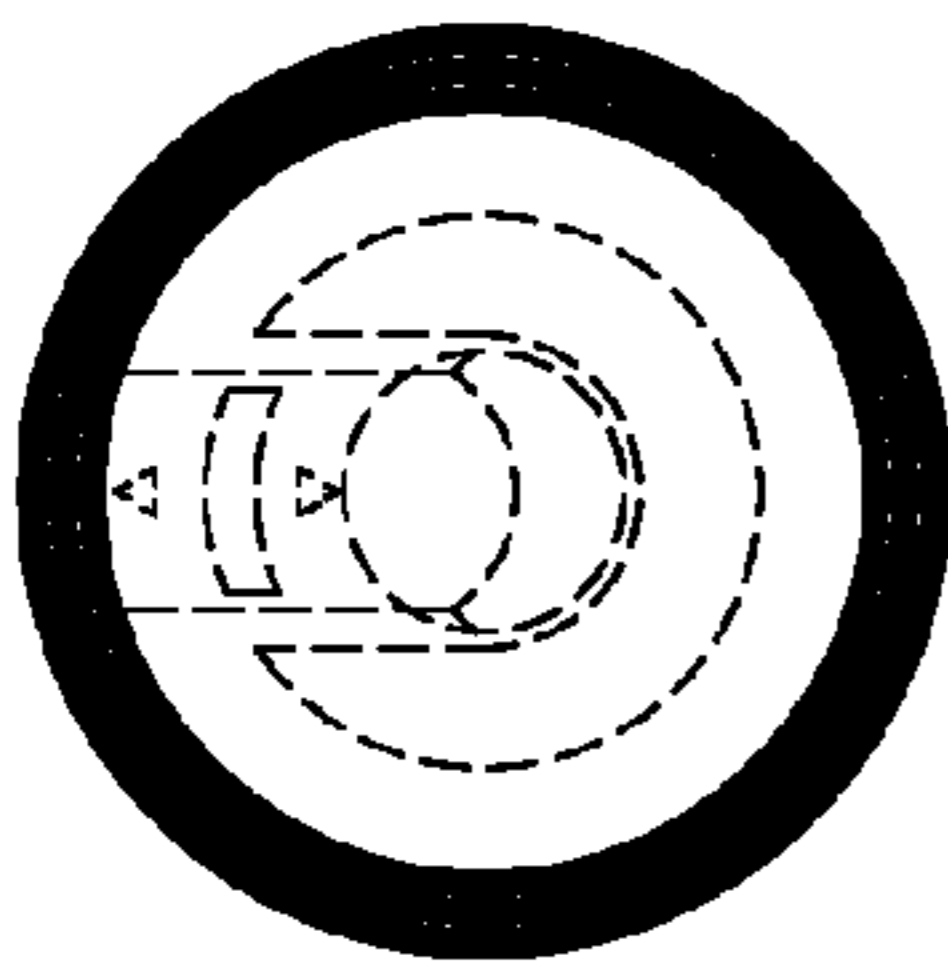

FIG. 7

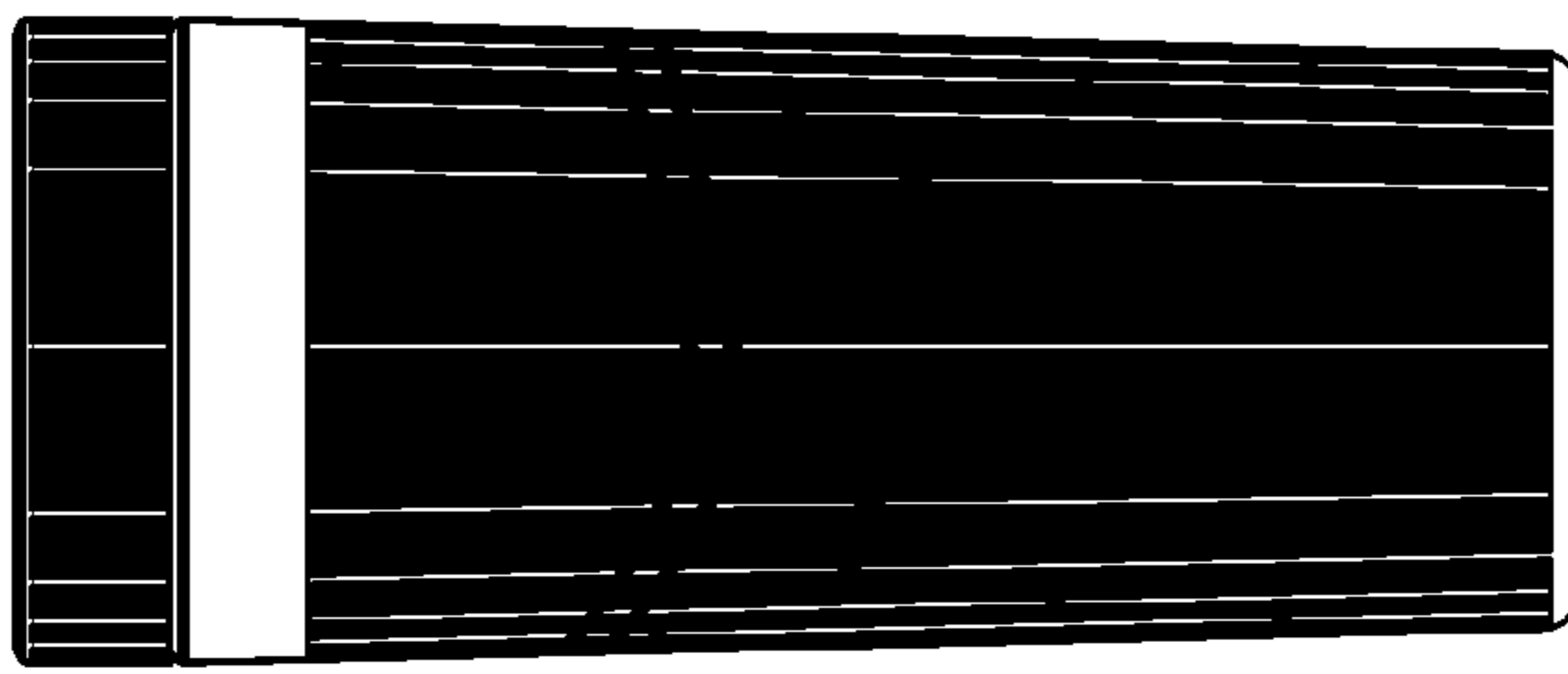

FIG. 6

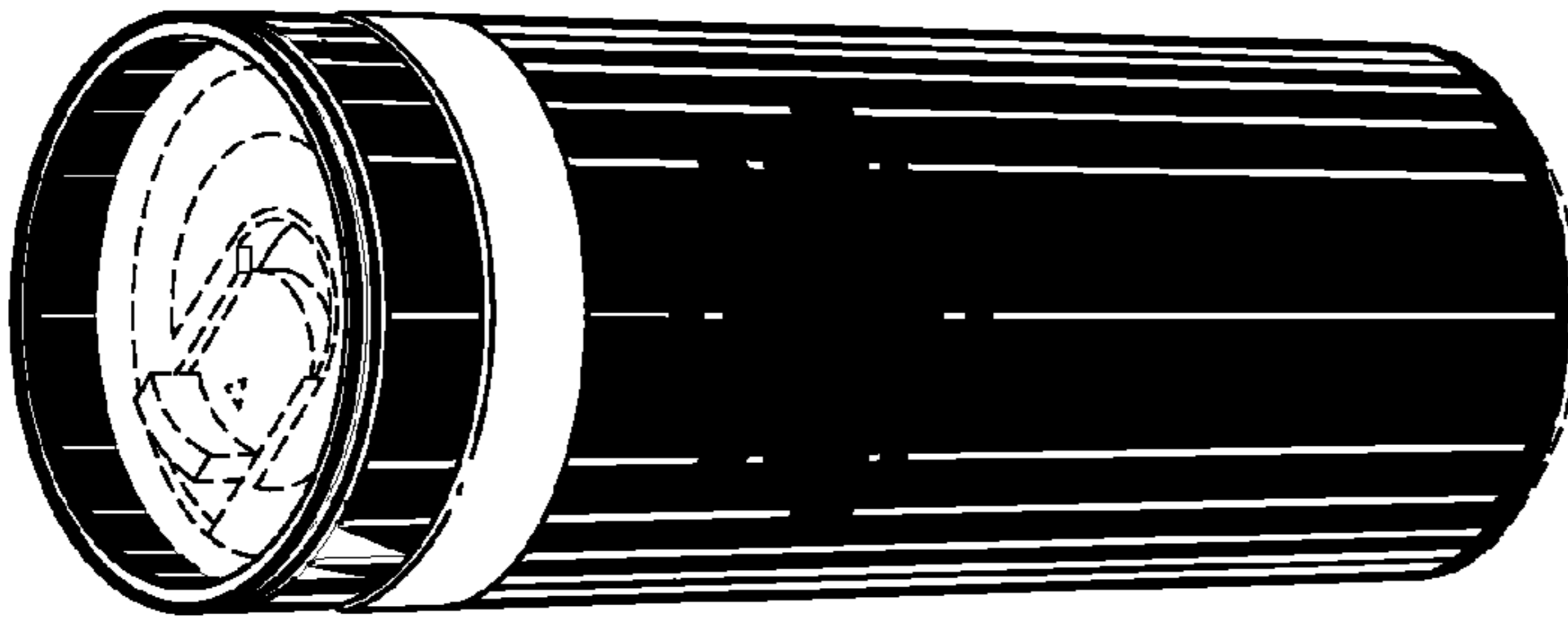

FIG. 5

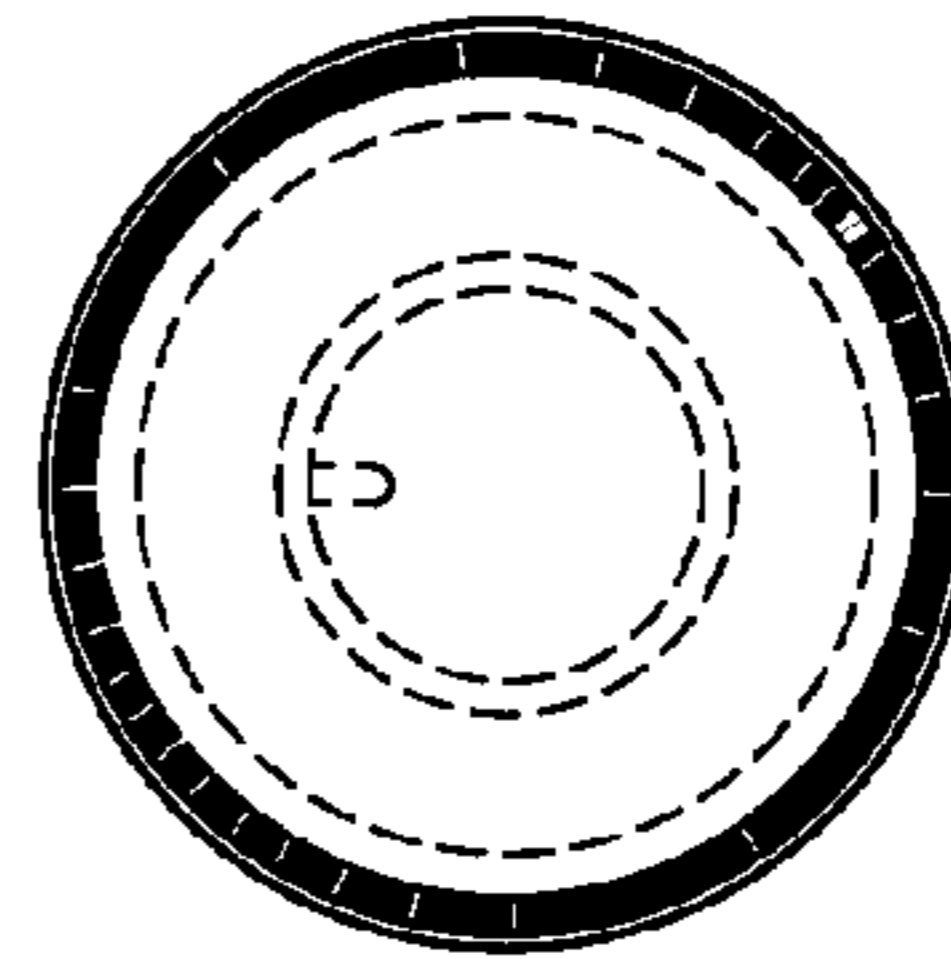

FIG. 8

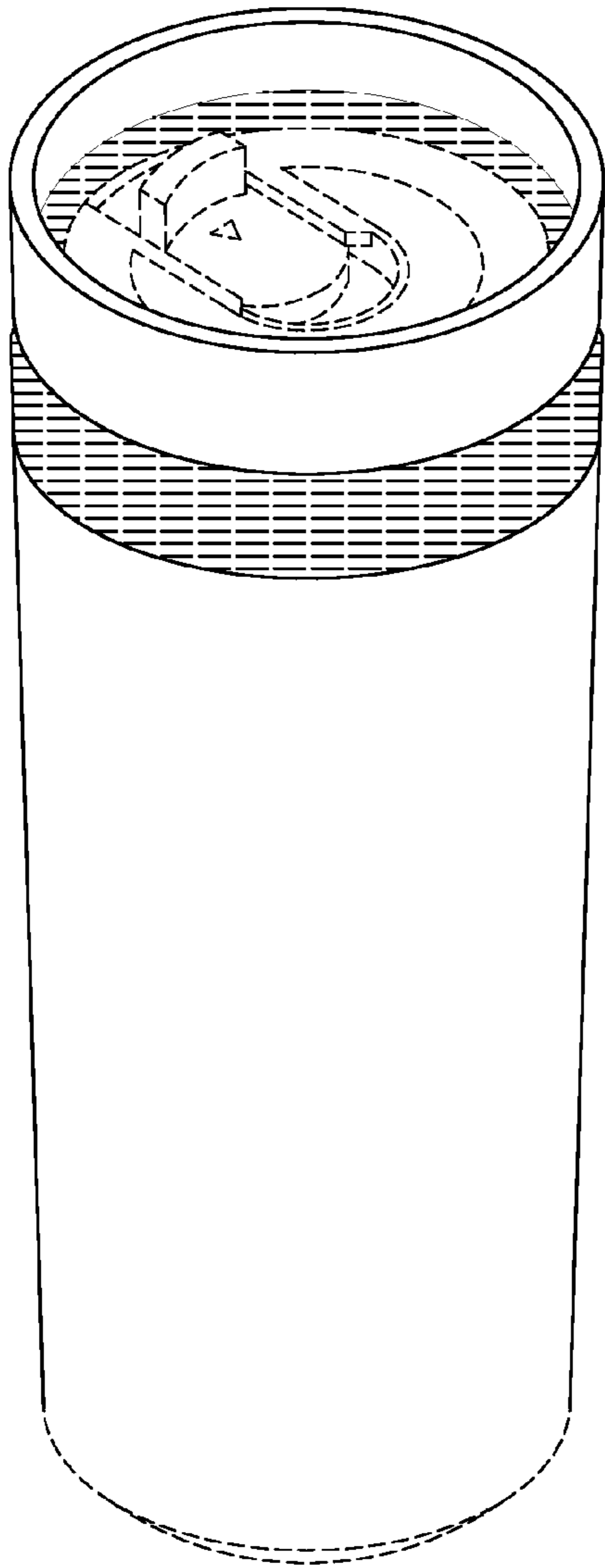

FIG. 13

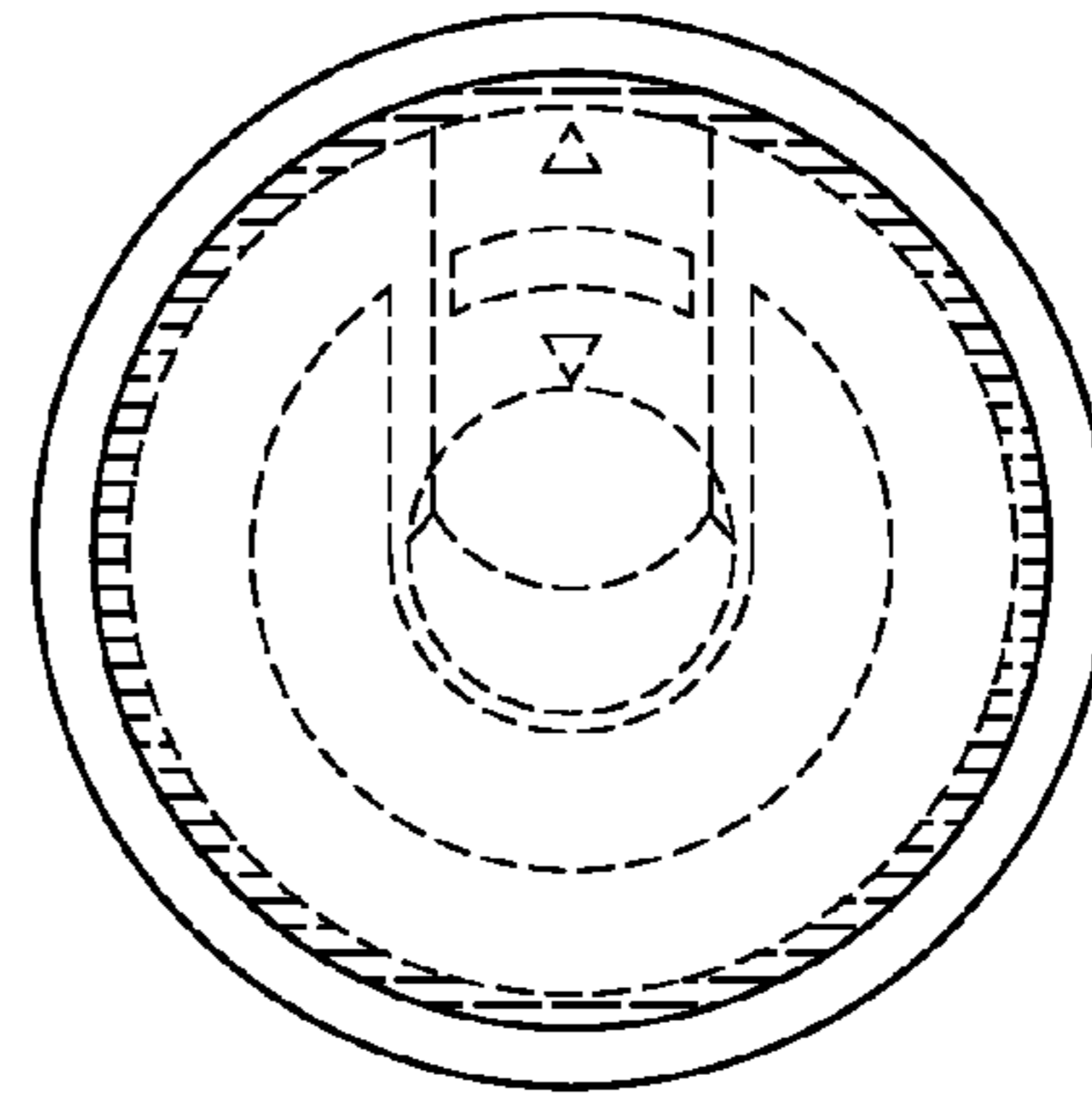

FIG. 15

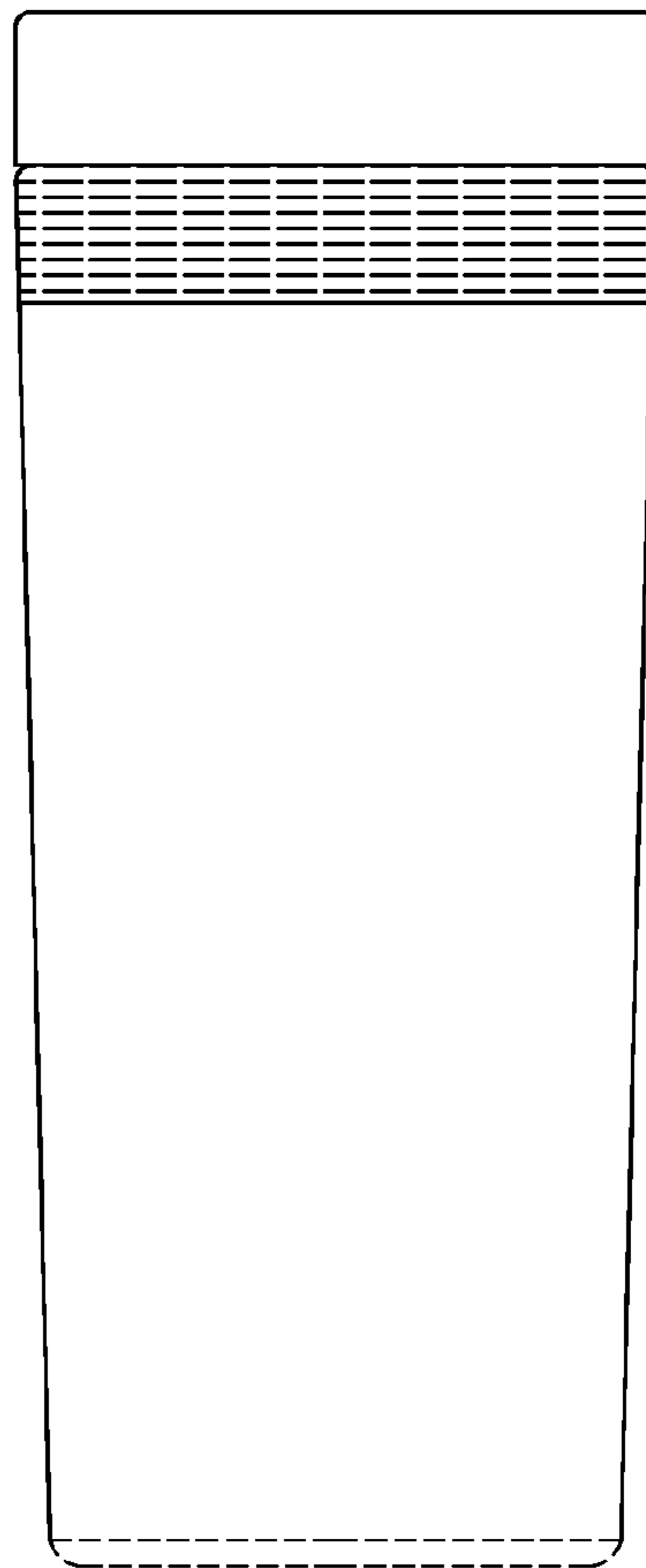

FIG. 14

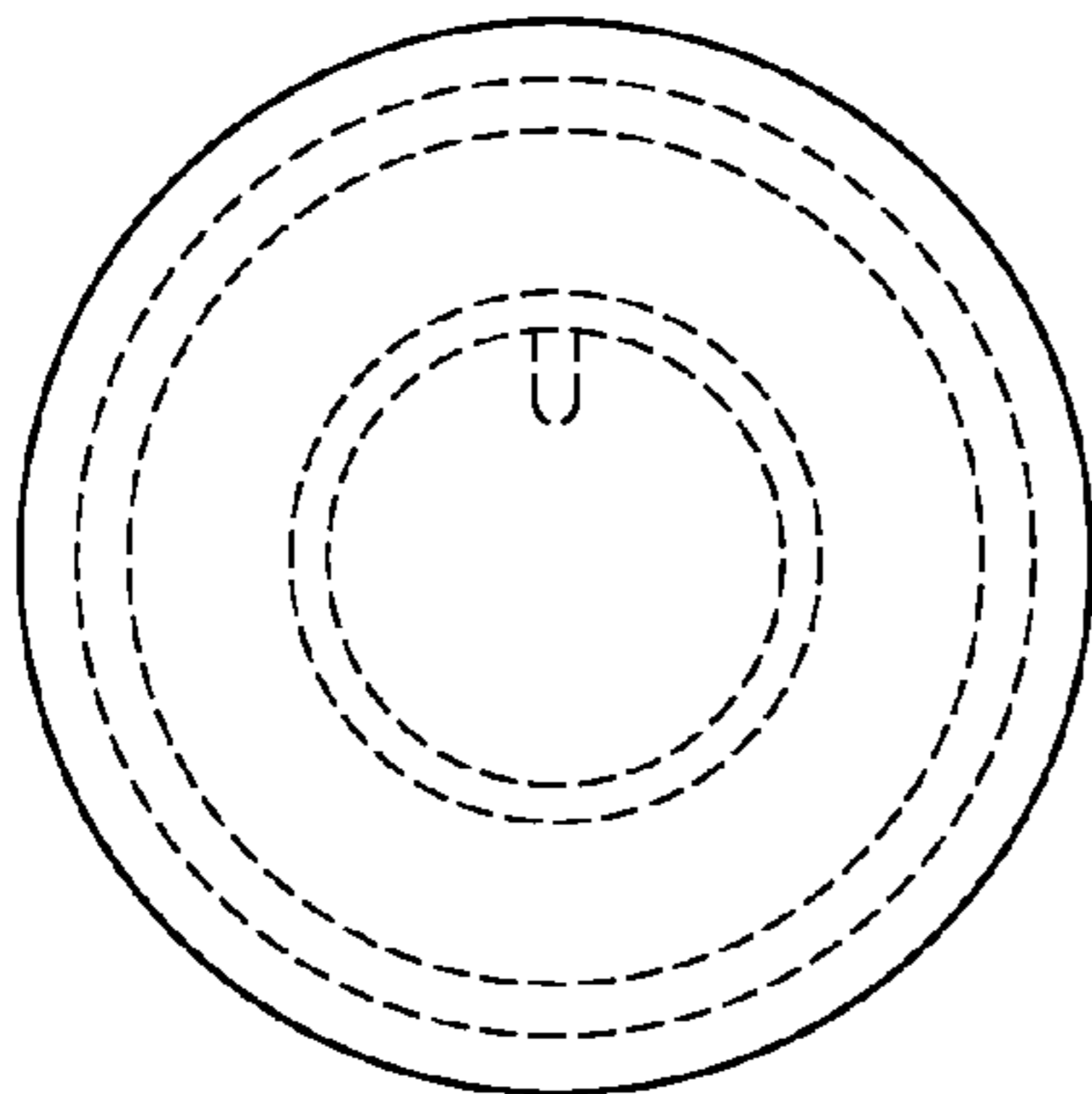

FIG. 16



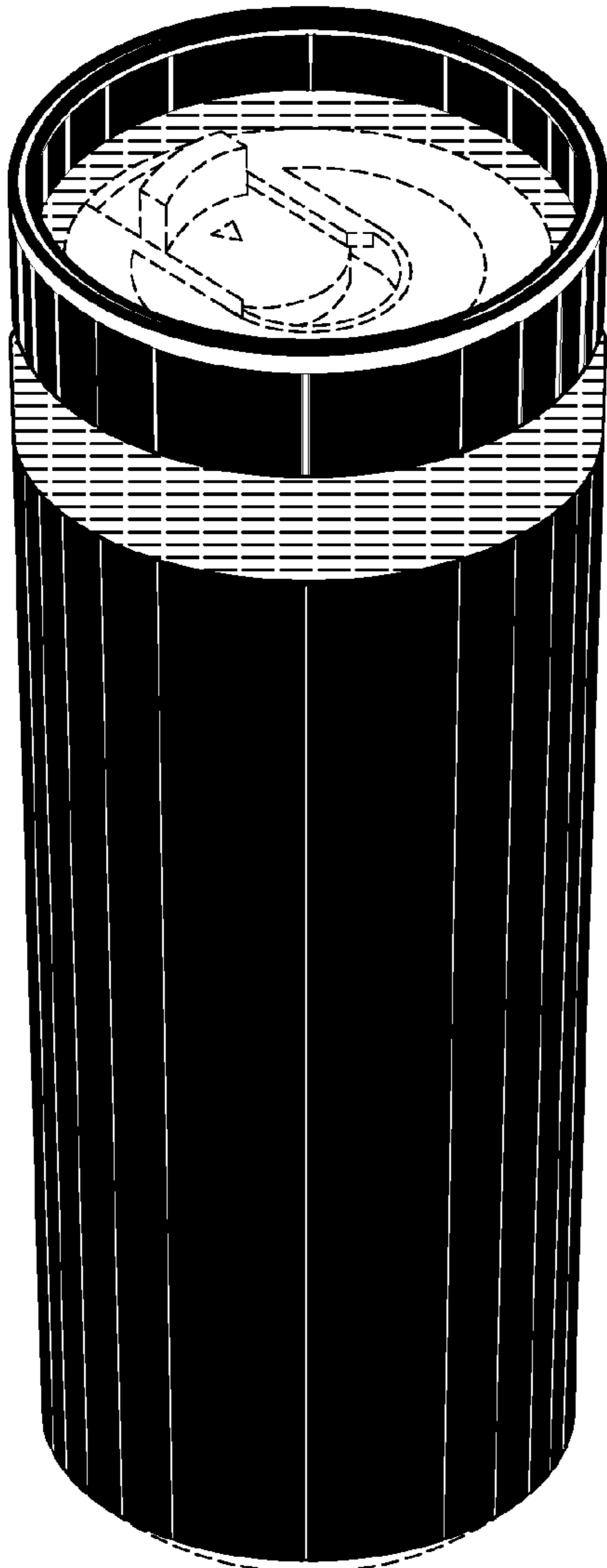

FIG. 17

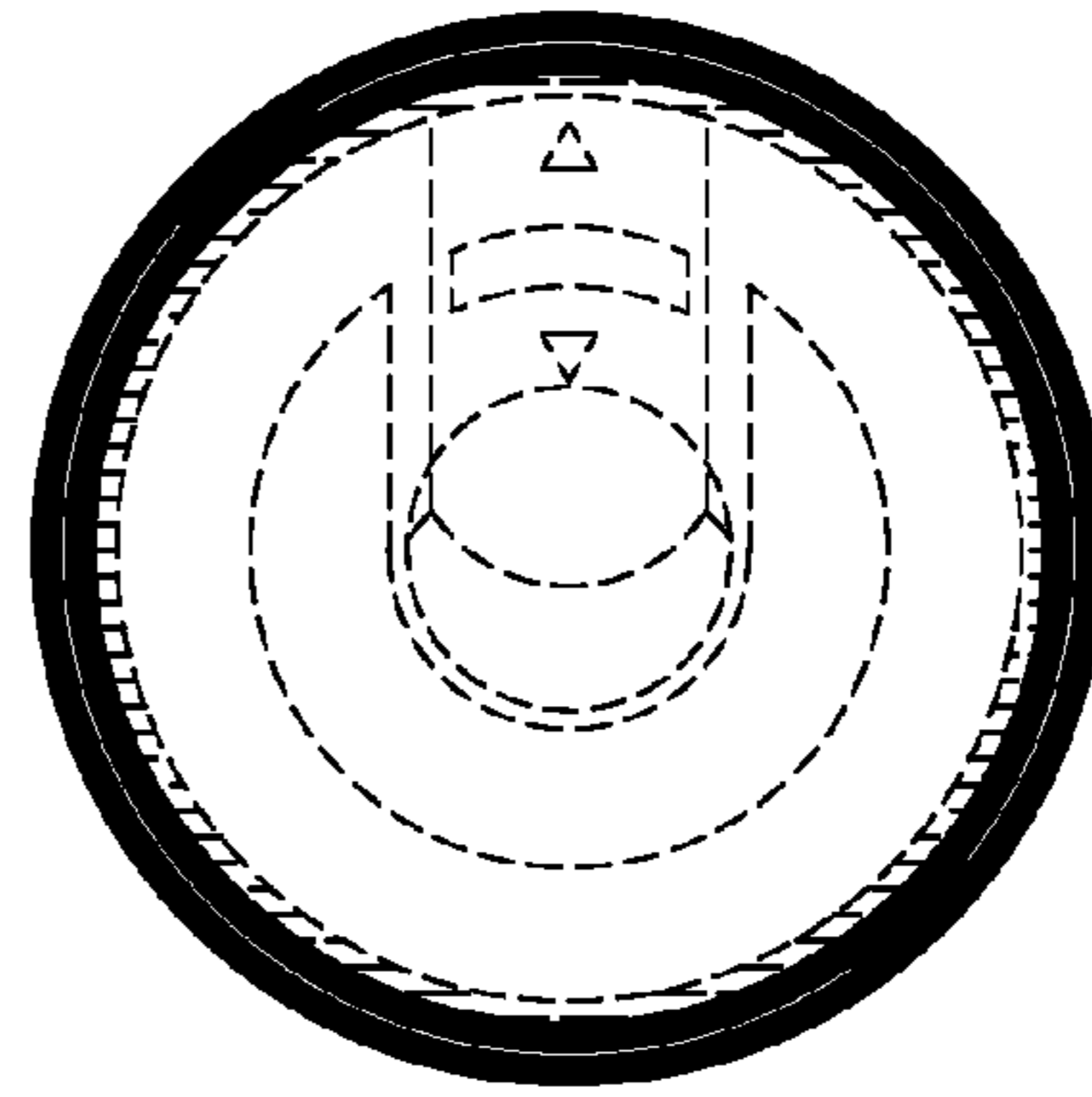

FIG. 19

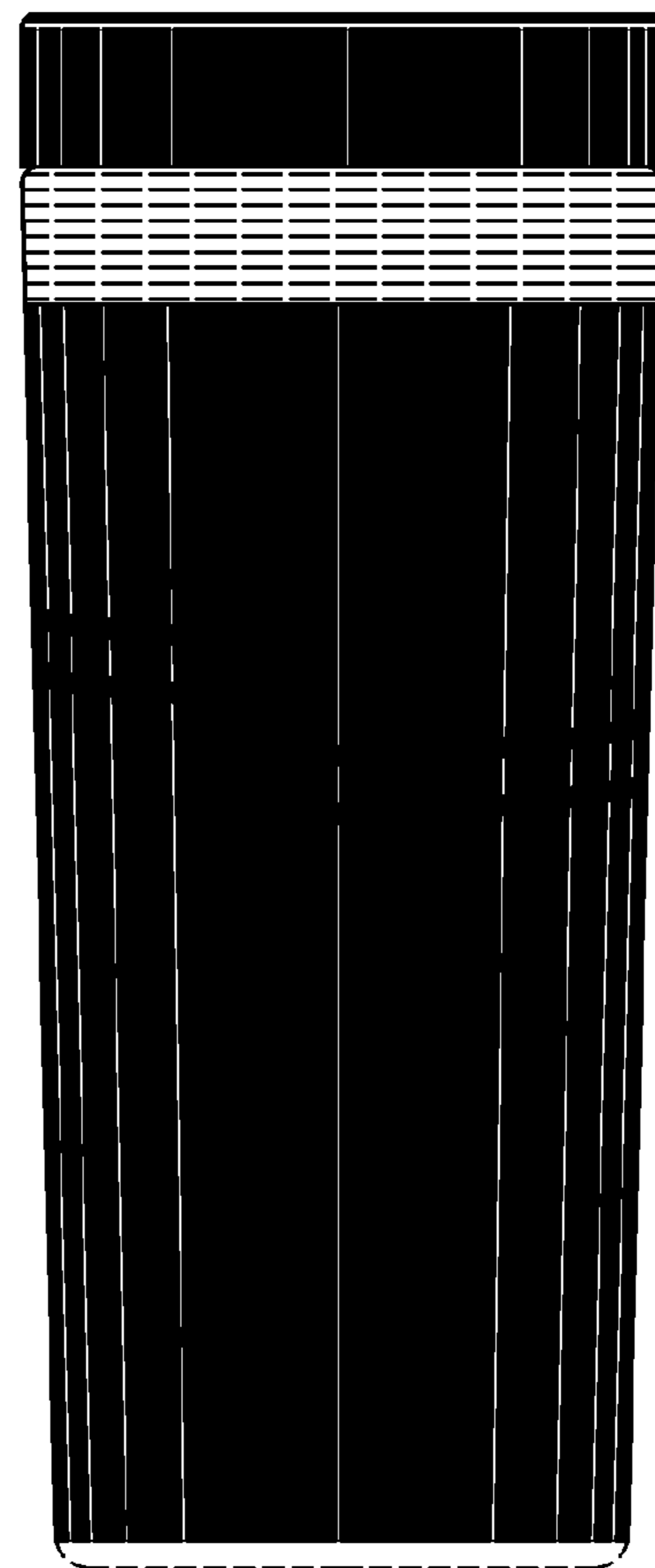

FIG. 18

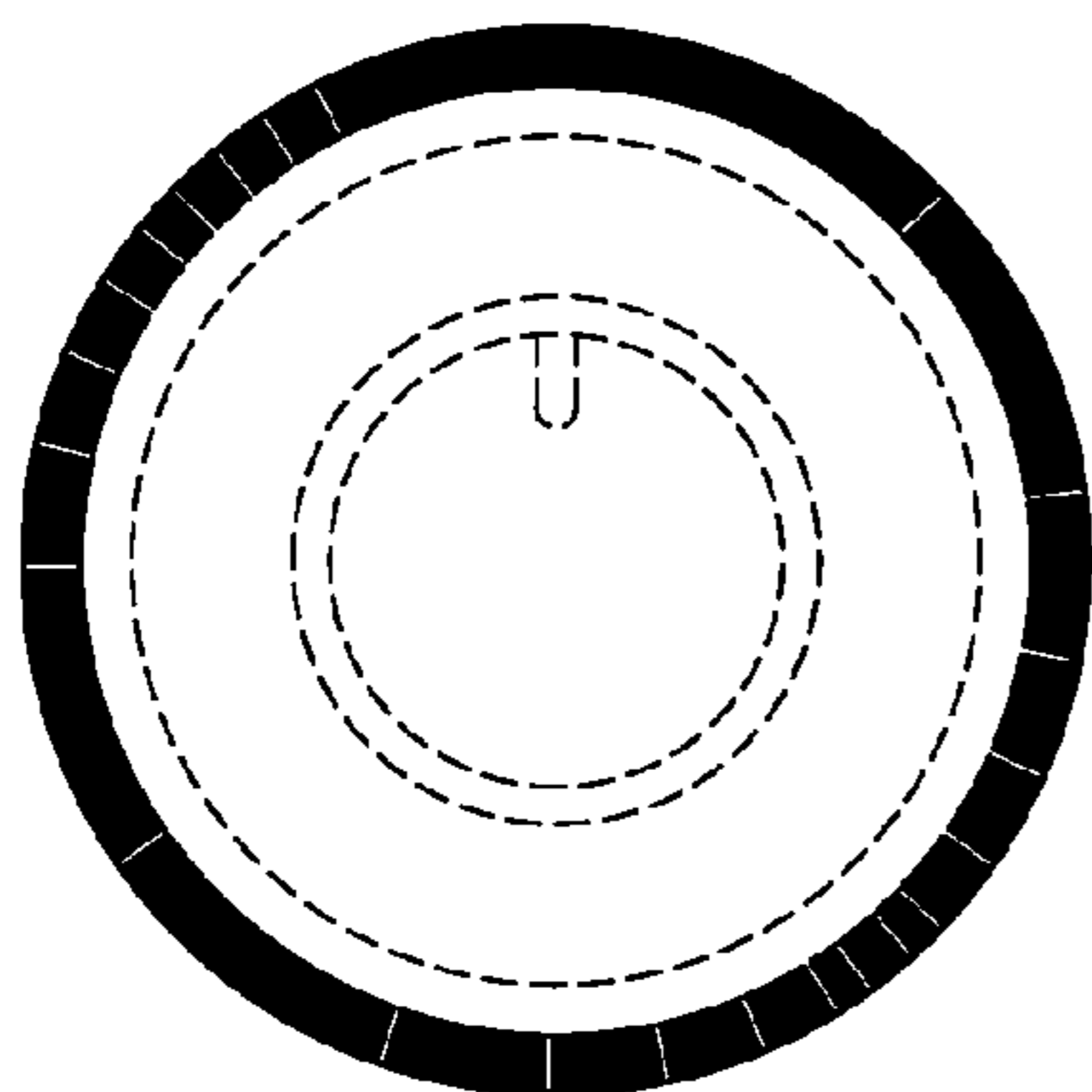

FIG. 20



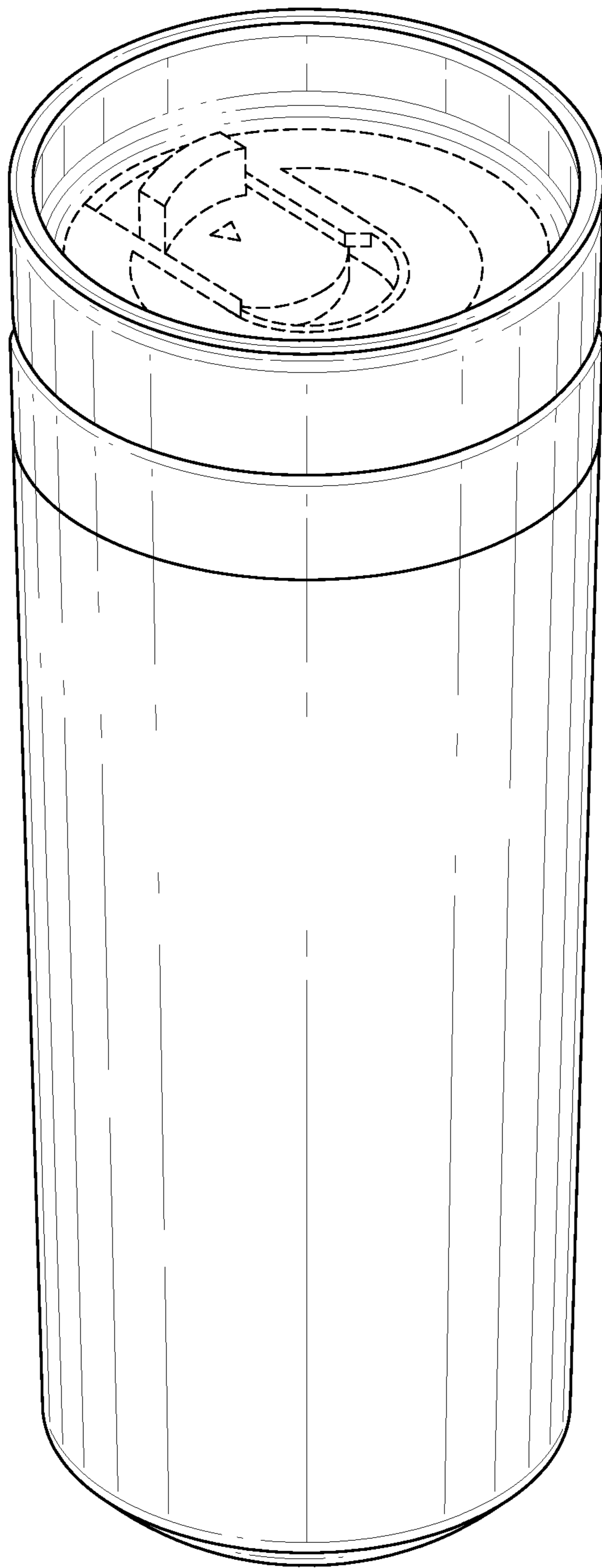

FIG.21

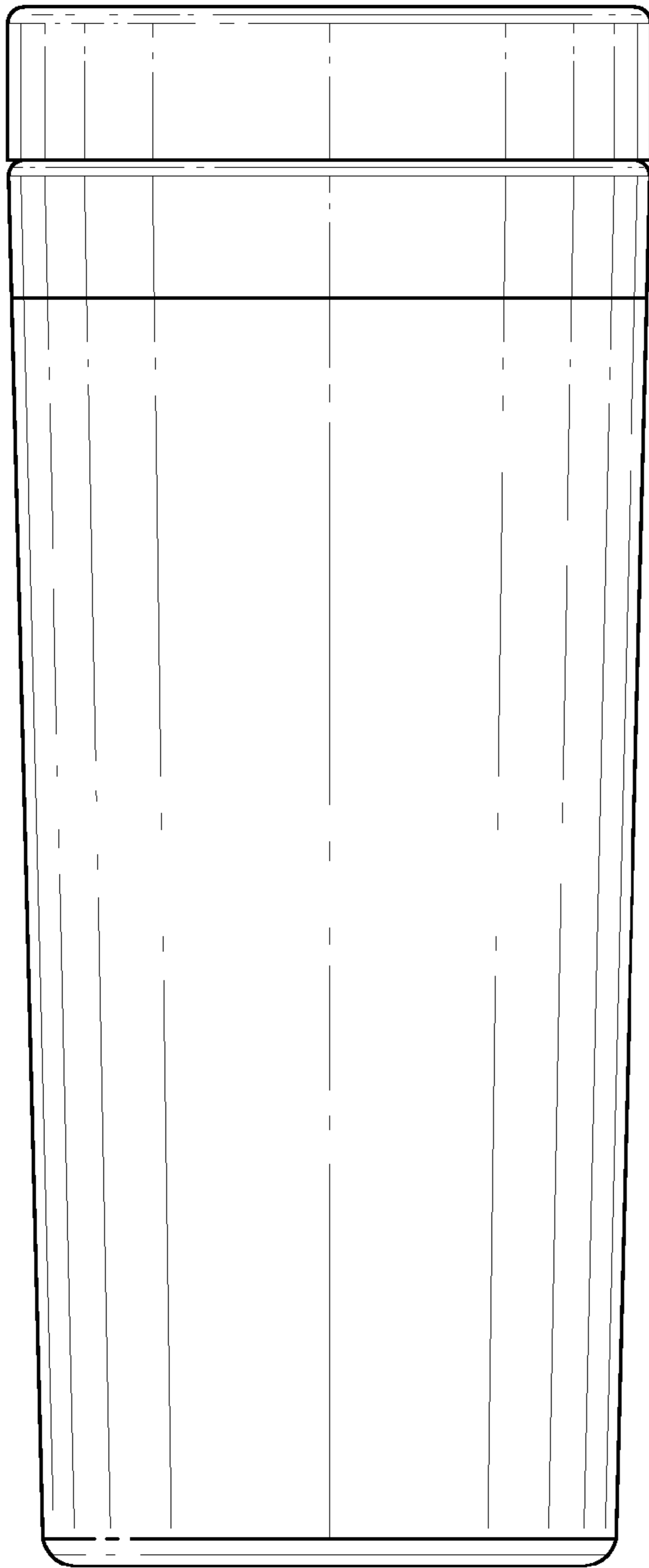

FIG. 22

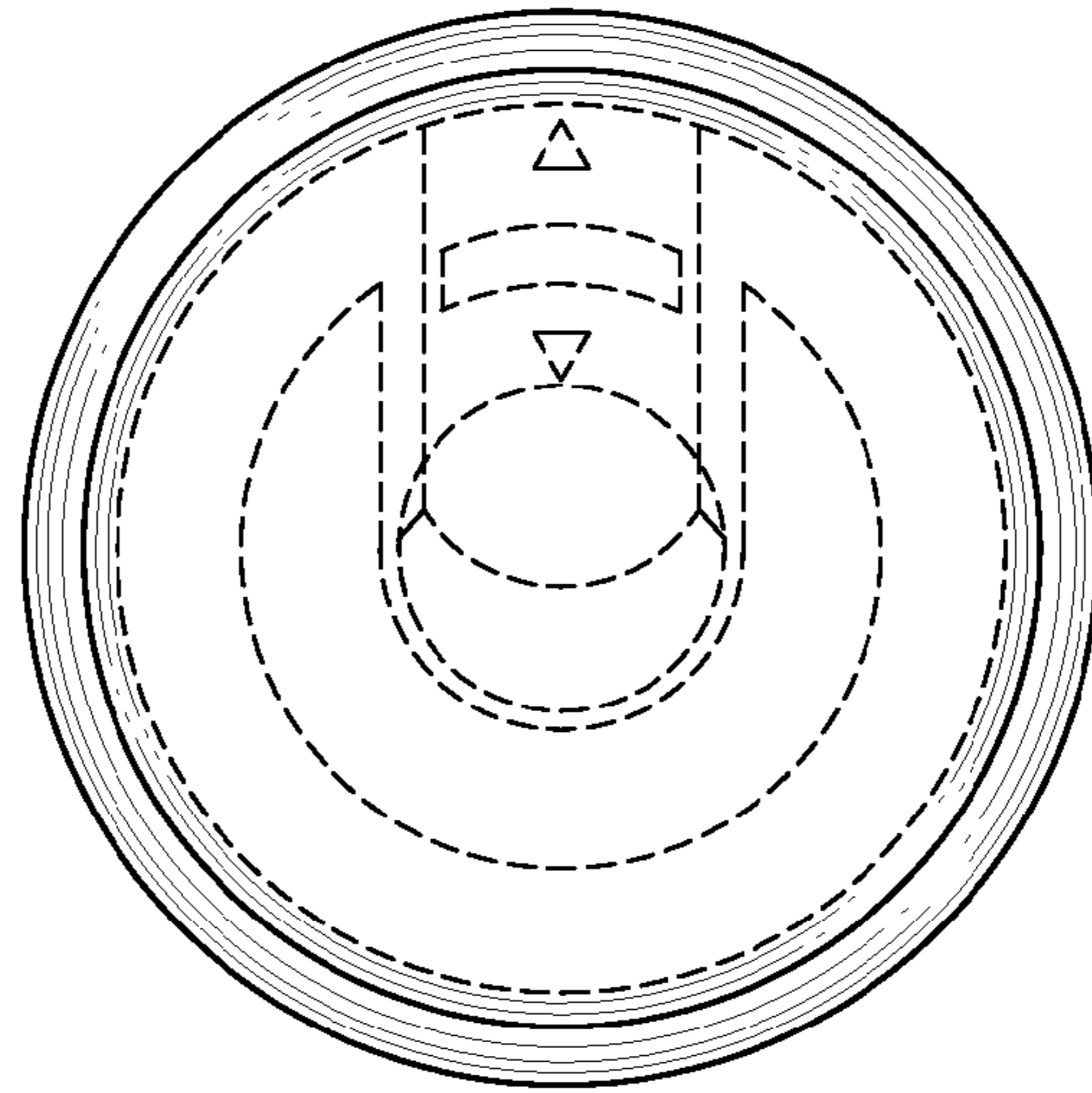

FIG. 23

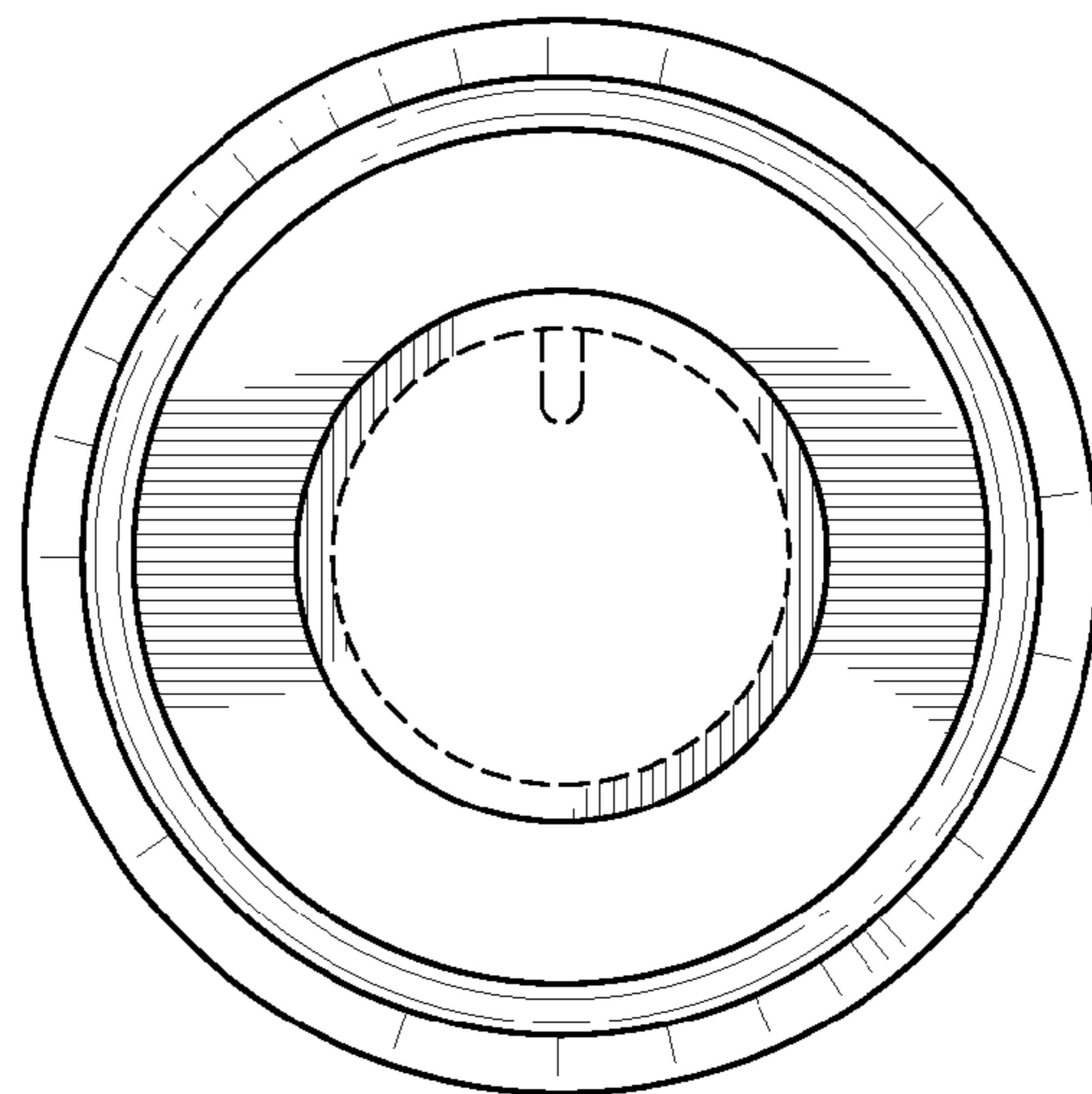

FIG. 24

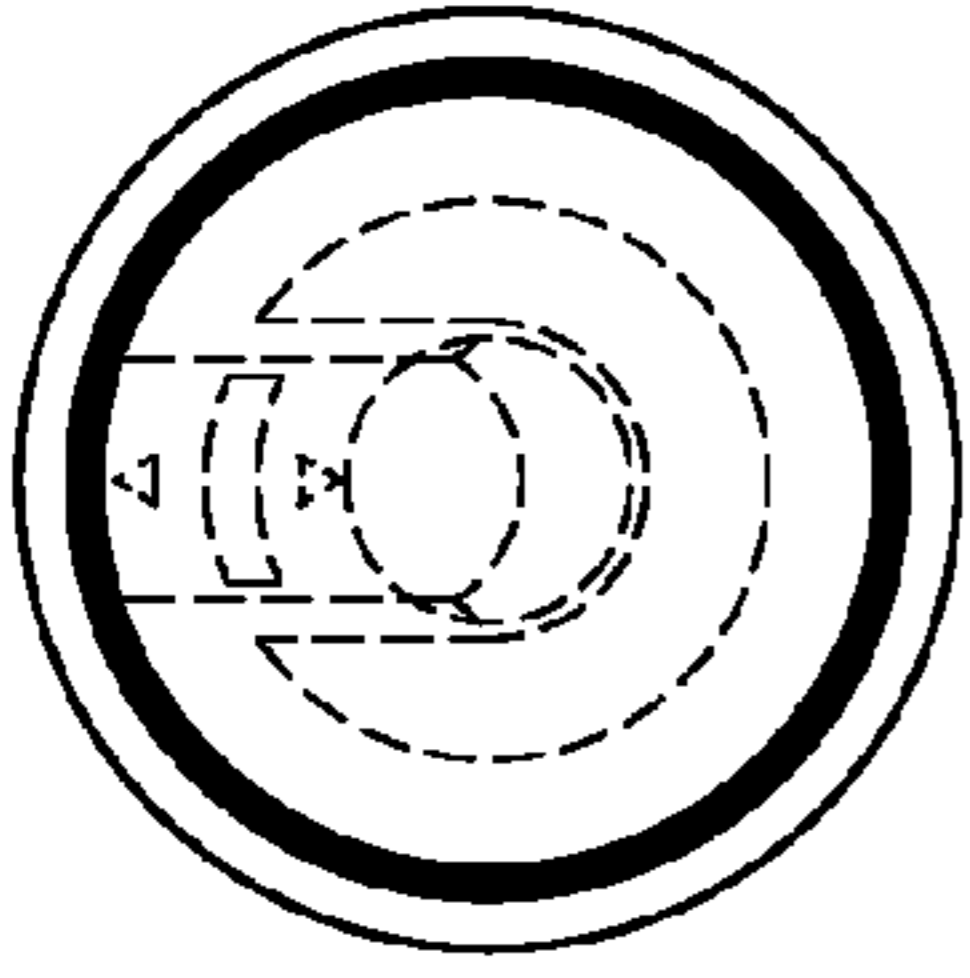

FIG. 31

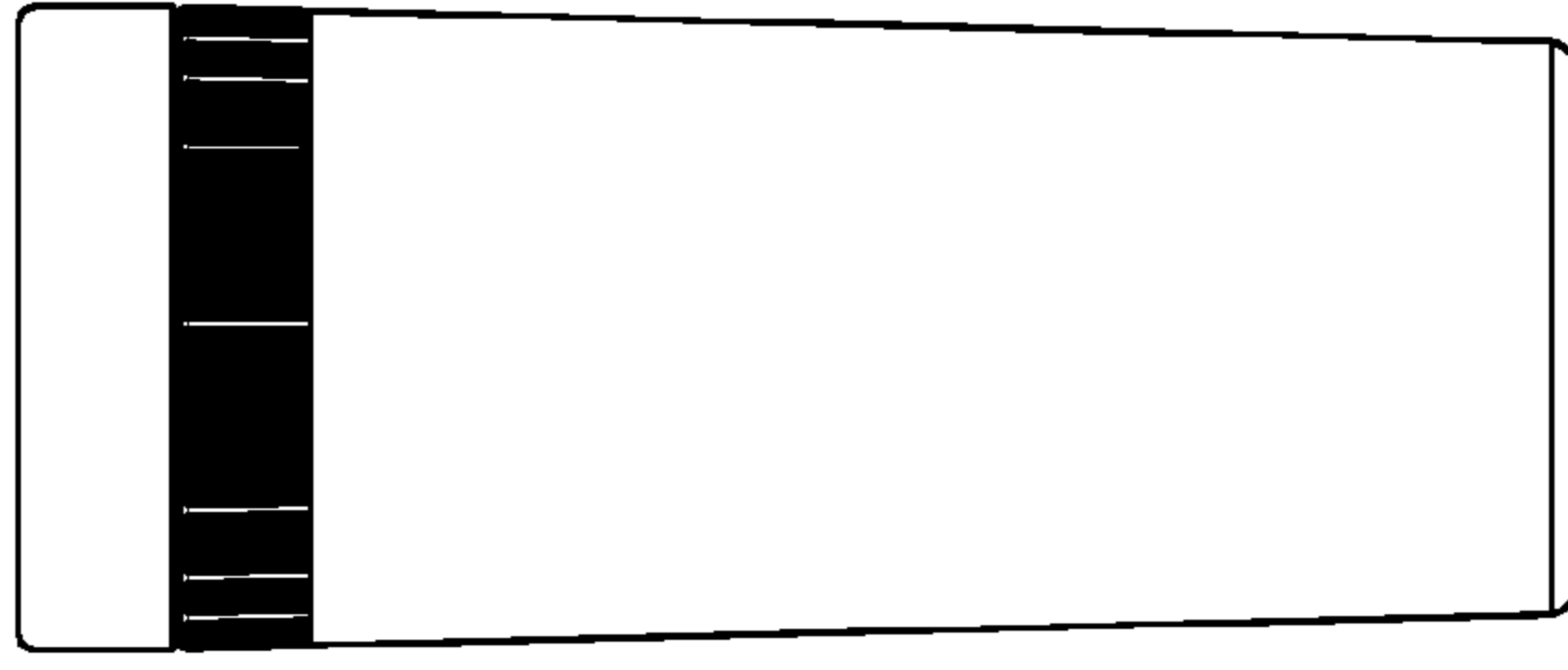

FIG. 30

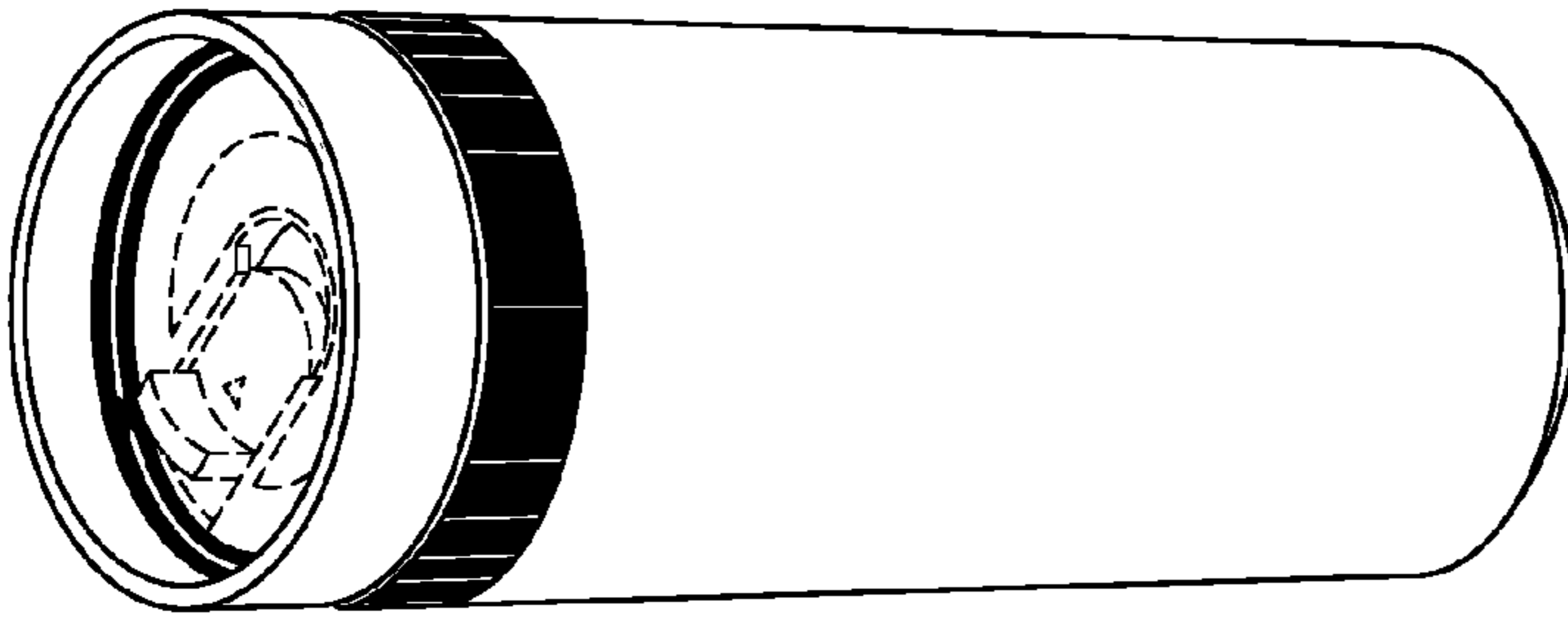

FIG. 29

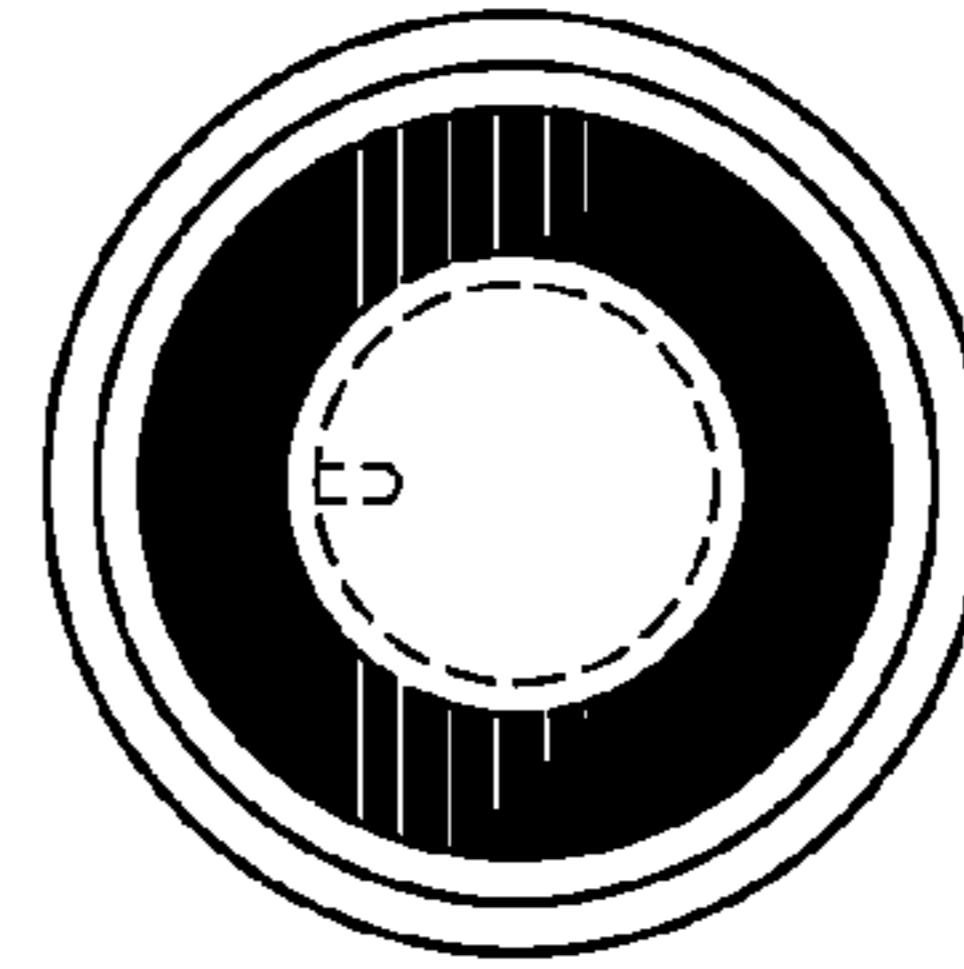

FIG. 32

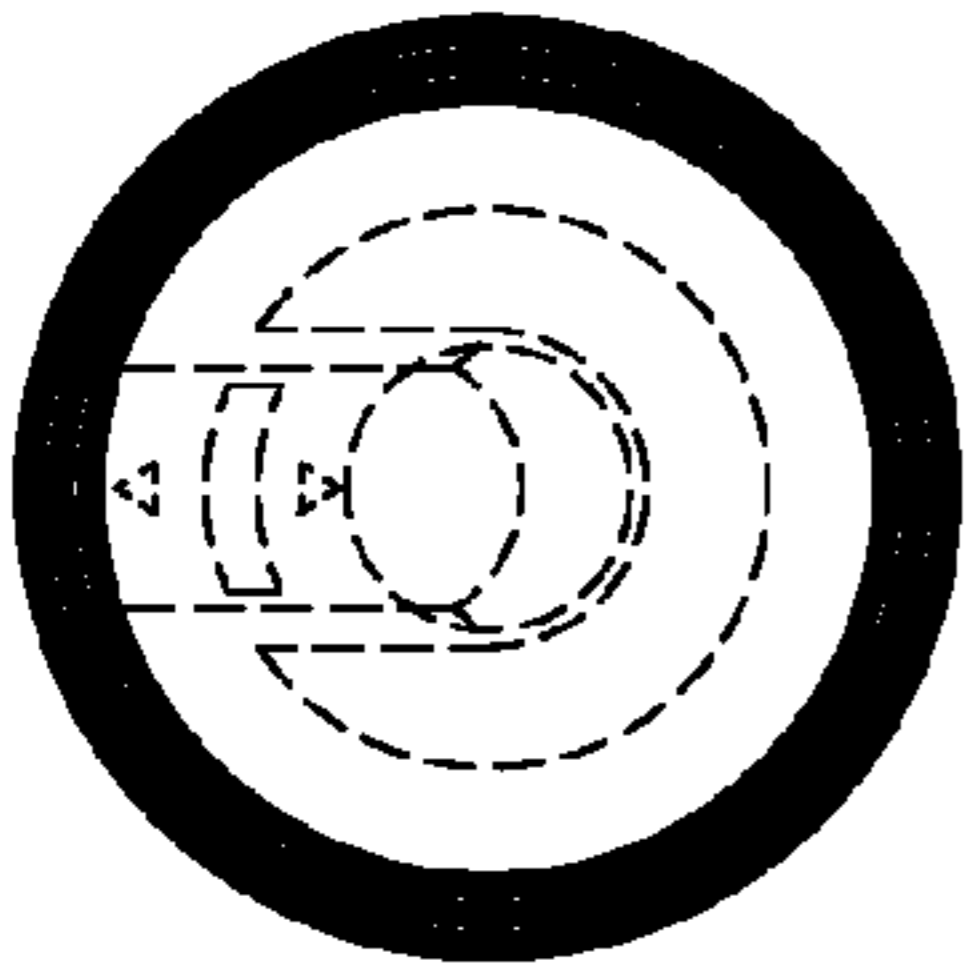

FIG. 27

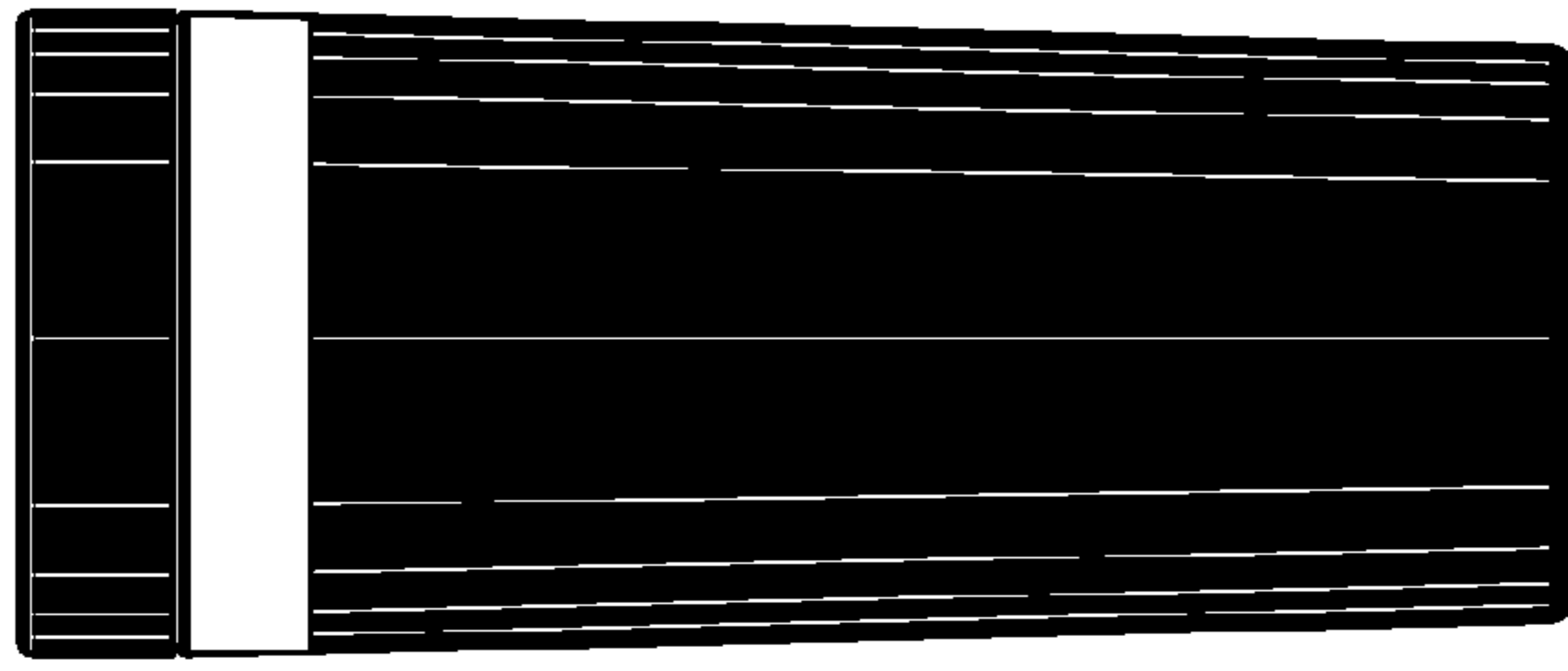

FIG. 26

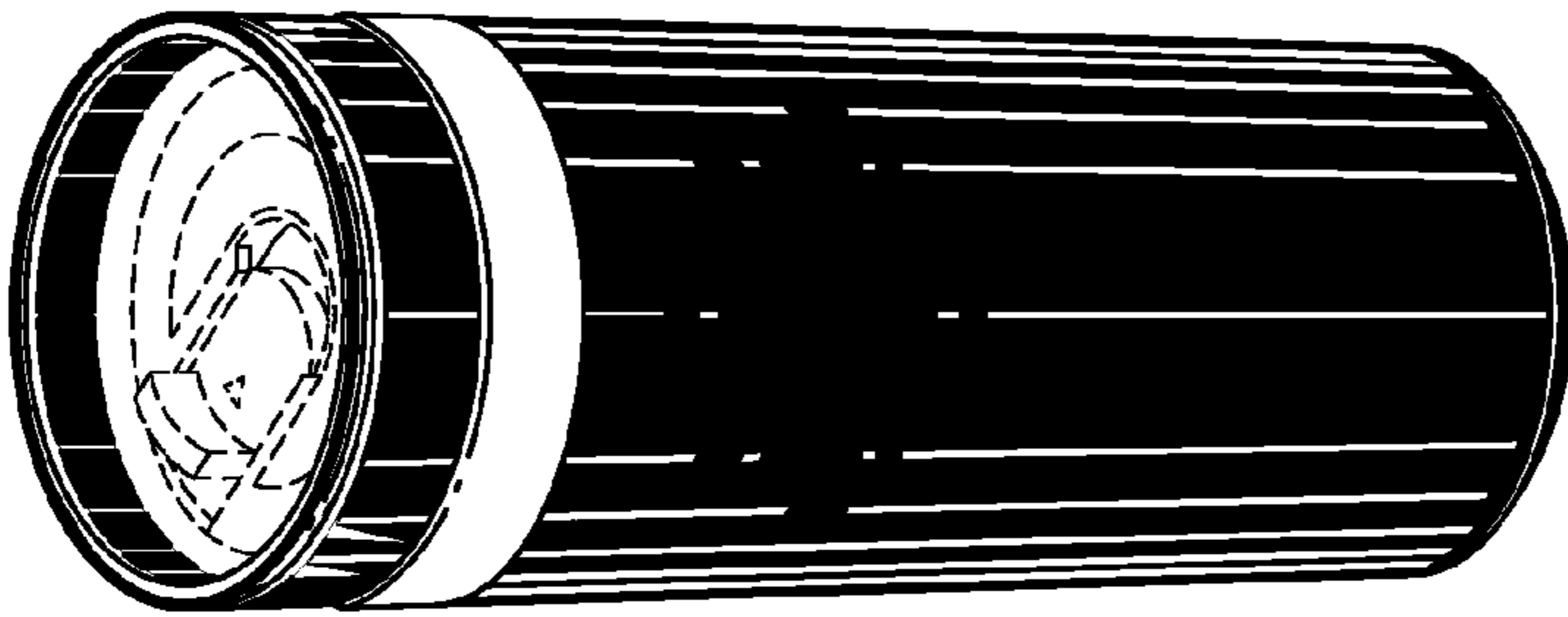

FIG. 25

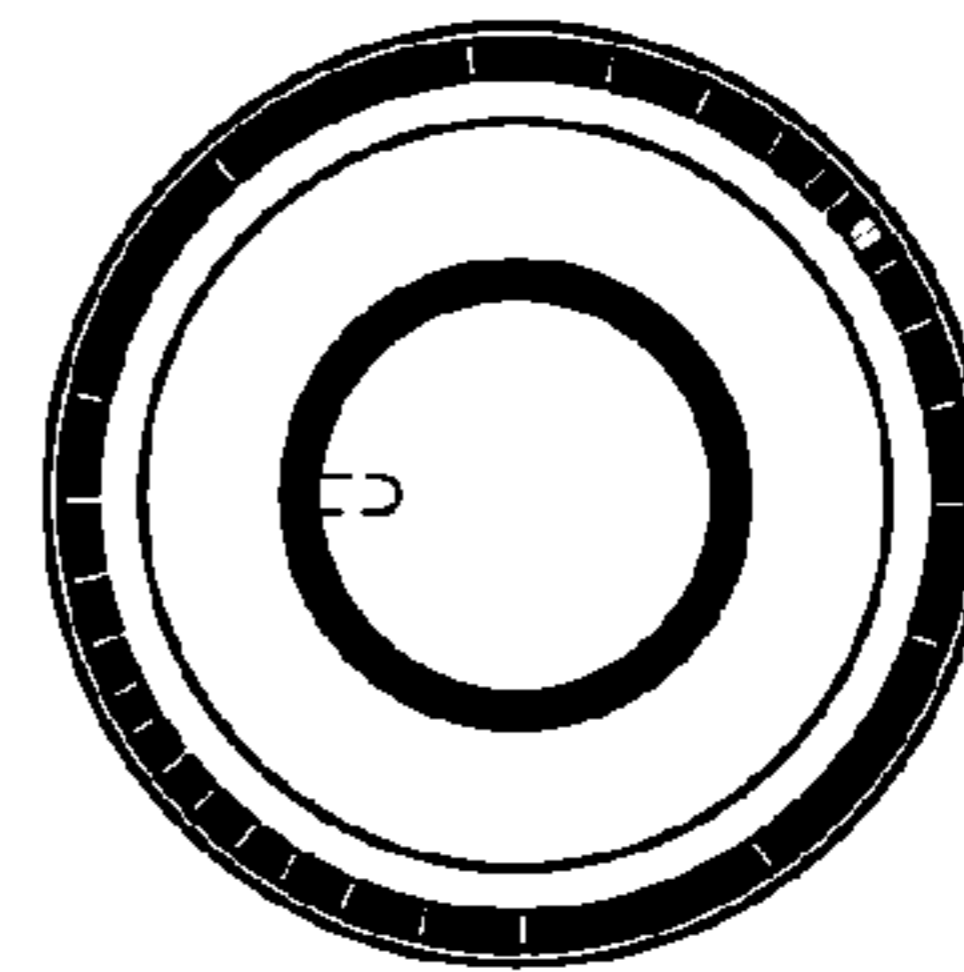

FIG. 28

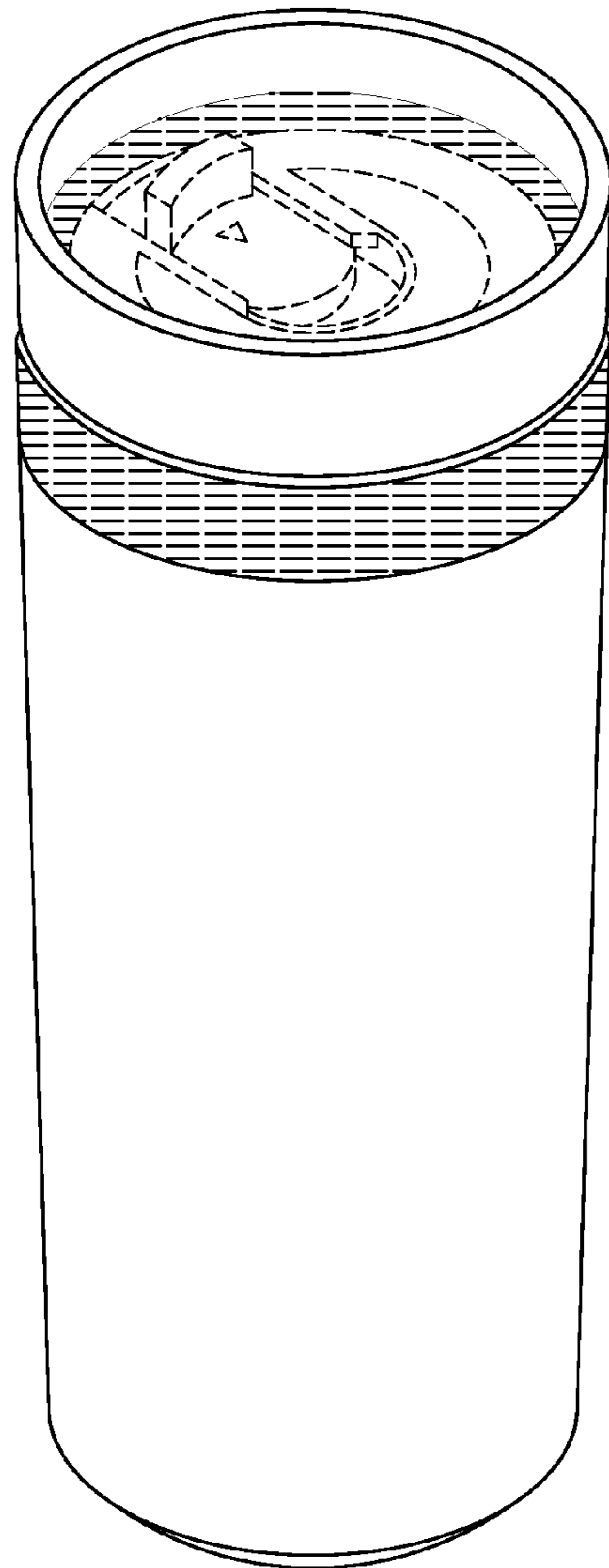

FIG. 33

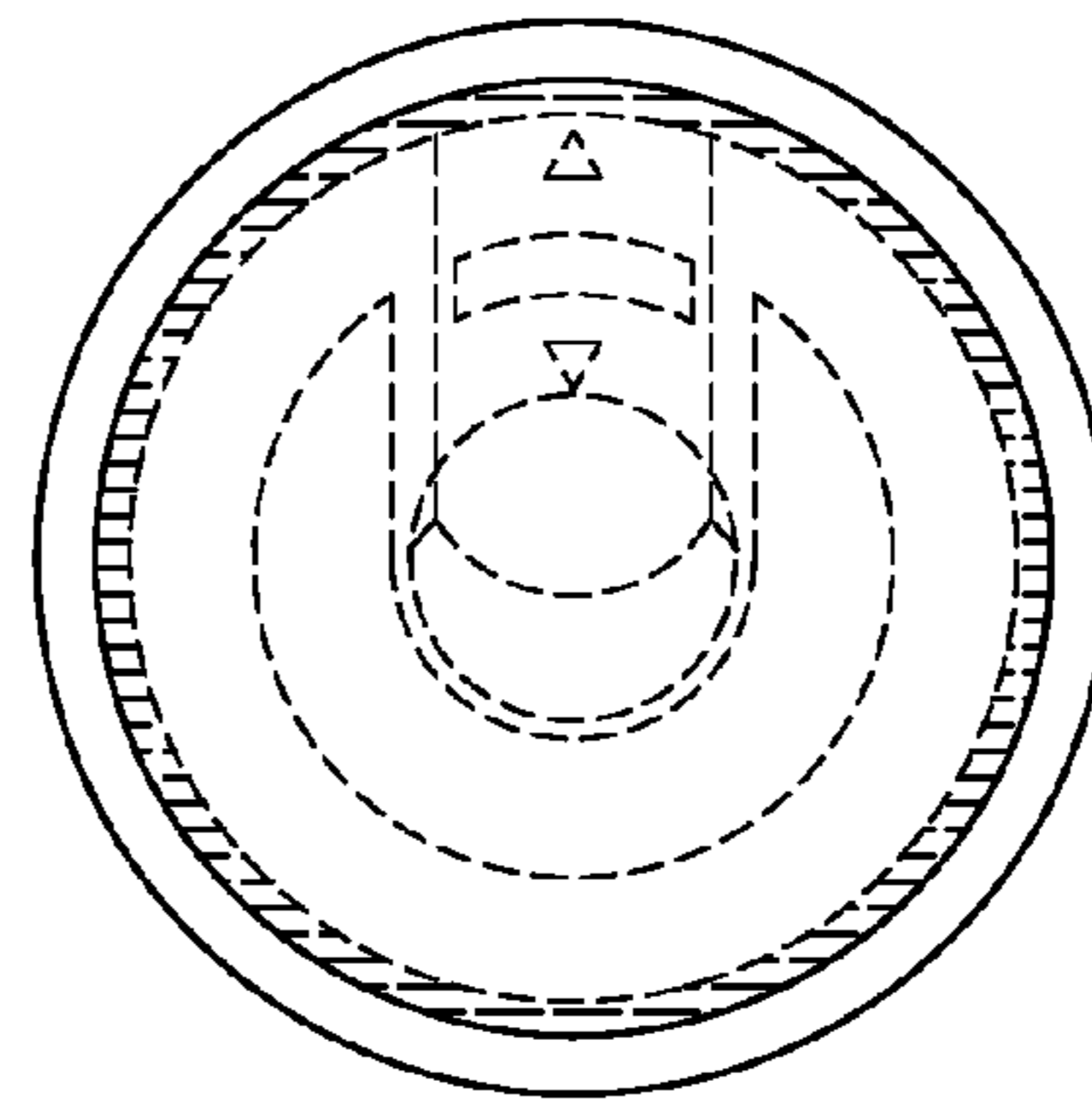

FIG. 35

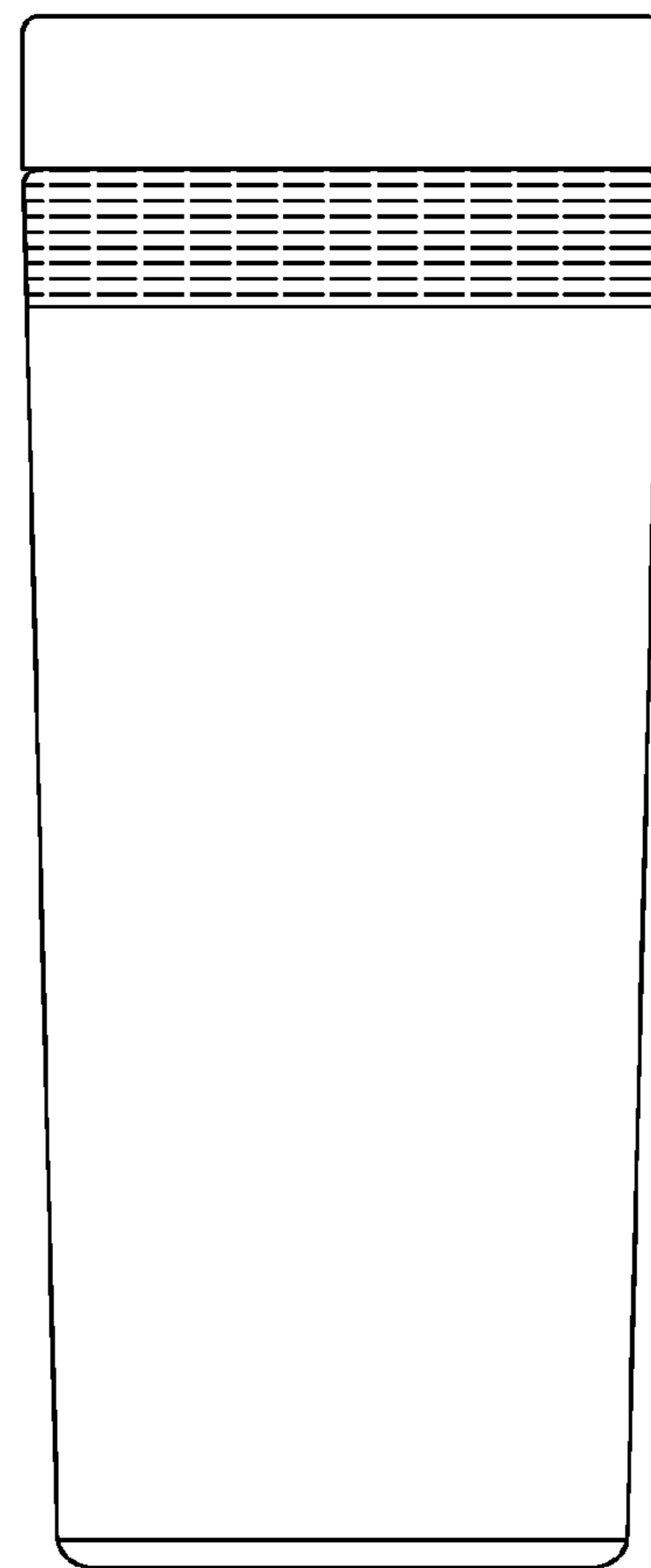

FIG. 34

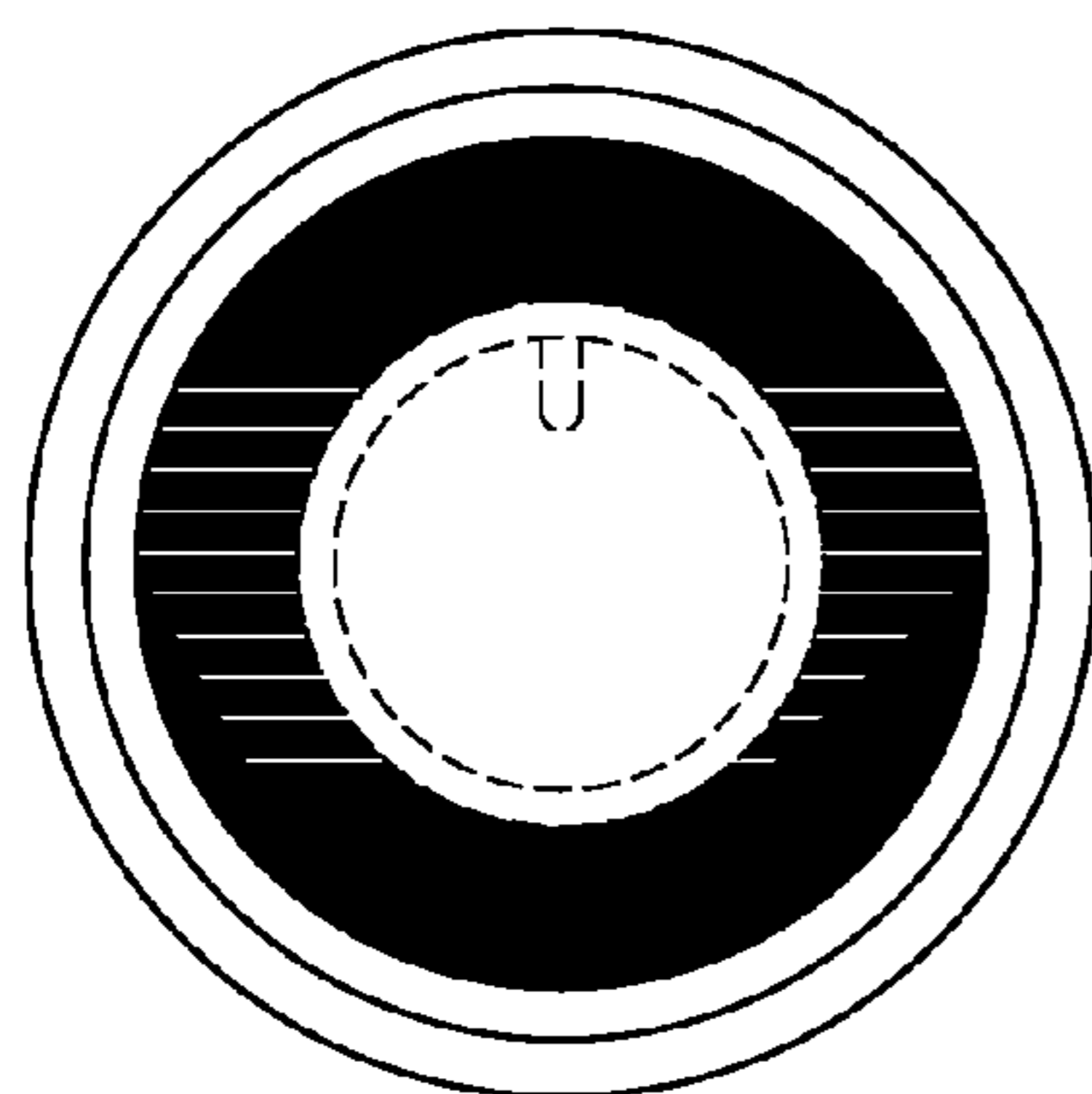

FIG. 36



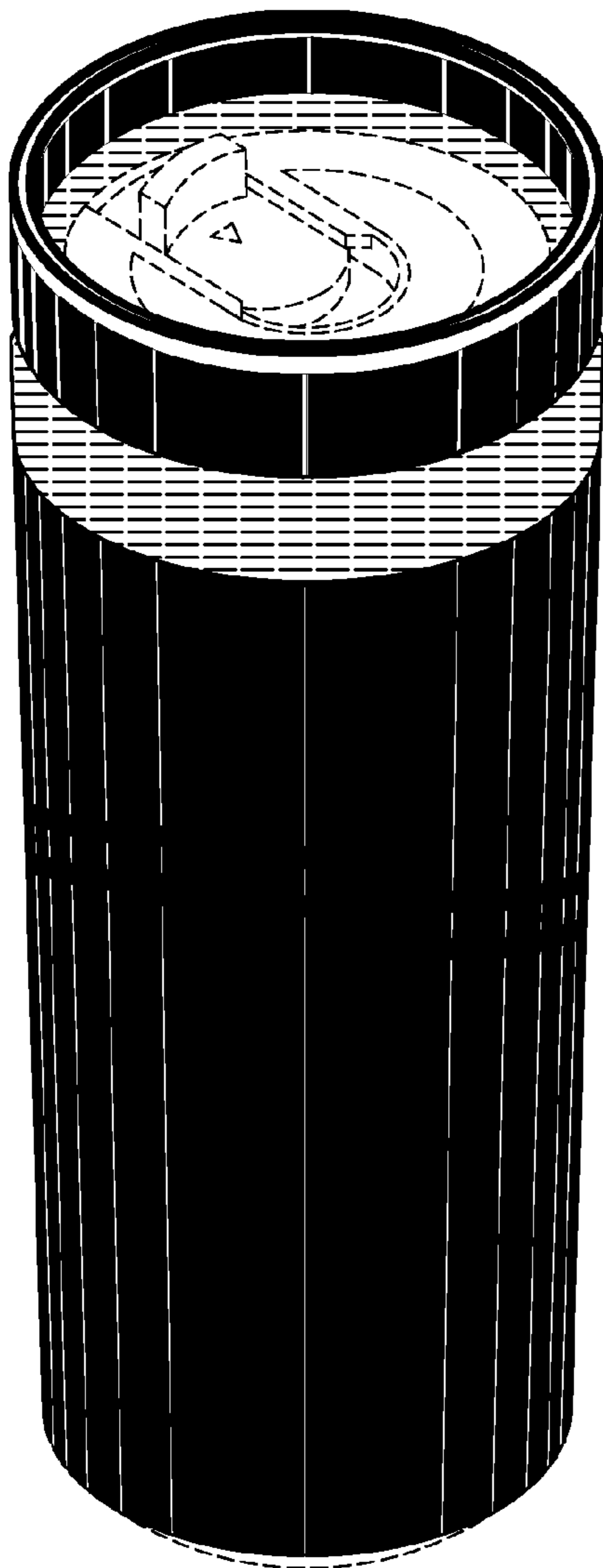

FIG. 37

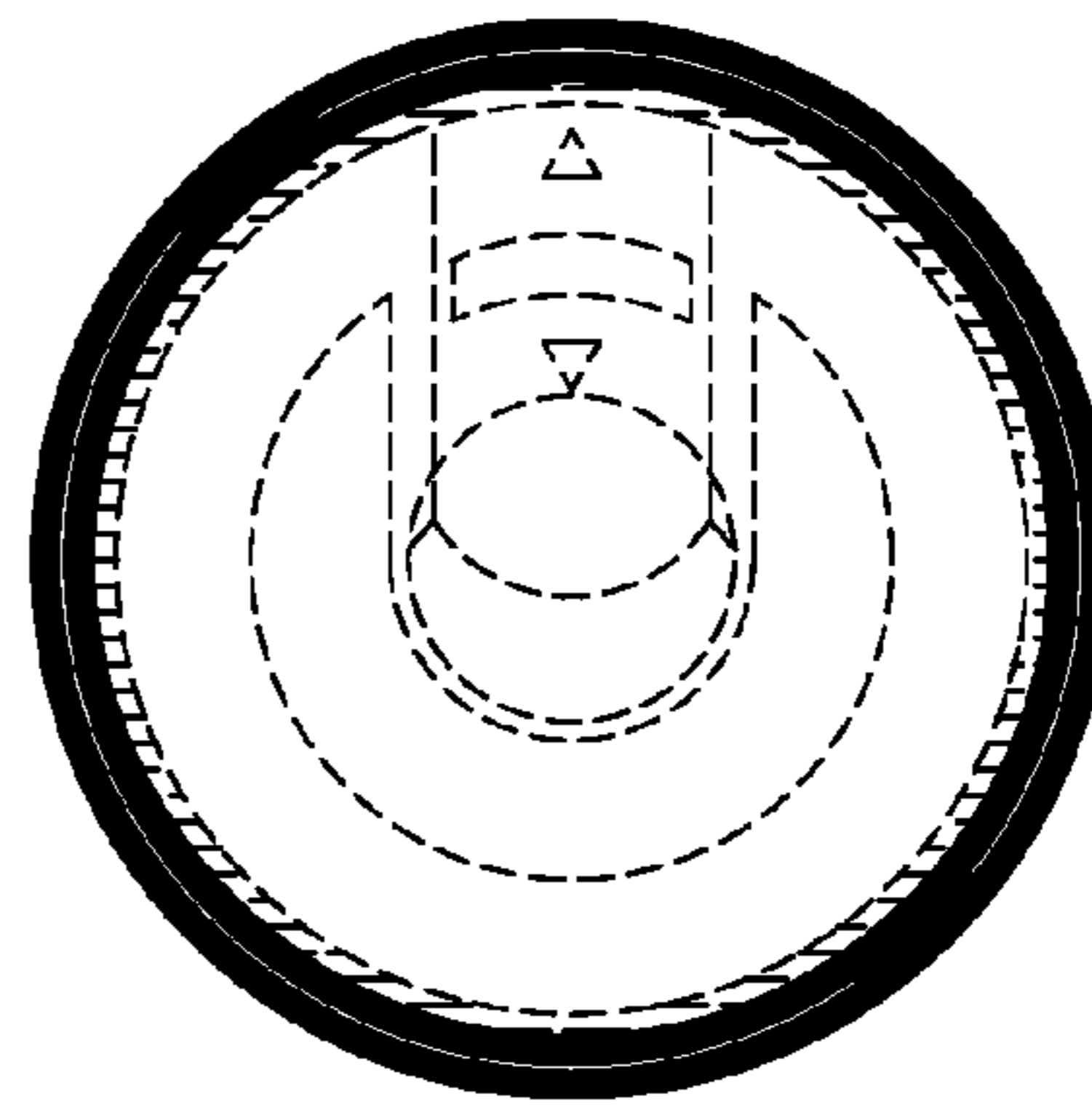

FIG. 39

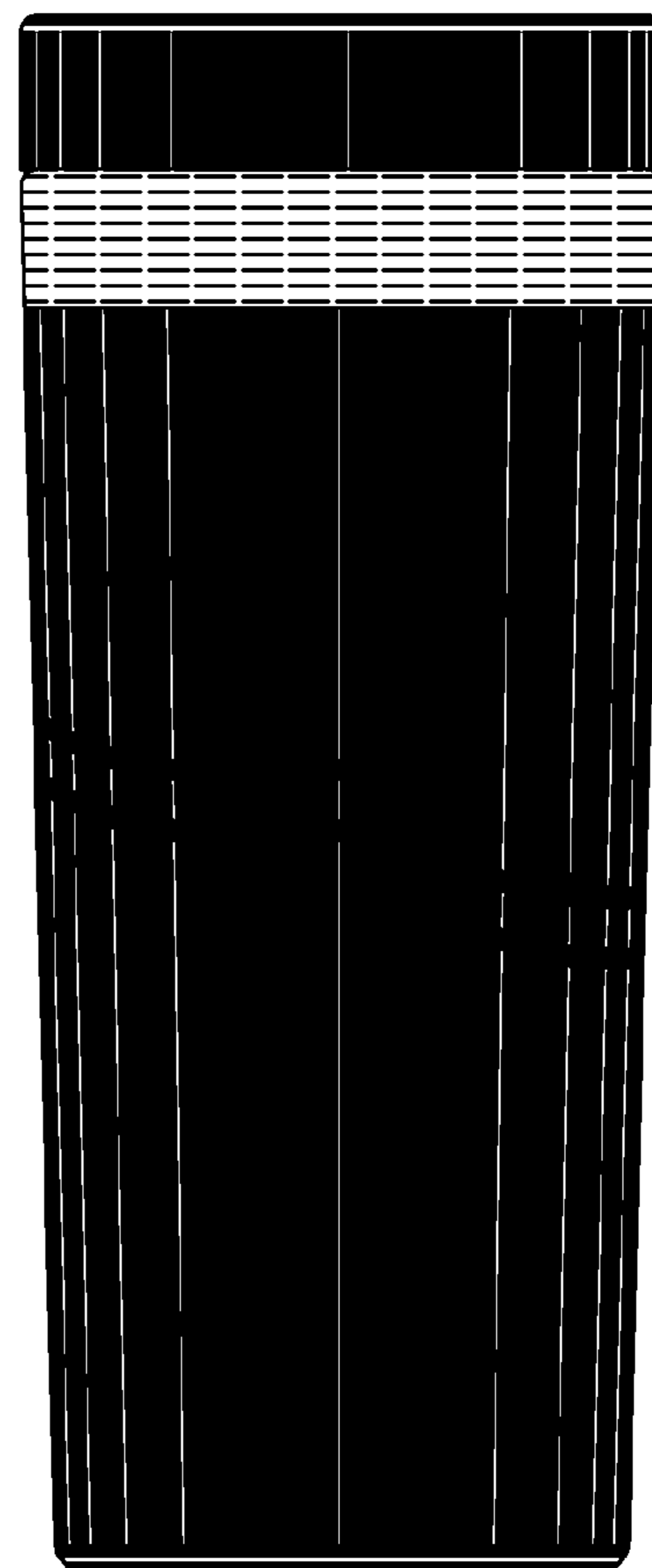

FIG. 38

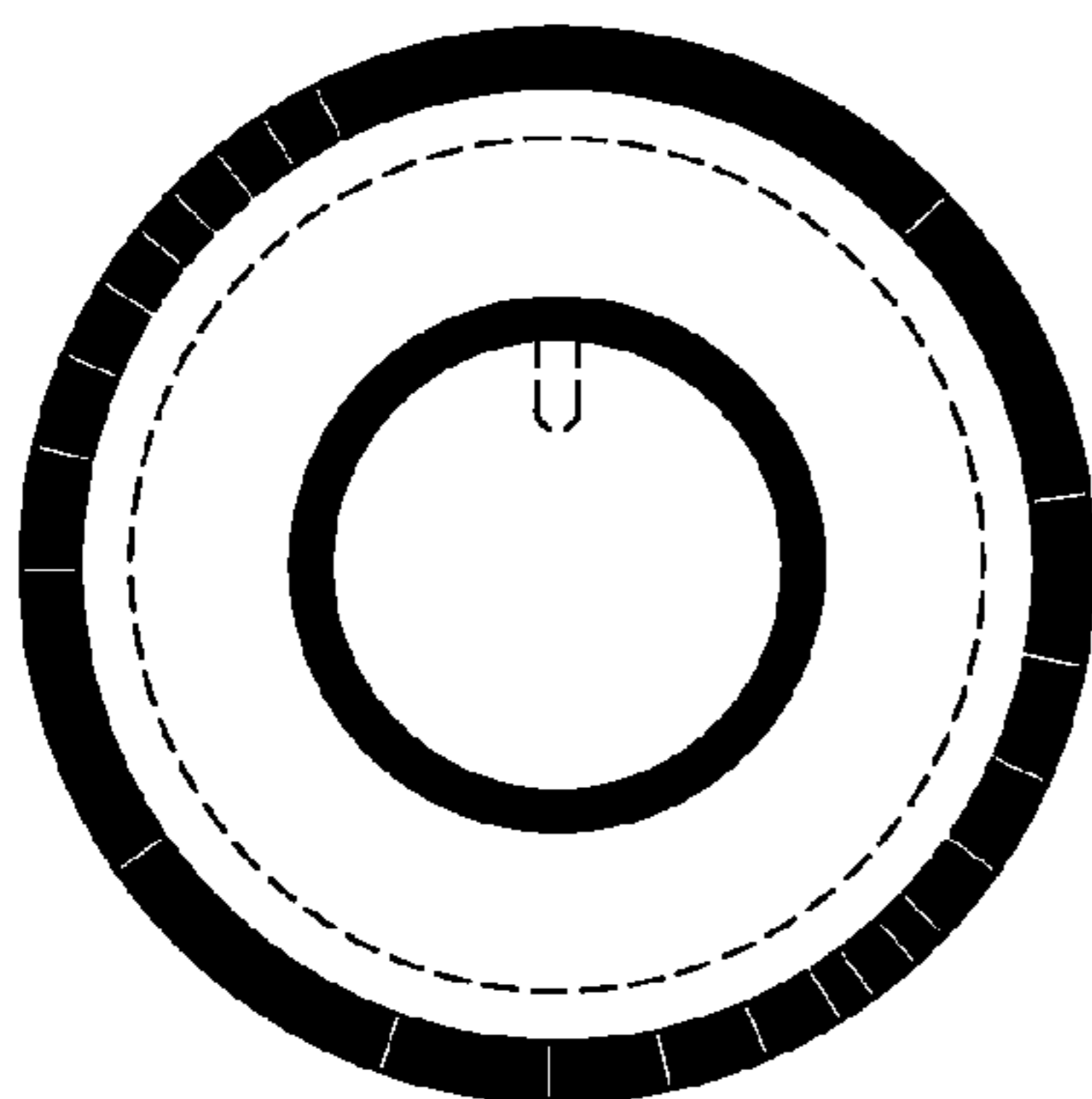

FIG. 40

