



US00D586011S

(12) **United States Design Patent**
Pfeiffer

(10) **Patent No.:** **US D586,011 S**
(45) **Date of Patent:** **** Feb. 3, 2009**

- (54) **HEADLIGHT FOR A VEHICLE**
- (75) Inventor: **Peter Pfeiffer**, Boeblingen (DE)
- (73) Assignee: **Daimler AG**, Stuttgart (DE)
- (**) Term: **14 Years**
- (21) Appl. No.: **29/290,364**
- (22) Filed: **Nov. 27, 2007**

Related U.S. Application Data

- (62) Division of application No. 29/233,873, filed on Jul. 12, 2005, now Pat. No. Des. 565,210.
- (51) **LOC (9) Cl.** **26-06**
- (52) **U.S. Cl.** **D26/28**
- (58) **Field of Classification Search** D26/28-36;
362/459-468, 475-478, 485-487
See application file for complete search history.

(56) **References Cited**

U.S. PATENT DOCUMENTS

D536,113 S	1/2007	Pfeiffer	
D542,442 S	5/2007	Matsunami	
D544,614 S	6/2007	Markefka	
D546,486 S *	7/2007	Sinkwitz	D26/28
D550,871 S	9/2007	Conway et al.	
D554,780 S *	11/2007	Sinkwitz	D26/28
D556,349 S *	11/2007	Golden et al.	D26/28

OTHER PUBLICATIONS

- Auto Bild, Version Nov. 2005, Mar. 18, 2005.
- Auto Bild, Nr. 1, Jan. 7, 2005.
- Auto Bild, Nr. 11, Mar. 18, 2005.
- Auto Bild, Nr. 18, Apr. 30, 2004.
- Auto motor und sport, Jul. 2003.

Auto motor und sport, "Auf Grosser Fahrt," Booklet 21, Sep. 29, 2004, pp. 1-6.
 Auto Strasseverkehr, "Daimlers Neuer Chic," Dec. 3, 2004, pp. 1-4.
 Auto Zeitung, "C-Klasse von morgen," p. 11, Version Nov. 2003, May 7, 2003.
 Auto Zeitung, p. 14, Version 13/2003, Jun. 4, 2003.
 Auto Zeitung, p. 14, Version 13/2004, Jun. 2, 2004.
 Weyer, Peter, "Neuer Schwung," stern, Feb. 10, 2005, pp. 1-2. Auto Bild.

* cited by examiner

Primary Examiner—Marcus A. Jackson

(74) *Attorney, Agent, or Firm*—Crowell & Moring LLP

(57) **CLAIM**

The ornamental design for a headlight for a vehicle, as shown and described.

DESCRIPTION

This application is related to the following applications, of the inventor: Application Ser. No. 29/233,903, entitled "Surface Configuration of a Vehicle, Toy, and/or Other Replicas," now U.S. patent No. D540,216; and Application Ser. No. 29/233,904, entitled "Surface Configuration of a Vehicle, Toy, and/or Other Replicas".

FIG. 1 is a perspective view of a first embodiment of a headlight for a vehicle according to my novel design;

FIG. 2 is a front view thereof; and

FIG. 3 is a side view thereof.

FIG. 4 is a perspective view of a second embodiment of the headlight for a vehicle according to my novel design;

FIG. 5 is a front view thereof; and,

FIG. 6 is a side view thereof.

The broken lines are for illustrative purposes only and form no part of the claimed design.

1 Claim, 4 Drawing Sheets

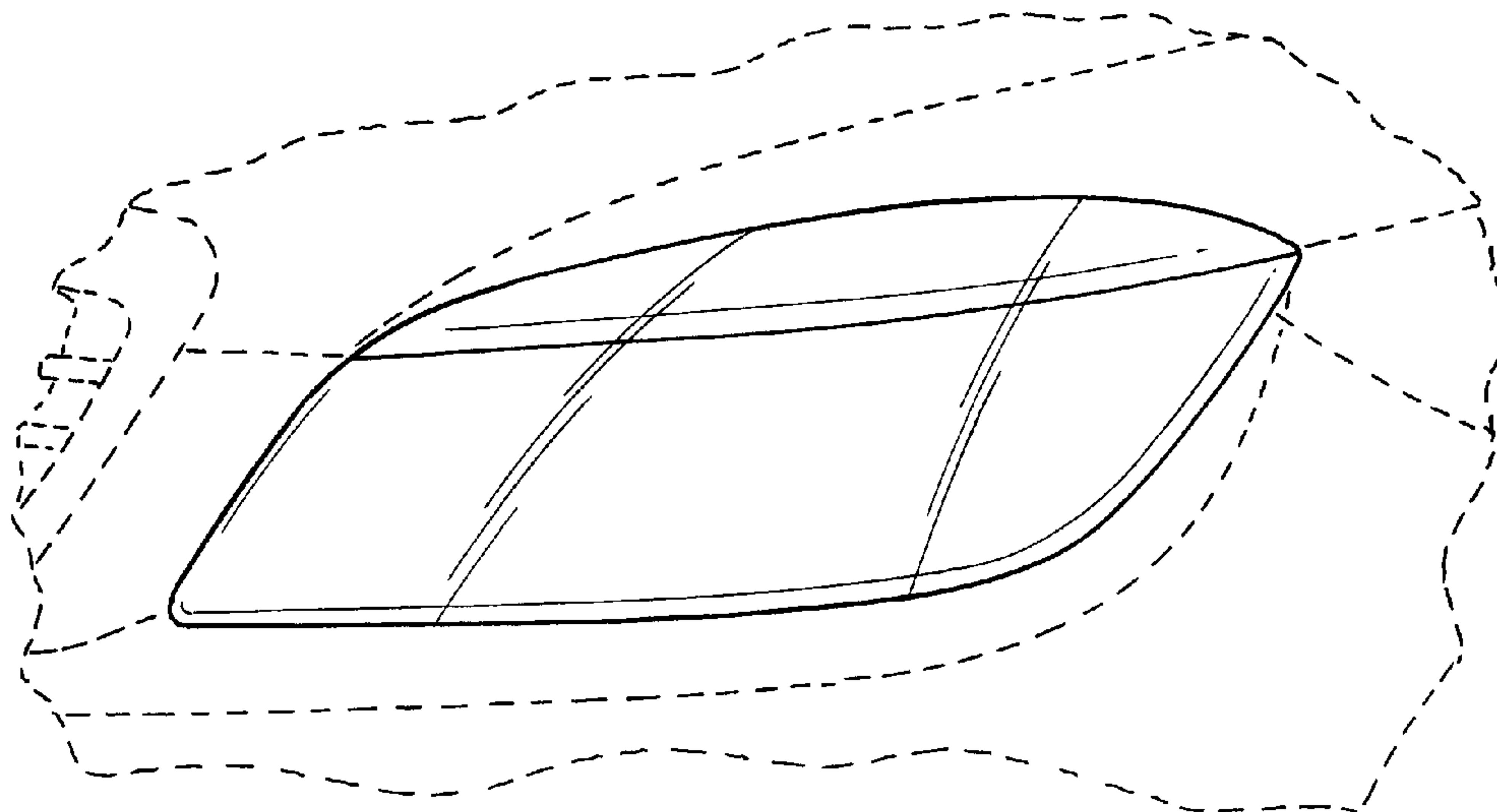

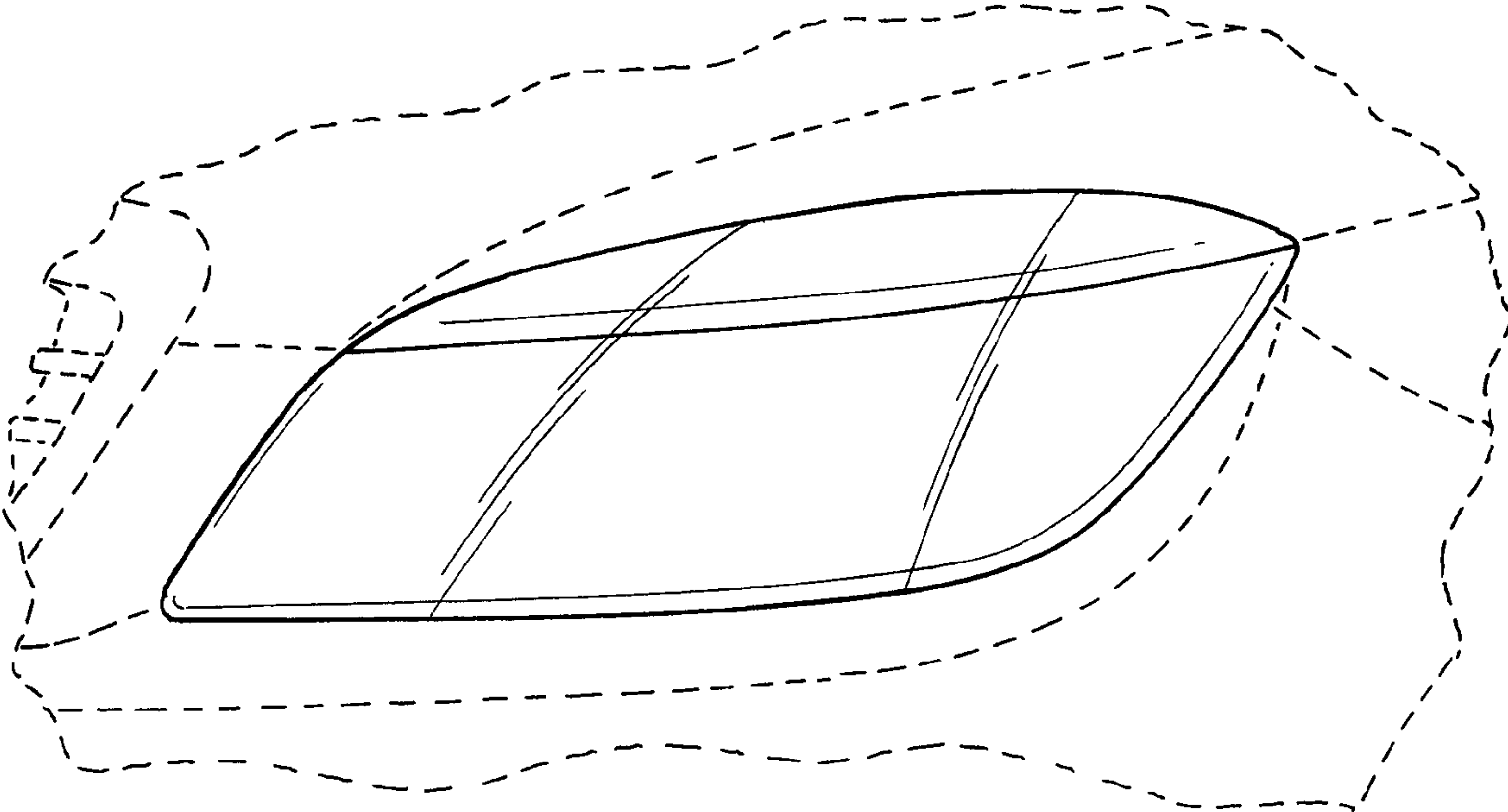

FIG. 1

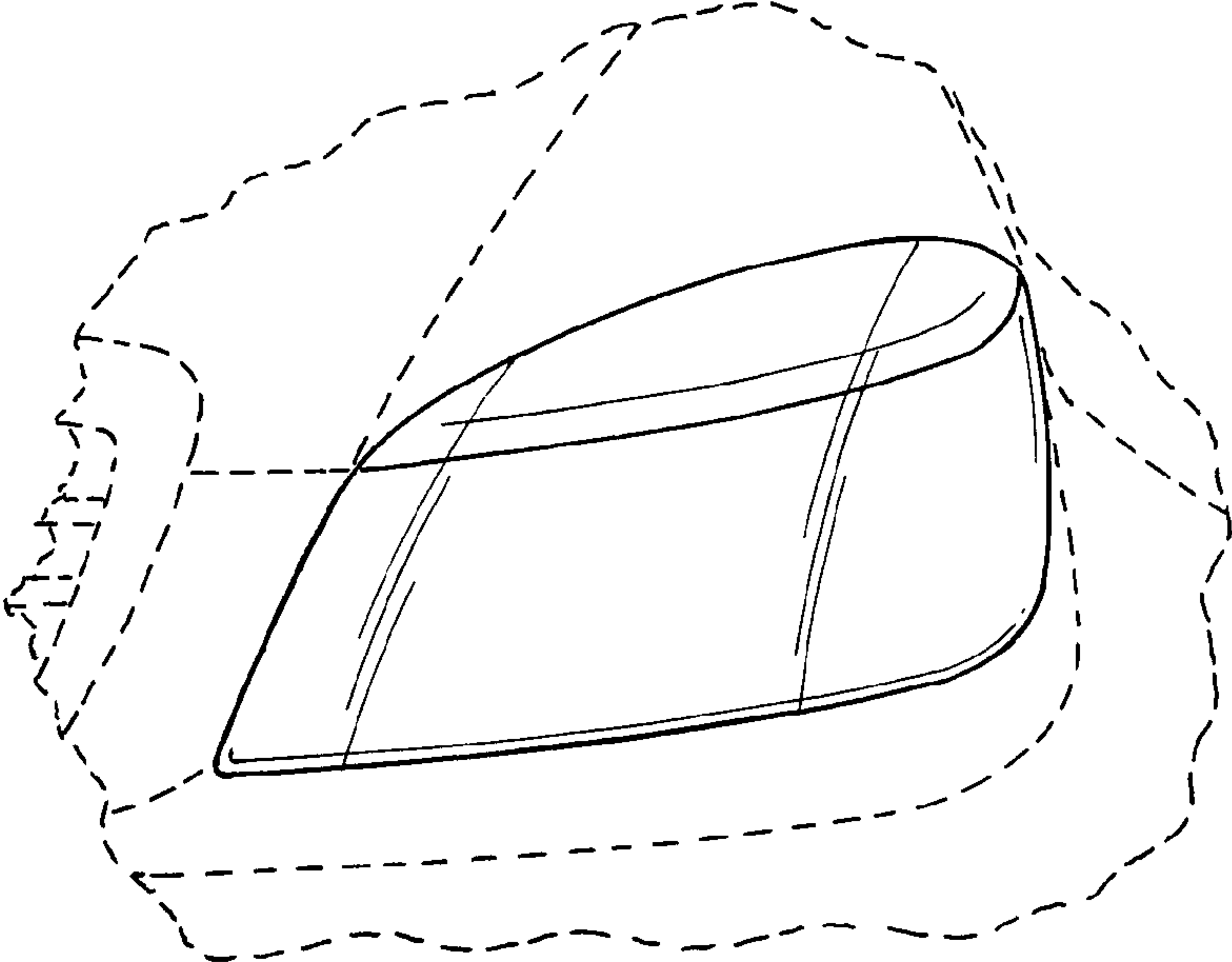

FIG. 2

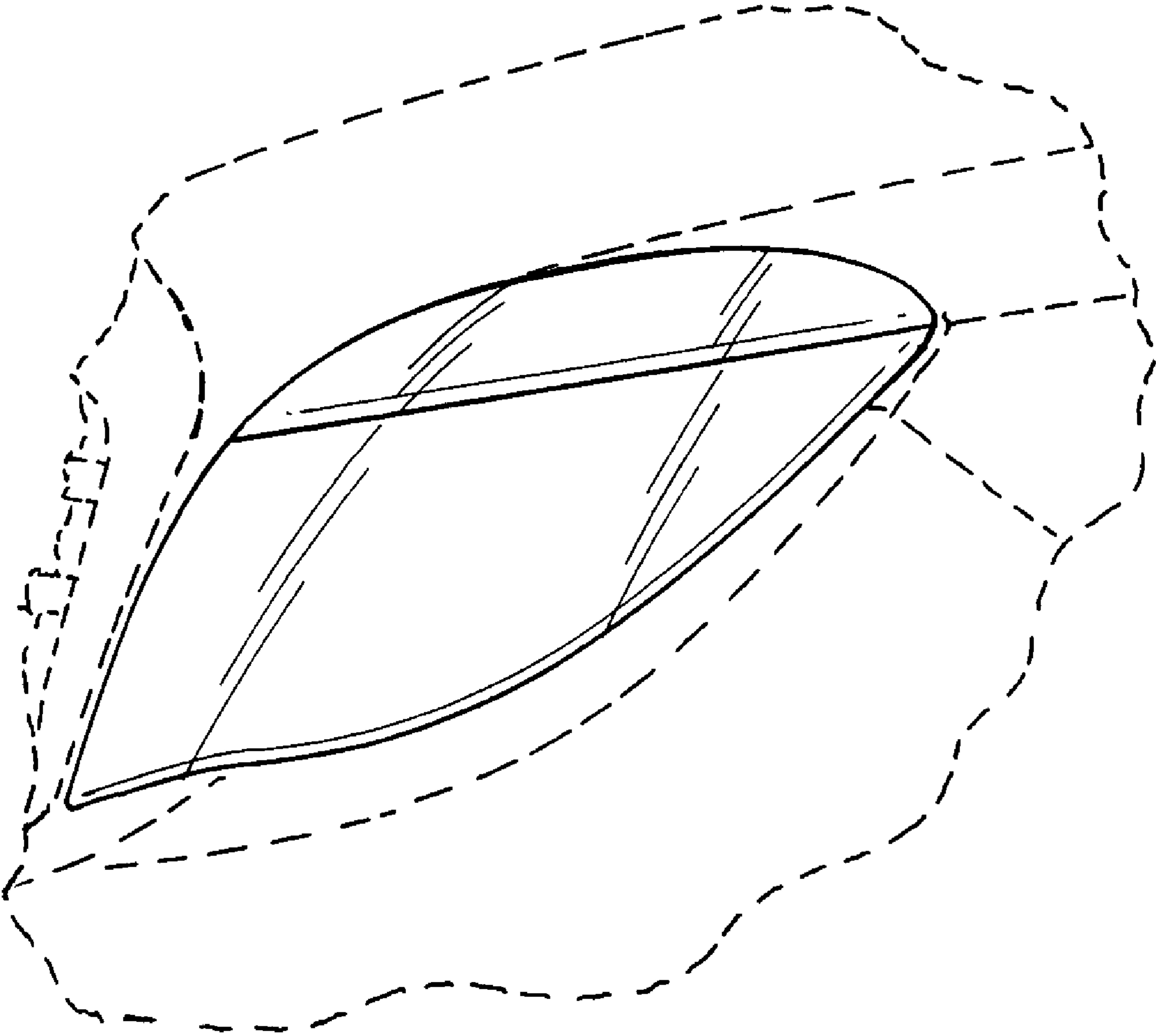

FIG. 3

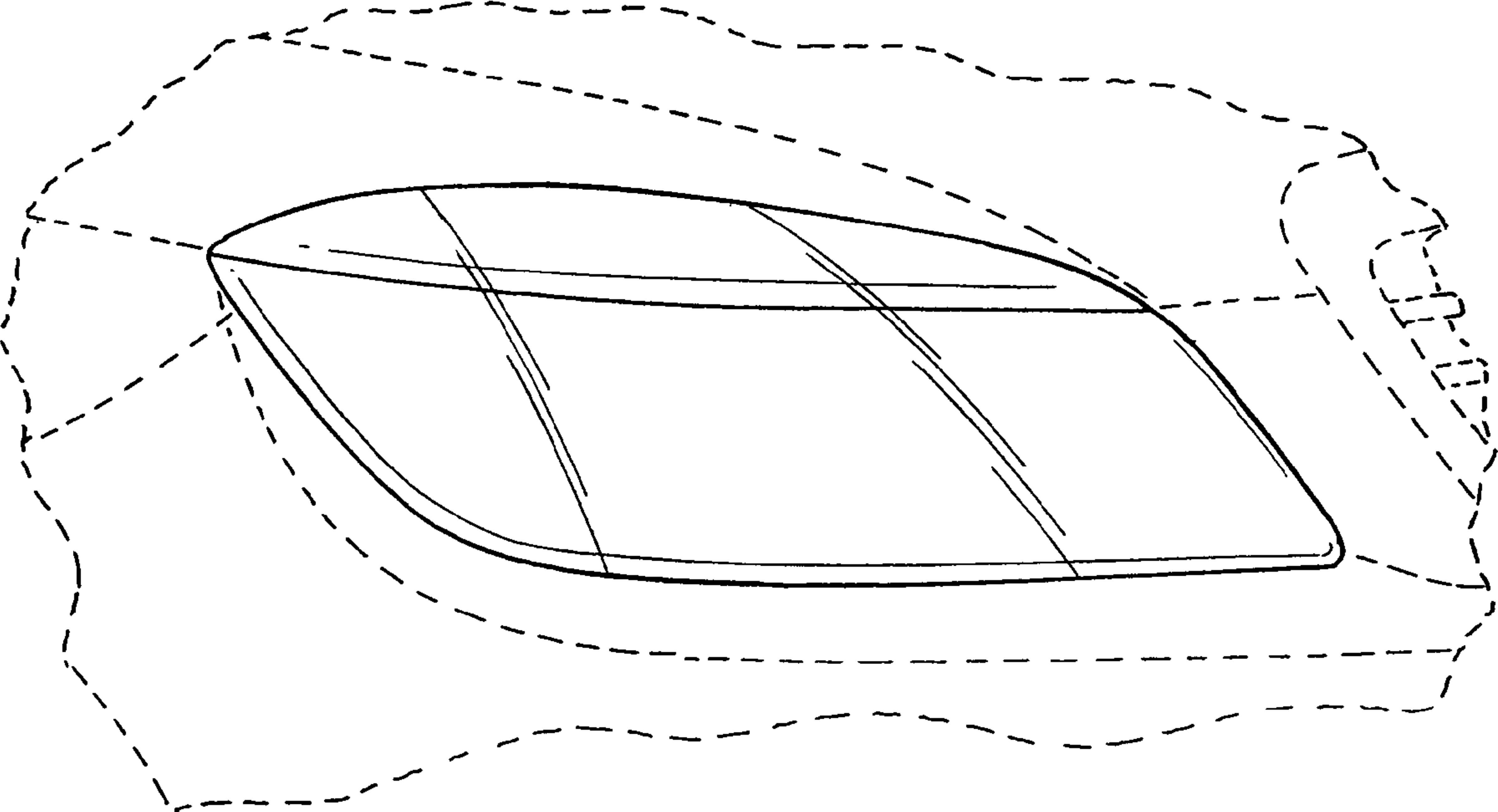

FIG. 4

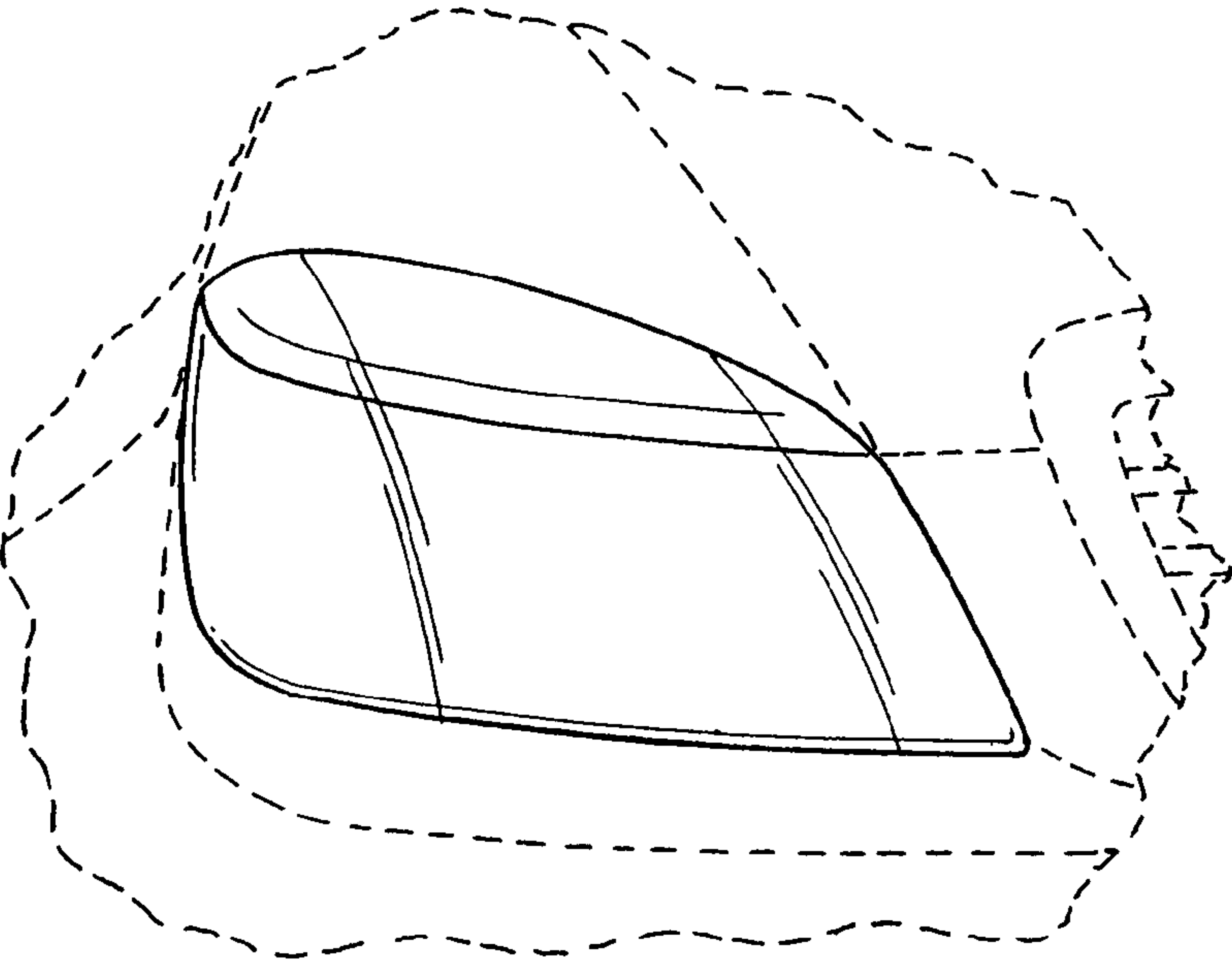

FIG. 5

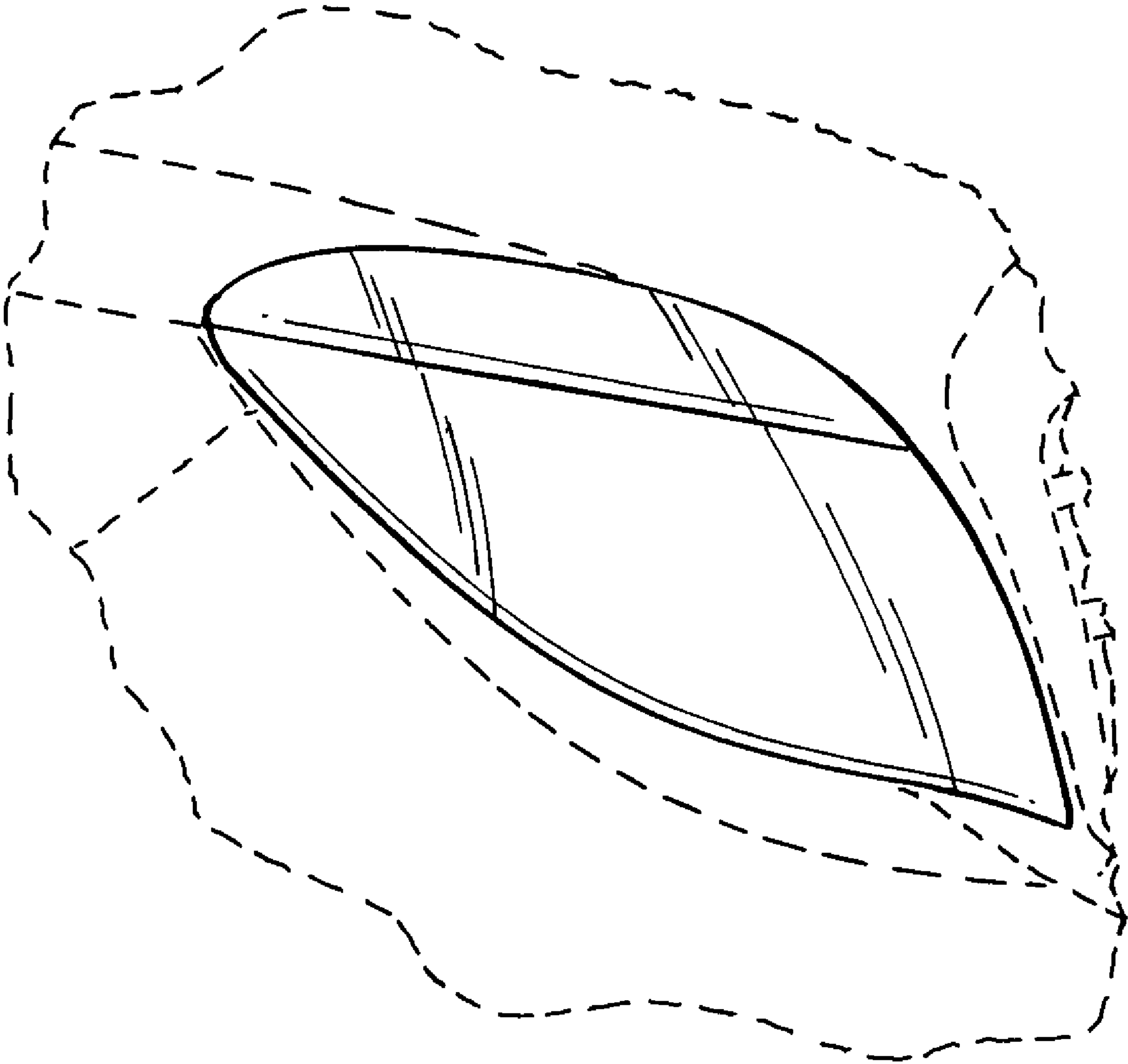

FIG. 6