



US00D585808S

(12) **United States Design Patent**
Hetrick

(10) **Patent No.:** **US D585,808 S**

(45) **Date of Patent:** **** Feb. 3, 2009**

(54) **VEHICLE-WHEEL FRONT FACE**

(75) Inventor: **Steven Hetrick**, Westminster, CA (US)

(73) Assignee: **Mobile Hi-Tech Wheels**, Garden Grove, CA (US)

(**) Term: **14 Years**

(21) Appl. No.: **29/308,477**

(22) Filed: **Jun. 18, 2008**

(51) **LOC (9) Cl.** **12-16**

(52) **U.S. Cl.** **D12/211**

(58) **Field of Classification Search** D12/204-213;
301/37.101, 64.101, 65, 64.201

See application file for complete search history.

(56) **References Cited**

U.S. PATENT DOCUMENTS

D446,493	S	*	8/2001	Sulahian et al.	D12/211
D454,107	S	*	3/2002	Chung	D12/211
D458,208	S	*	6/2002	Hartl	D12/211
D490,040	S	*	5/2004	Foose	D12/211
D500,006	S	*	12/2004	Cahyono	D12/211
D535,242	S	*	1/2007	Lyew	D12/211
D555,568	S	*	11/2007	Hetrick	D12/211
D578,459	S	*	10/2008	Hetrick	D12/211

* cited by examiner

Primary Examiner—Stacia Cadmus

(74) *Attorney, Agent, or Firm*—Christie, Parker & Hale, LLP

(57) **CLAIM**

The ornamental design for vehicle-wheel front face, as shown and described.

DESCRIPTION

FIG. 1 is a perspective view of a vehicle-wheel front face according to my new design;

FIG. 2 is a front elevational view thereof;

FIG. 3 is a side elevational view thereof;

FIG. 4 is a second embodiment of my design using five spokes instead of six;

FIG. 5 is a front elevational view of the second embodiment;

FIG. 6 is a side elevational view of the second embodiment;

FIG. 7 is a third embodiment of my design using eight spokes;

FIG. 8 is a front elevational view of the third embodiment; and,

FIG. 9 is a side elevational view of the third embodiment.

The broken line showing of the rear of the wheel rim, the bolt holes, and the circular elements on the rim between the spokes is included for the purpose of illustrating environment and forms no part of the claimed design.

1 Claim, 9 Drawing Sheets

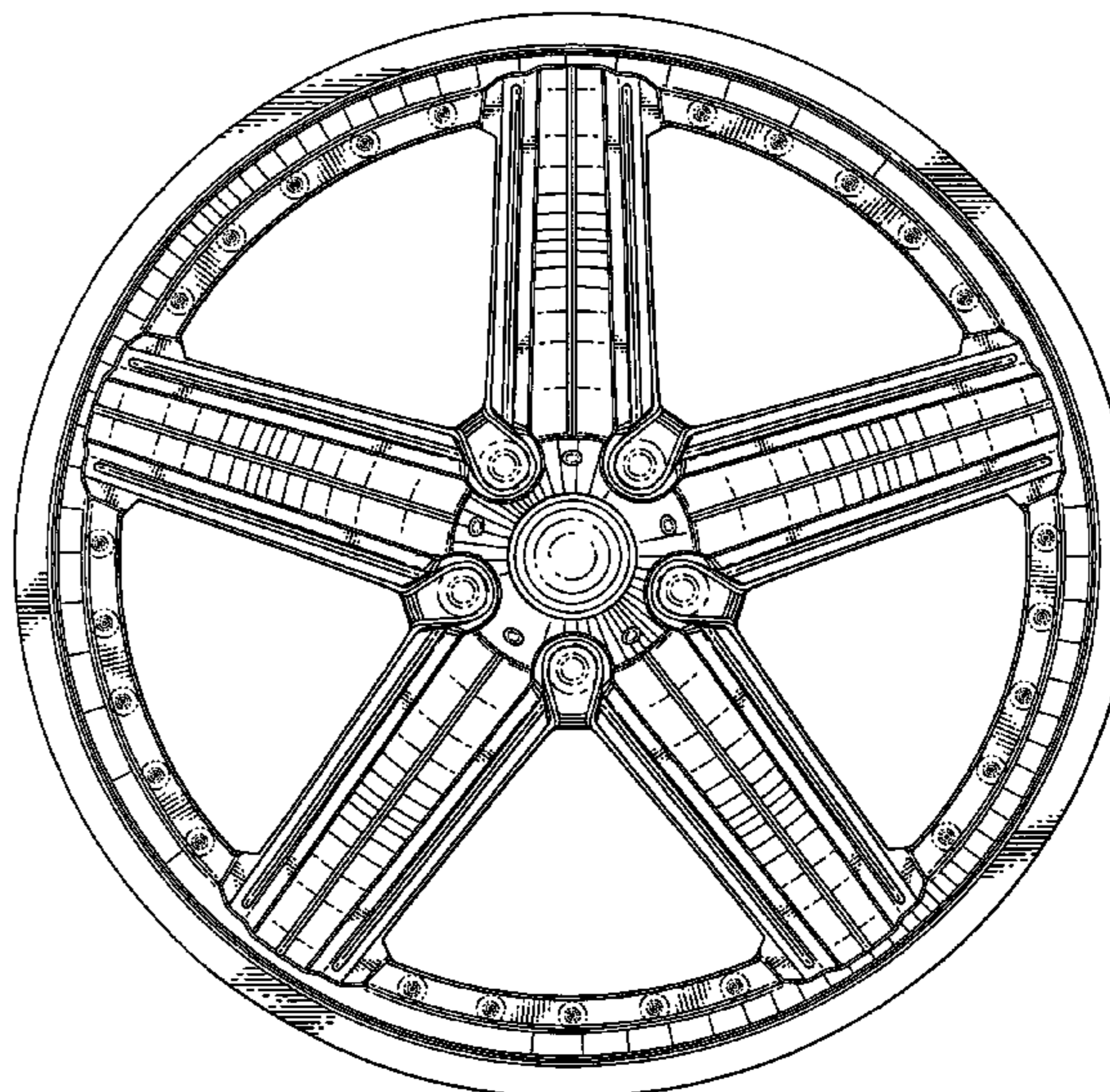
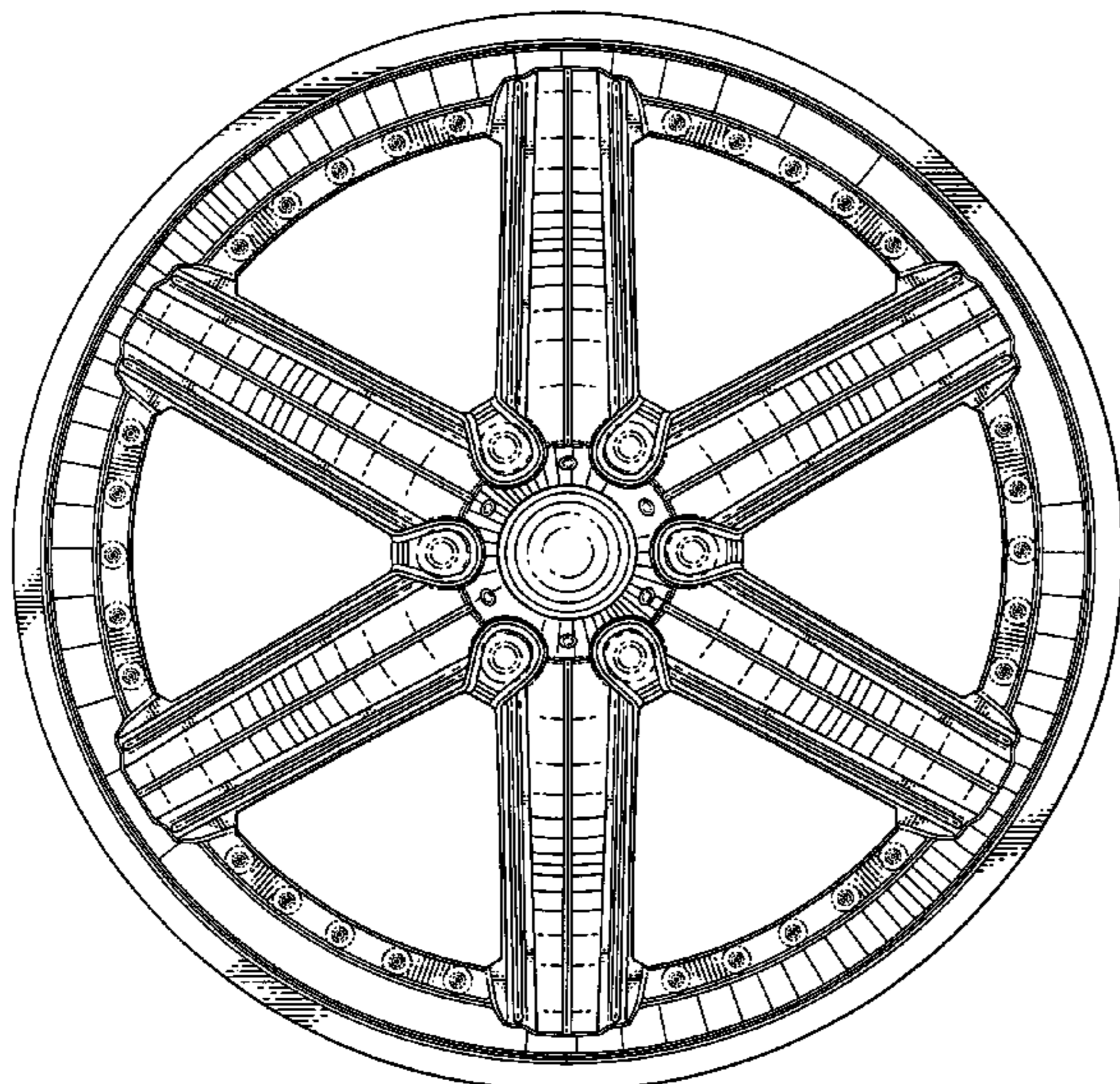

FIG. 1

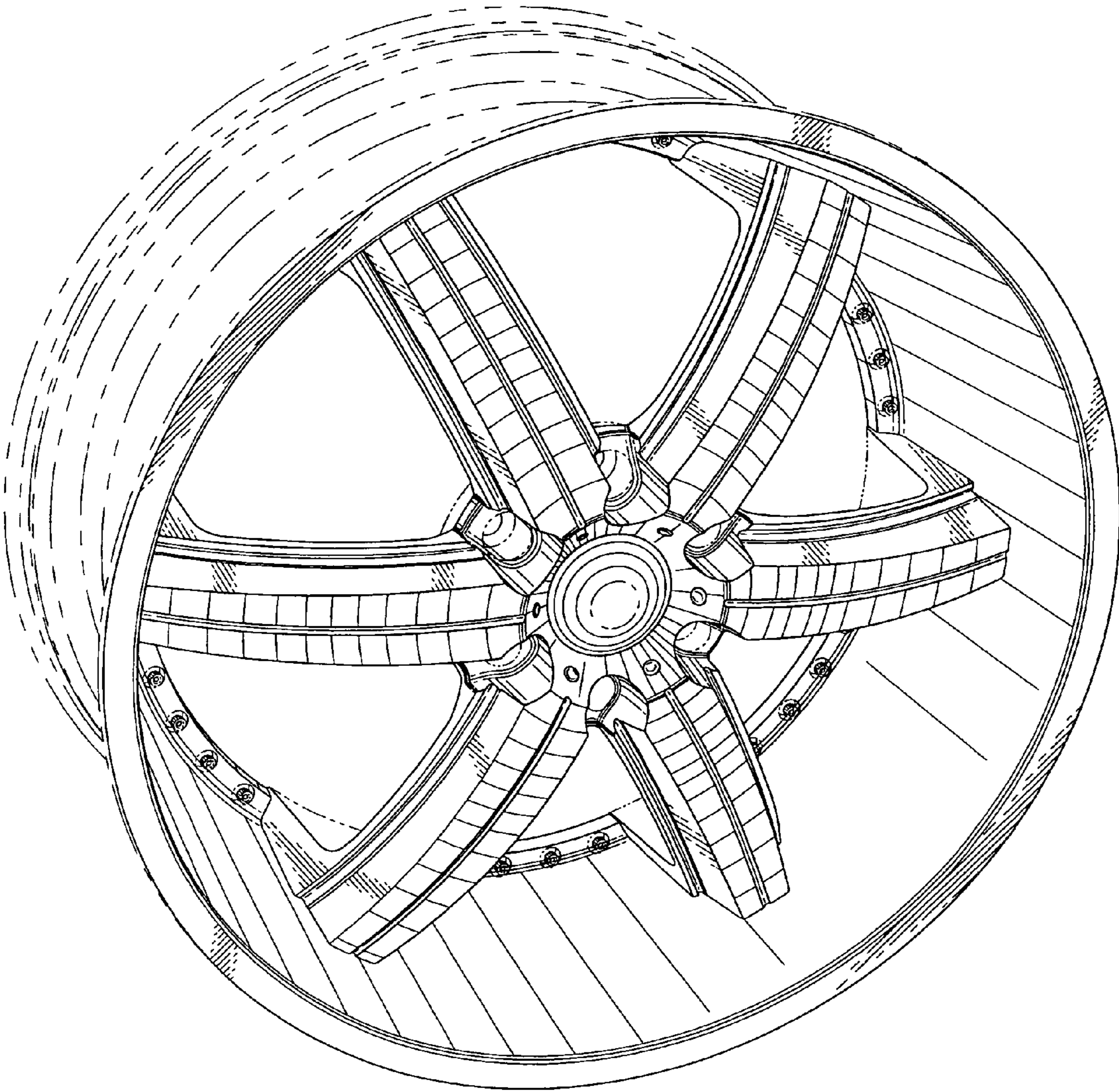

FIG. 2

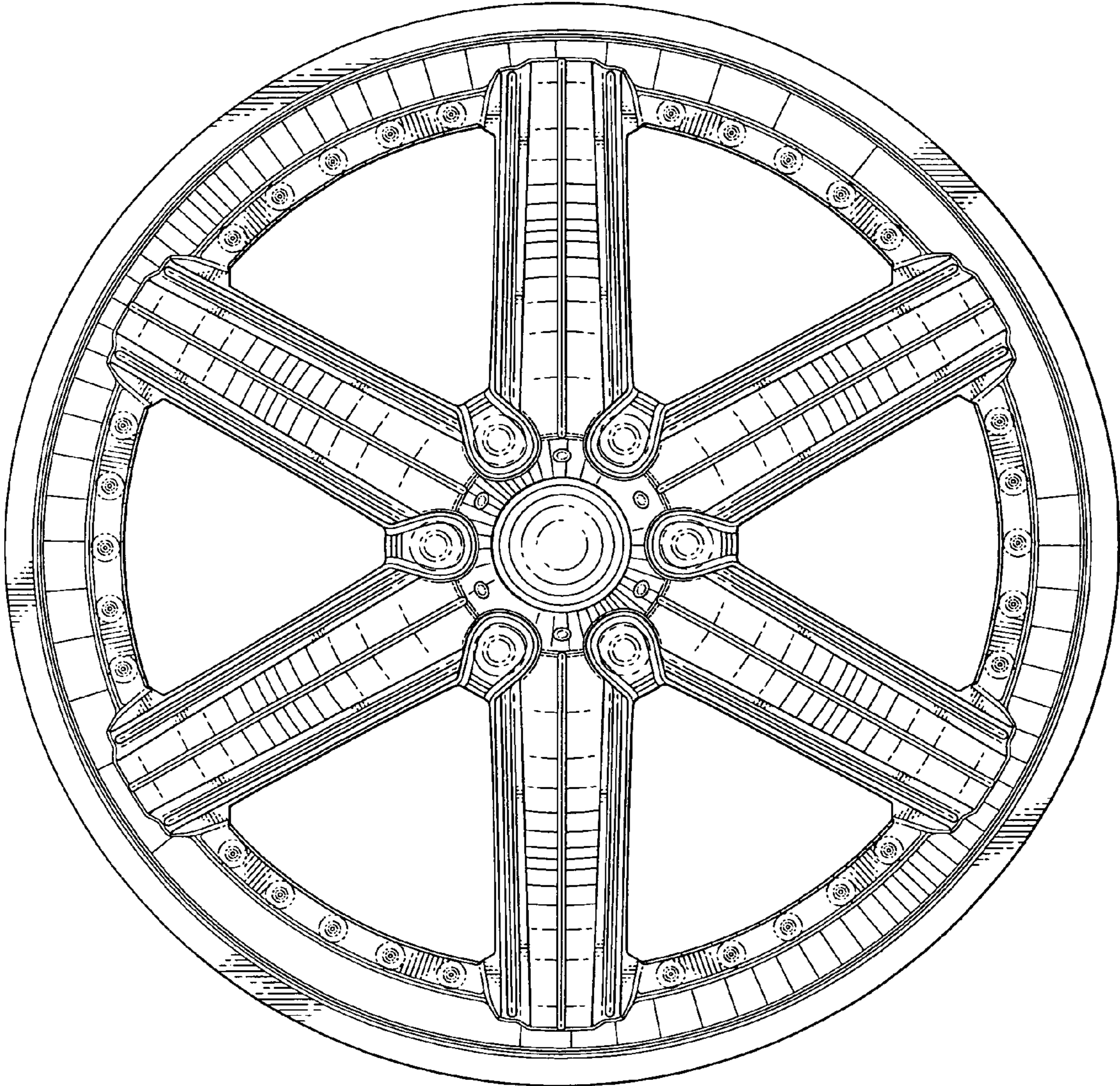

FIG. 3

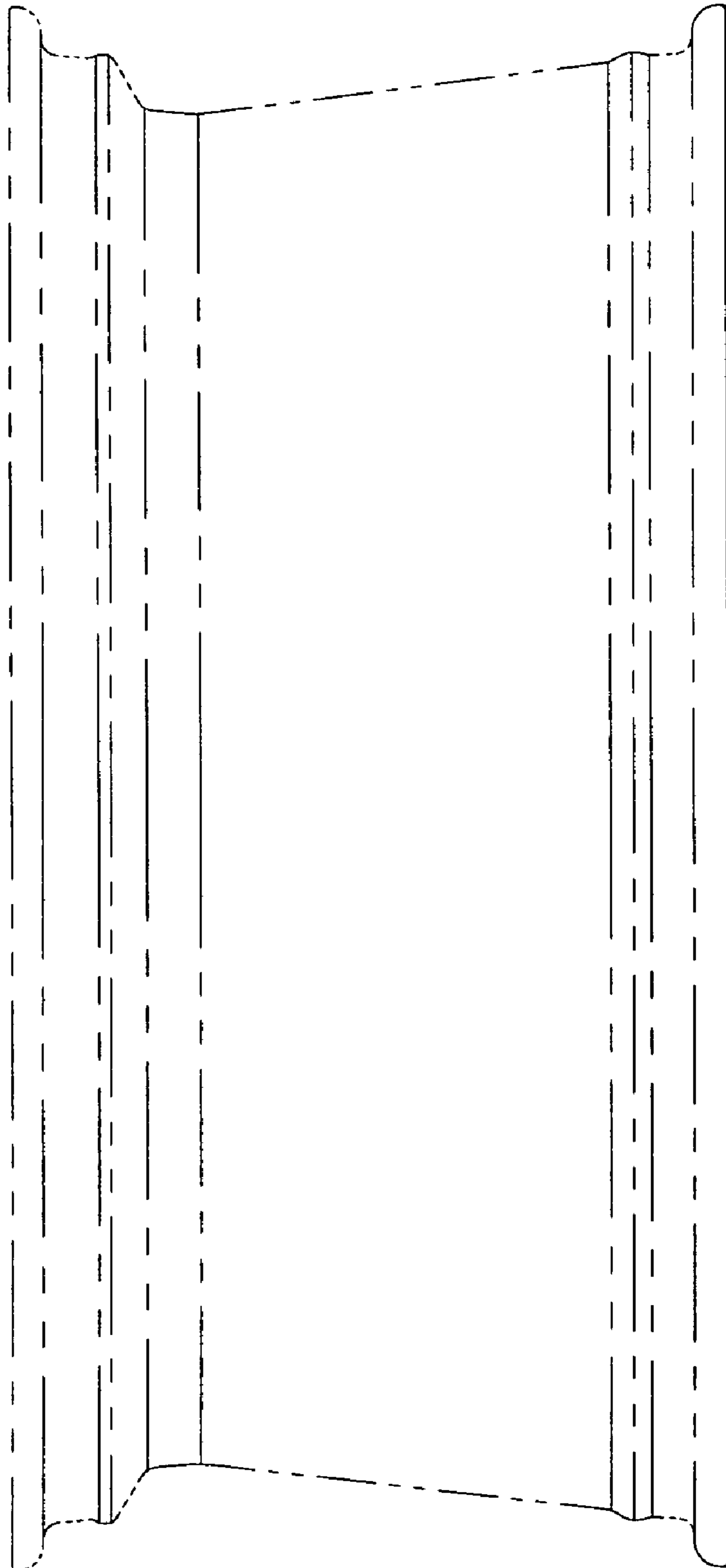

FIG. 4

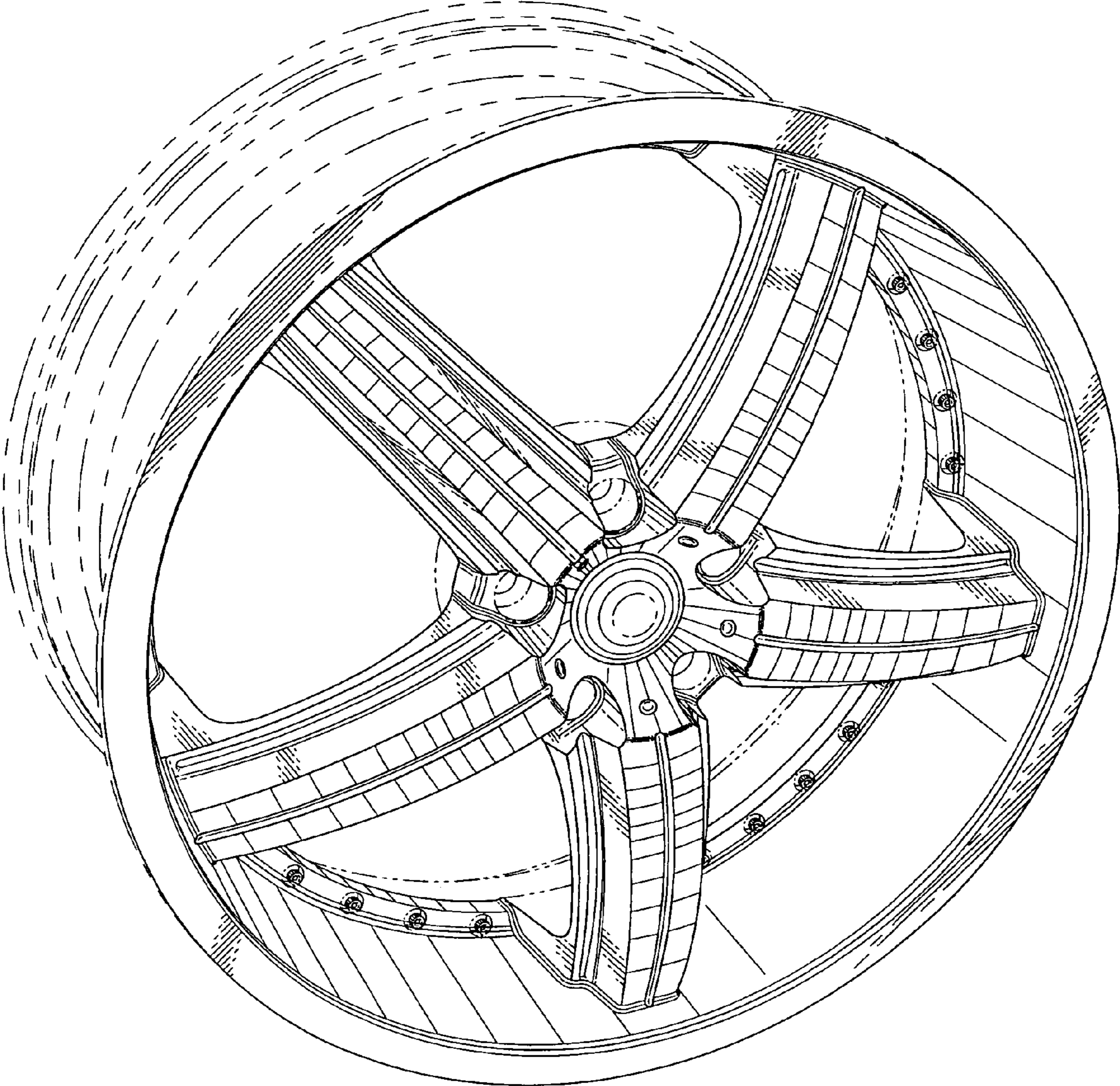

FIG. 5

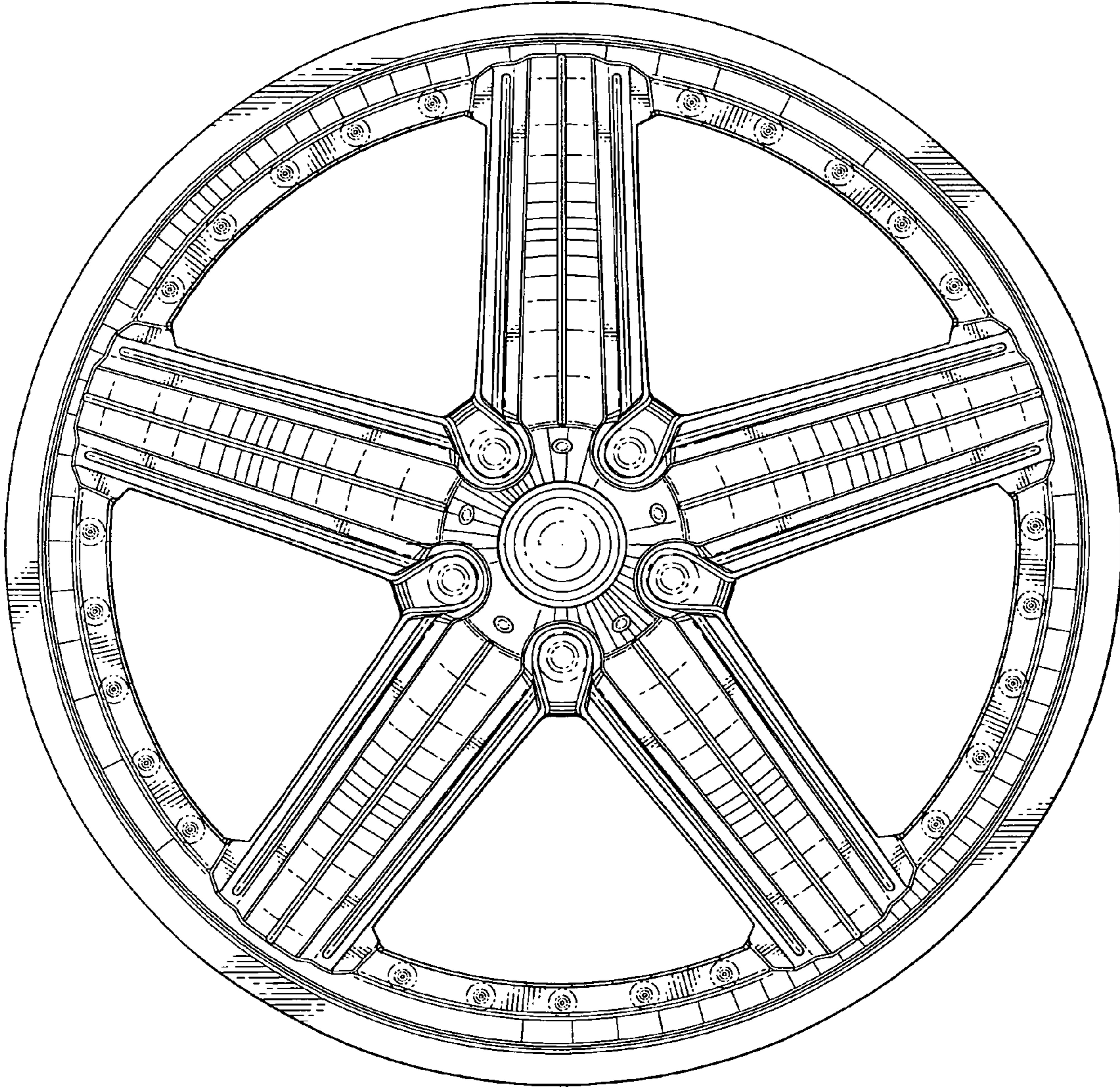

FIG. 6

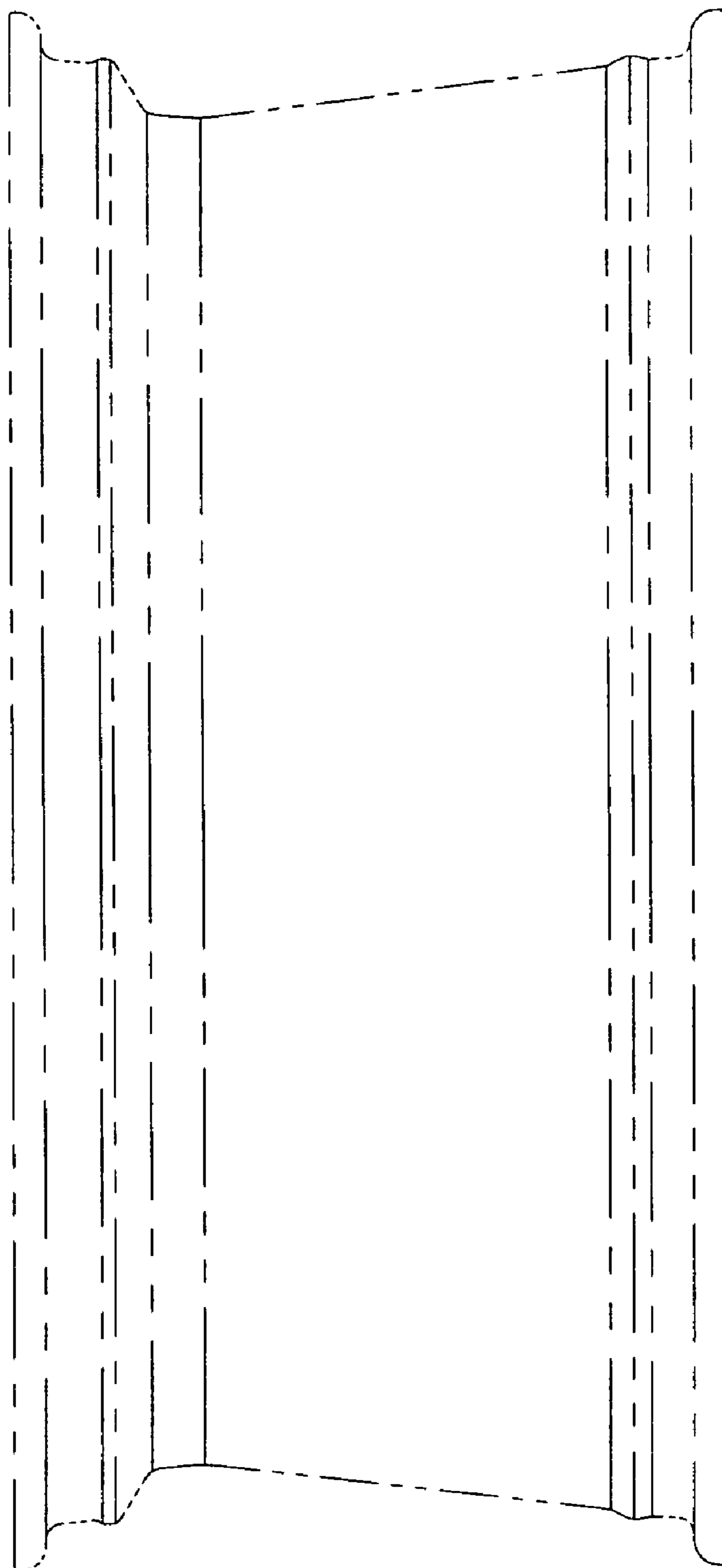

FIG. 7

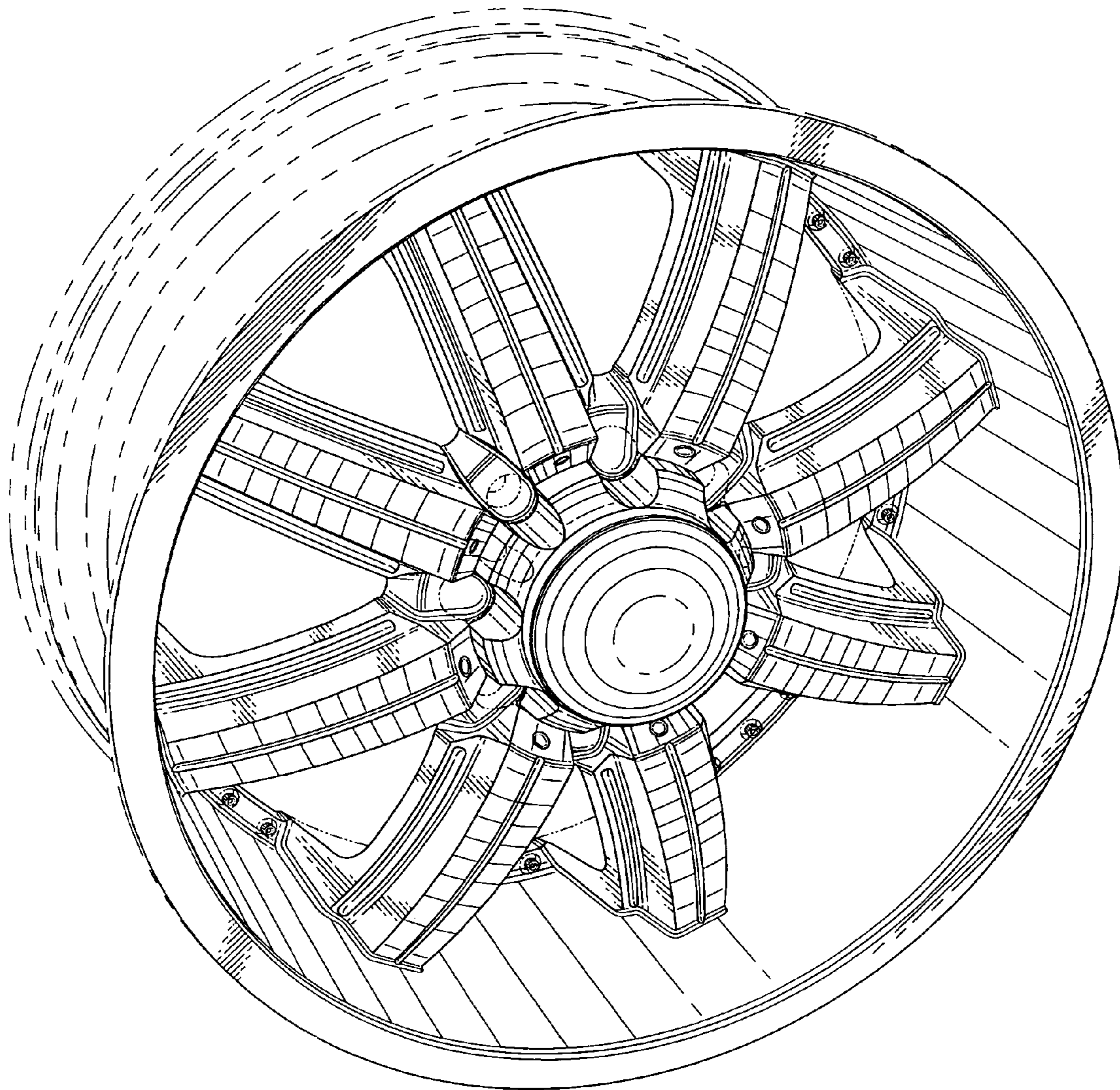

FIG. 8

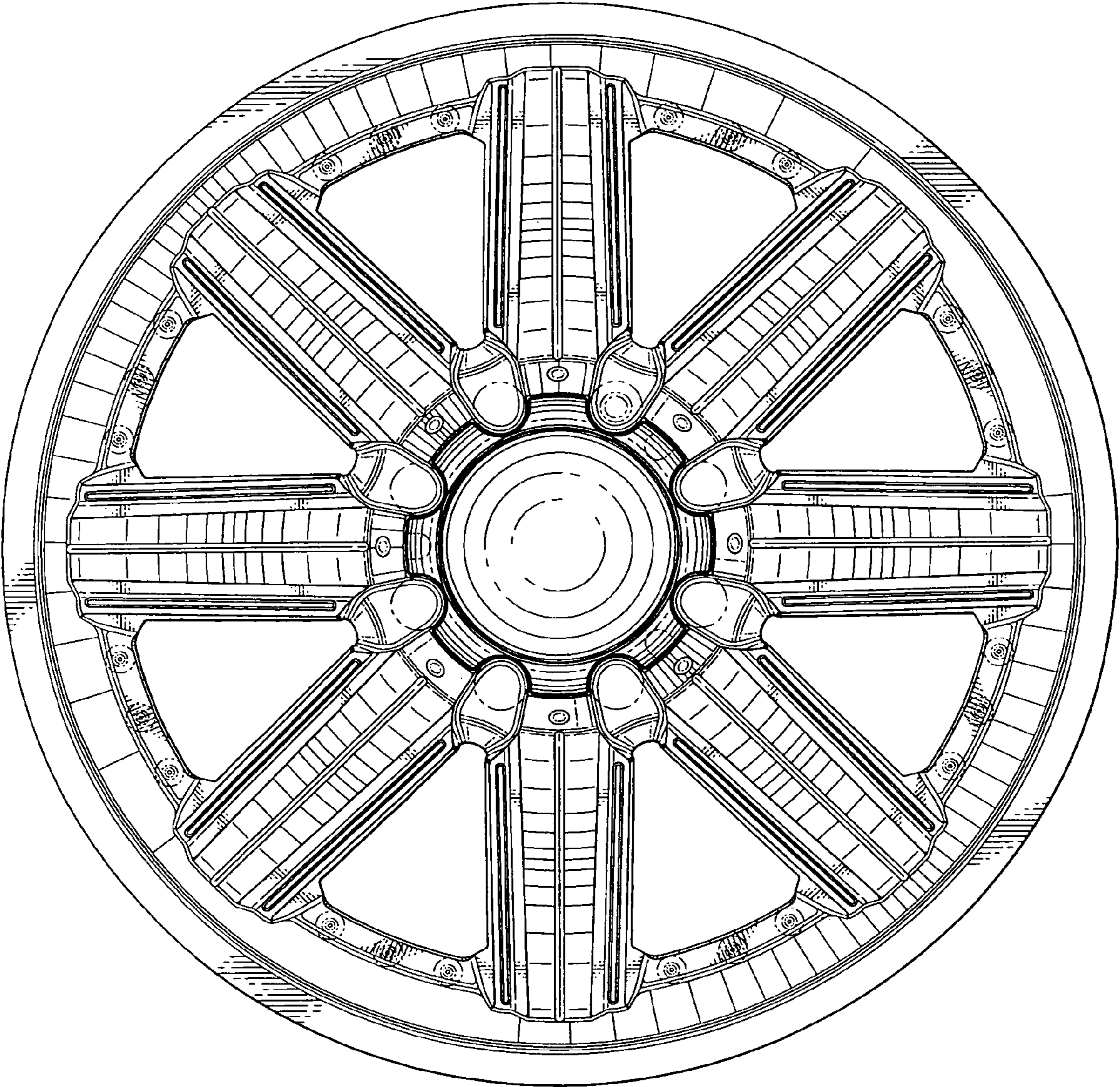

FIG. 9

