



US00D585666S

(12) **United States Design Patent**  
**Hamasaki**

(10) **Patent No.:** **US D585,666 S**

(45) **Date of Patent:** **\*\* Feb. 3, 2009**

(54) **DISPLAY STAND FOR MODEL AIRPLANE**

(75) Inventor: **Takashi Hamasaki**, Kanagawa Prefecture (JP)

(73) Assignee: **Kyosho Corporation**, Tokyo (JP)

(\*\*) Term: **14 Years**

(21) Appl. No.: **29/274,880**

(22) Filed: **Jun. 4, 2007**

(30) **Foreign Application Priority Data**

Jan. 31, 2007 (JP) ..... 2007-001949

(51) **LOC (9) Cl.** ..... **06-04**

(52) **U.S. Cl.** ..... **D6/457**

(58) **Field of Classification Search** ..... D6/457,  
D6/491, 493, 497, 509, 315, 316, 475, 495,  
D6/499, 520, 466, 349-351, 450, 462; 294/19.1,  
294/22; D20/30-32, 10, 41; 108/150; 297/461,  
297/195.11; D11/131, 157; 211/1, 34; D19/75,  
D19/97; D12/119; 40/1

See application file for complete search history.

(56) **References Cited**

**U.S. PATENT DOCUMENTS**

D195,213 S *	5/1963	Cook	.....	D6/511
D330,816 S *	11/1992	Phillips	.....	D6/457
D454,438 S *	3/2002	Volkman et al.	.....	D6/349
D454,706 S *	3/2002	Volkman et al.	.....	D6/349
D491,747 S *	6/2004	Walters	.....	D6/474
D502,609 S *	3/2005	Tonin	.....	D6/354

\* cited by examiner

*Primary Examiner*—Caron Veynar

*Assistant Examiner*—Abraham Bahta

(74) *Attorney, Agent, or Firm*—Nixon & Vanderhye P.C.

(57) **CLAIM**

The ornamental design for a “display stand for model airplane,” as shown and described.

**DESCRIPTION**

This application is related to commonly owned copending U.S. Appl. Ser. No. 29/274,881 filed even date herewith, the entire content of which is expressly incorporated herein by reference.

FIG. 1 is a rear perspective view of a display stand for model airplane which embodies my new and original design therefore, the dashed line therein representing structures in the environment of the claimed design but forming no part of the claimed design;

FIG. 2 is a top plan thereof;

FIG. 3 is right side elevation view thereof;

FIG. 4 is a left side elevation view thereof;

FIG. 5 is front elevation view thereof;

FIG. 6 is a rear elevation view thereof; and,

FIG. 7 is a bottom plan view thereof.

The broken lines shown in FIG. 7 are for illustrative purposes only and form no part of the claimed design.

**1 Claim, 5 Drawing Sheets**

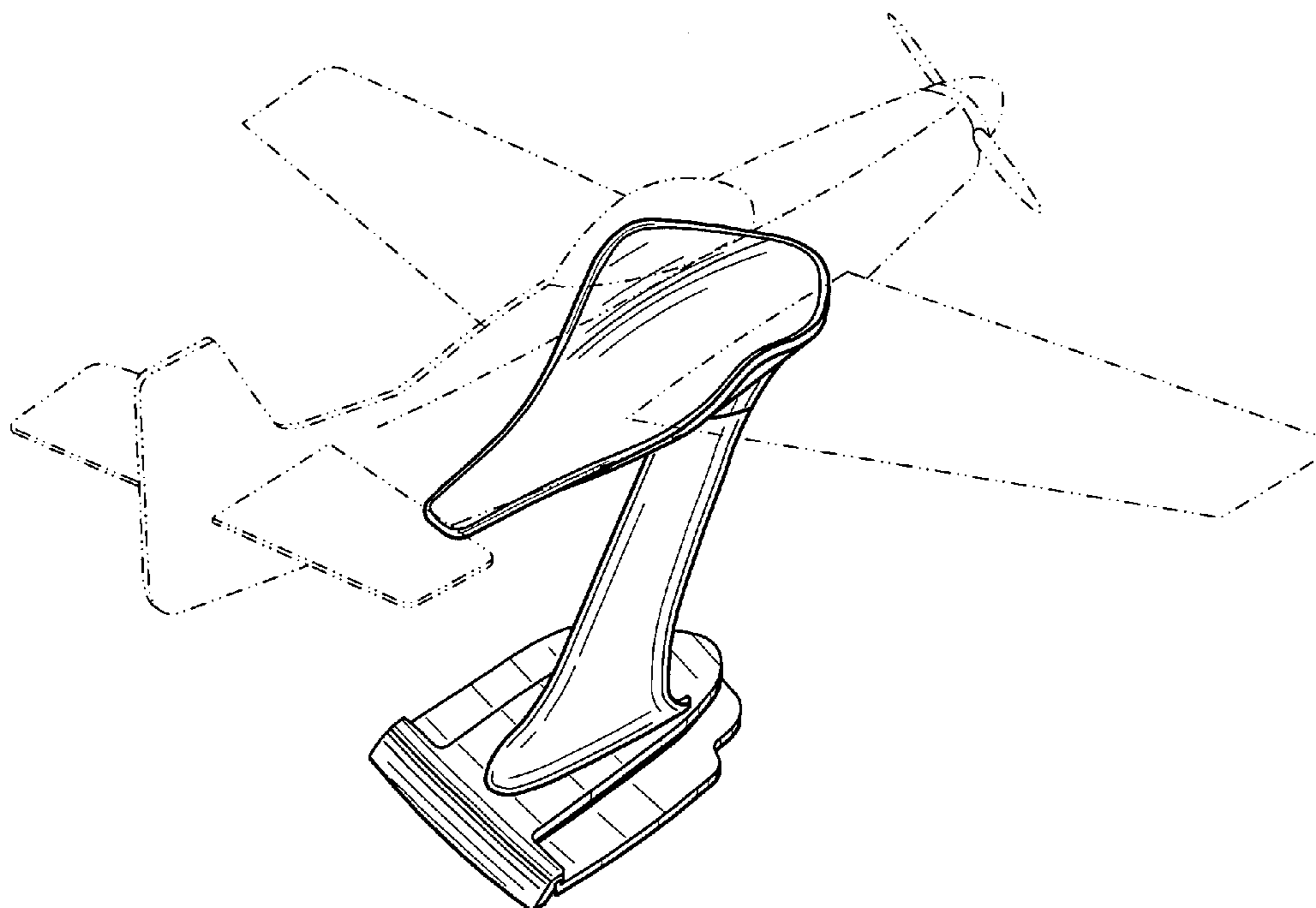

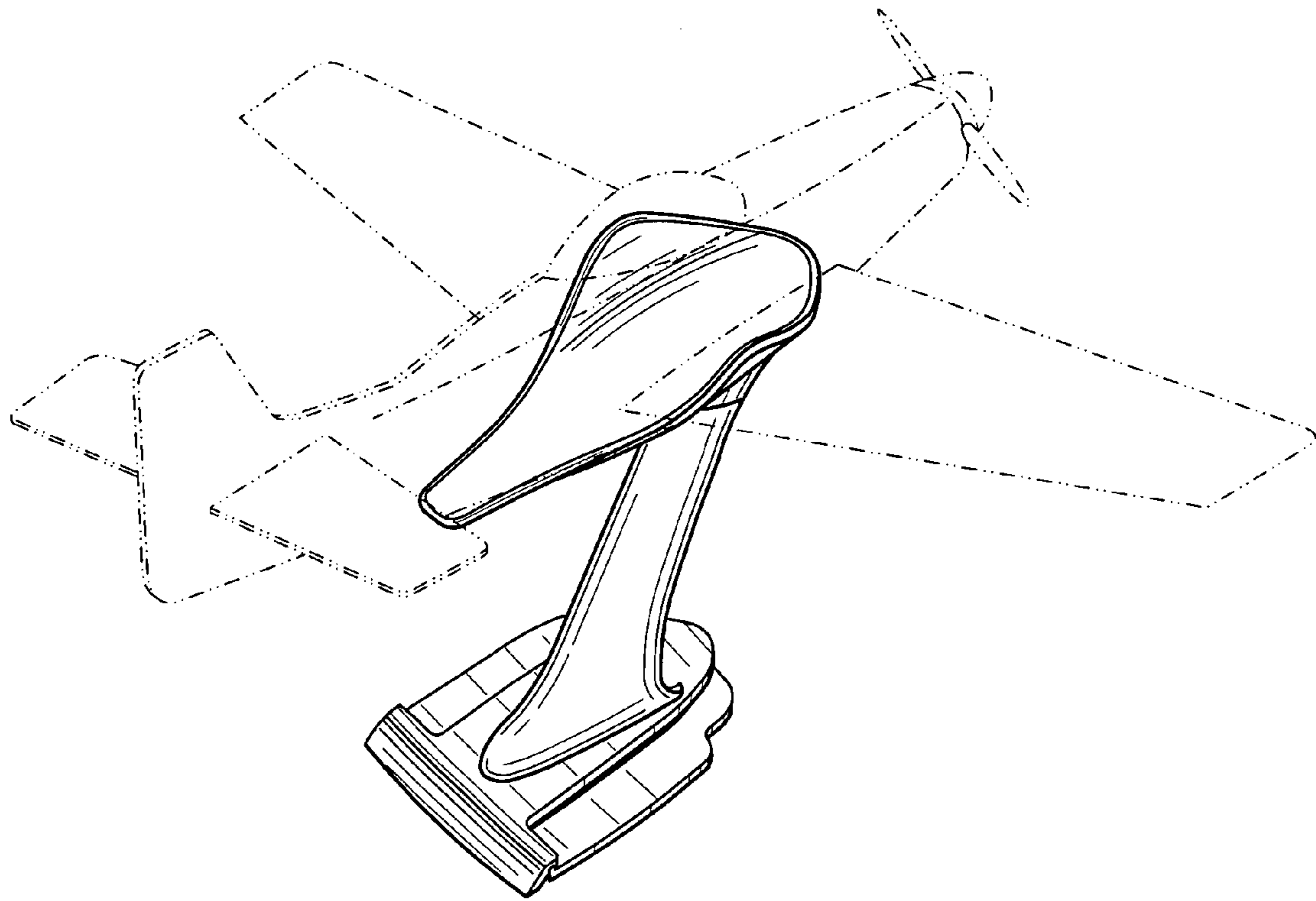
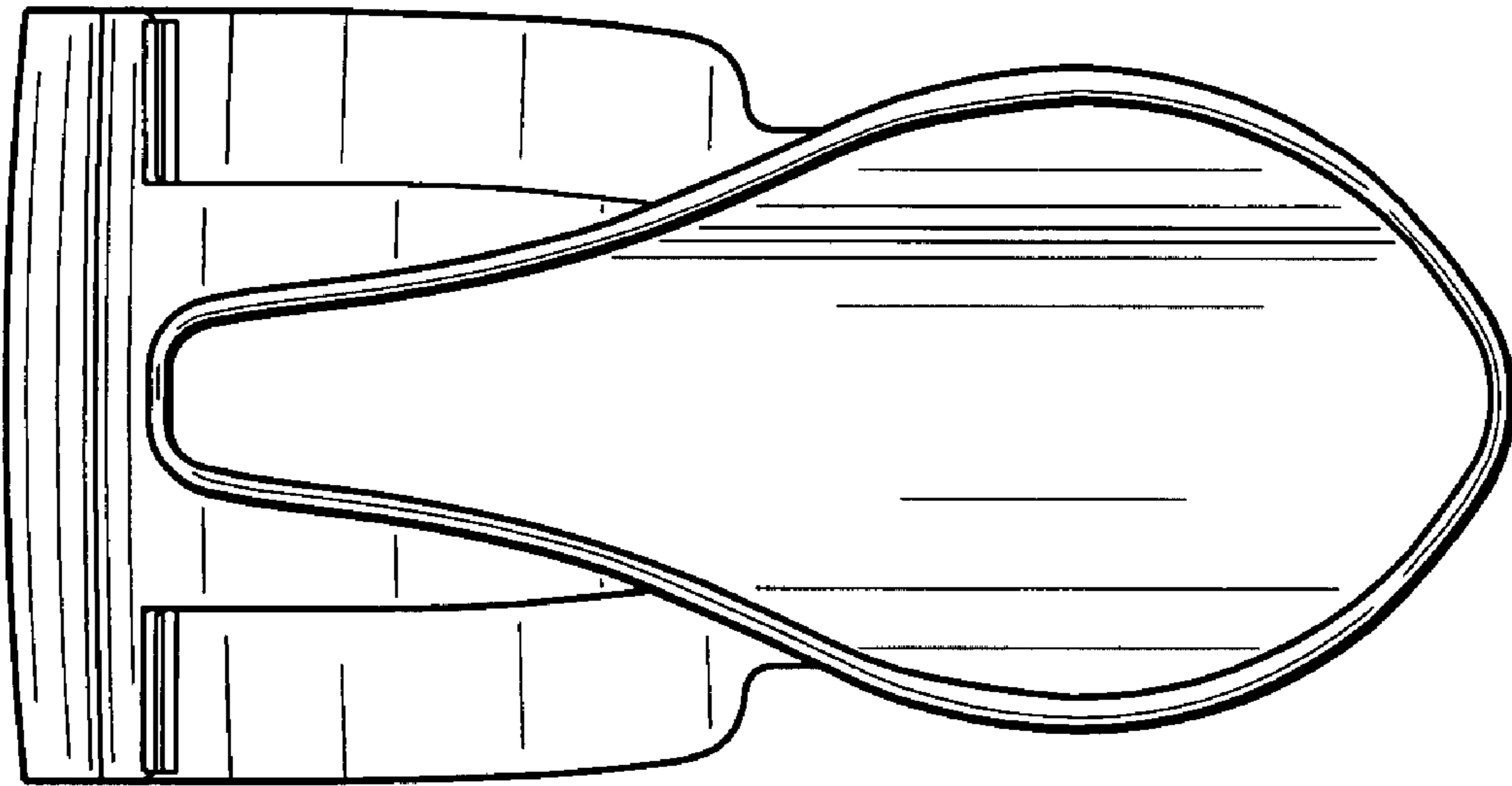

FIG. 1



**FIG. 2**

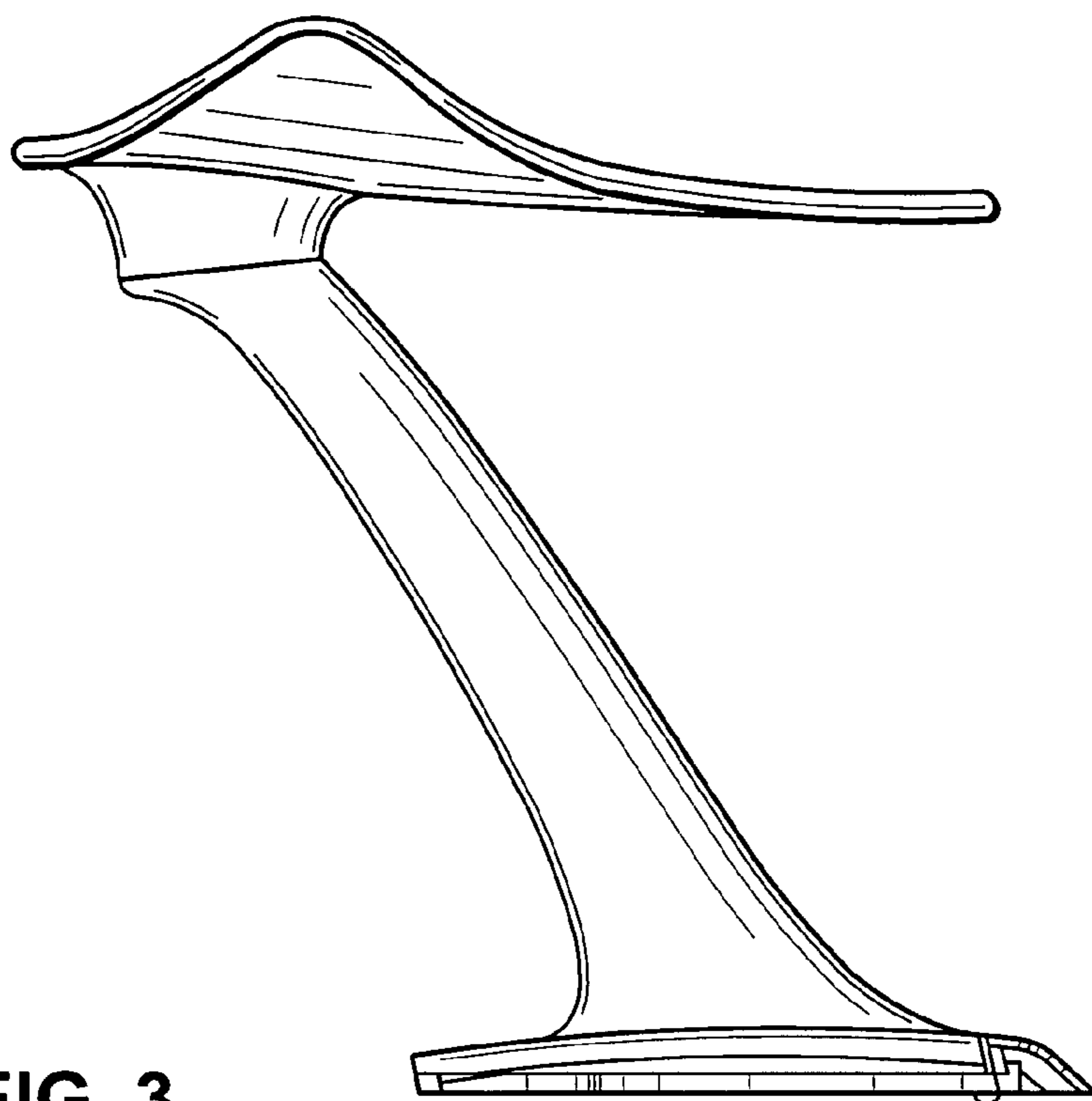

FIG. 3

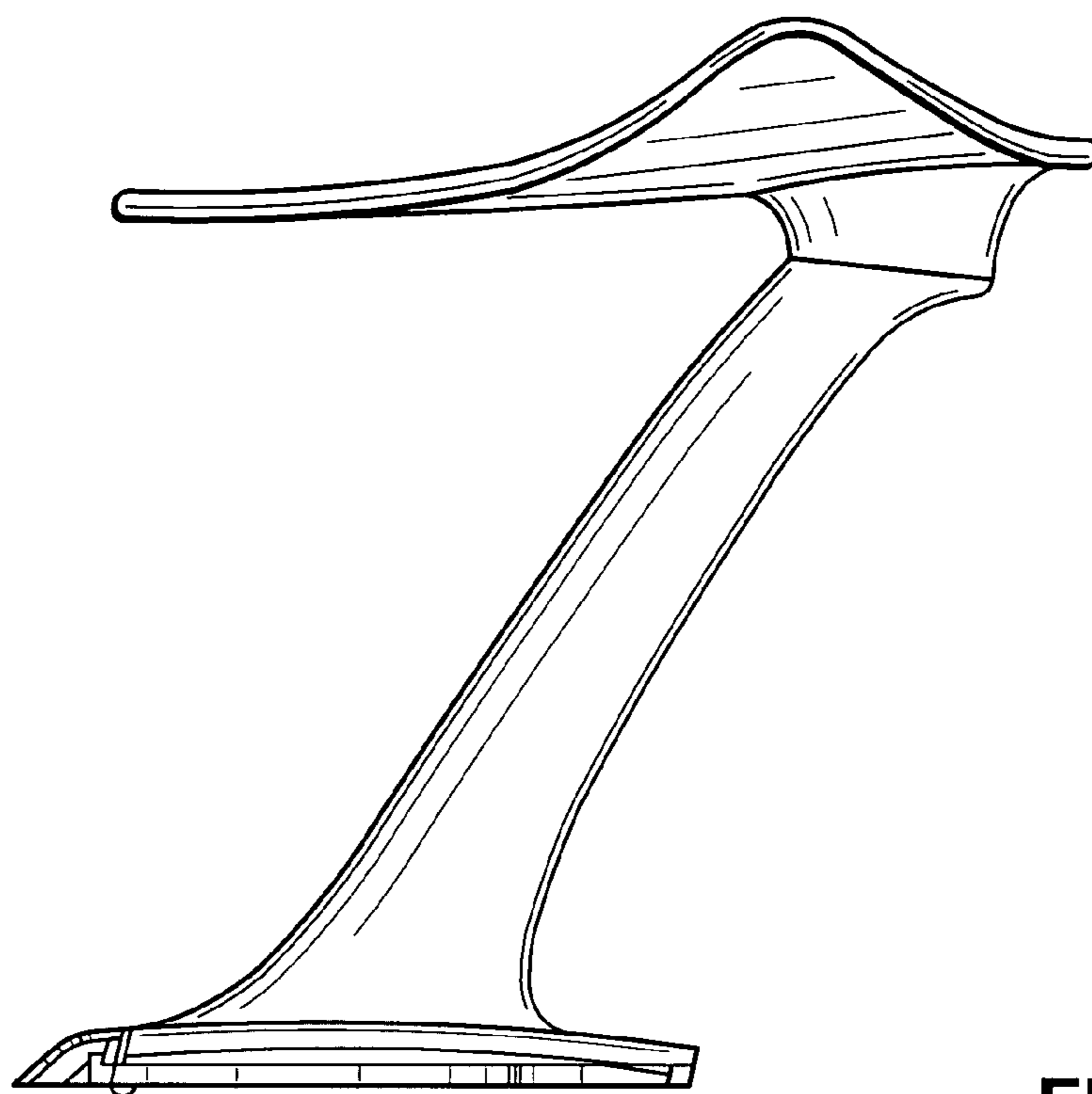

FIG. 4

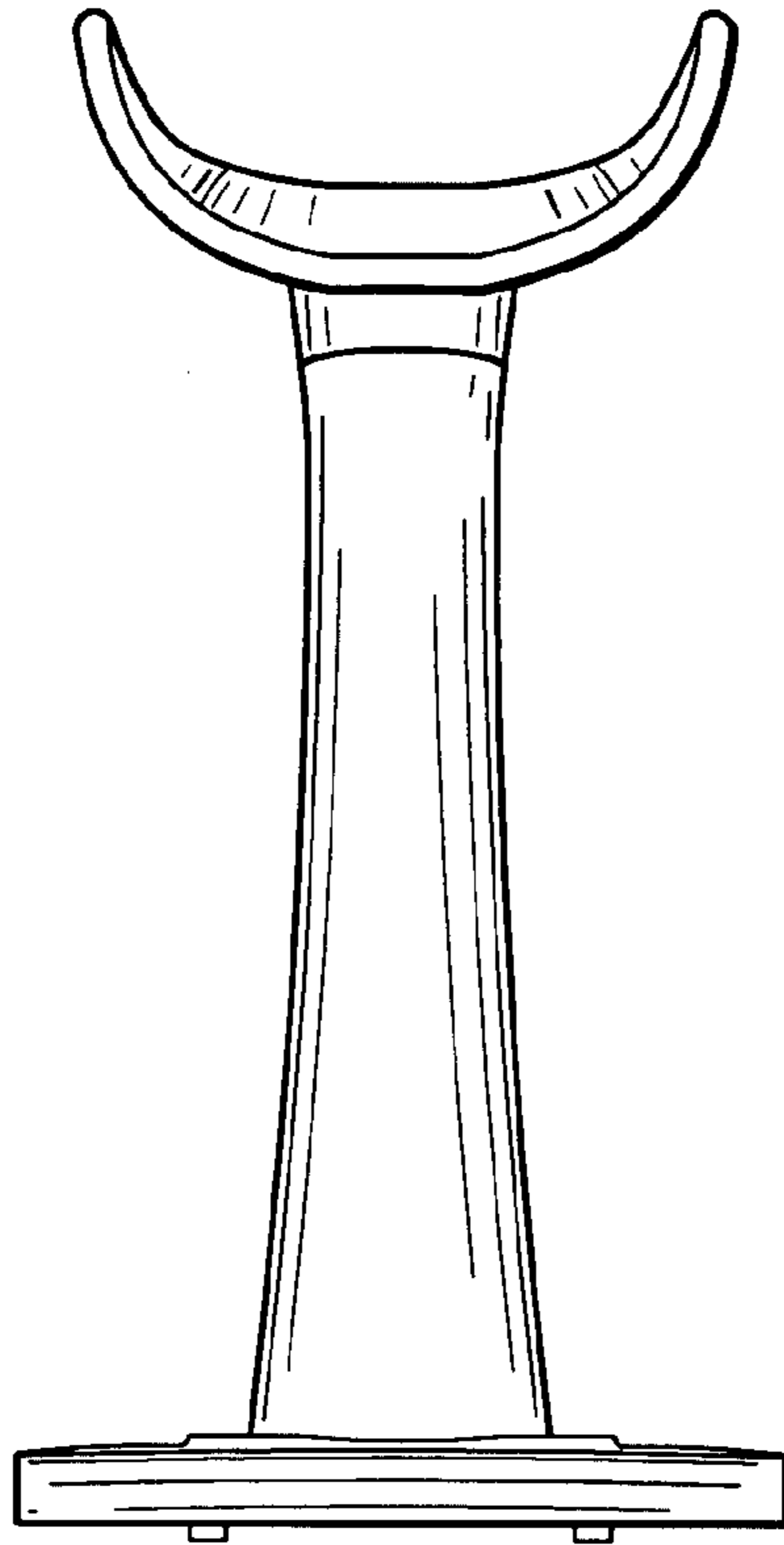

FIG. 5

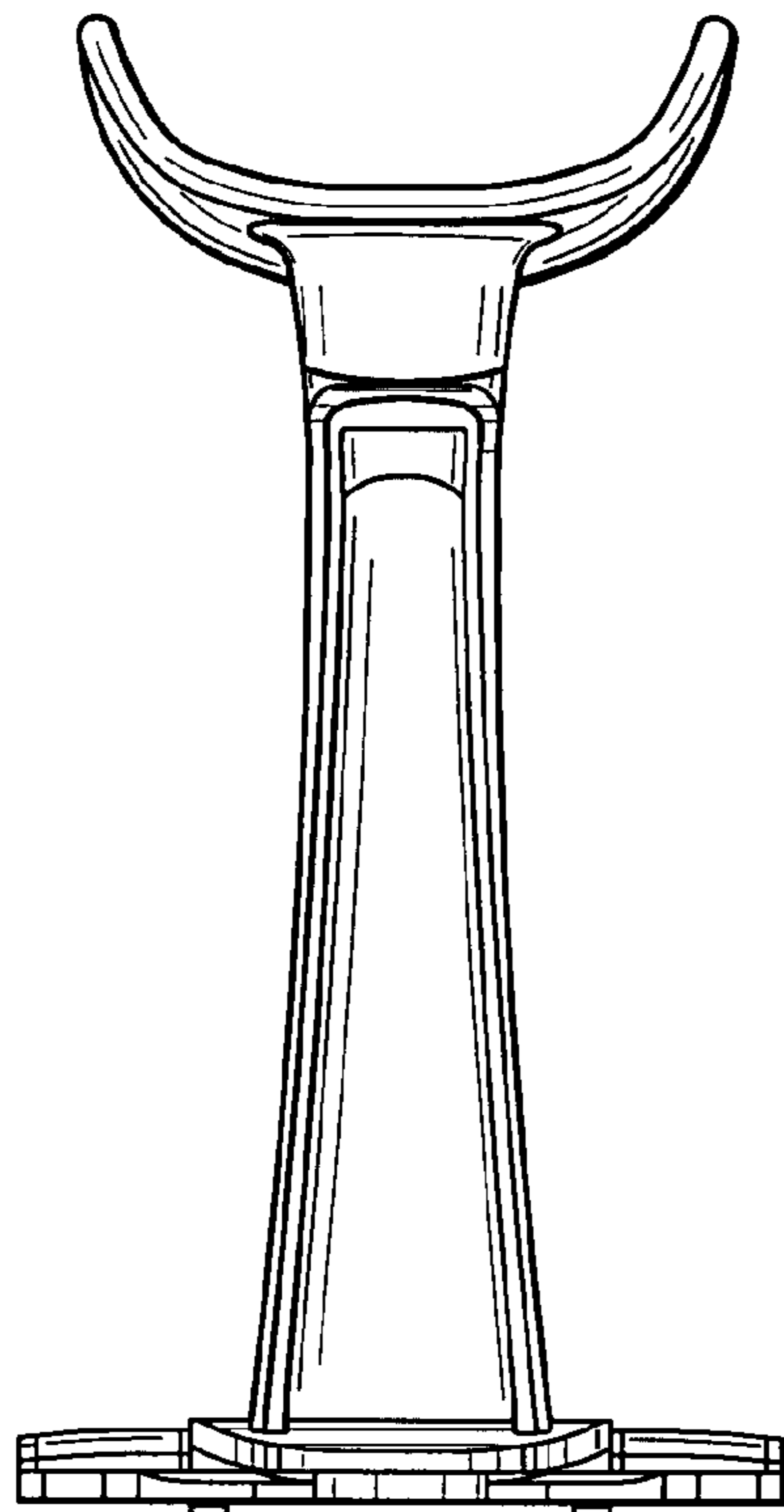
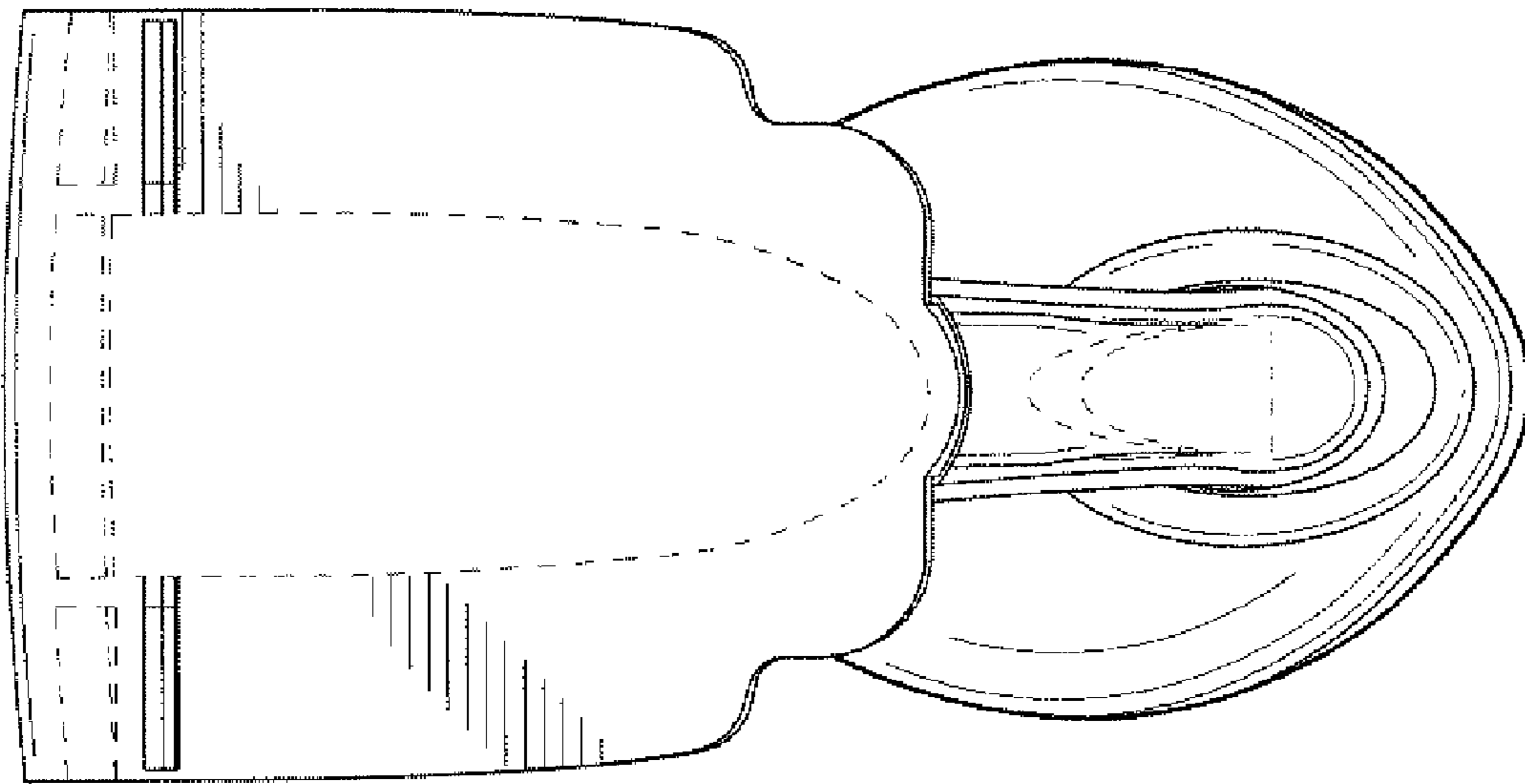

FIG. 6



**FIG. 7**