



US00D585353S

(12) **United States Design Patent**
Scheu

(10) **Patent No.:** **US D585,353 S**
(45) **Date of Patent:** **** Jan. 27, 2009**

(54) **FRONT FACE OF A VEHICLE WHEEL**

(75) Inventor: **Armin Scheu**, Stuttgart (DE)

(73) Assignee: **Daimler AG**, Stuttgart (DE)

(**) Term: **14 Years**

(21) Appl. No.: **29/290,713**

(22) Filed: **Jan. 4, 2008**

(30) **Foreign Application Priority Data**

Jul. 5, 2007 (EM) 000752571-0001

(51) **LOC (9) Cl.** **12-16**

(52) **U.S. Cl.** **D12/211**

(58) **Field of Classification Search** D12/204-213;
301/37.101, 64.101, 65, 64.201

See application file for complete search history.

(56) **References Cited**

U.S. PATENT DOCUMENTS

D428,380 S * 7/2000 Chinellato D12/211
D474,440 S * 5/2003 Oh D12/211
D480,036 S * 9/2003 Laengerer D12/211
D486,111 S * 2/2004 Weidhase D12/211

D506,172 S * 6/2005 Pfeiffer D12/211
D515,494 S * 2/2006 Laengerer D12/211
D516,990 S * 3/2006 Schweizer D12/211
D520,437 S * 5/2006 Scheu D12/211
D549,635 S * 8/2007 Hernandez D12/211

* cited by examiner

Primary Examiner—Stacia Cadmus

(74) *Attorney, Agent, or Firm*—Crowell & Moring LLP

(57) **CLAIM**

The ornamental design for a front face of a vehicle wheel, as shown and described.

DESCRIPTION

FIG. 1 is a front view of a first embodiment of a front face of a vehicle wheel according to my novel design; and

FIG. 2 is a perspective view thereof.

FIG. 3 is a front view of a second embodiment of the front face of a vehicle wheel according to my novel design; and,

FIG. 4 is a perspective view thereof.

The broken line showing of the bolt holes and center cap in the central hub area is included for the purpose of illustrating environment and forms no part of the claimed design.

1 Claim, 2 Drawing Sheets

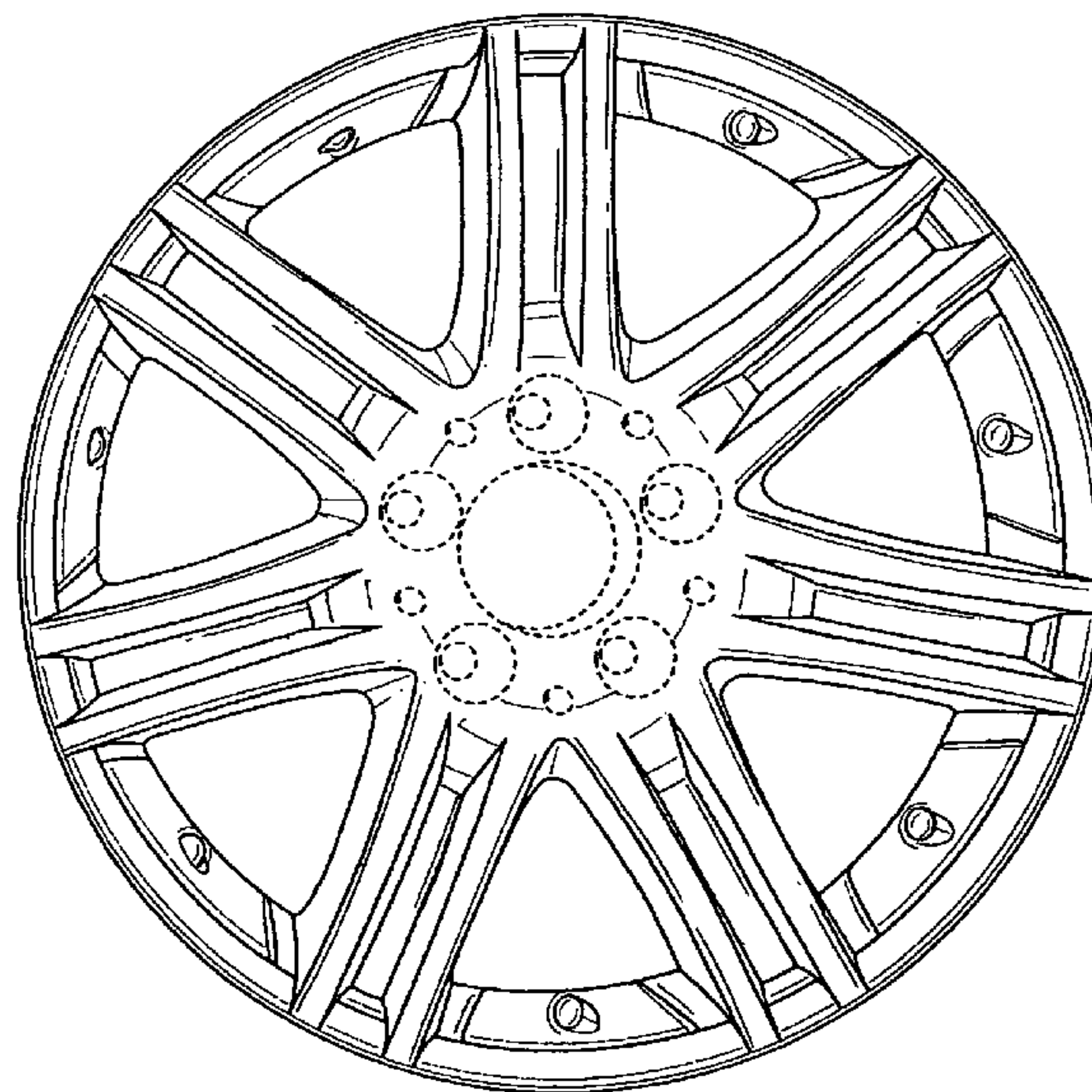
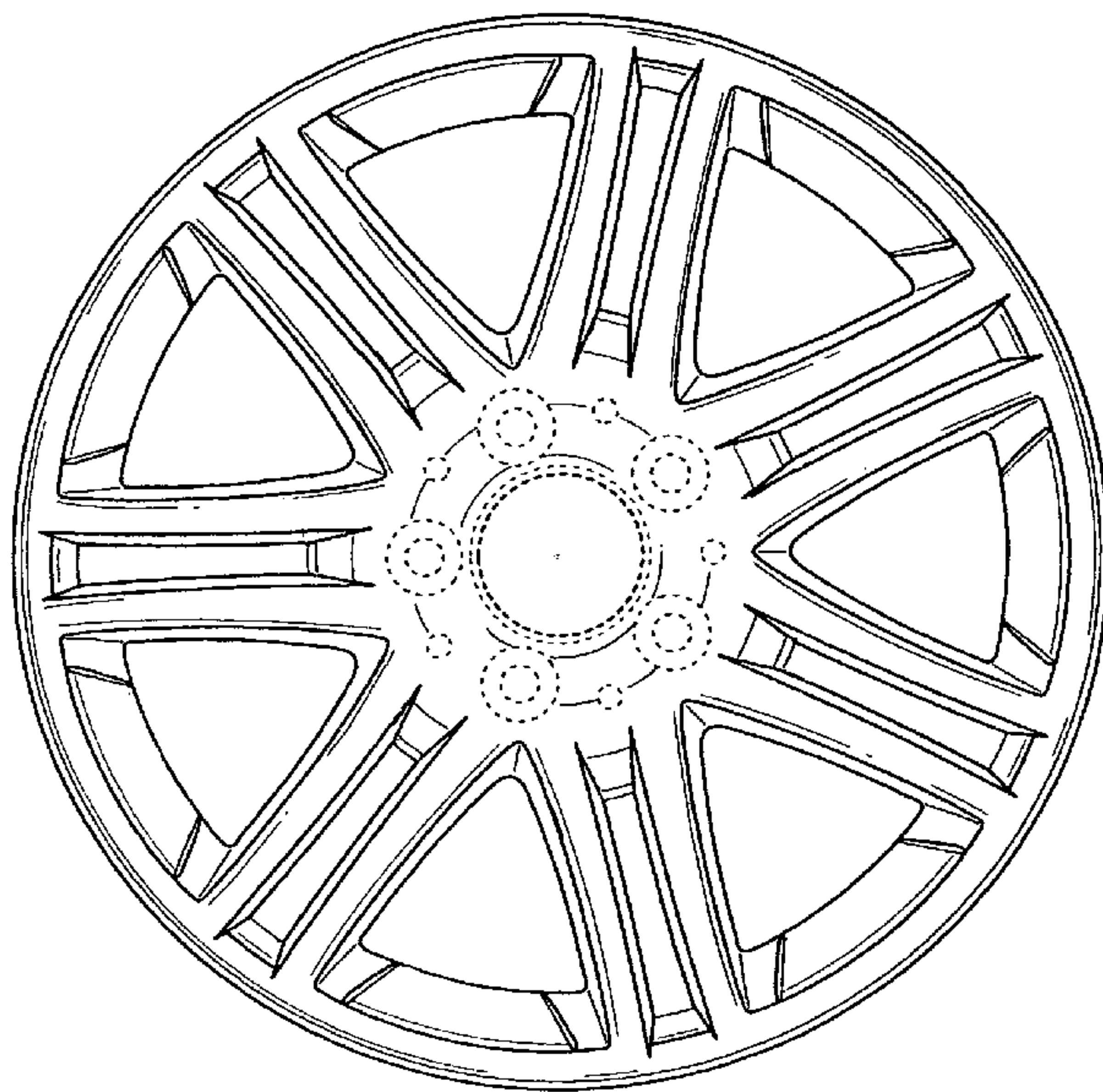

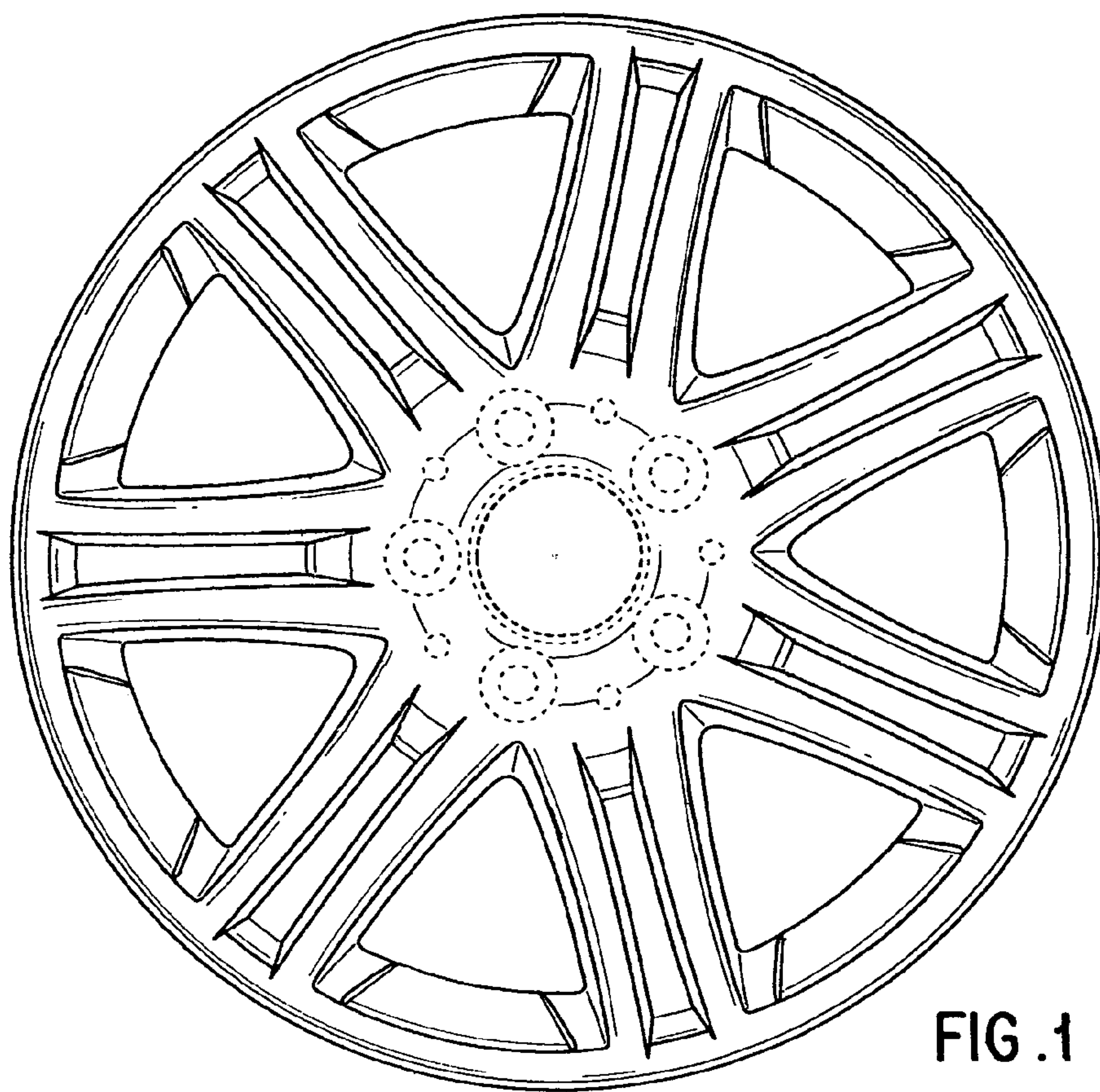

FIG. 1

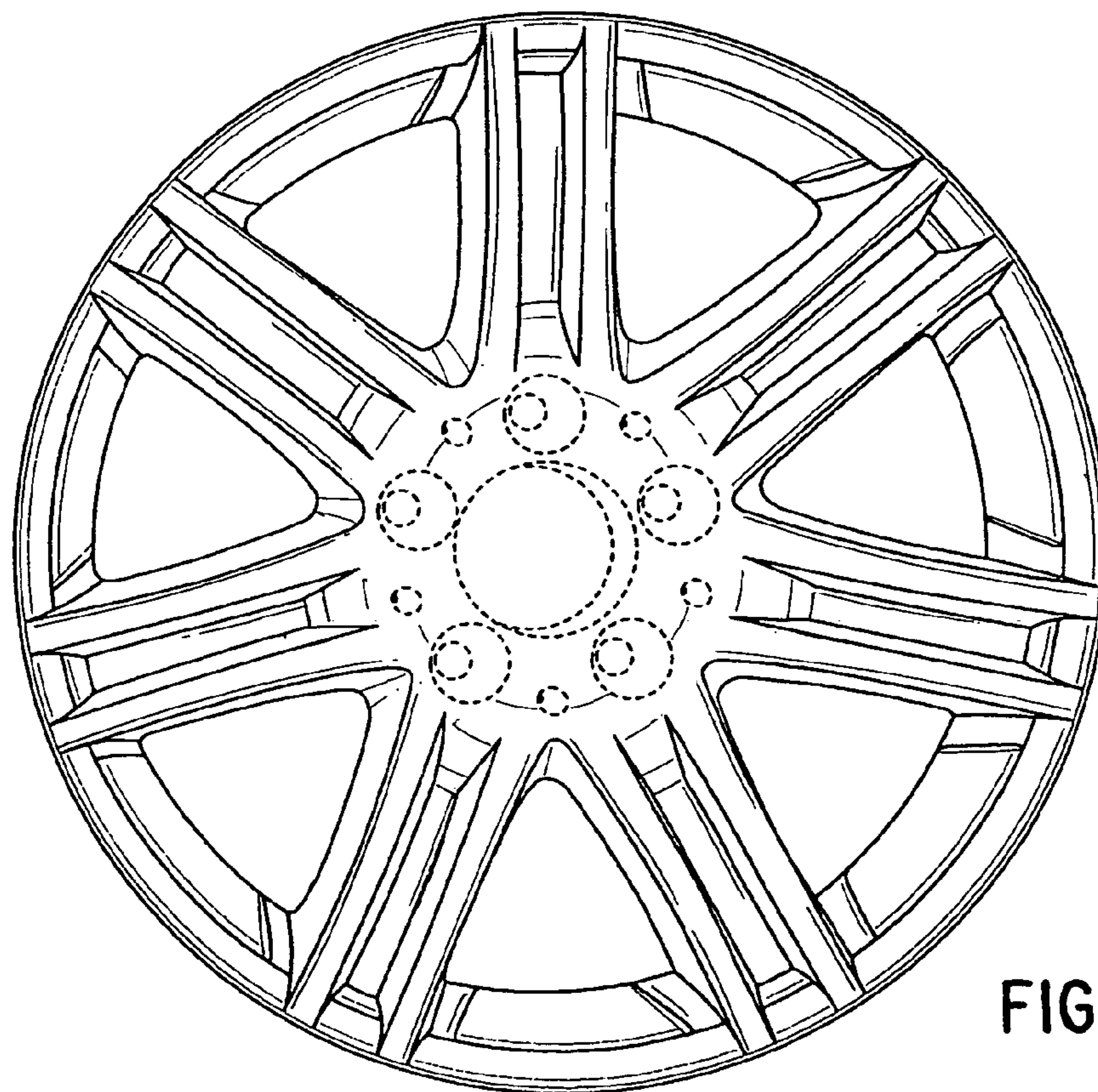

FIG. 2

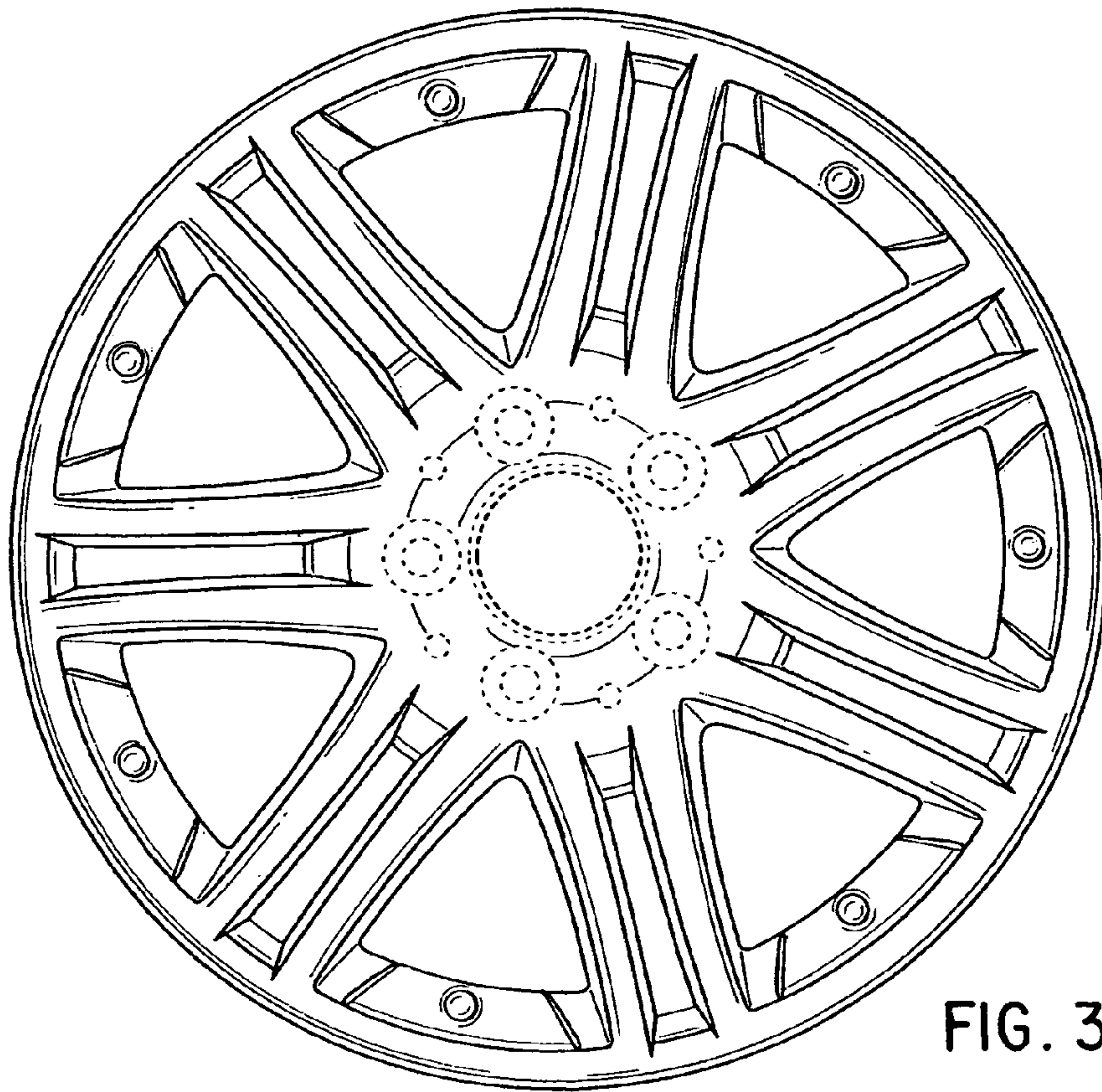

FIG. 3

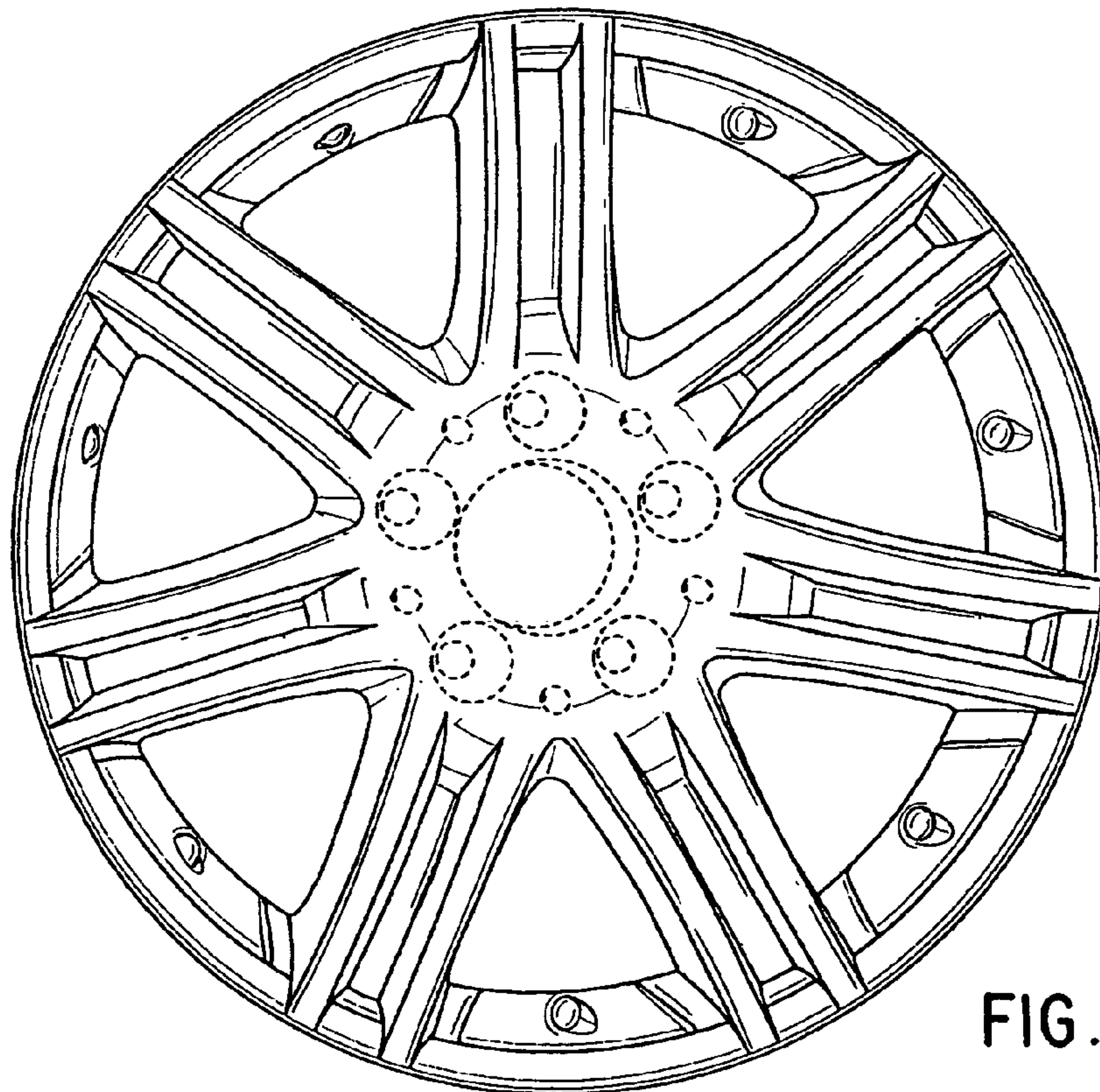

FIG. 4