



US00D585351S

(12) **United States Design Patent**  
**Hieke**

(10) **Patent No.:** **US D585,351 S**  
(45) **Date of Patent:** **\*\* Jan. 27, 2009**

(54) **FRONT FACE OF A VEHICLE WHEEL**

(75) Inventor: **Claus Hieke**, Sindelfingen (DE)

(73) Assignee: **Daimler AG**, Stuttgart (DE)

(\*\*) Term: **14 Years**

(21) Appl. No.: **29/268,807**

(22) Filed: **Nov. 14, 2006**

(30) **Foreign Application Priority Data**

May 15, 2006 (EM) ..... 000529185-0013  
May 15, 2006 (EM) ..... 000529185-0014

(51) **LOC (9) Cl.** ..... **12-16**

(52) **U.S. Cl.** ..... **D12/209**

(58) **Field of Classification Search** ..... D12/204-213;  
301/37.101, 64.101, 65, 64.201  
See application file for complete search history.

(56) **References Cited**

**U.S. PATENT DOCUMENTS**

D206,432 S \* 12/1966 Reid ..... D12/209  
D375,073 S \* 10/1996 Theiss ..... D12/209  
D377,471 S \* 1/1997 Stach ..... D12/209  
D401,205 S \* 11/1998 Fischer ..... D12/209  
D430,523 S \* 9/2000 Pfeiffer ..... D12/209  
D452,838 S \* 1/2002 Hieke ..... D12/209  
D453,131 S \* 1/2002 Gabath ..... D12/209  
D454,530 S \* 3/2002 Hieke ..... D12/211  
D461,756 S \* 8/2002 Hieke ..... D12/211  
D462,309 S \* 9/2002 Hieke ..... D12/211  
D486,437 S \* 2/2004 Hieke ..... D12/211  
D487,418 S \* 3/2004 Hieke ..... D12/211  
D495,985 S \* 9/2004 Lai ..... D12/209  
D497,339 S \* 10/2004 Heinrich ..... D12/209  
D504,649 S \* 5/2005 Pfeiffer ..... D12/209  
D514,495 S 2/2006 Hieke

D515,996 S \* 2/2006 Baumgartner ..... D12/209  
D519,902 S \* 5/2006 Pfeiffer ..... D12/209  
D522,431 S \* 6/2006 Hieke ..... D12/209  
D525,928 S \* 8/2006 Pfeiffer ..... D12/209  
D528,059 S 9/2006 Hieke  
D532,733 S \* 11/2006 Hieke ..... D12/209  
D532,734 S \* 11/2006 Hieke ..... D12/209  
D537,027 S \* 2/2007 Hieke ..... D12/211  
D542,211 S \* 5/2007 Hieke ..... D12/211  
D542,726 S \* 5/2007 Hieke ..... D12/209  
D542,729 S \* 5/2007 Hieke ..... D12/211  
D551,147 S \* 9/2007 Guevara ..... D12/209  
D572,646 S \* 7/2008 Hieke ..... D12/209  
D578,949 S \* 10/2008 Hieke ..... D12/211  
D579,847 S \* 11/2008 Hieke ..... D12/211

**FOREIGN PATENT DOCUMENTS**

DE 40403902.2 7/2004

\* cited by examiner

*Primary Examiner*—Cathron C Brooks

*Assistant Examiner*—Austin Murphy

(74) *Attorney, Agent, or Firm*—Crowell & Moring LLP

(57) **CLAIM**

The ornamental design for a front face of a vehicle wheel, as shown and described.

**DESCRIPTION**

FIG. 1 is a front view of a first embodiment of a front face of a vehicle wheel according to my design; and

FIG. 2 is a perspective view thereof.

FIG. 3 is a front view of a second embodiment of the front face of a vehicle wheel according to my novel design; and,

FIG. 4 is a perspective view thereof.

The broken lines are for illustrative purposes only and form no part of the claimed design.

**1 Claim, 2 Drawing Sheets**

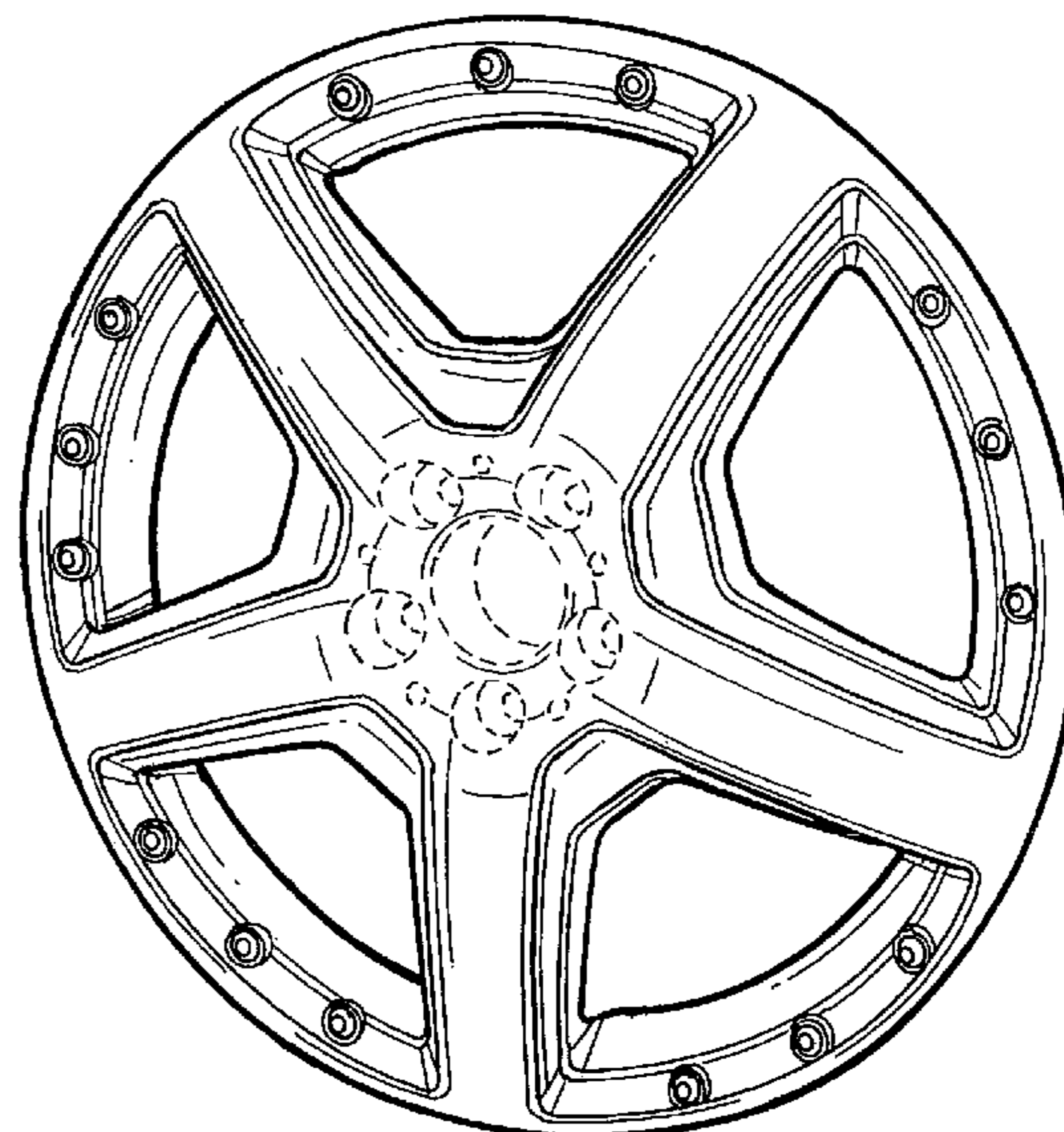
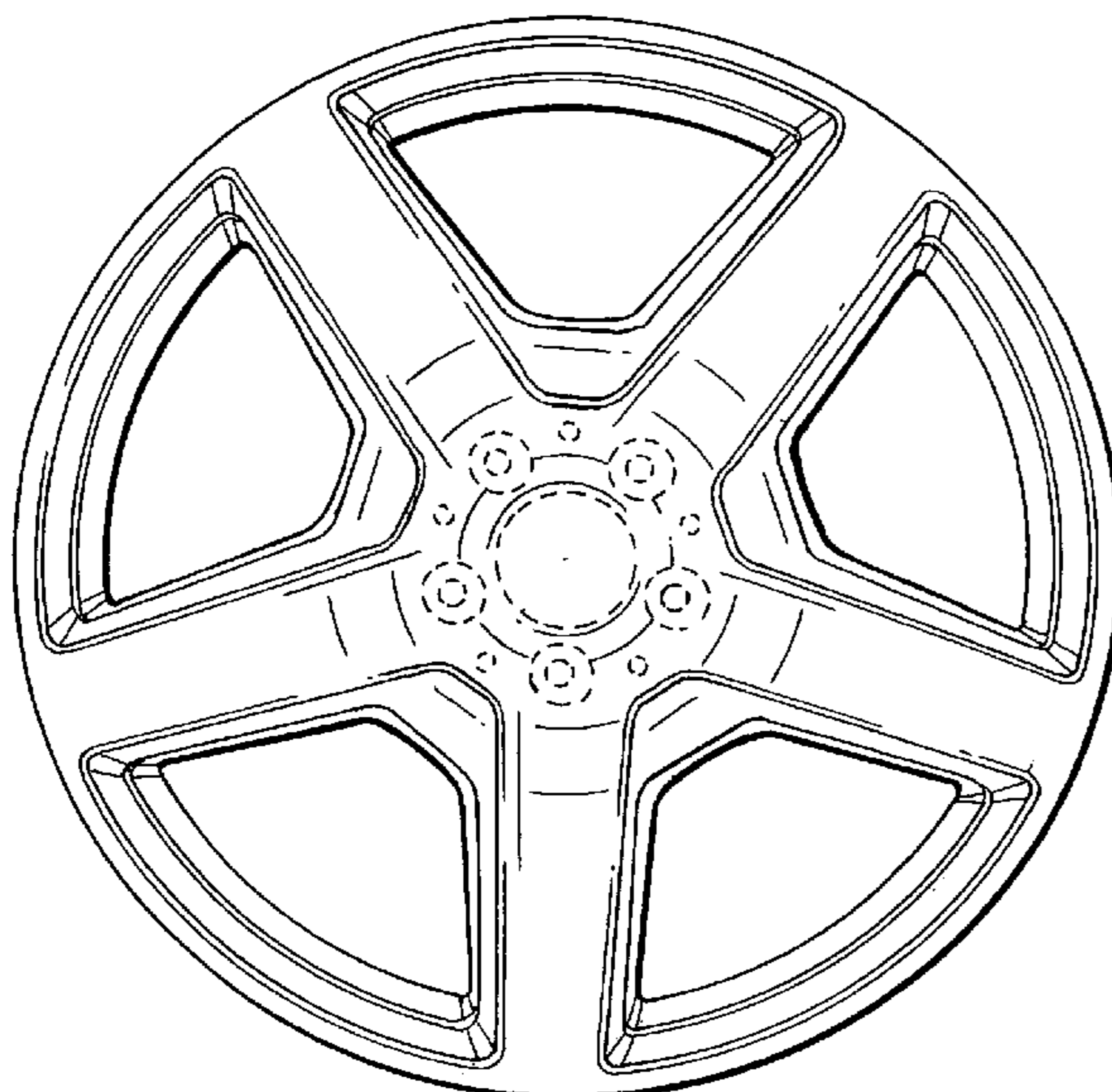

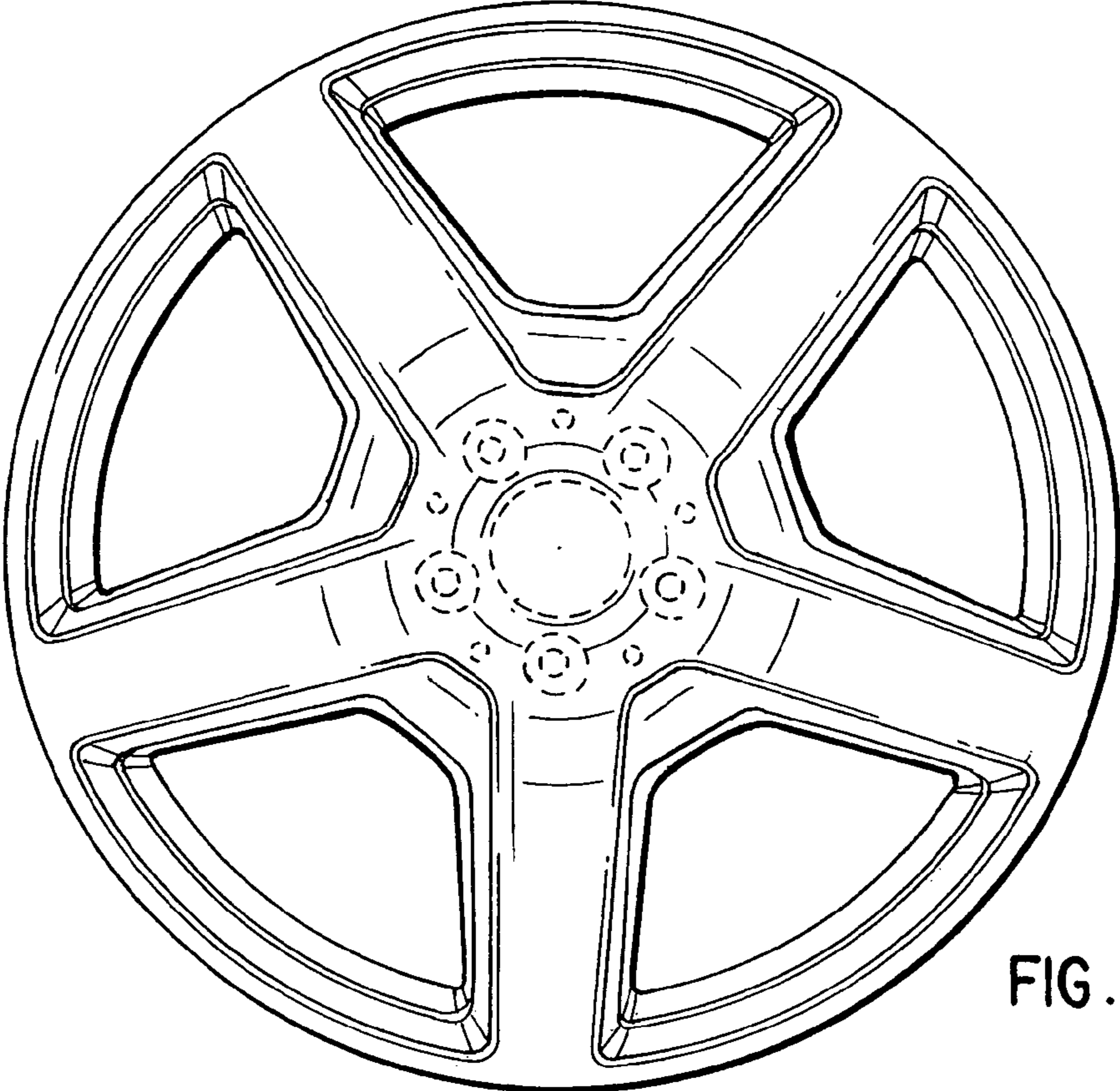

FIG. 1

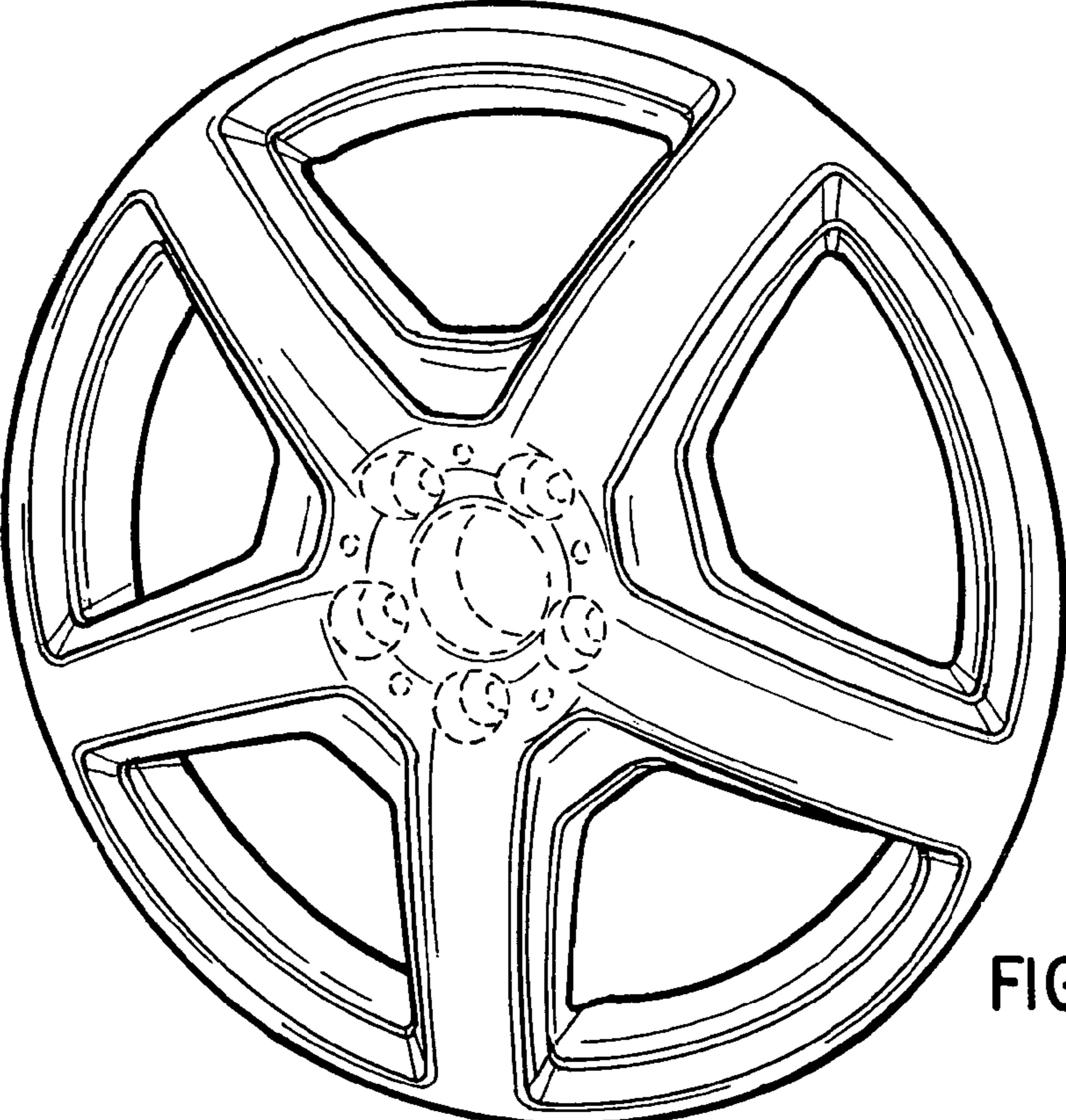

FIG. 2

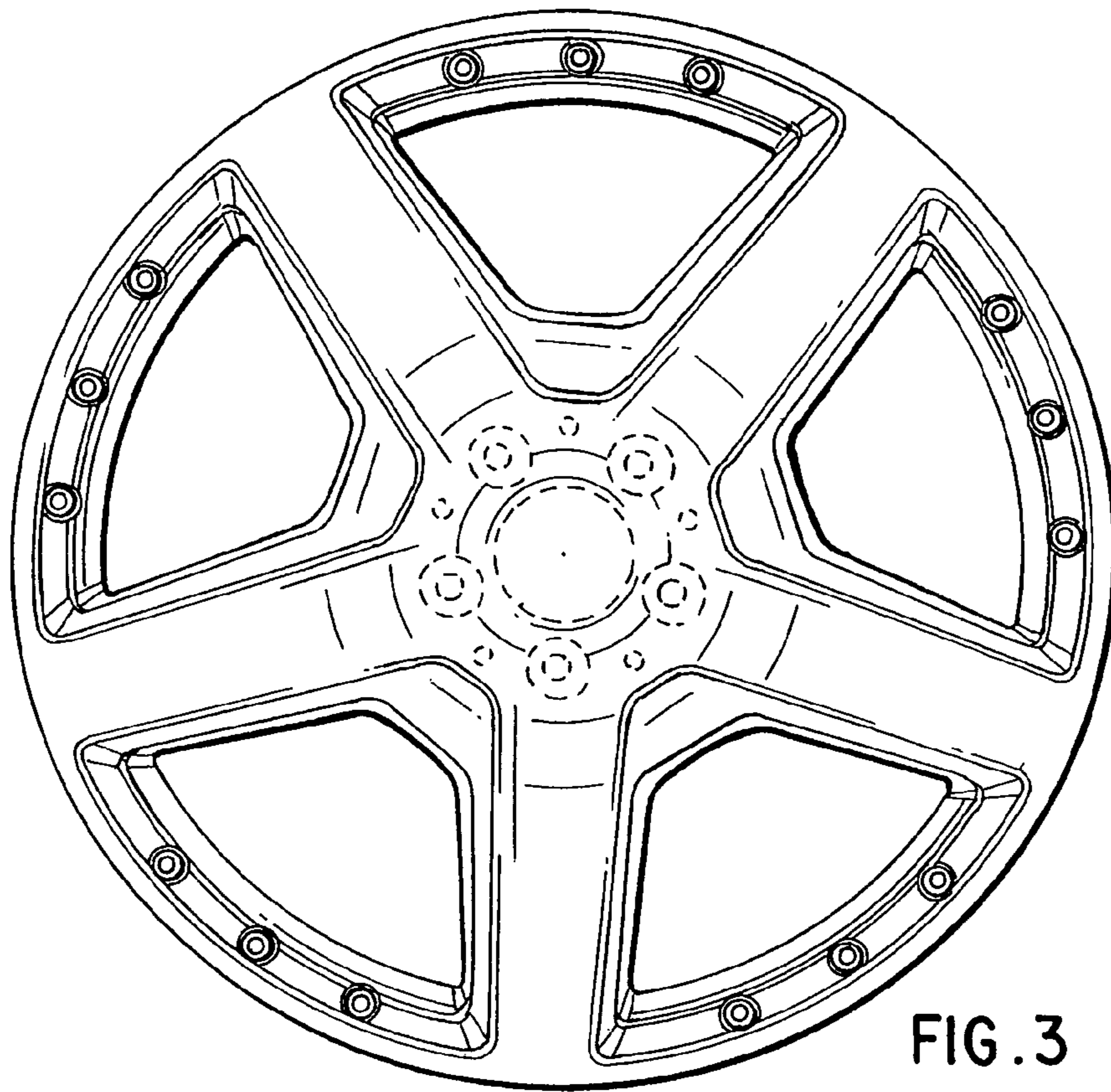

FIG. 3

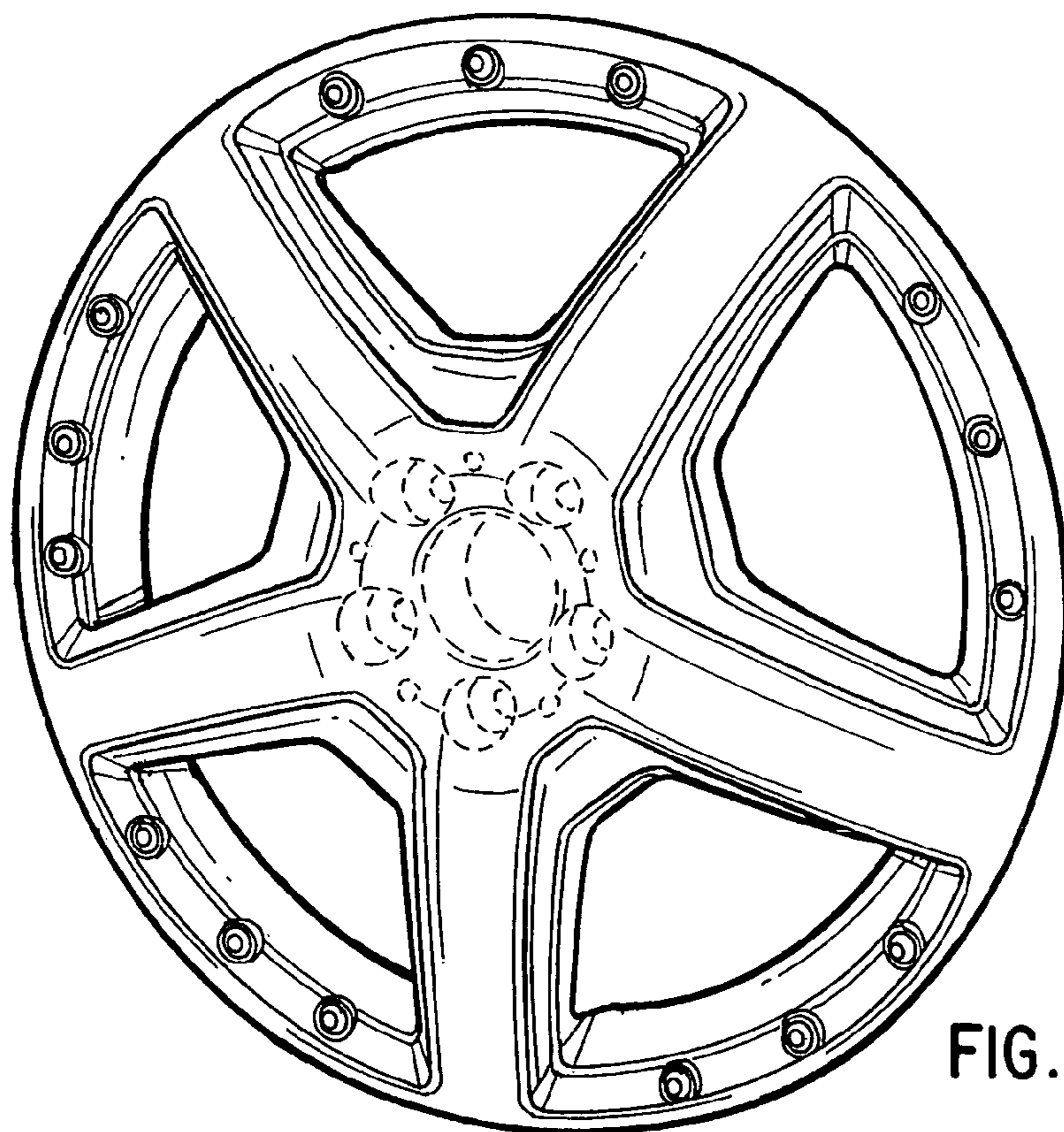

FIG. 4