



US00D585334S

(12) **United States Design Patent**
Chiu et al.

(10) **Patent No.:** **US D585,334 S**

(45) **Date of Patent:** **** Jan. 27, 2009**

(54) **MOTORCYCLE**

(75) Inventors: **Chi-Hsien Chiu**, Kaohsiung (TW);
Han-Pin Tsai, Kaohsiung (TW)

(73) Assignee: **Kwang Yang Motor Co., Ltd.**,
Kaohsiung (TW)

(**) Term: **14 Years**

(21) Appl. No.: **29/299,387**

(22) Filed: **Dec. 26, 2007**

(51) **LOC (9) Cl.** **12-11**

(52) **U.S. Cl.** **D12/110**

(58) **Field of Classification Search** D12/110;
180/219

See application file for complete search history.

(56) **References Cited**

U.S. PATENT DOCUMENTS

D331,553 S	*	12/1992	Agnolucci	D12/110
D341,341 S	*	11/1993	Nakamura et al.	D12/110
D399,174 S	*	10/1998	Takeshita et al.	D12/110
D427,944 S	*	7/2000	Sakuma et al.	D12/110
D443,849 S	*	6/2001	Chen	D12/110

D557,638 S * 12/2007 Nakamura et al. D12/110

* cited by examiner

Primary Examiner—Cathron C Brooks

Assistant Examiner—Linda Brooks

(74) *Attorney, Agent, or Firm*—Nixon Peabody LLP

(57) **CLAIM**

The ornamental design for motorcycle, as shown and described.

DESCRIPTION

FIG. 1 is a perspective view of motorcycle showing our new design;

FIG. 2 is a front elevational view thereof;

FIG. 3 is a rear elevational view thereof;

FIG. 4 is a left side elevational view thereof;

FIG. 5 is a right side elevational view thereof;

FIG. 6 is a top plan view thereof; and,

FIG. 7 is a bottom plan view thereof.

The portions shown in broken lines do not form a part of the claimed design.

1 Claim, 7 Drawing Sheets

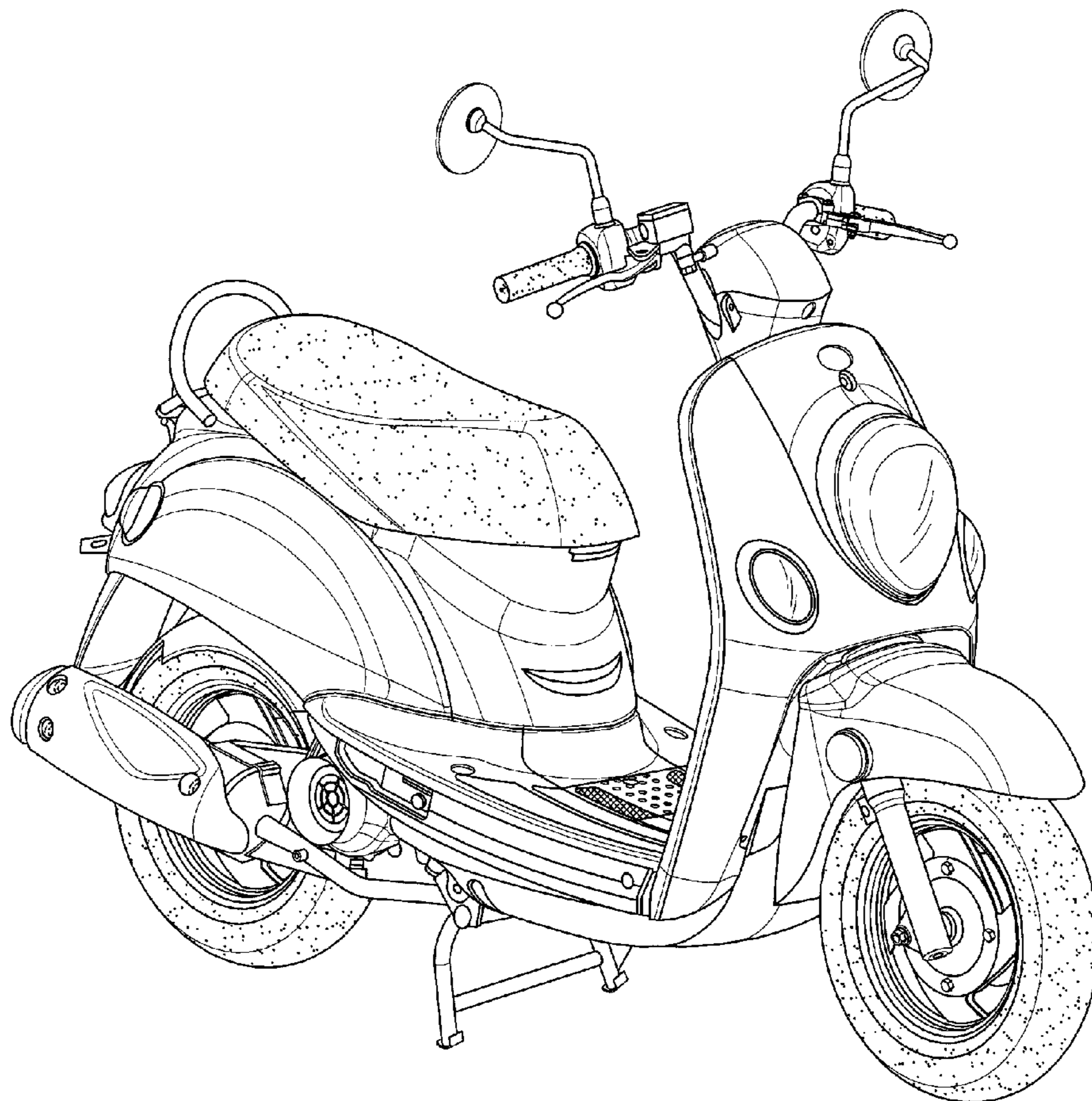

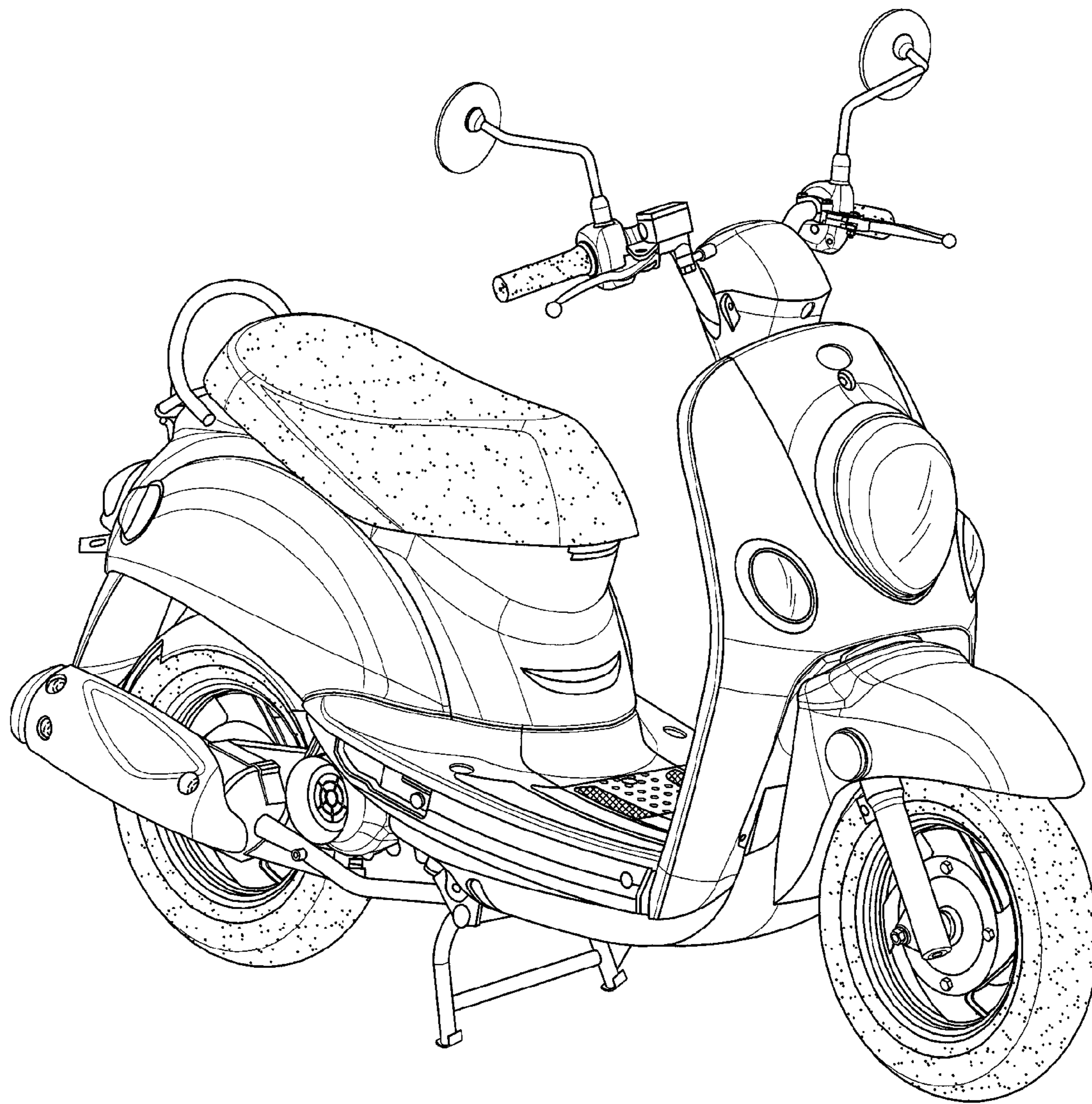

FIG. 1

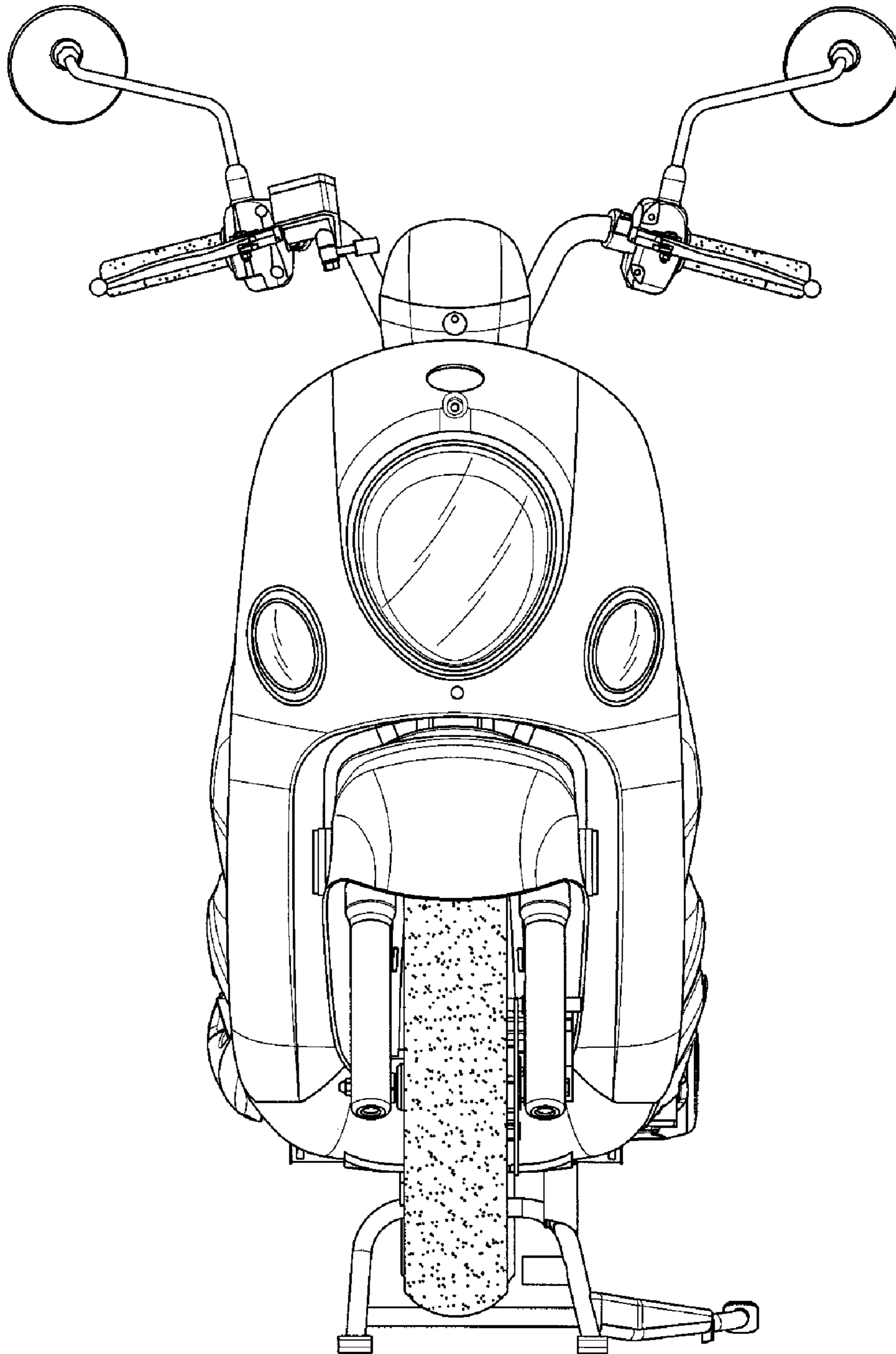

FIG. 2

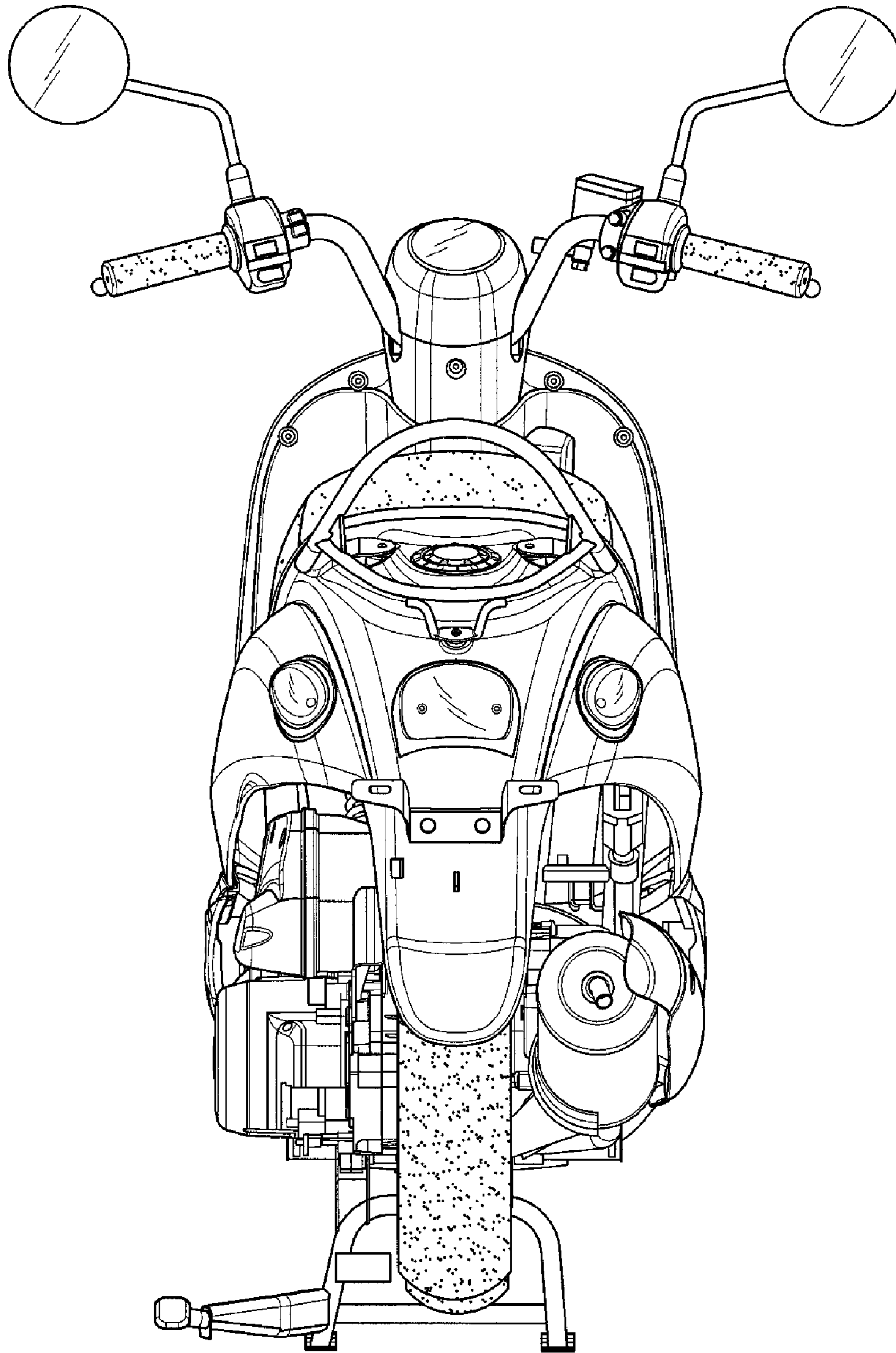

FIG. 3

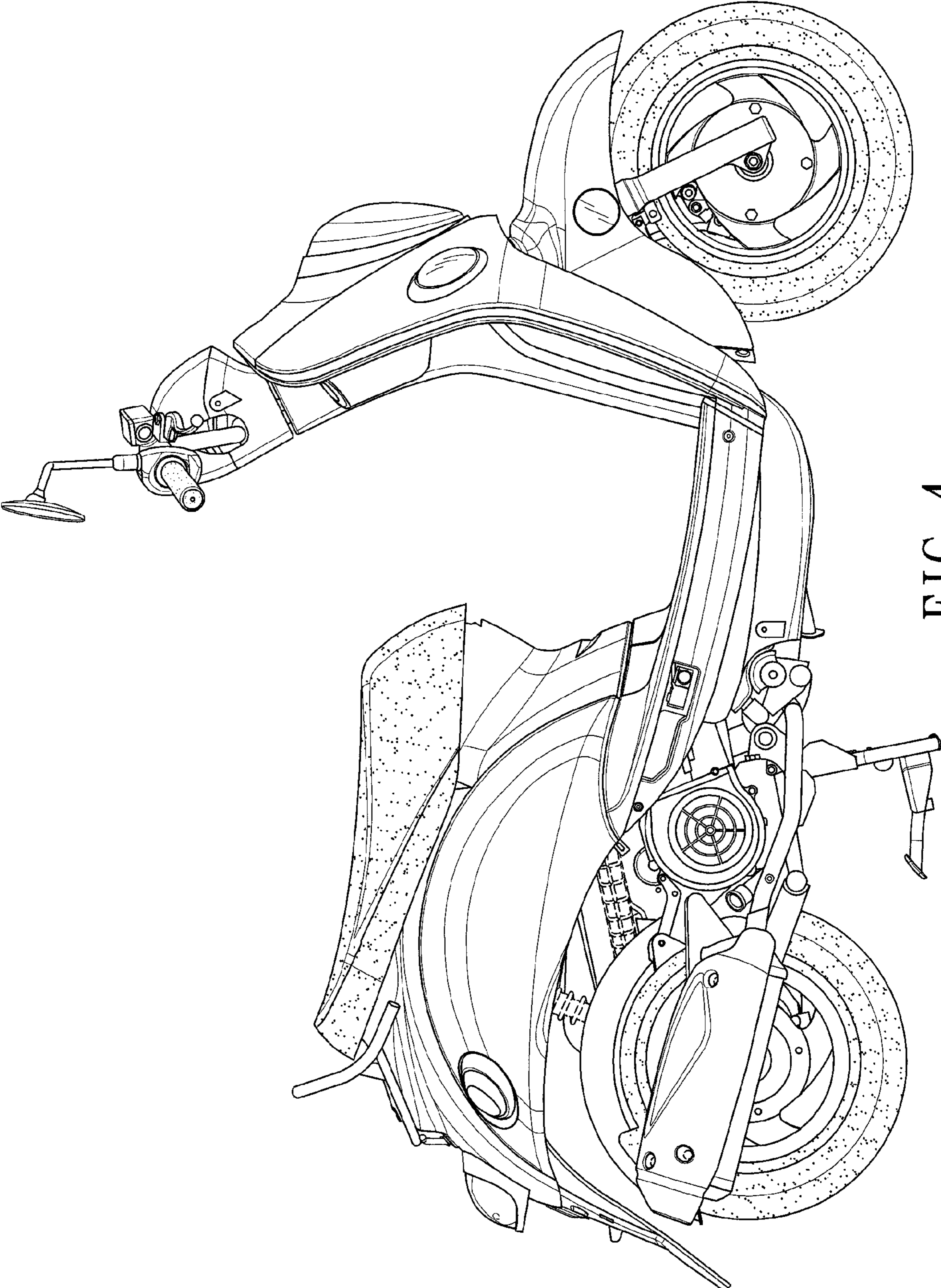

FIG. 4

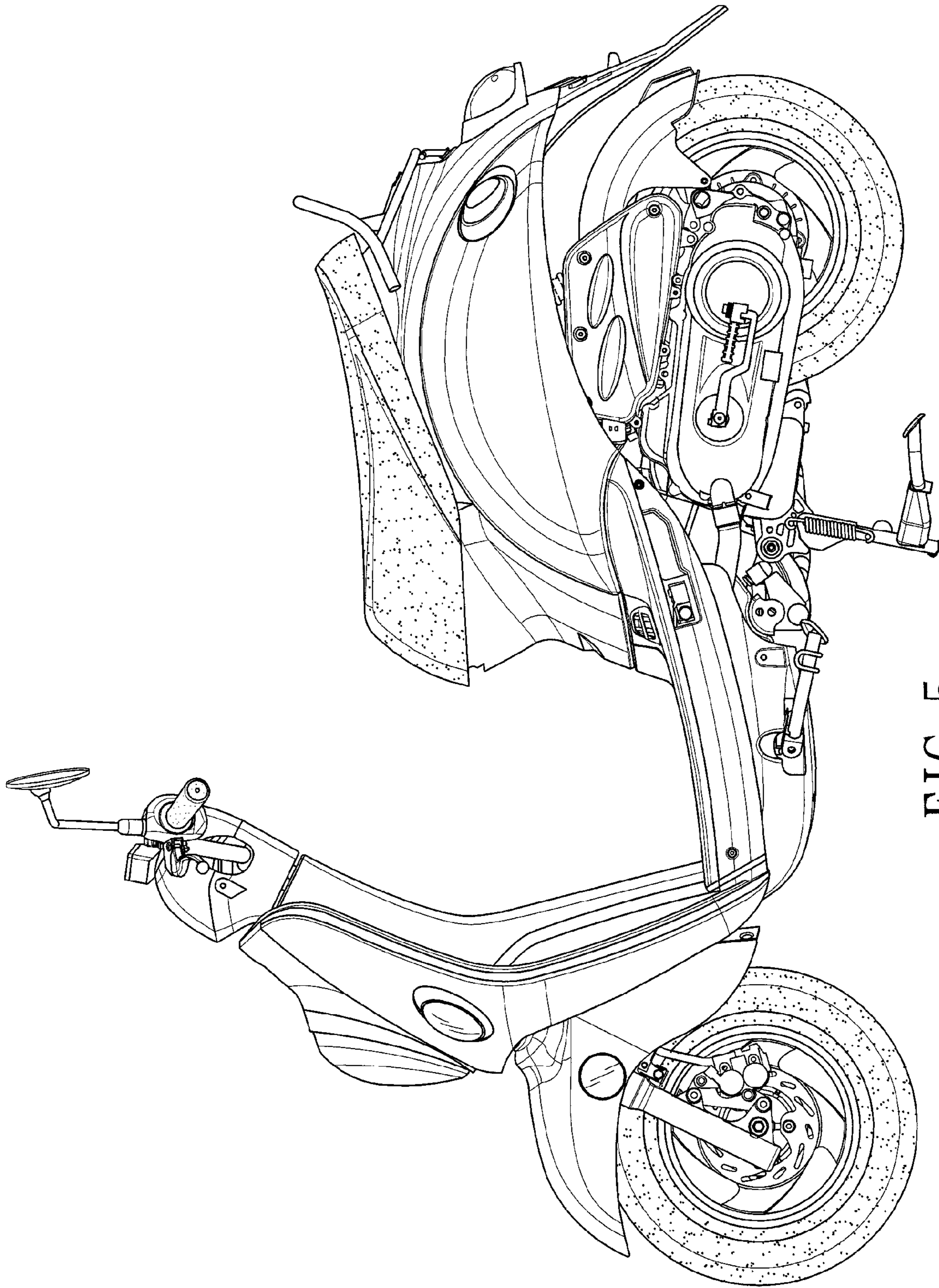

FIG. 5

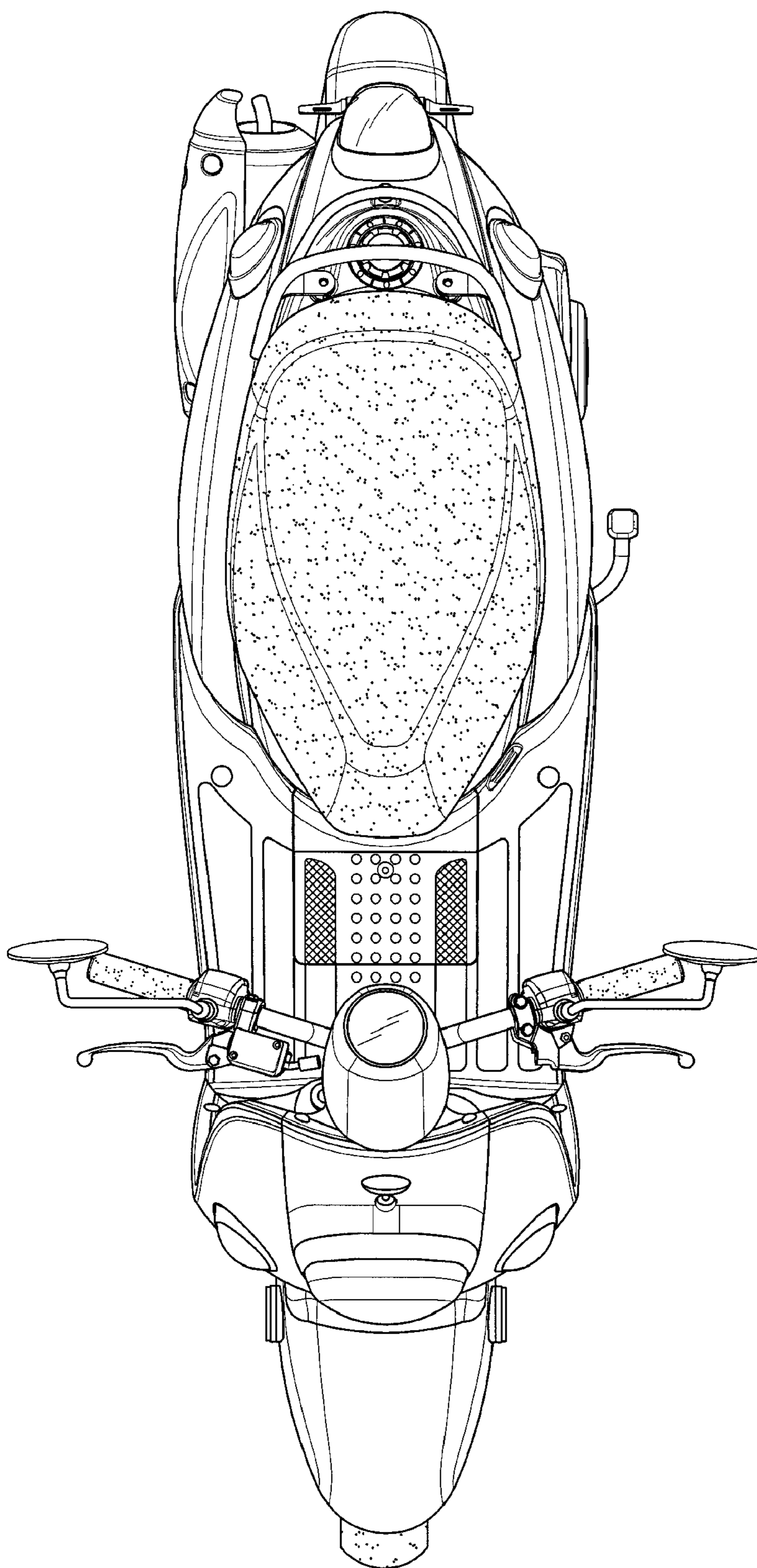

FIG. 6

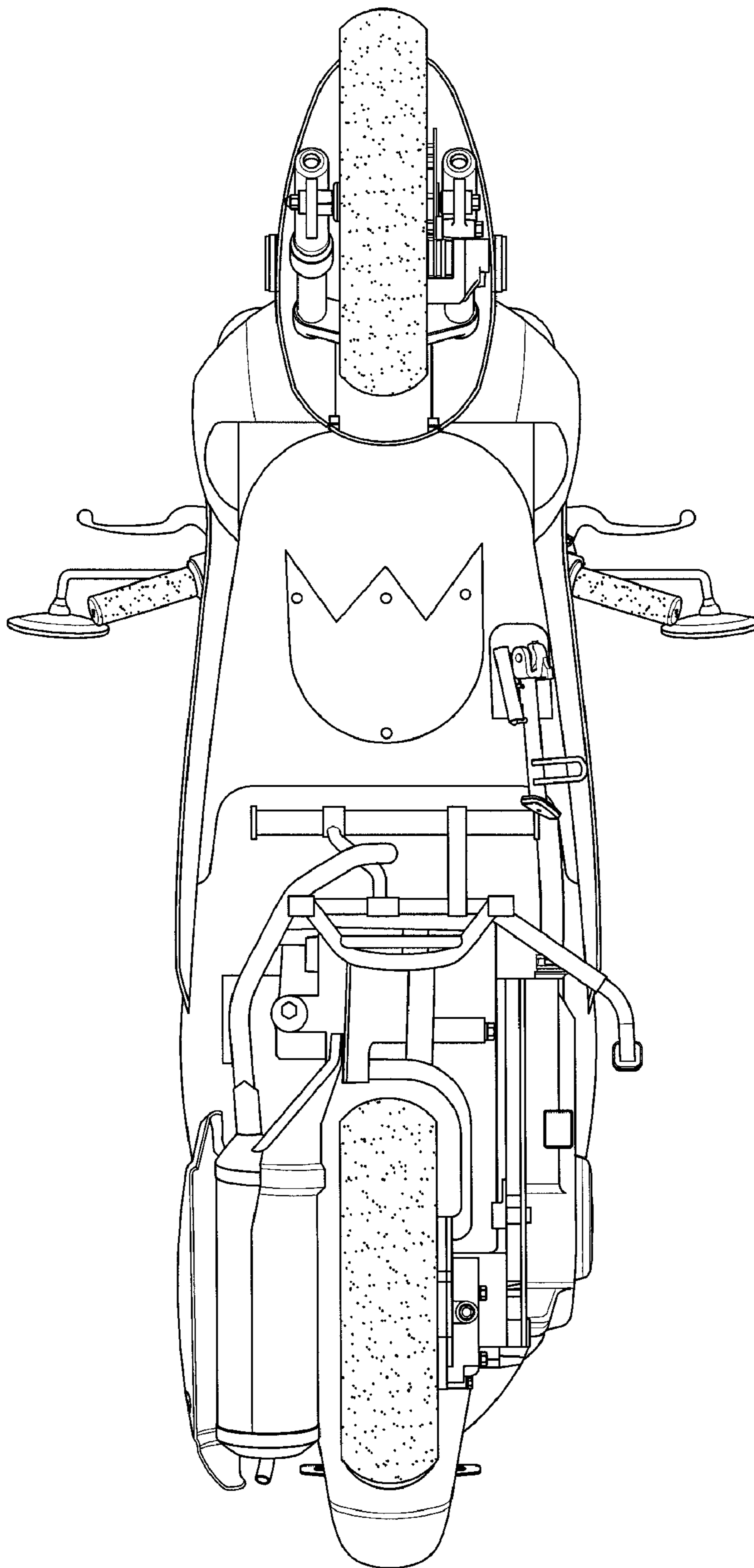

FIG. 7