



US00D584996S

(12) **United States Design Patent**  
**Jamieson et al.**

(10) **Patent No.:** **US D584,996 S**  
(45) **Date of Patent:** **\*\* Jan. 20, 2009**

(54) **VEHICLE EXTERIOR**

(75) Inventors: **Stuart Jamieson**, Chelsea, MI (US);  
**Freeman Thomas**, Laguna Beach, CA  
(US); **David Woodhouse**, Newport  
Coast, CA (US); **Ehab Kaoud**, Canton,  
MI (US)

(73) Assignee: **Ford Motor Company**, Dearborn, MI  
(US)

(\*\*) Term: **14 Years**

(21) Appl. No.: **29/299,812**

(22) Filed: **Jan. 4, 2008**

(51) **LOC (9) Cl.** ..... **12-08**

(52) **U.S. Cl.** ..... **D12/91**

(58) **Field of Classification Search** ..... D12/86,  
D12/90-92; 296/181.1, 181.5  
See application file for complete search history.

(56) **References Cited**

**U.S. PATENT DOCUMENTS**

|              |        |               |        |
|--------------|--------|---------------|--------|
| D559,742 S   | 1/2008 | Thomas et al. |        |
| D561,646 S   | 2/2008 | Thomas et al. |        |
| D561,658 S   | 2/2008 | Thomas et al. |        |
| D563,277 S   | 3/2008 | Thomas et al. |        |
| D569,767 S * | 5/2008 | Abe et al.    | D12/91 |
| D570,250 S * | 6/2008 | Nakamura      | D12/91 |

**OTHER PUBLICATIONS**

Roth, Dan; "Detroit Auto Show: Ford Airstream Concept"; Autoblog website article, located at [www.autoblog.com/2007/01/07/detroit-auto-show-ford-airstream-concept/](http://www.autoblog.com/2007/01/07/detroit-auto-show-ford-airstream-concept/); 16 pages; Jan. 7, 2007.  
Thomas, David; "2006 L.A. Auto Show: Ford Explorer Fuel Cell"; Cars.com Kicking Tires article, located at [http://blogs.cars.com/kickingtires/2006/11/2006\\_la\\_auto\\_sh\\_4.html](http://blogs.cars.com/kickingtires/2006/11/2006_la_auto_sh_4.html); 3 pages; Nov. 28, 2006.  
"Ford F-250 Super Chief Concept: A Bold, American Flex Fuel Pickup That Delivers Tomorrow's Fuel Today"; Ford Motor Company Press Release, located at [http://media.ford.com/newsroom/release\\_display.cfm?release=22295](http://media.ford.com/newsroom/release_display.cfm?release=22295); 5 pages; Jan. 8, 2006.

Pund, Daniel, "The Bold and the Brutiful: Ford designs another rear-drive sport sedan concept," Edmunds website article, located at <http://www.edmunds.com/insideline/do/Features/articleId=118988>; 2 pages; Dec. 30, 2006.

"2008 Explorer Maintains Leadership Among Midsize SUVs With Unmatched Features And Equipment"; Ford press release posted on Zer Customs website, located at <http://www.zercustoms.com/news/2008-ford-explorer.html>; 3 pages; July 11, 2007.

\* cited by examiner

*Primary Examiner*—Melody N Brown

(74) *Attorney, Agent, or Firm*—Frank A. MacKenzie; Brooks Kushman P.C.

(57) **CLAIM**

The ornamental design for a vehicle exterior, as shown and described.

**DESCRIPTION**

FIG. 1 is a front perspective view of a vehicle exterior showing our new design.

FIG. 2 is a front/right side perspective view of the vehicle exterior of FIG. 1, wherein a front/left side perspective view is a mirror image thereof;

FIG. 3 is a right side perspective view of the vehicle exterior of FIG. 1, wherein a left side perspective view is a mirror image thereof;

FIG. 4 is a rear/right side/top perspective view of the vehicle exterior of FIG. 1;

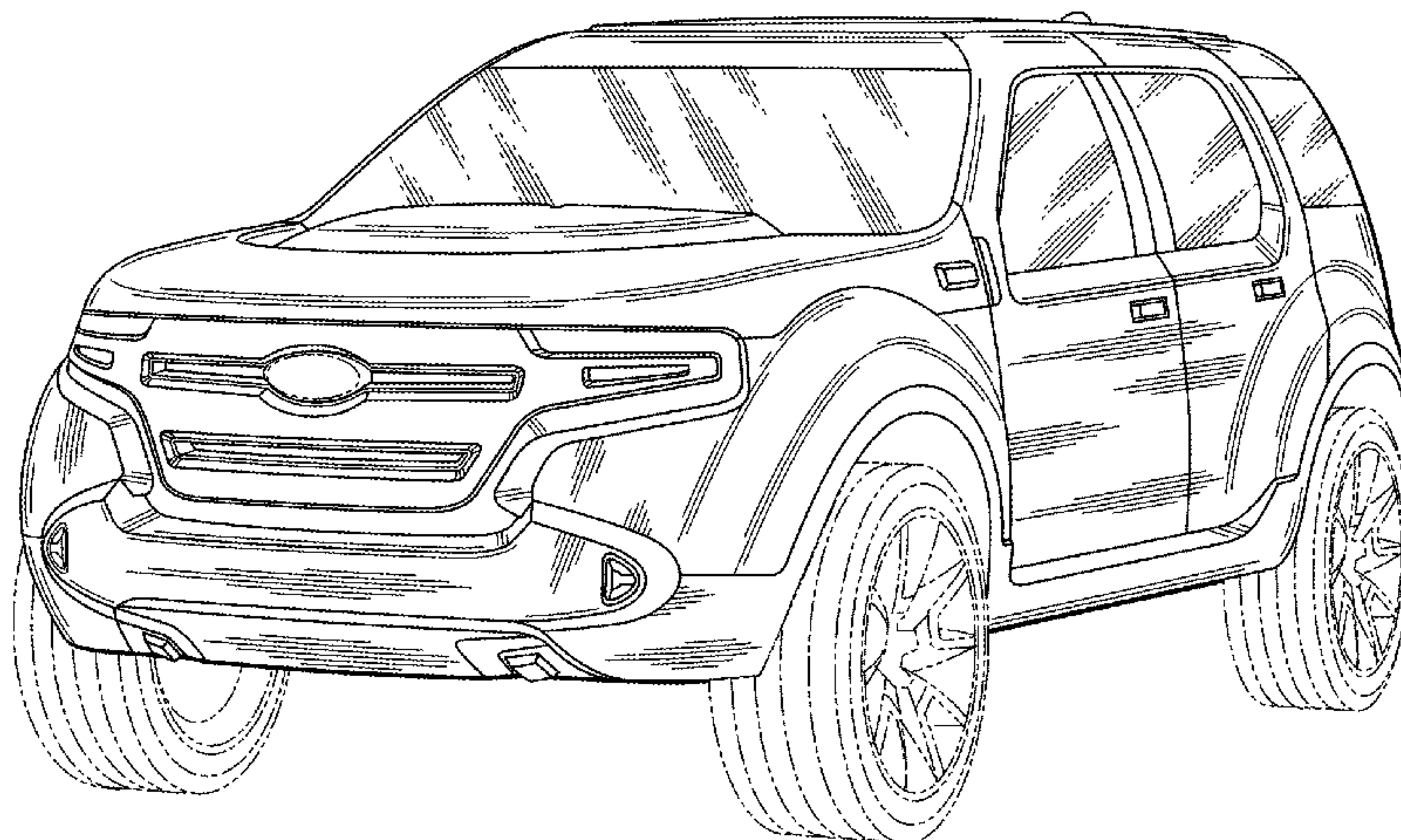
FIG. 5 is a rear perspective view of the vehicle exterior of FIG. 1;

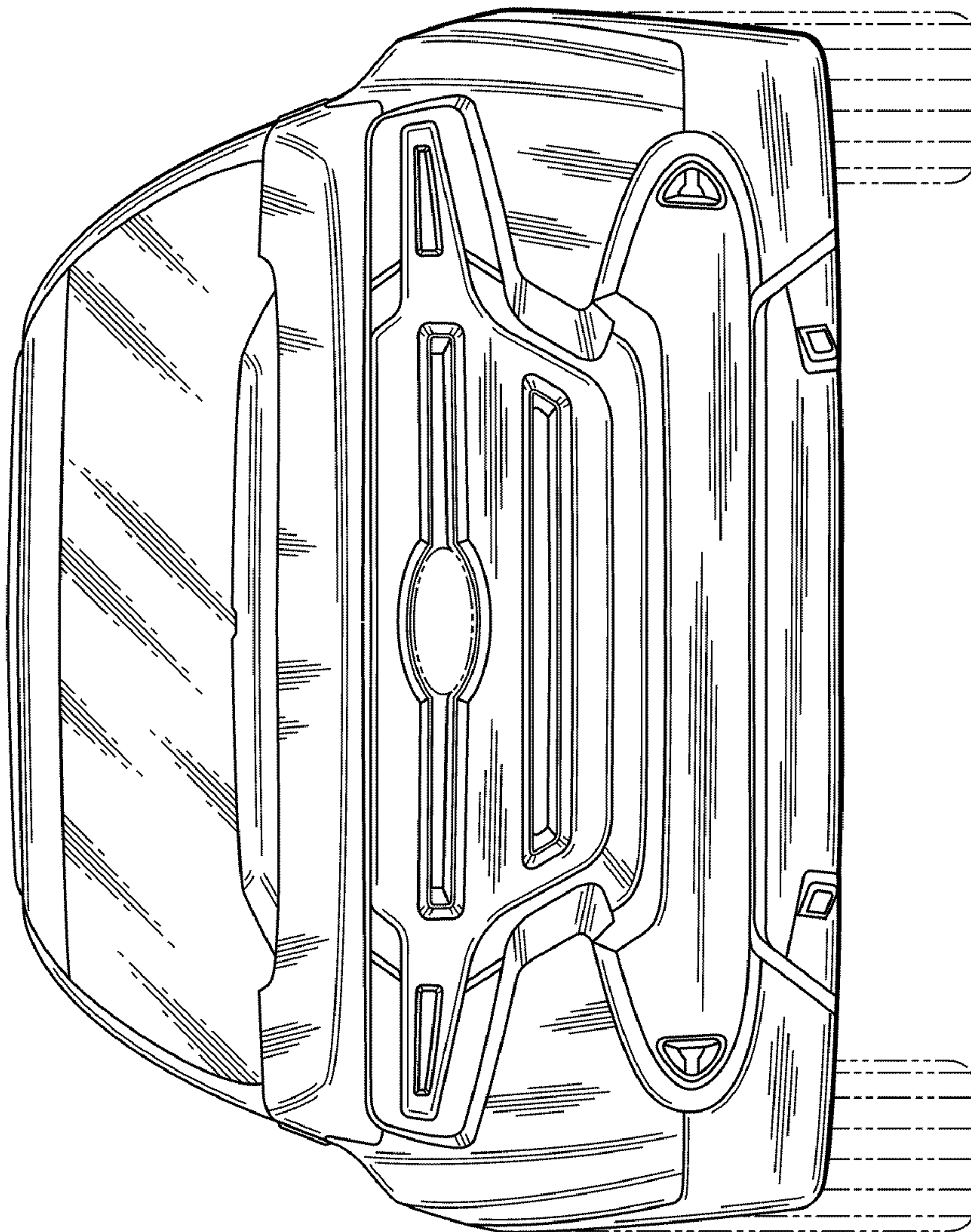
FIG. 6 is a rear/left side perspective view of the vehicle exterior of FIG. 1, wherein a rear/right side perspective view is a mirror image thereof; and,

FIG. 7 is a top plan view of the vehicle exterior of FIG. 1.

The broken lines showing logos and vehicle wheels are for illustrative purposes only and form no part of the claimed design.

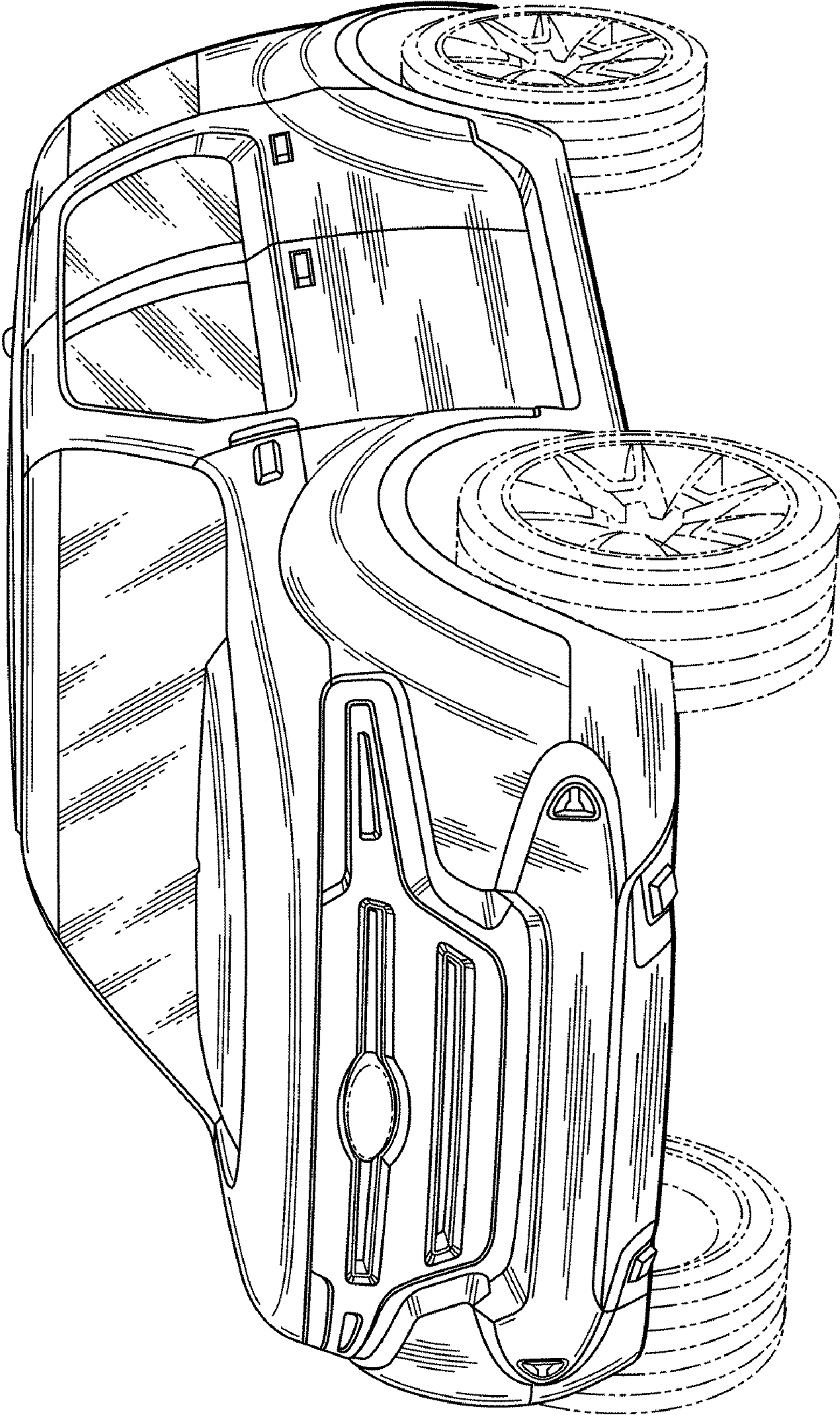
**1 Claim, 7 Drawing Sheets**



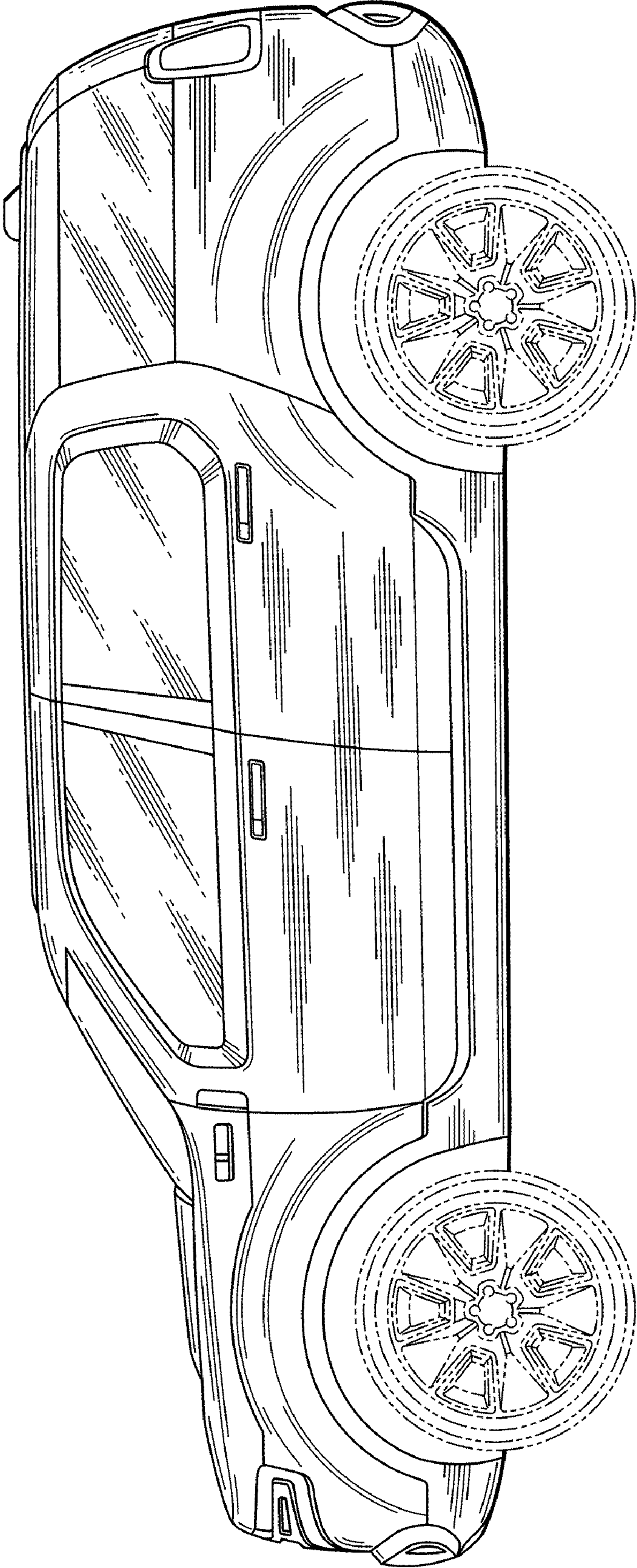


*Fig. 1*



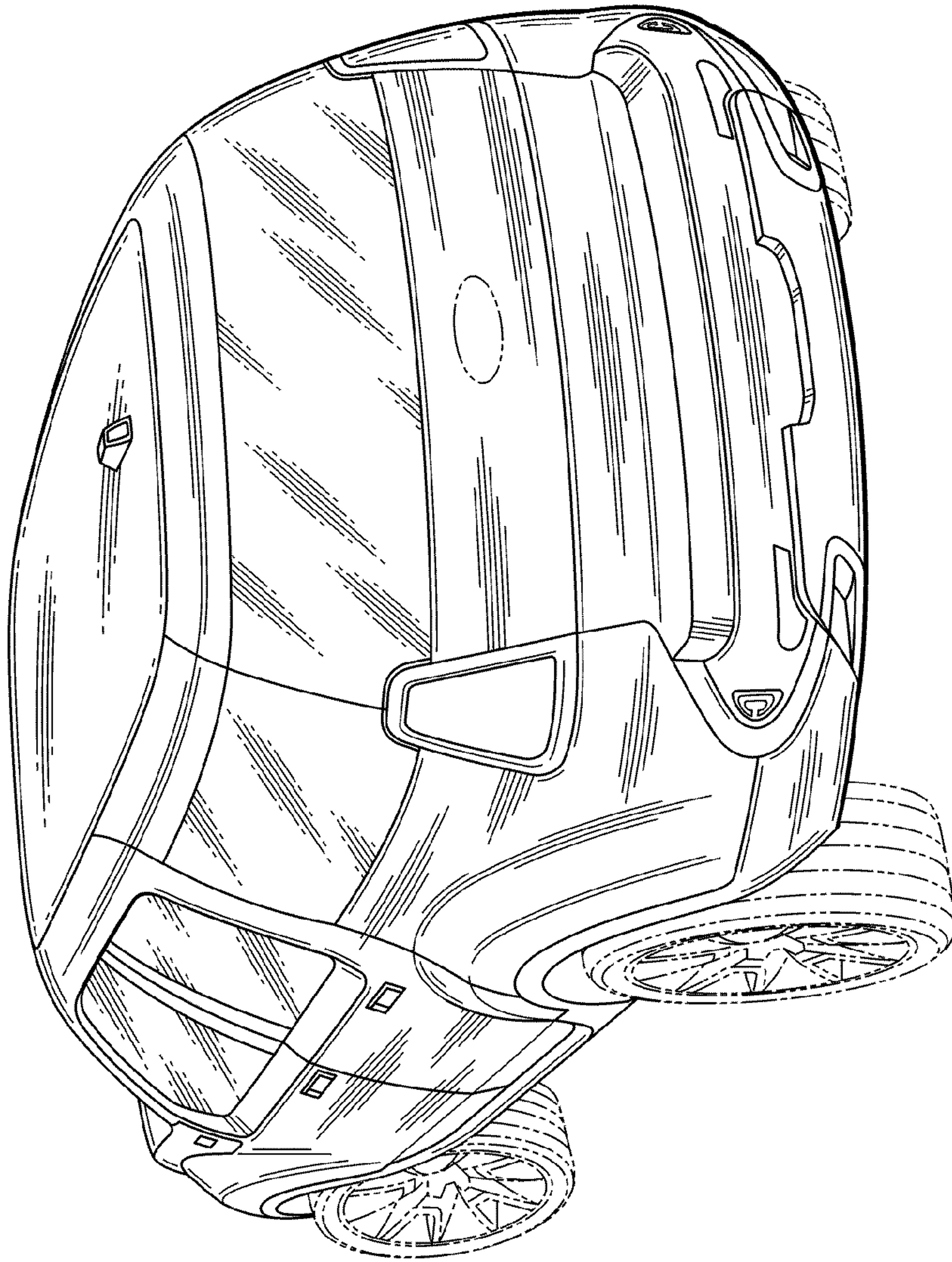


*Fig. 2*

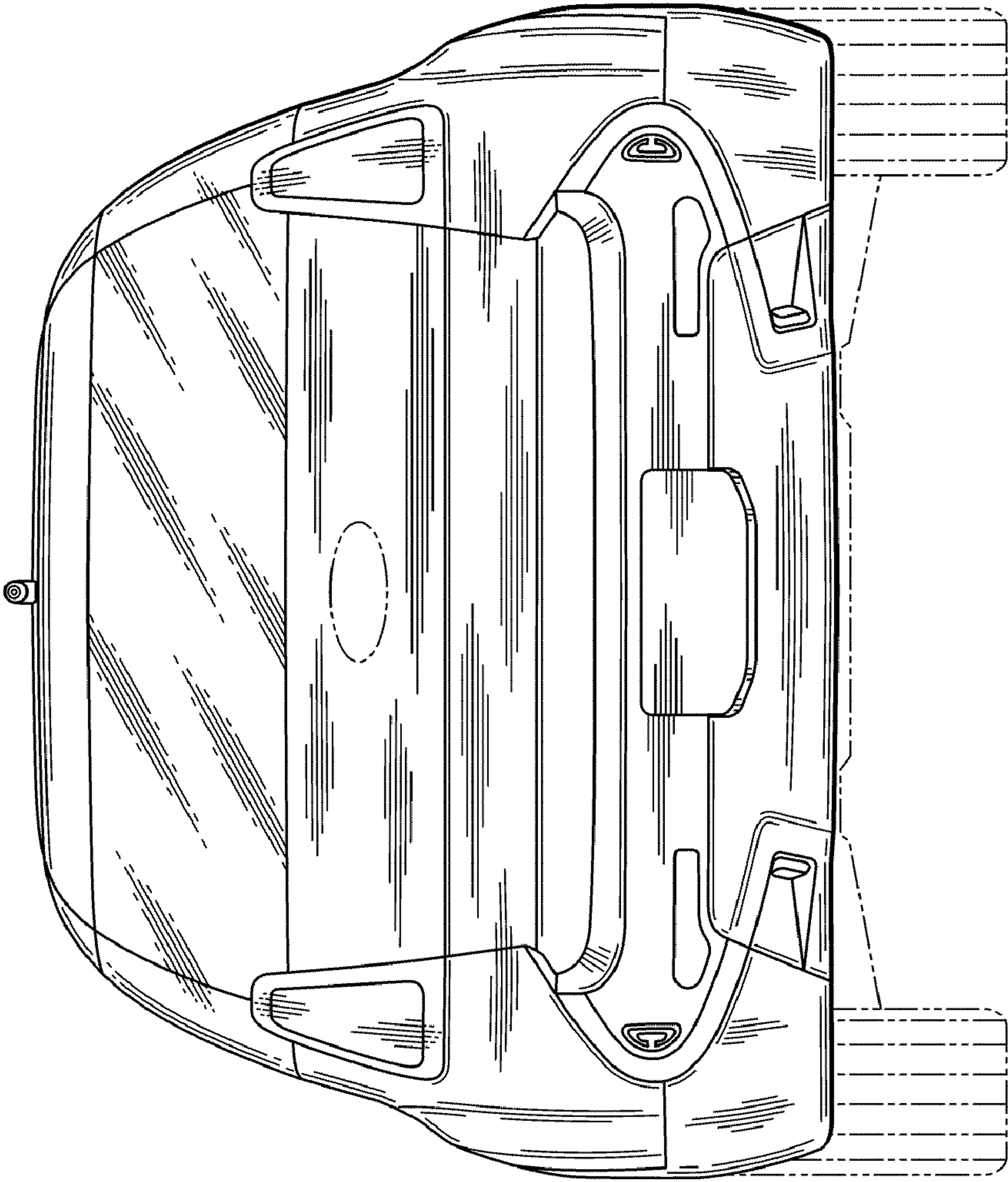


*Fig. 3*



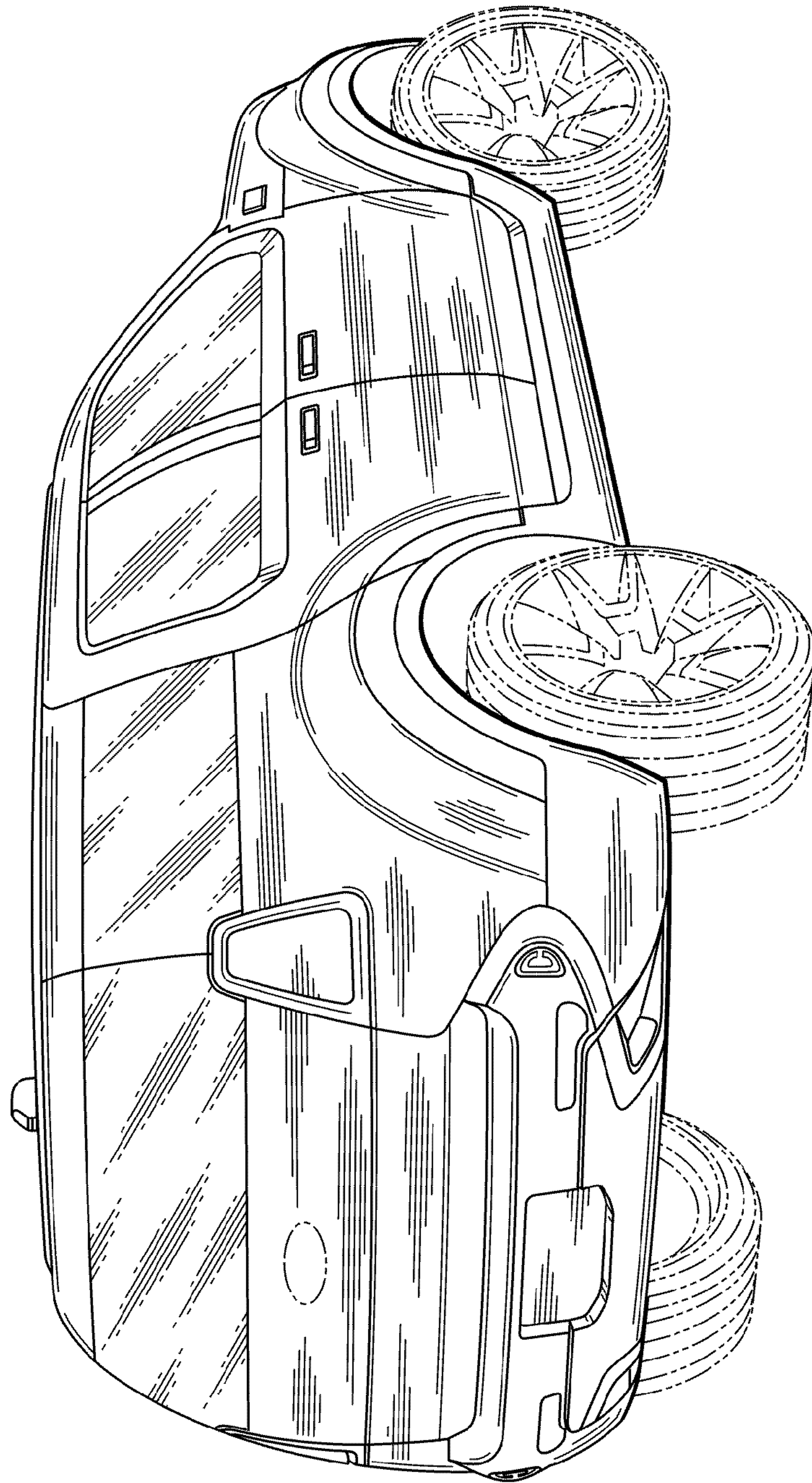


*Fig. 4*

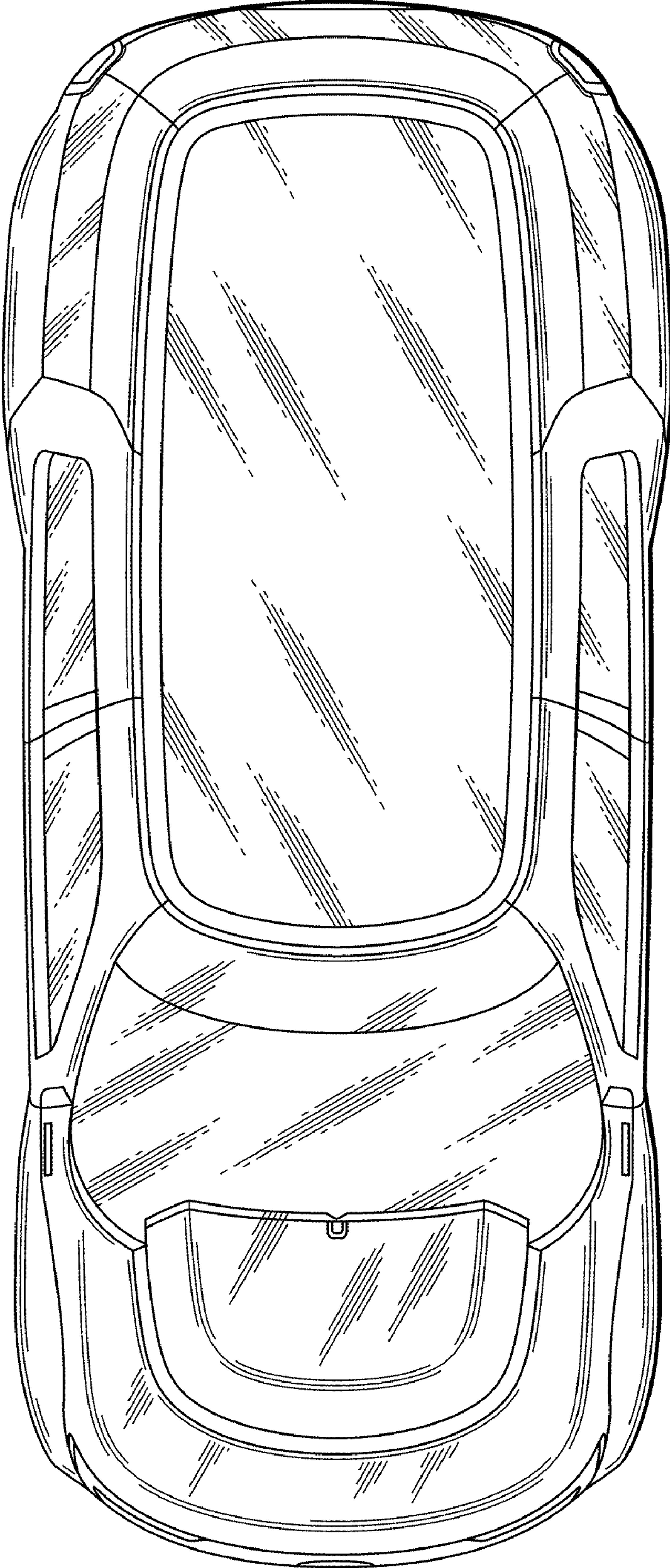


*Fig. 5*





*Fig. 6*



*Fig. 7*