



US00D584971S

(12) **United States Design Patent**
Contreras

(10) **Patent No.:** **US D584,971 S**
(45) **Date of Patent:** **** Jan. 20, 2009**

(54) **FLAT COMPASS FOR MARKING LARGE ARCS**

(76) Inventor: **Amaury D. Contreras**, 16479 Pine Forest St., Fontana, CA (US) 92336

(**) Term: **14 Years**

(21) Appl. No.: **29/307,106**

(22) Filed: **Apr. 1, 2008**

(51) **LOC (9) Cl.** **10-04**

(52) **U.S. Cl.** **D10/63**

(58) **Field of Classification Search** D10/63;
D19/38; 33/27.01, 27.03, 27.031-27.033
See application file for complete search history.

(56) **References Cited**

U.S. PATENT DOCUMENTS

1,005,827	A	10/1911	Gombarts	
2,419,752	A	4/1947	Zumbuhl	
2,681,507	A	6/1954	Underwood	
2,818,644	A	1/1958	Crawford	
4,334,360	A	6/1982	Burns et al.	
4,616,418	A	10/1986	Wade, III	
5,033,197	A	7/1991	Irvello	
5,651,184	A	7/1997	Tutty	
7,191,530	B1 *	3/2007	Thibodeaux 33/27.032
2003/0182811	A1	10/2003	Hairapetian	

* cited by examiner

Primary Examiner—Antoine D Davis

(74) *Attorney, Agent, or Firm*—Kirk A. Buhler; Buhler & Associates

(57) **CLAIM**

The ornamental design of a flat compass for marking large arcs, as shown and described.

DESCRIPTION

FIG. 1 is an isometric perspective view of a preferred embodiment shown with a ruler and fat pencil of the flat compass for marking large arcs.

FIG. 2 is an alternate isometric view of a preferred embodiment of the flat compass for marking large arcs.

FIG. 3 is a top view of a preferred embodiment of the flat compass for marking large arcs.

FIG. 4 is a bottom view of a preferred embodiment of the flat compass for marking large arcs.

FIG. 5 is a front view of a preferred embodiment of the flat compass for marking large arcs.

FIG. 6 is a back view of a preferred embodiment of the flat compass for marking large arcs.

FIG. 7 is a right side view of a preferred embodiment of the flat compass for marking large arcs; and,

FIG. 8 is a left side view of a preferred embodiment of the flat compass for marking large arcs.

The broken lines in FIG. 1 depict environmental subject matter of a ruler and a pencil and are or are not part of the claimed design and are being shown for the convenience of illustration.

1 Claim, 5 Drawing Sheets

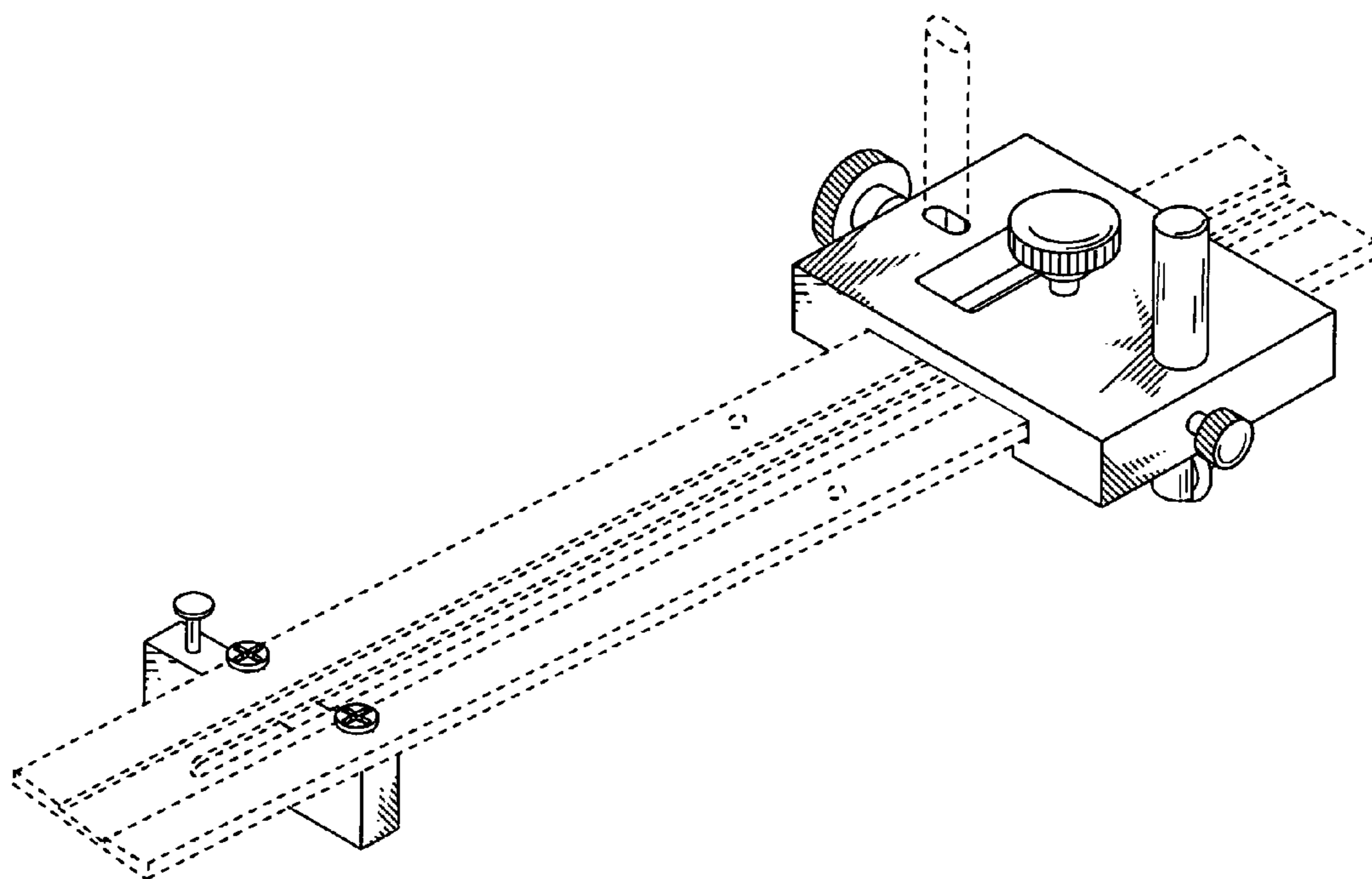

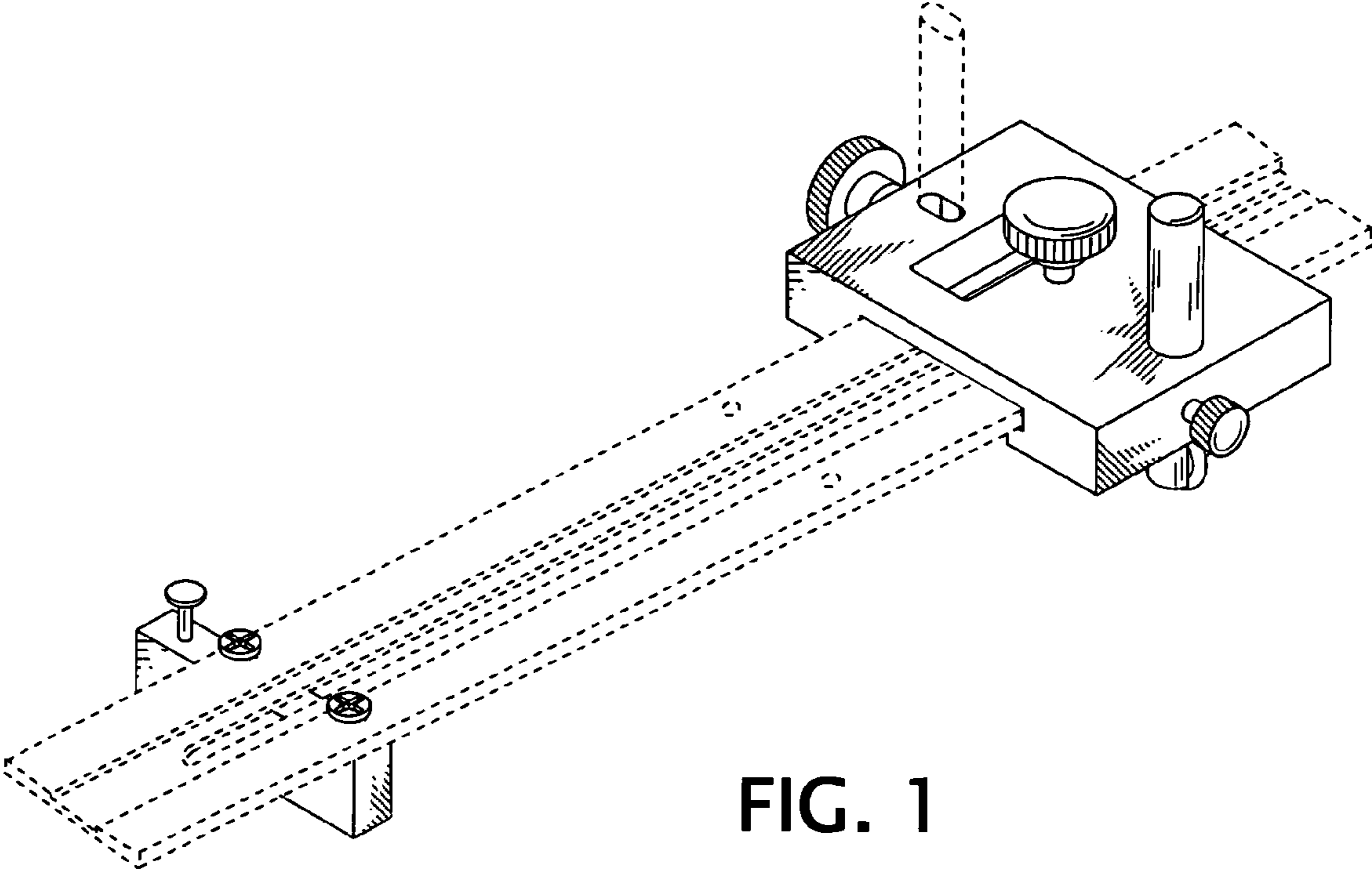

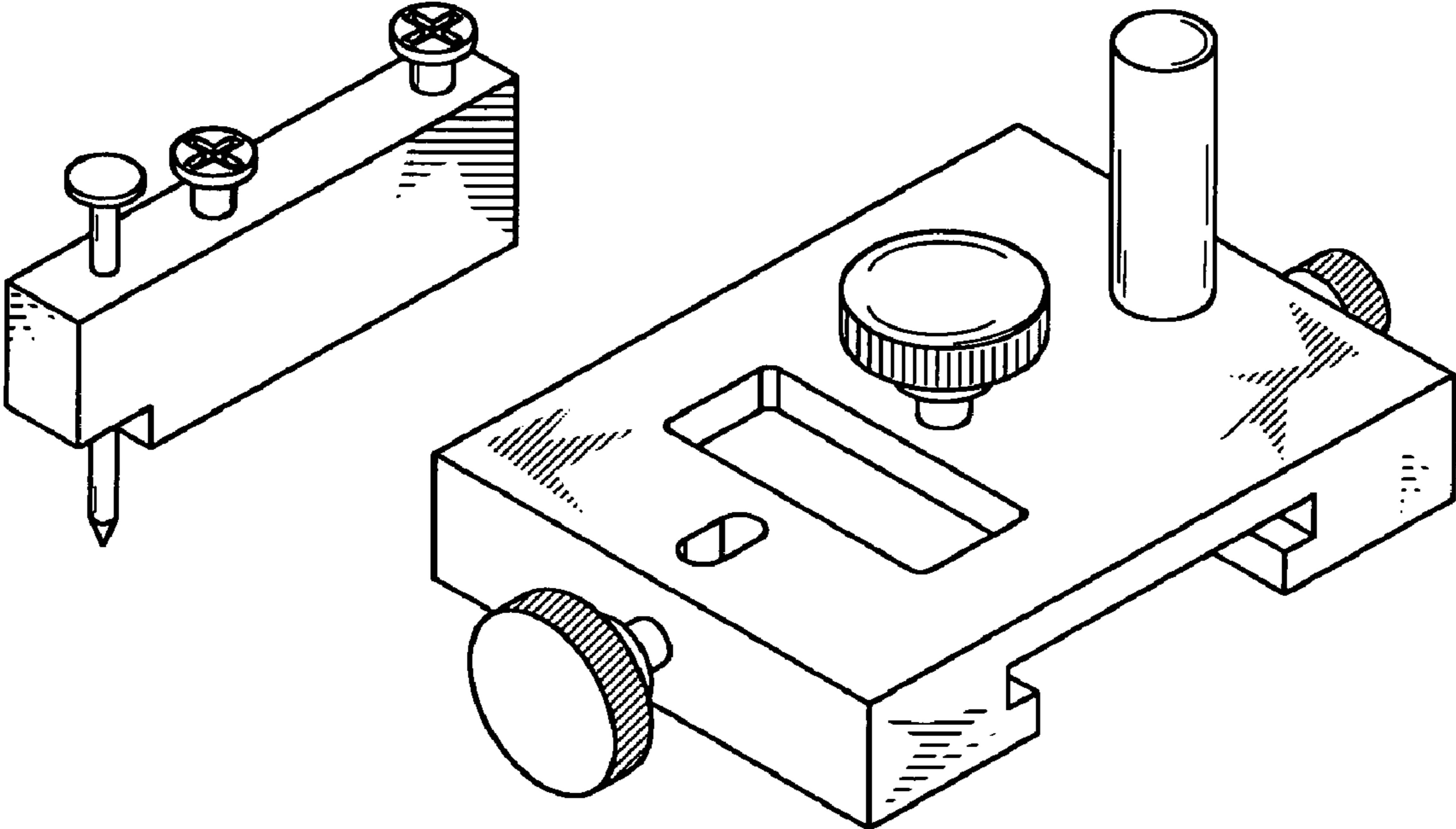
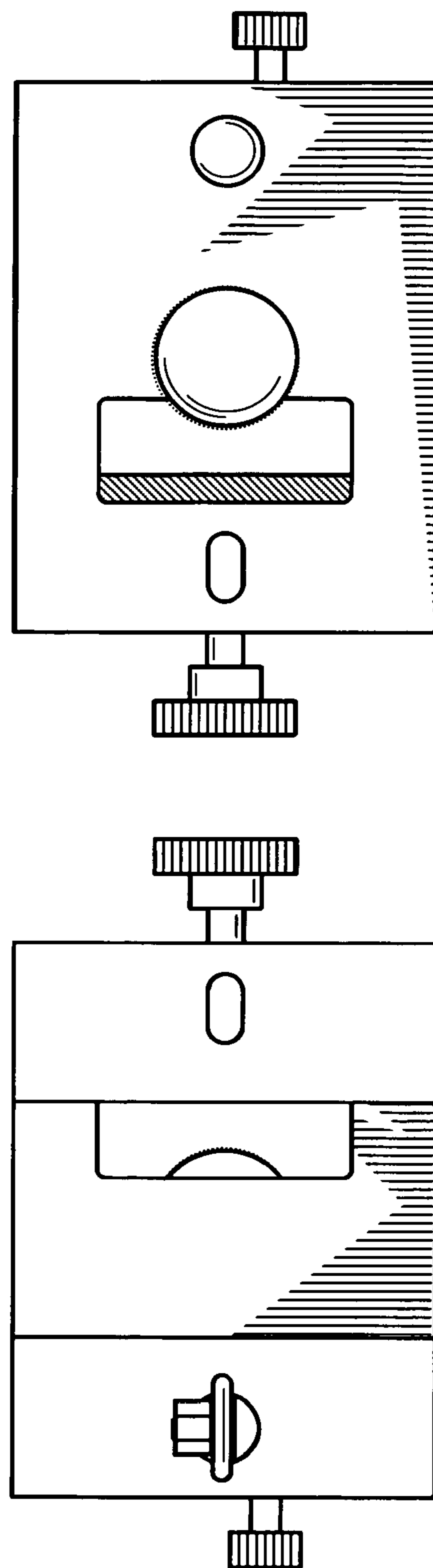
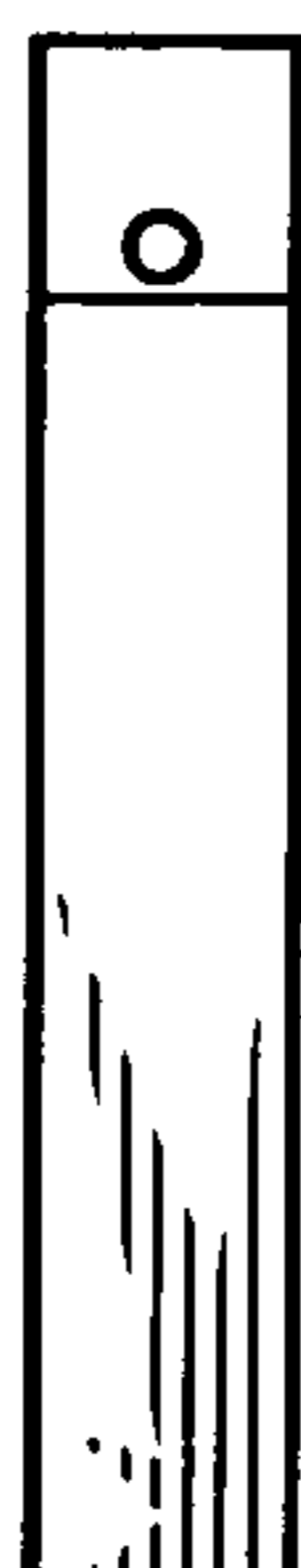

FIG. 2

FIG. 3



FIG. 4



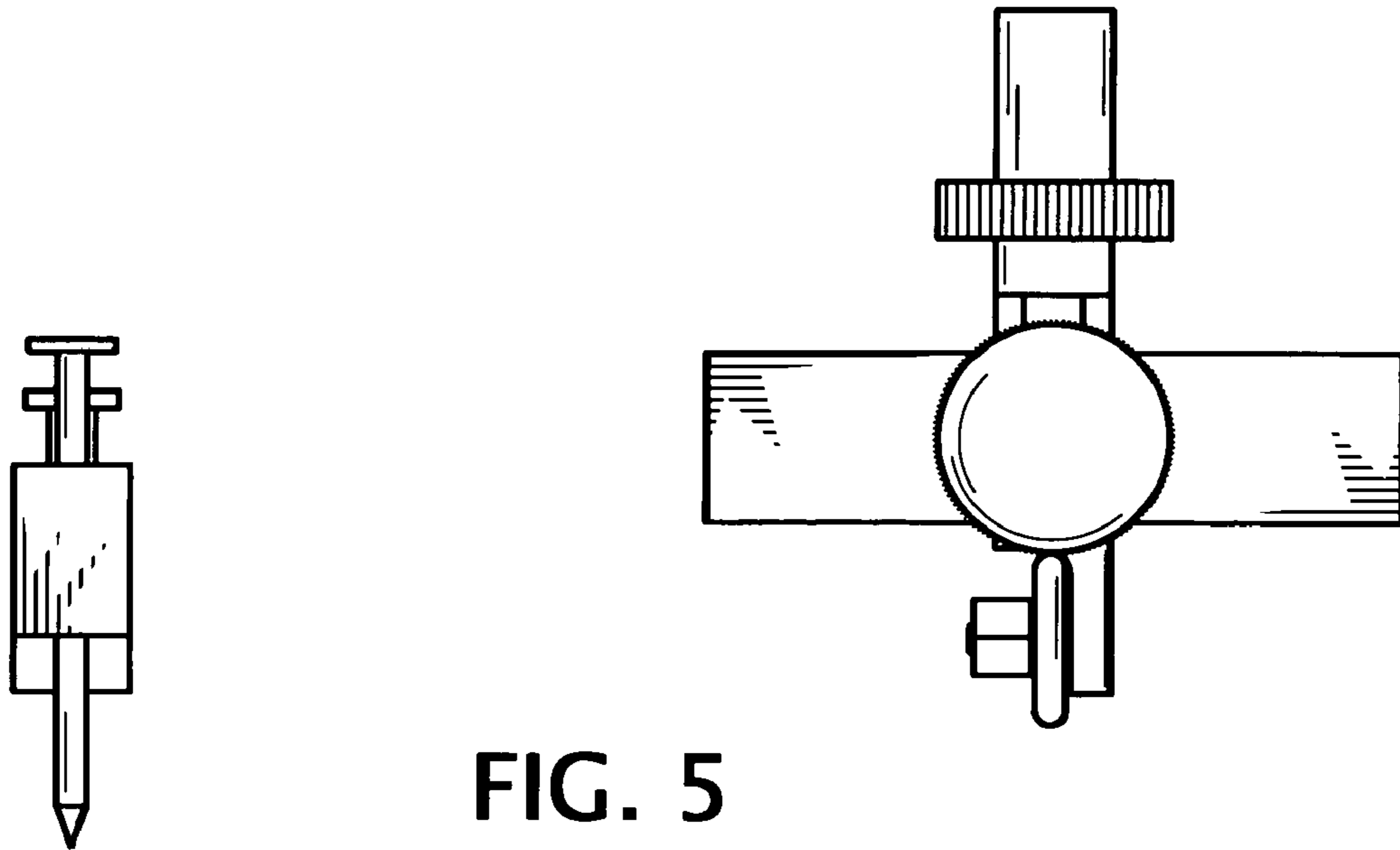

FIG. 5

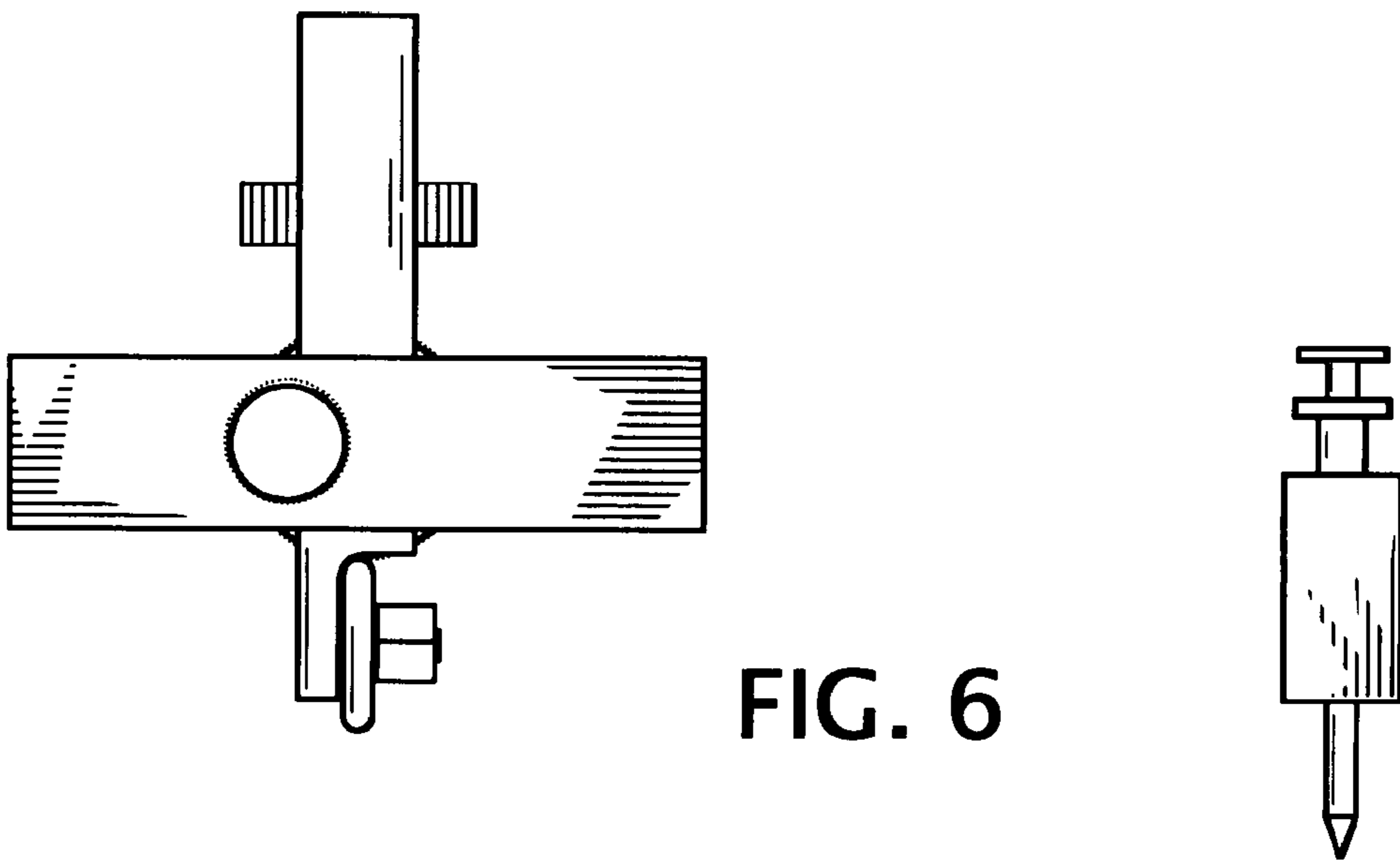

FIG. 6

