



US00D584873S

(12) **United States Design Patent**
Kuraoka et al.

(10) **Patent No.:** **US D584,873 S**
(45) **Date of Patent:** **** Jan. 13, 2009**

(54) **FORK LIFT TRUCK**

(75) Inventors: **Ryoichi Kuraoka**, Isehara (JP);
Yoshinaka Tanaka, Zama (JP)

(73) Assignee: **Nissan Motor Co., Ltd.**, Yokohama-shi
(JP)

(**) Term: **14 Years**

(21) Appl. No.: **29/302,785**

(22) Filed: **Jan. 24, 2008**

(30) **Foreign Application Priority Data**

Aug. 10, 2007 (JP) 2007-021885

(51) **LOC (9) Cl.** **12-05**

(52) **U.S. Cl.** **D34/34**

(58) **Field of Classification Search** D34/34,
D34/28; 187/222, 237, 238; 414/631; 180/89.12,
180/89.13, 89.17

See application file for complete search history.

(56) **References Cited**

U.S. PATENT DOCUMENTS

D448,136 S *	9/2001	Yurushi et al.	D34/34
D471,340 S *	3/2003	Shibata et al.	D34/34
D526,460 S *	8/2006	Goto et al.	D34/34
D557,872 S *	12/2007	Mori et al.	D34/35
D570,575 S *	6/2008	Stark	D34/34

FOREIGN PATENT DOCUMENTS

JP	1236695	4/2005
JP	1281935	9/2006
JP	1295858	3/2007
JP	1318129	12/2007

OTHER PUBLICATIONS

“H40-70FT Series” by Hyster Company (copyright 2005), 2 pgs.

“Diesel-/Treibgasstapler DFG/TFG 316s-550s mit hydrostatik-Antrieb,” by Jungheinrich Aktiengesellschaft (published on or earlier than Oct. 2005), 3 pgs.

“1.0-3.5 ton Gasoline & Diesel Forklift Trucks LEO Next V,” by Komatsu Forklift (published on or earlier than Dec. 2004), p. 2-3 and 14-15.

“Linde 39X 392/393 Series,” by Komatsu Forklift (published on Sep. 2003), 4 pgs.

“Acroba,” by TCM K.K. (published on or earlier than Apr. 2002), pp. 7 and 8.

“TCM New Stage Inoma Forklift Trucks 1-3t,” by TCM K.K., (published on or earlier than Dec. 2005), pp. 3, 4, 13 and 14.

“8 Series 3,000-6,500 lbs,” by Toyota Material Handling U.S.A., (Copyright 2006), 4 pgs.

“Geneo”, By Toyota L & F, (publication data unknown), pp. 1-4 and 7-10.

“Veracitor™ GP-VX Pneumatic Tire Trucks,” by Yale Materials Handling Corporation (Copyright 2005), 3 pgs.

* cited by examiner

Primary Examiner—Cynthia E Ramirez

(74) *Attorney, Agent, or Firm*—Foley & Lardner LLP

(57) **CLAIM**

The ornamental design for a fork lift truck, as shown and described.

DESCRIPTION

FIG. 1 is a left perspective view of a fork lift truck;

FIG. 2 is a right perspective view thereof;

FIG. 3 is a front view thereof;

FIG. 4 is a rear view thereof;

FIG. 5 is a top plan view thereof;

FIG. 6 is a left side view thereof; and,

FIG. 7 is a right side view thereof.

1 Claim, 4 Drawing Sheets

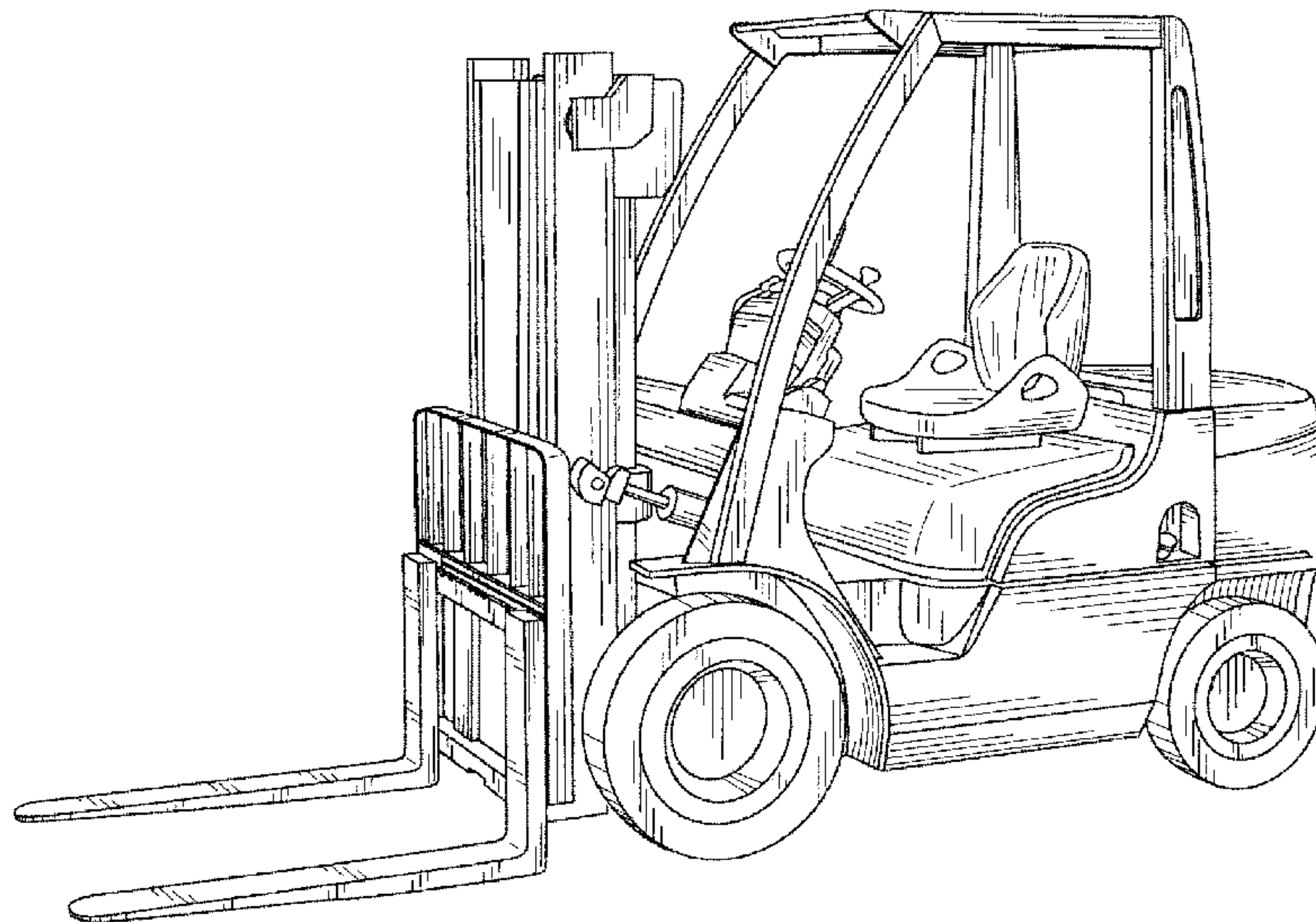

Fig.1

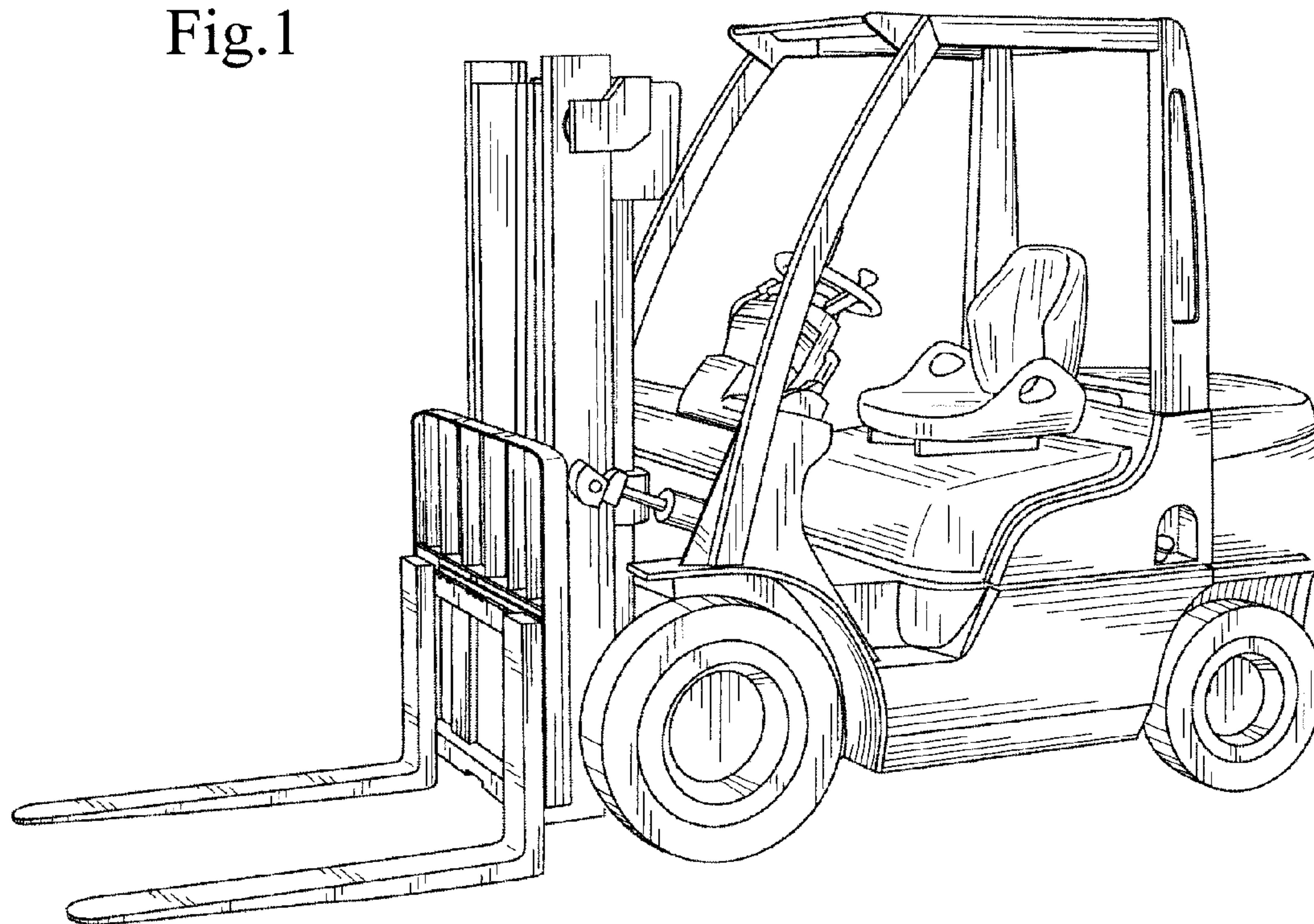

Fig.2



Fig.3

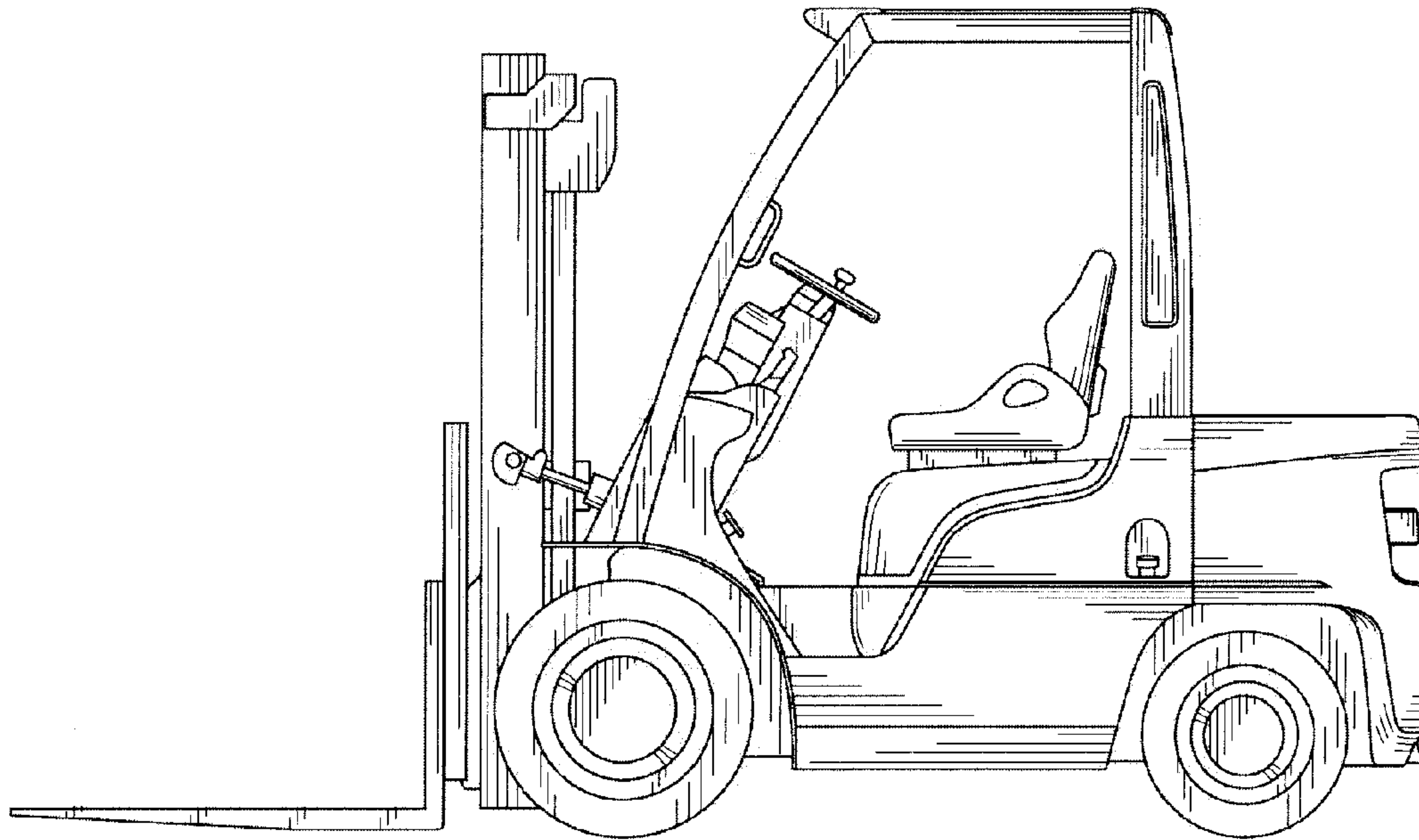

Fig.4

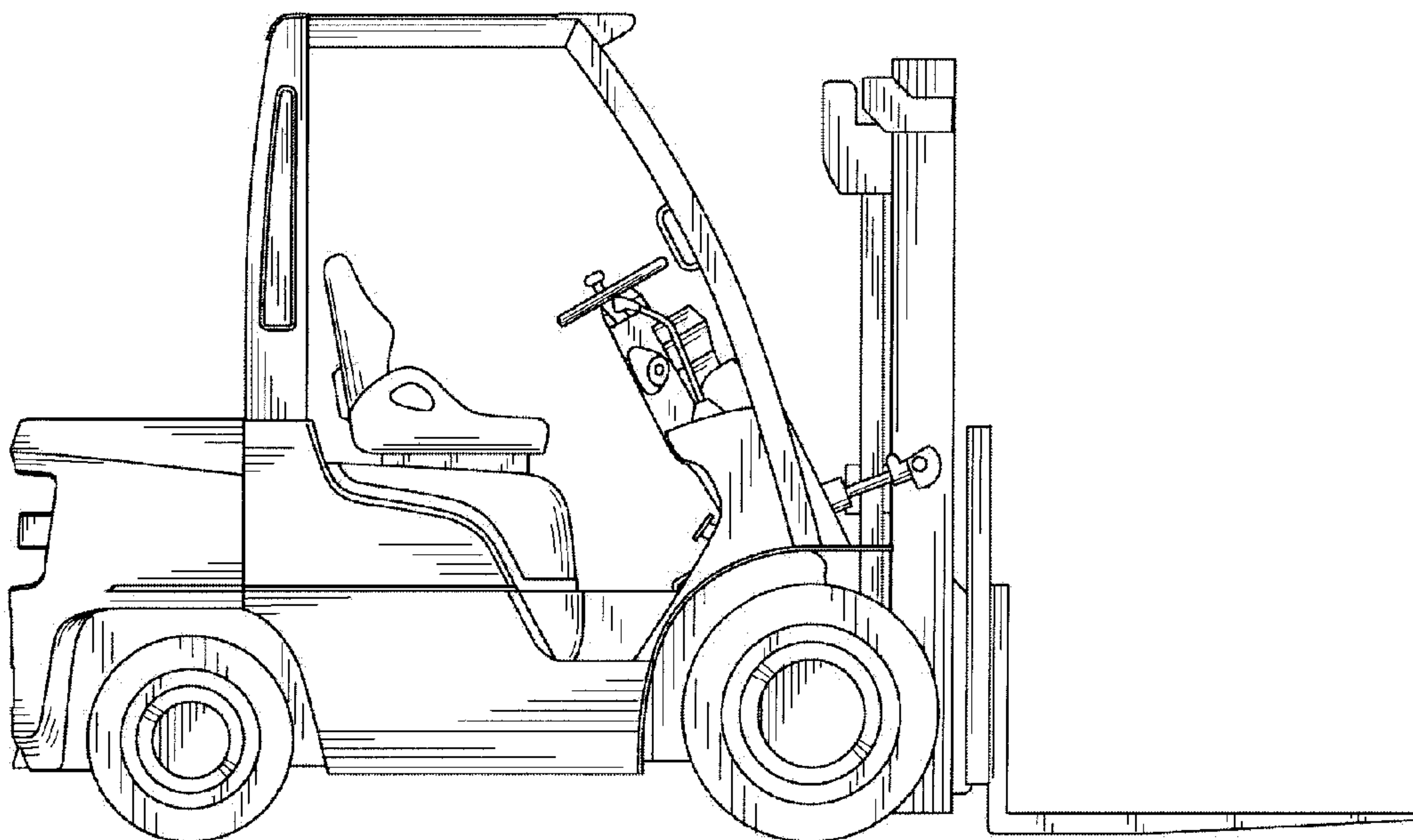

Fig.5

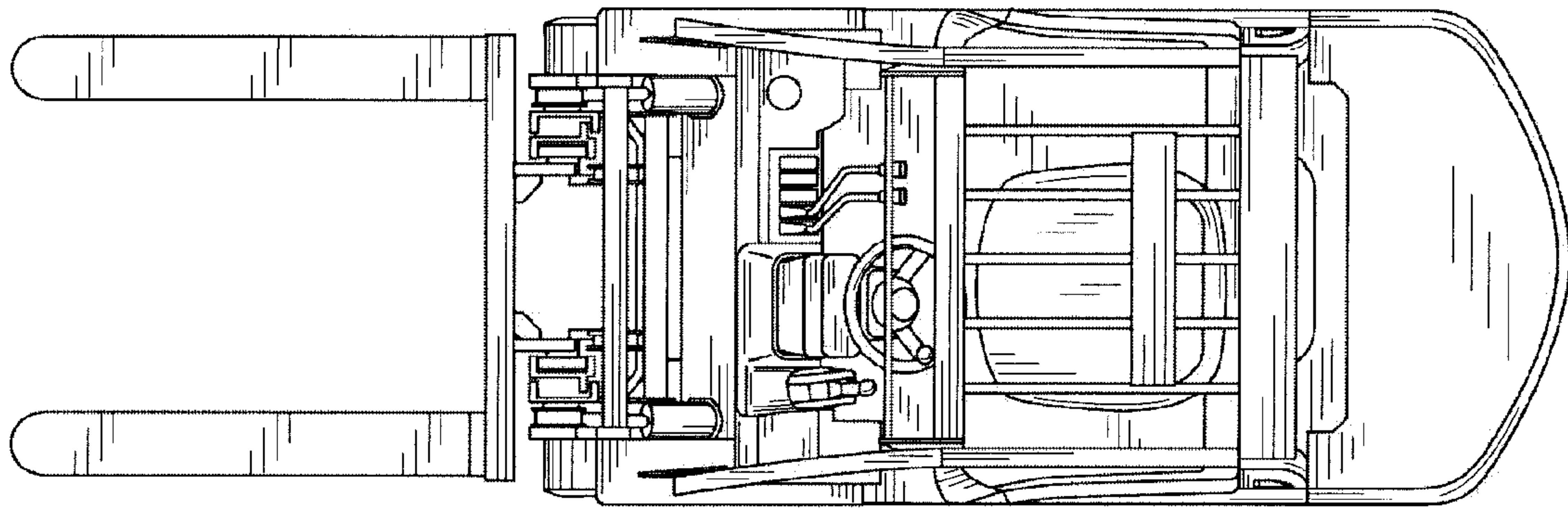

Fig.6

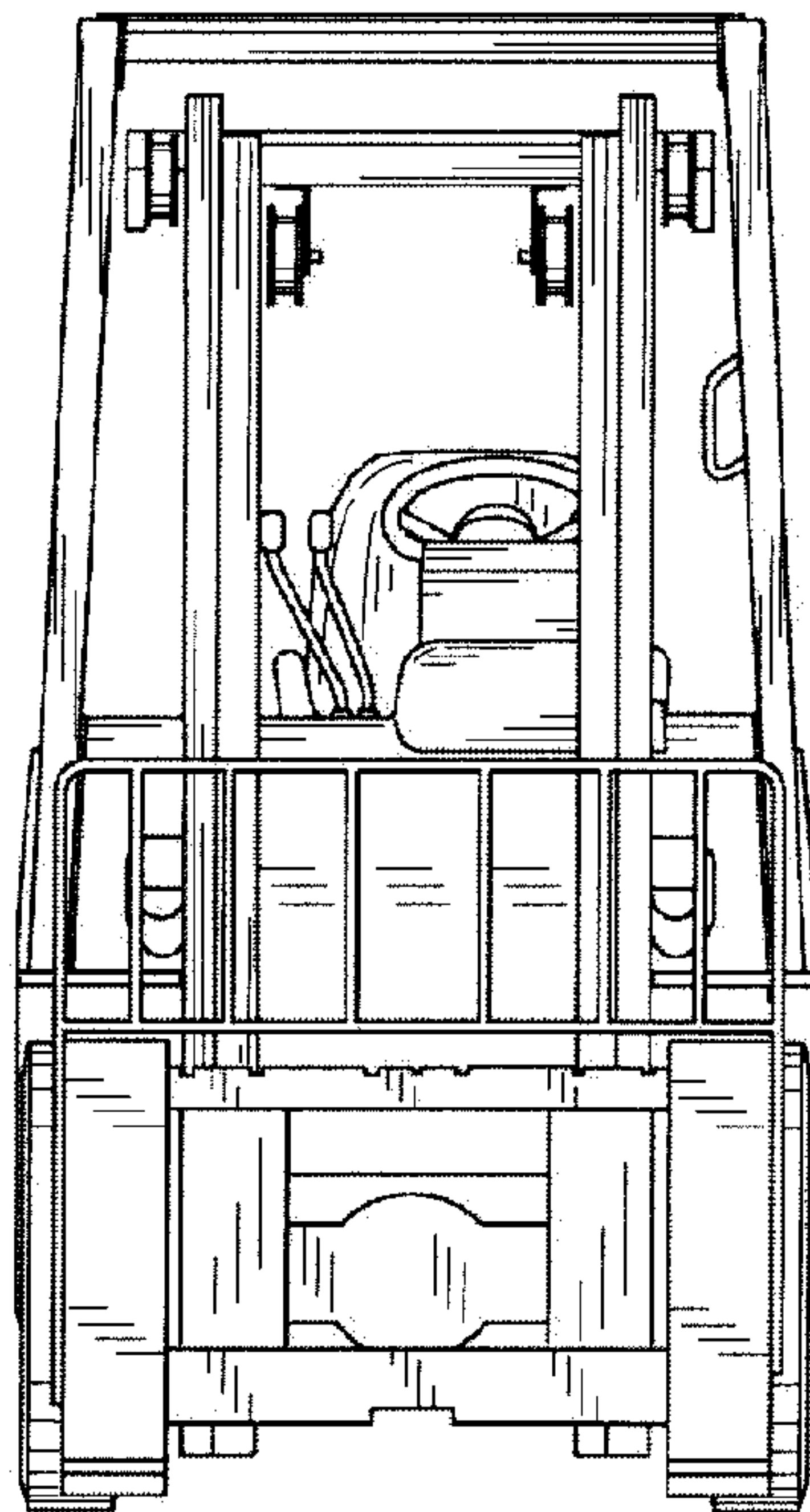

Fig. 7

