



US00D584699S

(12) **United States Design Patent**  
**Bando**

(10) **Patent No.:** **US D584,699 S**  
(45) **Date of Patent:** **\*\* Jan. 13, 2009**

(54) **LIGHT EMITTING DIODE**

(75) Inventor: **Yoshitaka Bando**, Tokushima (JP)  
(73) Assignee: **Nichia Corporation**, Anan-shi (JP)  
(\*\*) Term: **14 Years**  
(21) Appl. No.: **29/325,171**  
(22) Filed: **Sep. 26, 2008**

**Related U.S. Application Data**

(62) Division of application No. 29/318,364, filed on May 19, 2008, now Pat. No. Des. 580,381, which is a division of application No. 29/259,849, filed on May 17, 2006, now Pat. No. Des. 573,113.

**Foreign Application Priority Data**

(30)  
Dec. 9, 2005 (JP) ..... 2005-036420  
Dec. 9, 2005 (JP) ..... 2005-036424  
Dec. 9, 2005 (JP) ..... 2005-036425  
Dec. 9, 2005 (JP) ..... 2005-036426  
Dec. 9, 2005 (JP) ..... 2005-036427  
Dec. 9, 2005 (JP) ..... 2005-036428  
Dec. 9, 2005 (JP) ..... 2005-036429  
Dec. 9, 2005 (JP) ..... 2005-036430  
Dec. 9, 2005 (JP) ..... 2005-036431

(51) **LOC (9) Cl.** ..... **13-03**  
(52) **U.S. Cl.** ..... **D13/180**  
(58) **Field of Classification Search** ..... D13/180;  
D26/2; 257/79, 80, 81, 88, 89, 95, 98, 99,  
257/100; 313/483, 498, 500; 362/555, 800  
See application file for complete search history.

**References Cited**

**U.S. PATENT DOCUMENTS**

6,376,902 B1 \* 4/2002 Arndt ..... 257/678  
D471,166 S \* 3/2003 Oshio et al. .... D13/182  
6,586,721 B2 \* 7/2003 Estevez-Garcia ..... 250/221  
D486,801 S \* 2/2004 Suenaga ..... D13/182  
D491,899 S \* 6/2004 Yagi ..... D13/180  
D505,398 S \* 5/2005 Nakashima ..... D13/180  
D512,029 S \* 11/2005 Kim et al. .... D13/180

D551,180 S \* 9/2007 Song et al. .... D13/180  
D573,113 S \* 7/2008 Bando ..... D13/180  
D573,114 S \* 7/2008 Min et al. .... D13/180  
2004/0041222 A1 \* 3/2004 Loh ..... 257/433  
2004/0126913 A1 \* 7/2004 Loh ..... 438/26  
2005/0127816 A1 \* 6/2005 Sumitani ..... 313/498

\* cited by examiner

*Primary Examiner*—Selina Sikder

(74) *Attorney, Agent, or Firm*—Global IP Counselors, LLP

(57) **CLAIM**

The ornamental design for a light emitting diode, as shown and described.

**DESCRIPTION**

FIG. 1 is a front side perspective view of a light emitting diode in accordance with new design;

FIG. 2 is a rear side perspective view of the light emitting diode in accordance with my new design;

FIG. 3 is a front elevational view of the light emitting diode in accordance with my new design;

FIG. 4 is a rear elevational view of the light emitting diode in accordance with my new design;

FIG. 5 is a top plan view of the light emitting diode in accordance with my new design;

FIG. 6 is a bottom plan view of the light emitting diode in accordance with my new design;

FIG. 7 is a left side end elevational view of the light emitting diode in accordance with my new design;

FIG. 8 is a right side end elevational view of the light emitting diode in accordance with my new design; and,

FIG. 9 is a front elevational view of the light emitting diode in accordance with my new design with environment shown in broken lines.

The broken line showing of environment (the remaining structure of the light emitting diode) in the Figures is for illustrative purposes only and forms no part of the claimed design.

**1 Claim, 5 Drawing Sheets**

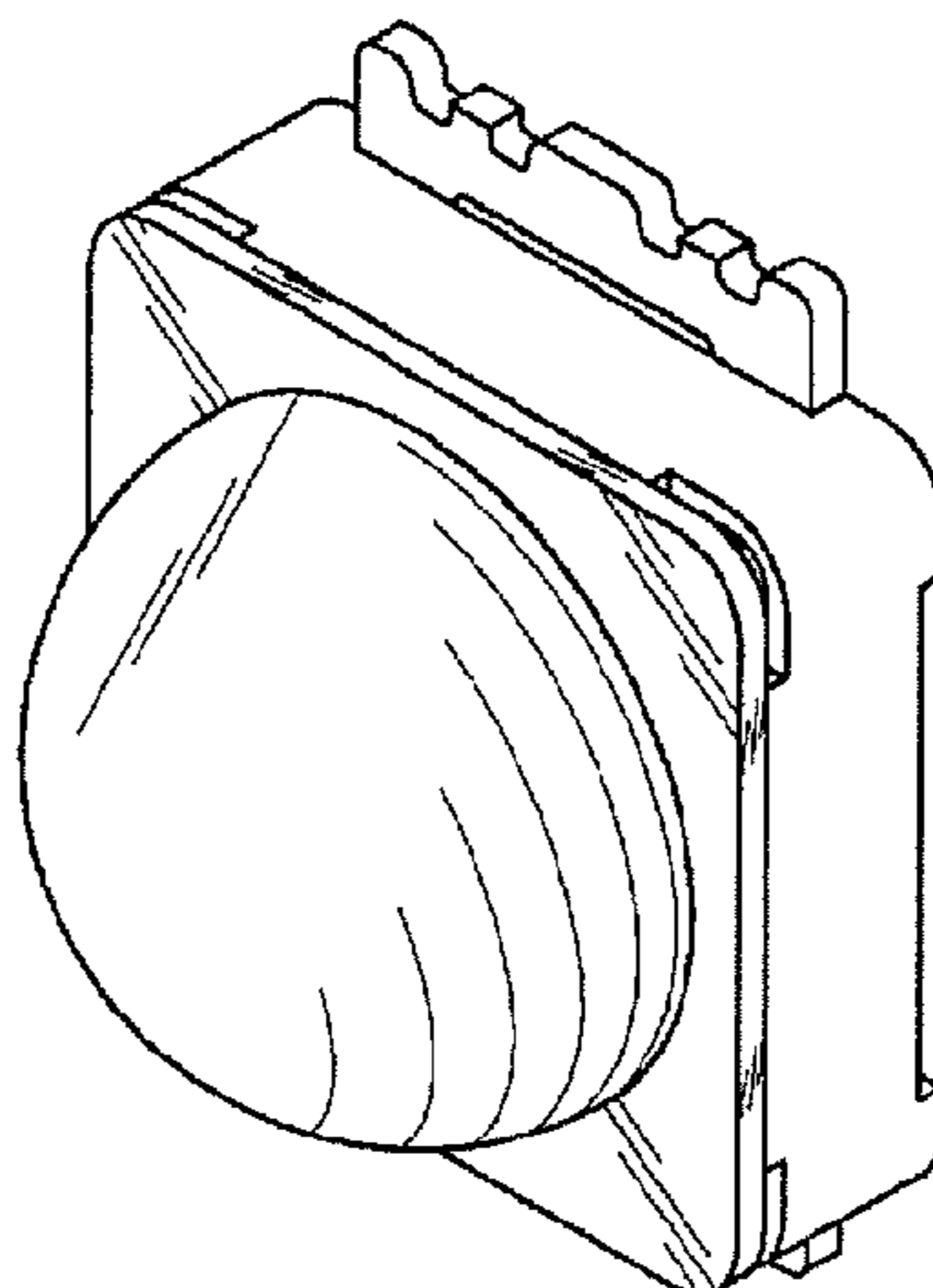

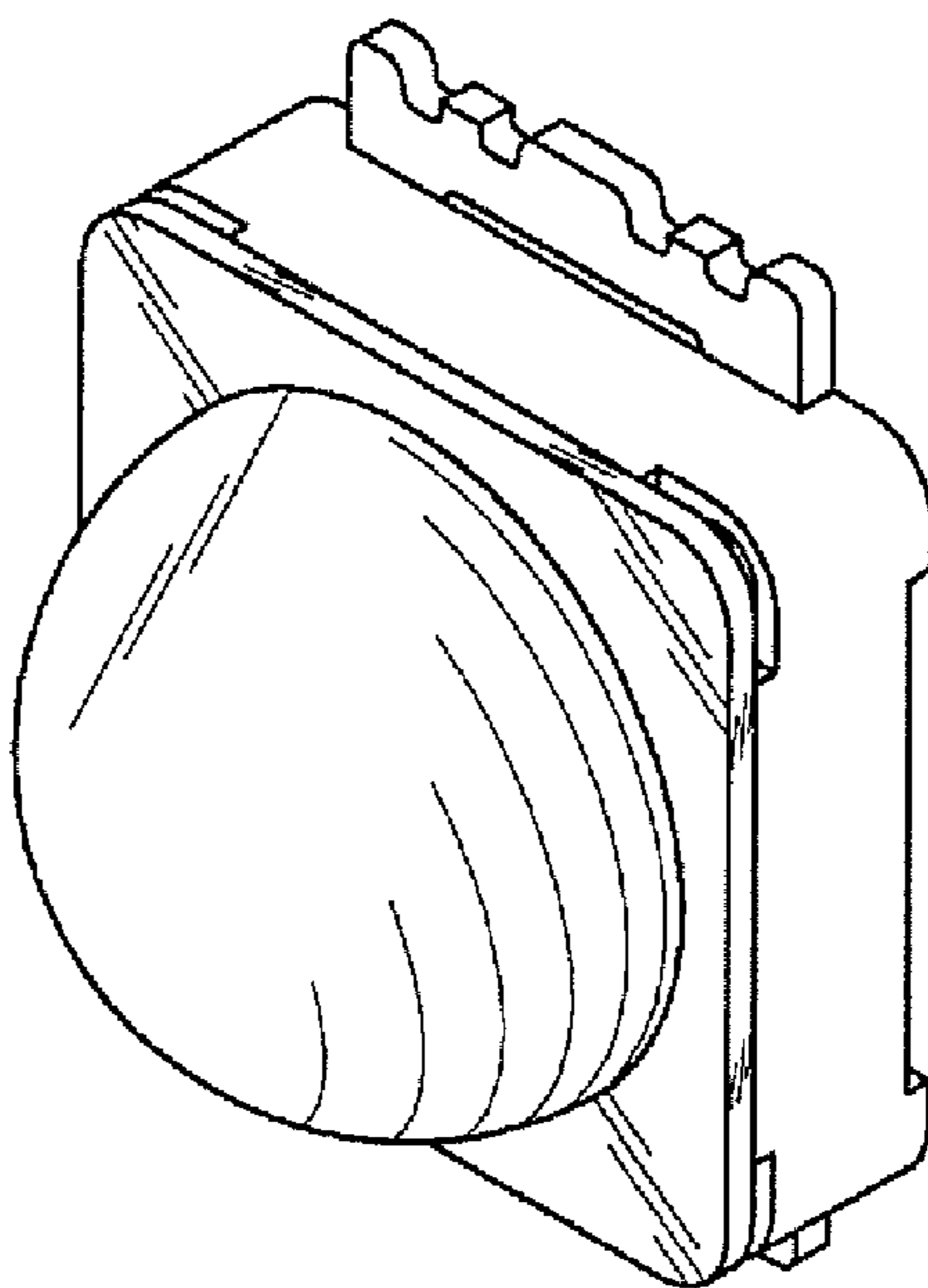

FIG. 1

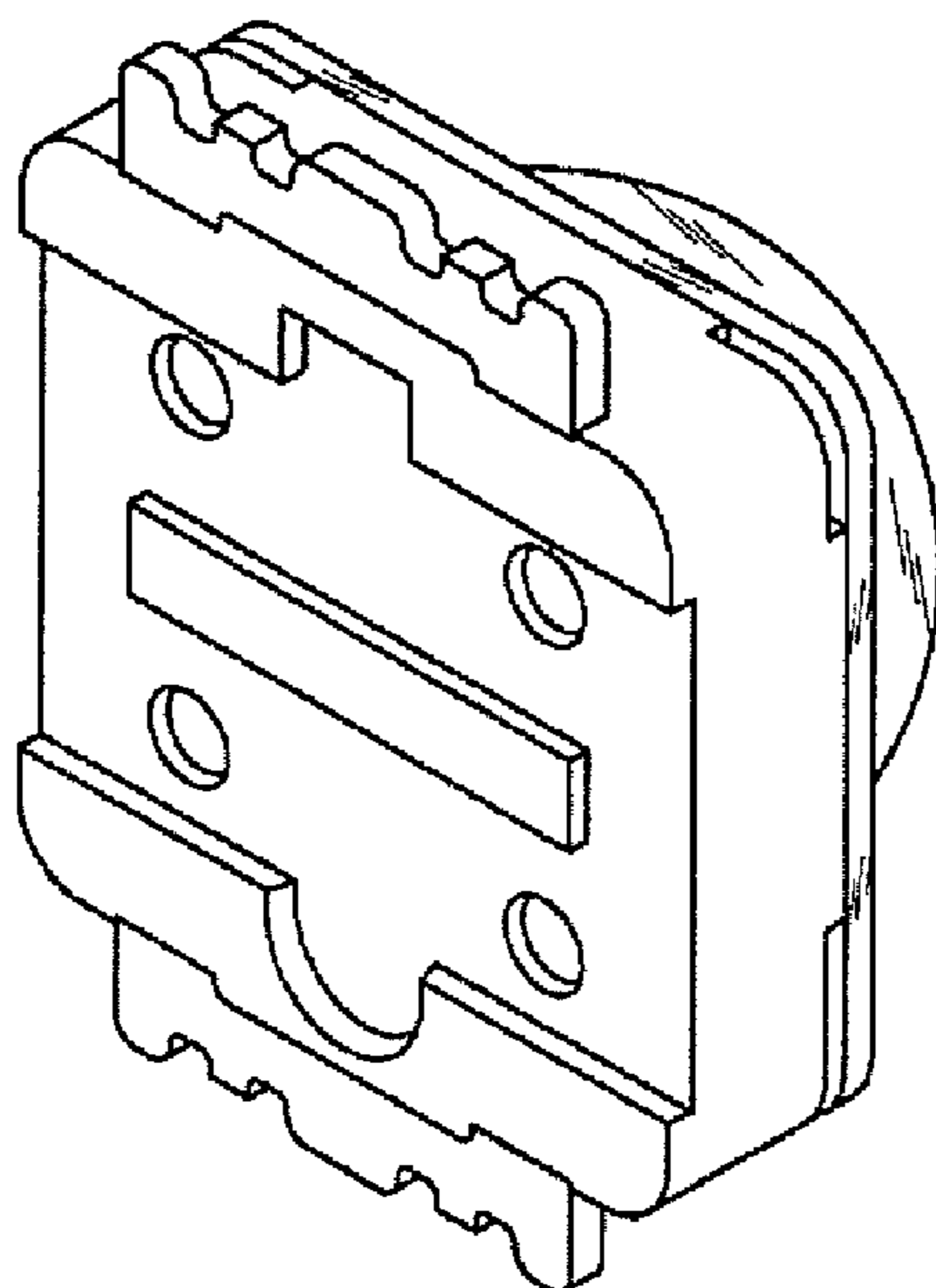

FIG. 2

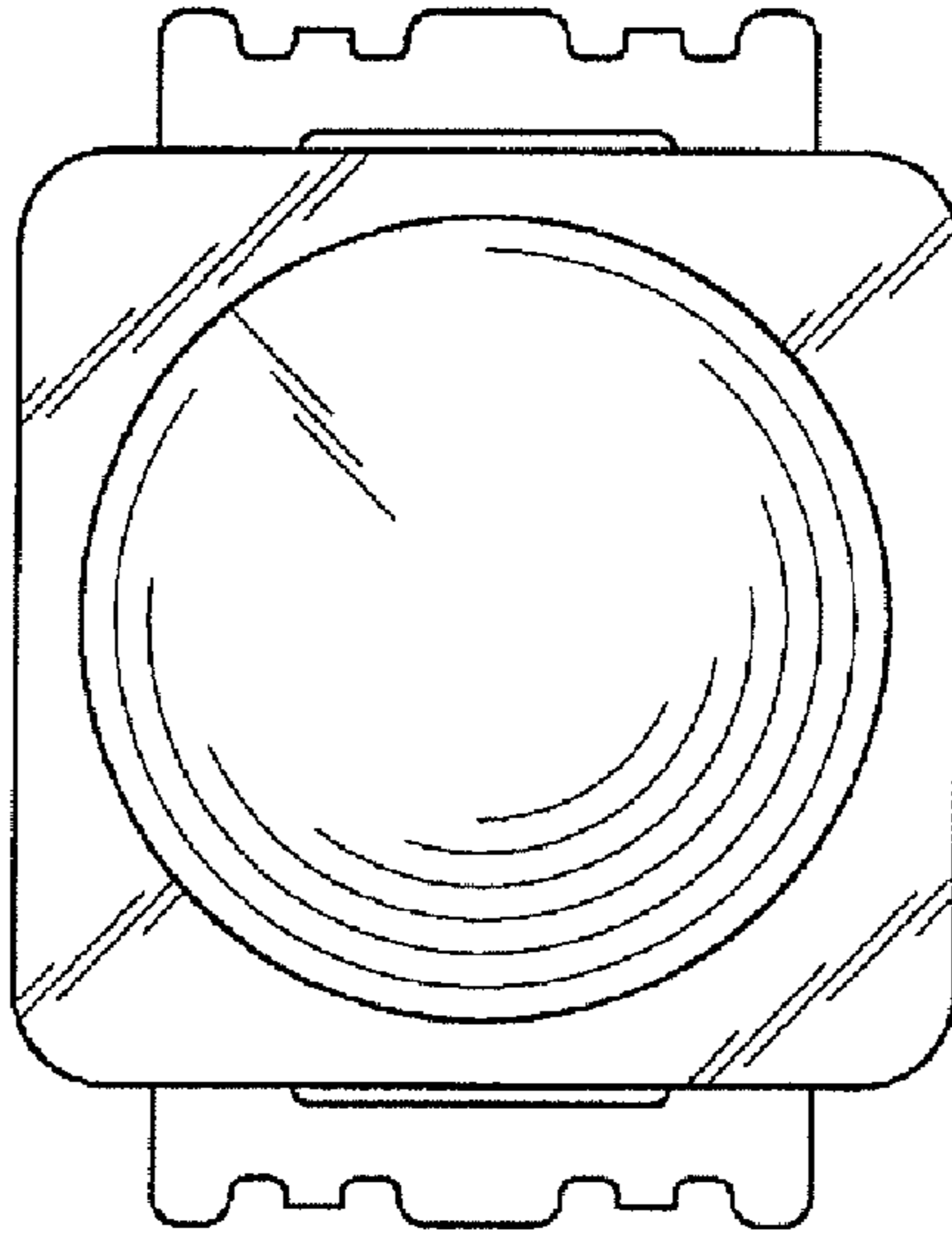

FIG. 3

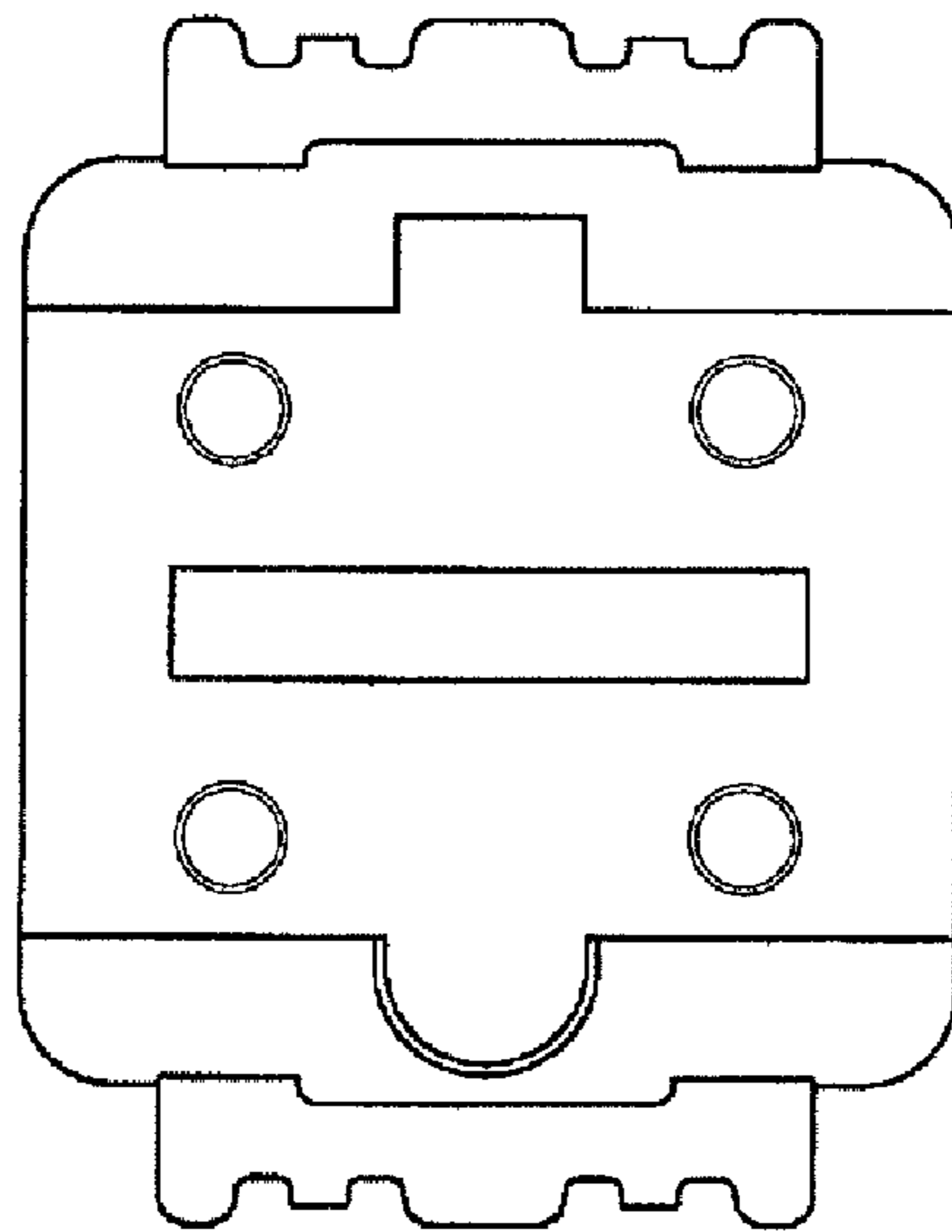

FIG. 4

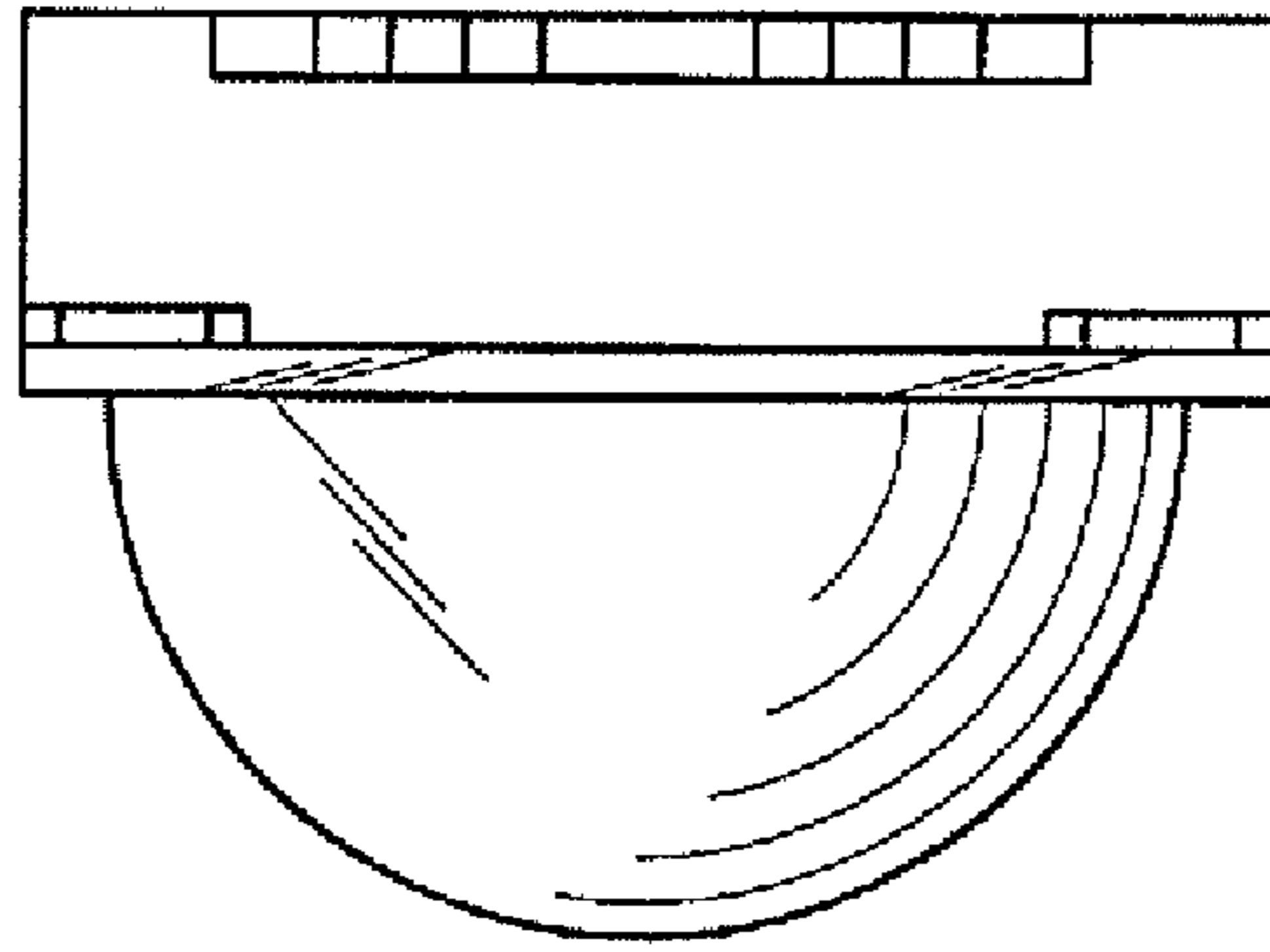

FIG. 5

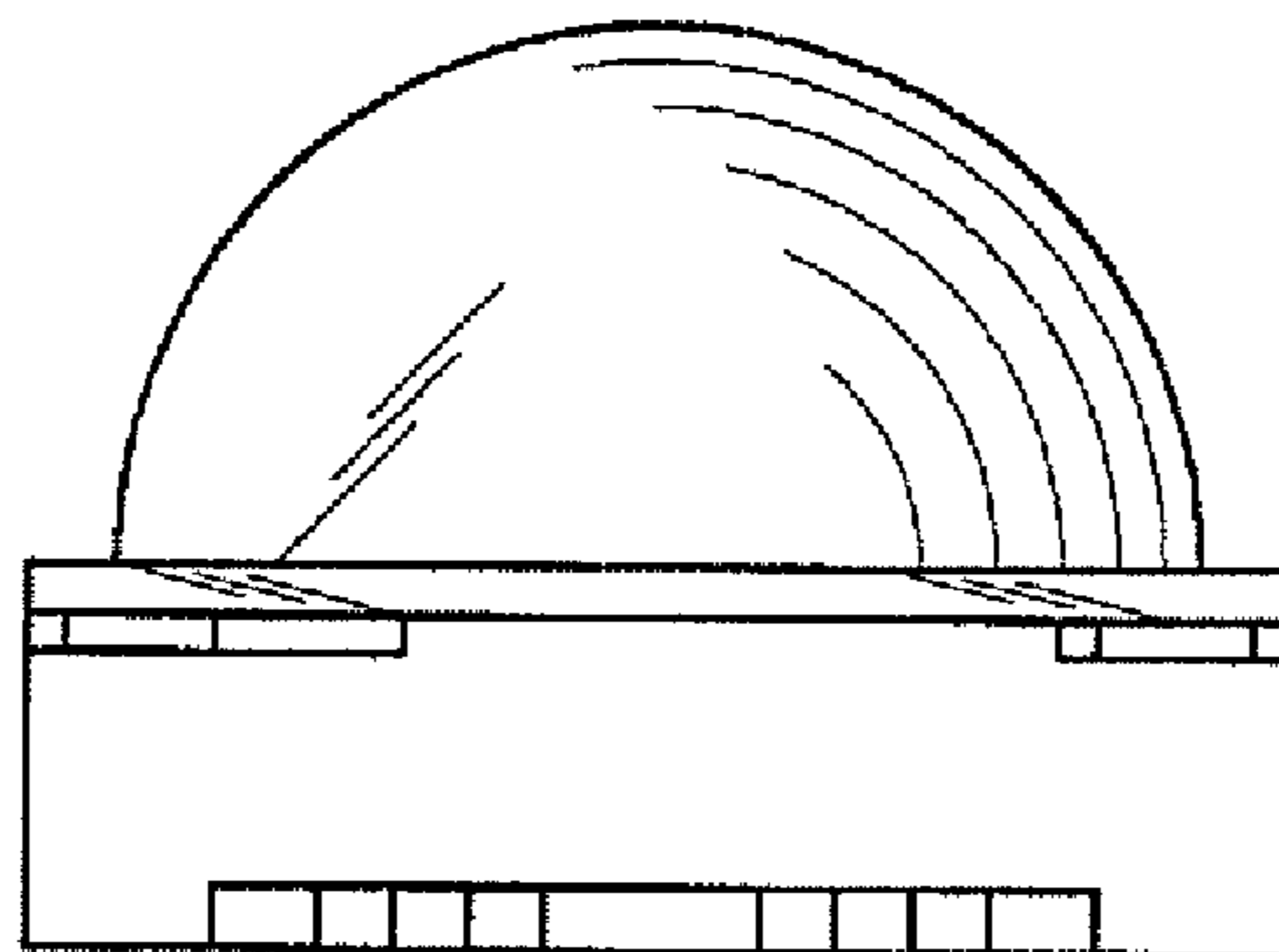

FIG. 6

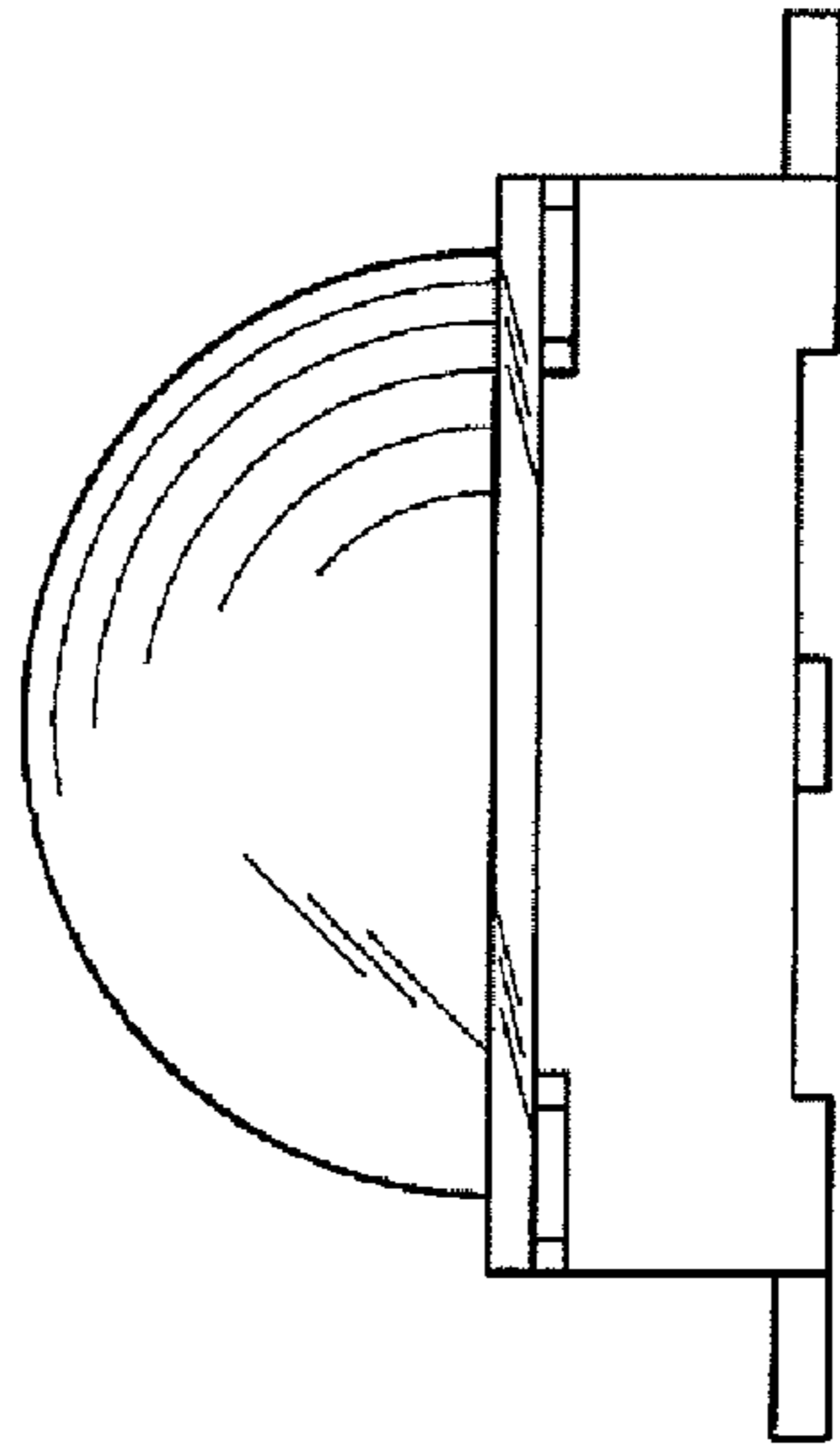

FIG. 7

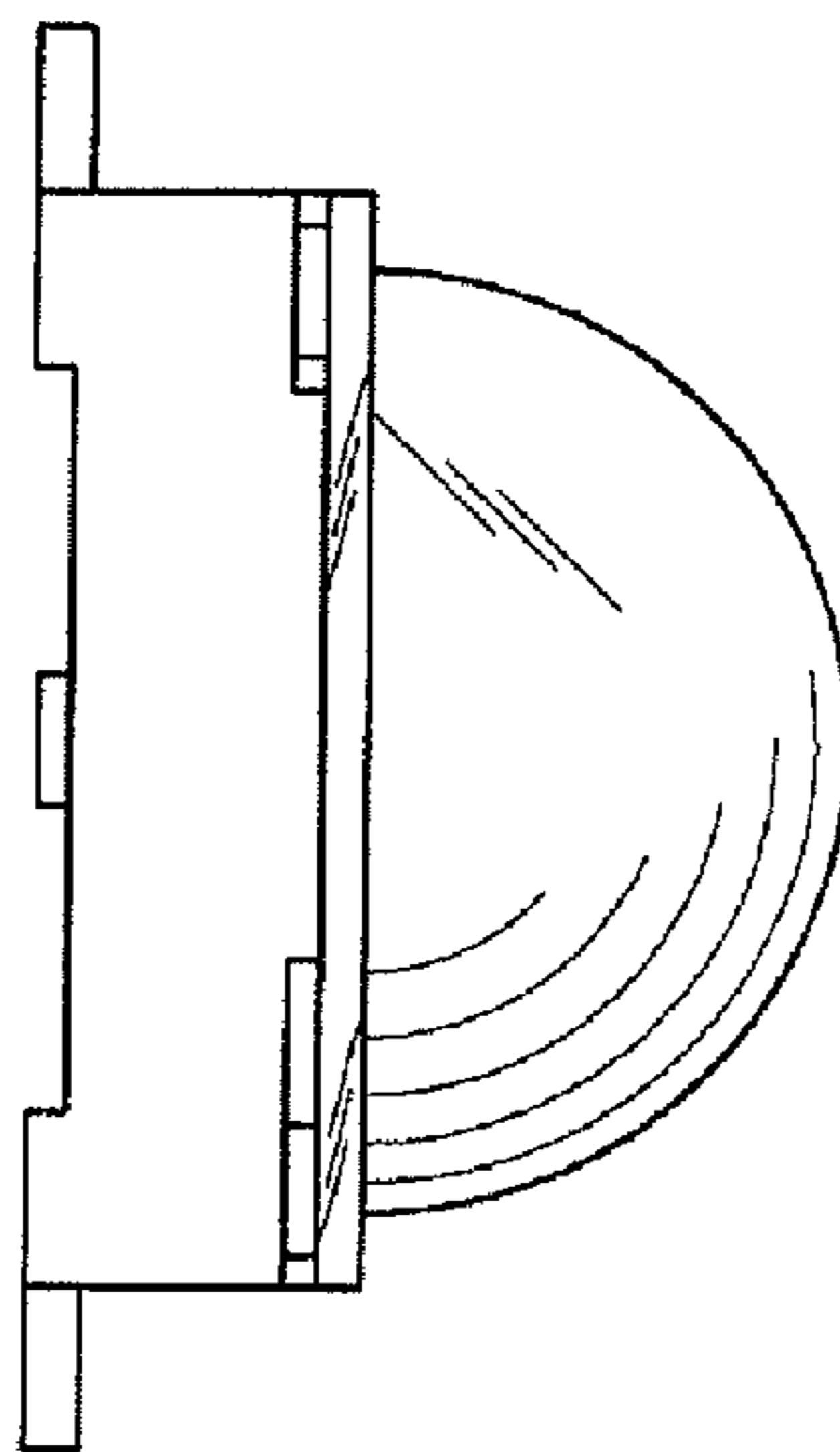

FIG. 8

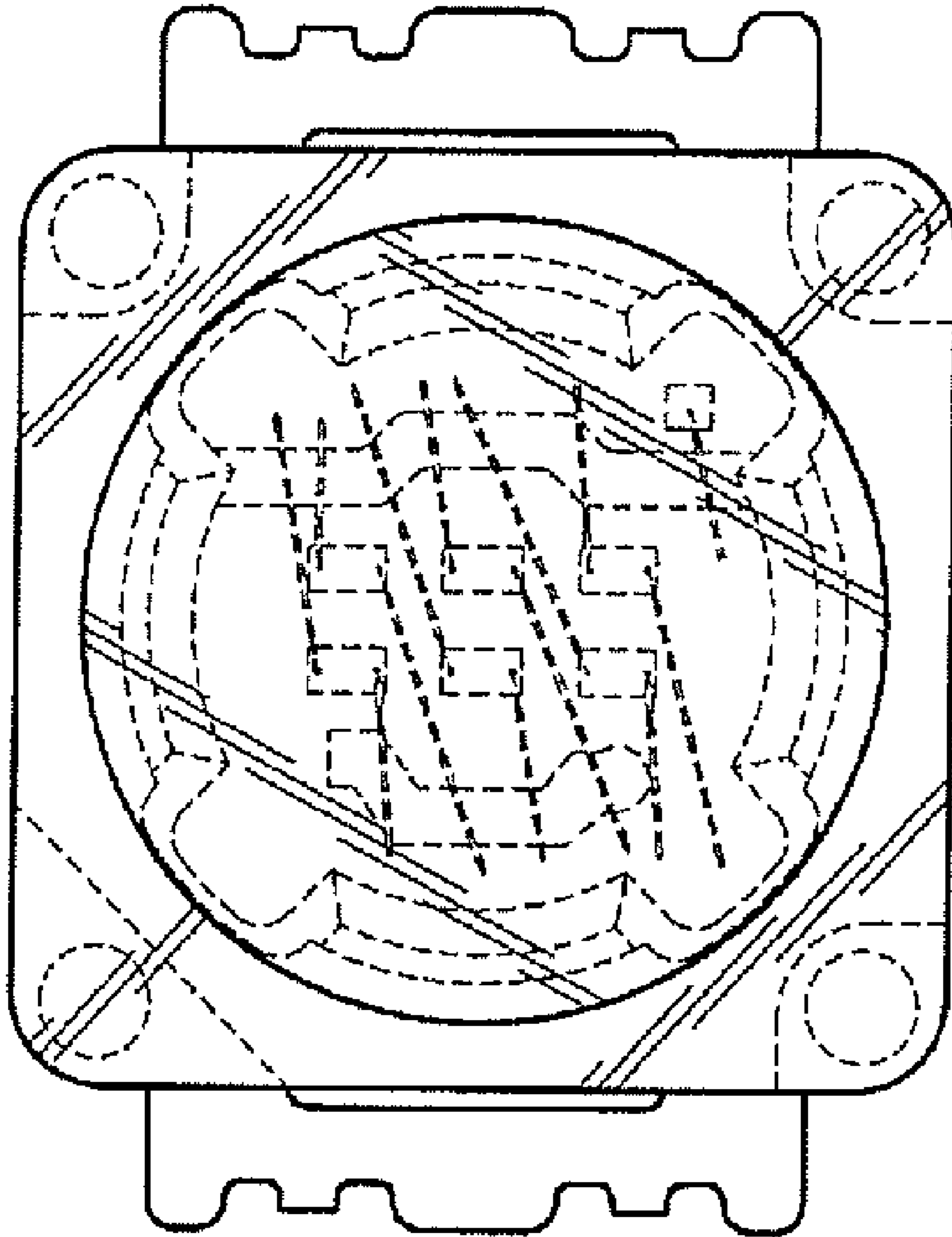

FIG. 9