



US00D584363S

(12) **United States Design Patent**
Gordon

(10) **Patent No.:** **US D584,363 S**
(45) **Date of Patent:** **** Jan. 6, 2009**

(54) **BANNER APPARATUS FOR VEHICLE TRAILER HITCH RECEIVER**

2006/0156600 A1 7/2006 Barker
2006/0218835 A1 10/2006 Chafin

(76) Inventor: **Richard Gordon**, 36 Bud Field Dr.,
Palm Coast, FL (US) 32137

* cited by examiner

(**) Term: **14 Years**

Primary Examiner—Caron Veynar
Assistant Examiner—Mary Ann Calabrese
(74) *Attorney, Agent, or Firm*—Quick Patents, Inc.; Kevin Prince

(21) Appl. No.: **29/298,941**

(22) Filed: **Dec. 14, 2007**

(57) **CLAIM**

(51) **LOC (9) Cl.** **20-03**

(52) **U.S. Cl.** **D20/43; D20/41; D12/400**

(58) **Field of Classification Search** D20/10,
D20/17, 19, 41-43, 99; 40/538, 541, 584,
40/588-591, 603, 604, 606.01, 606.03, 606.13-606.16,
40/607.03, 607.04, 607.08, 607.09, 607.11,
40/607.12, 610, 611.01, 611.05-611.07,
40/611.13, 612, 617, 618; D10/109; D11/166,
D11/182; D12/223, 400; 81/23; 116/28 R,
116/173, 174; 248/160, 188.7, 219.4, 220.21,
248/431; 280/816; 340/425.5; 473/173

I claim the ornamental design for a banner apparatus for vehicle trailer hitch receiver, as shown and described.

See application file for complete search history.

DESCRIPTION

(56) **References Cited**

U.S. PATENT DOCUMENTS

4,880,195	A *	11/1989	Lepley	248/219.4
5,089,803	A *	2/1992	Bohn	340/425.5
5,388,794	A *	2/1995	Wolff	248/219.4
5,441,267	A *	8/1995	Alder	473/173
D362,465	S *	9/1995	Gallemore, II	D20/41
D424,961	S *	5/2000	Dolfin	D10/109
6,430,855	B1 *	8/2002	Gertz et al.	40/607.04
6,557,483	B2	5/2003	Nathan		
D538,353	S *	3/2007	Spennare	D20/43
D564,595	S *	3/2008	Barrett	D20/29

FIG. 1 is a perspective view of a banner apparatus for vehicle trailer hitch receiver, illustrating the invention displaying a tall banner, showing my new design;
FIG. 2 is a left-side elevational view of the invention, illustrating the invention displaying the tall banner;
FIG. 3 is a right-side elevational view of the invention, illustrating the invention displaying the tall banner;
FIG. 4 is a front elevational view of the invention;
FIG. 5 is a rear elevational view of the invention;
FIG. 6 is a top plan view of the invention;
FIG. 7 is a bottom plan view of the invention; and,
FIG. 8 is a right-side elevational view of the invention, in an alternate position of use illustrating the invention displaying a short banner.

The broken lines showing a vehicle in FIG. 1 and a banner in FIGS. 1, 2, 3, and 8 are included for the purpose of illustrating the invention in use and form no part of the claimed design.

1 Claim, 3 Drawing Sheets

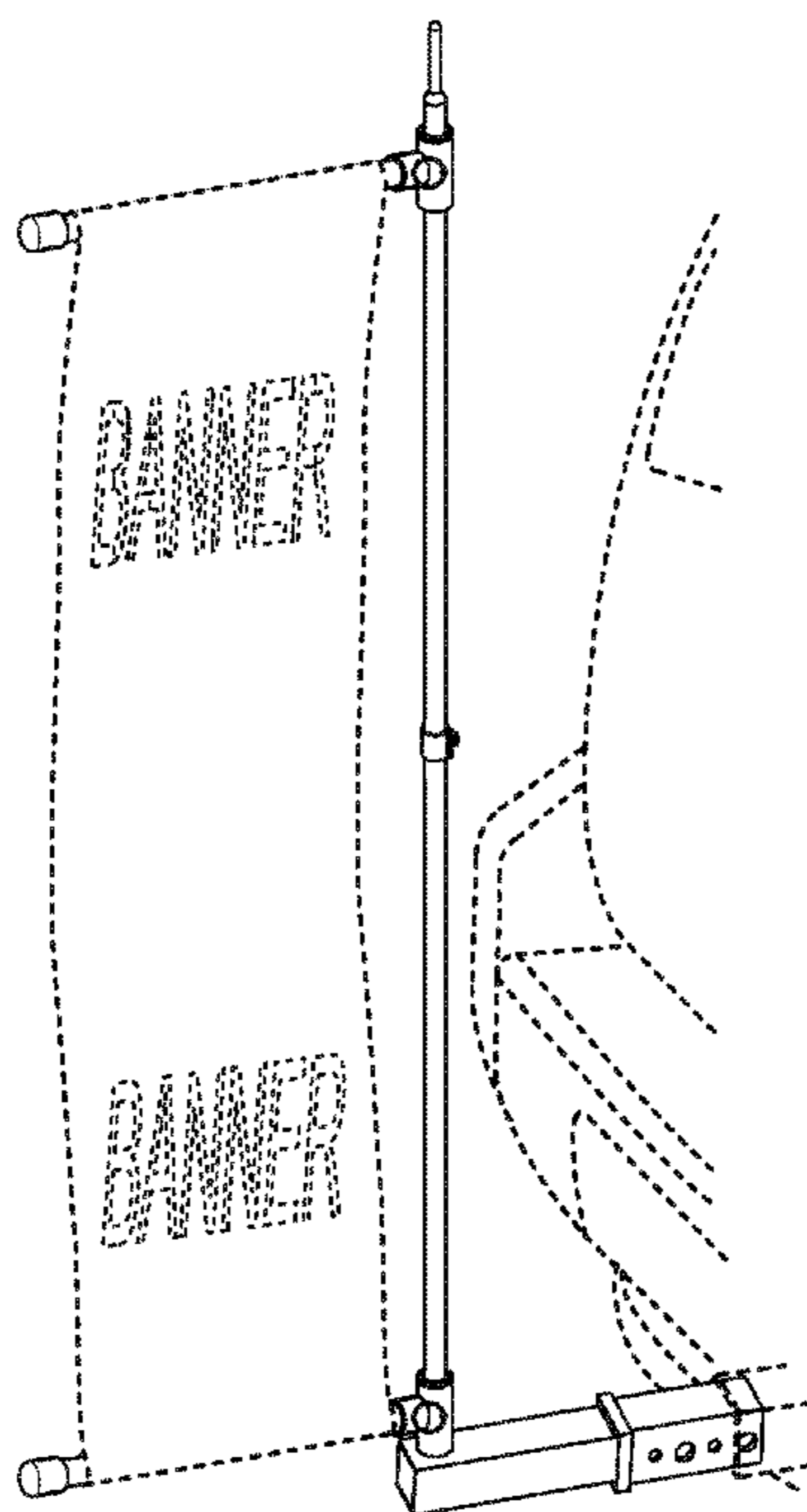

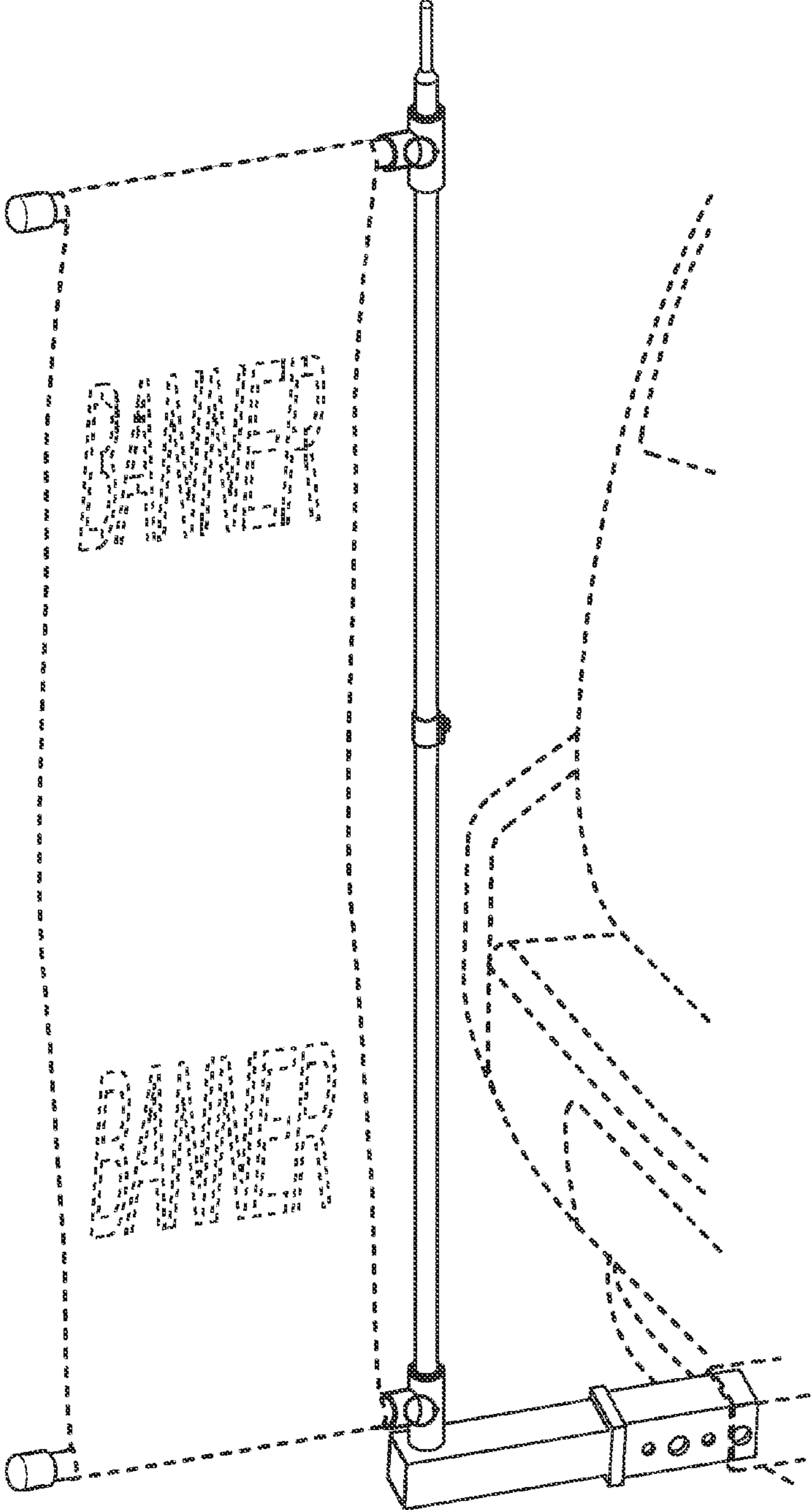

FIG. 1

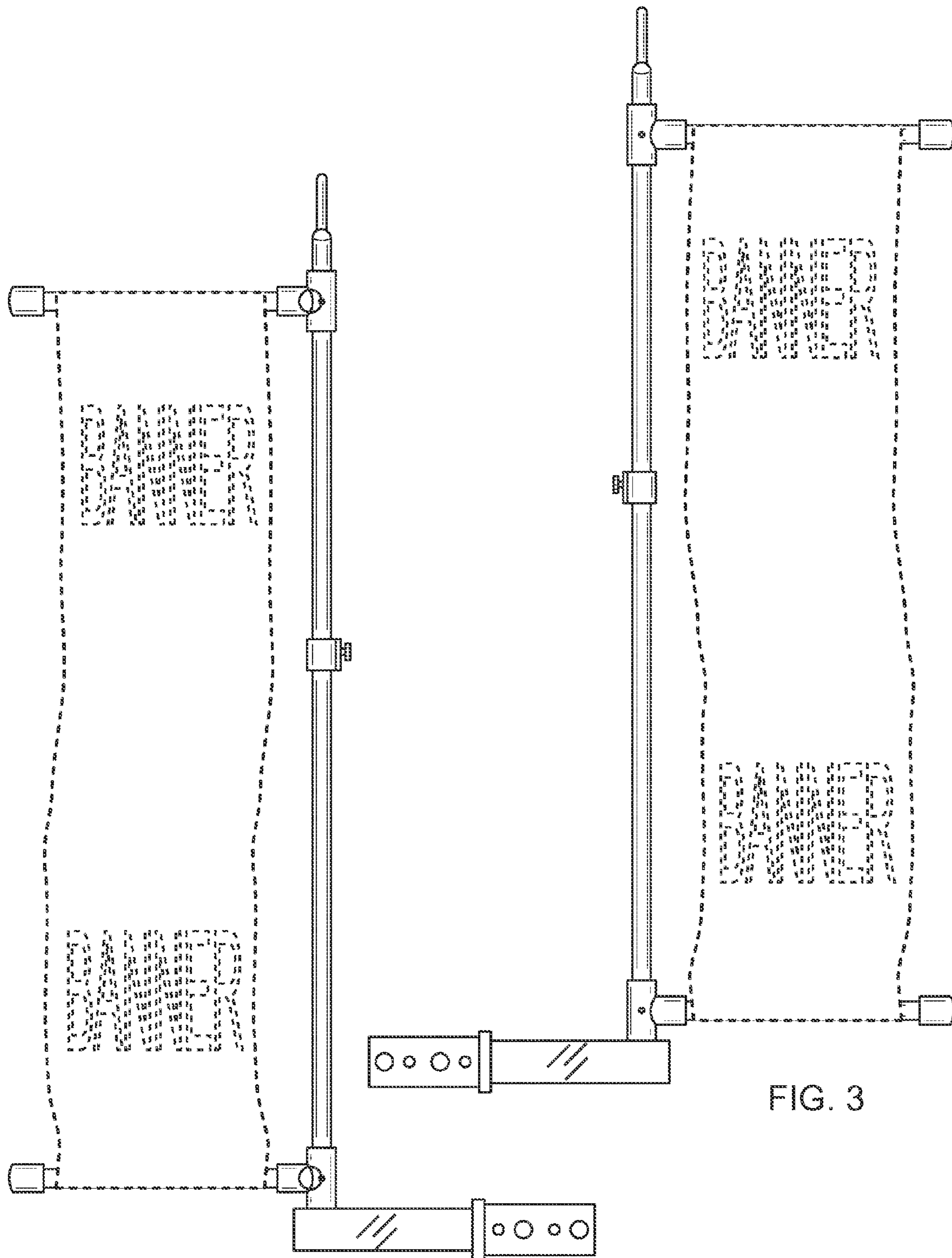

FIG. 2

FIG. 3

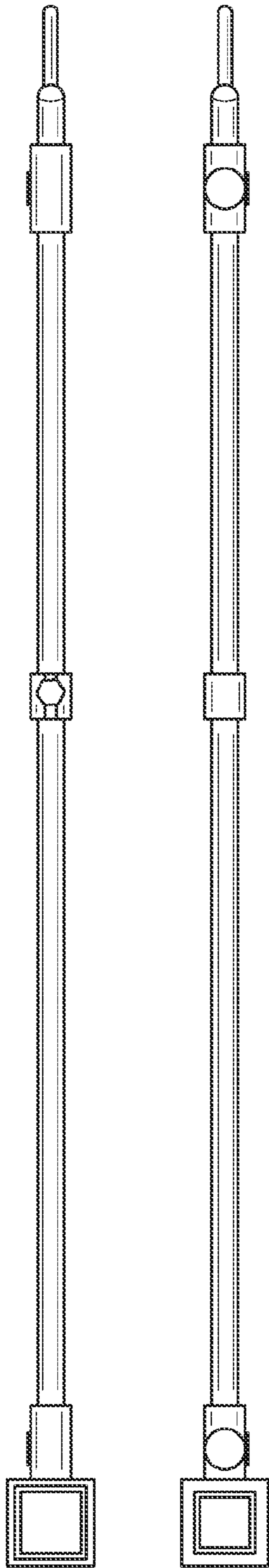

FIG. 4

FIG. 5

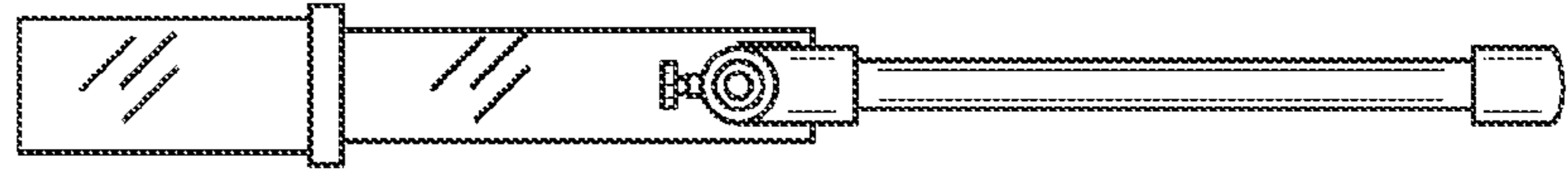

FIG. 6

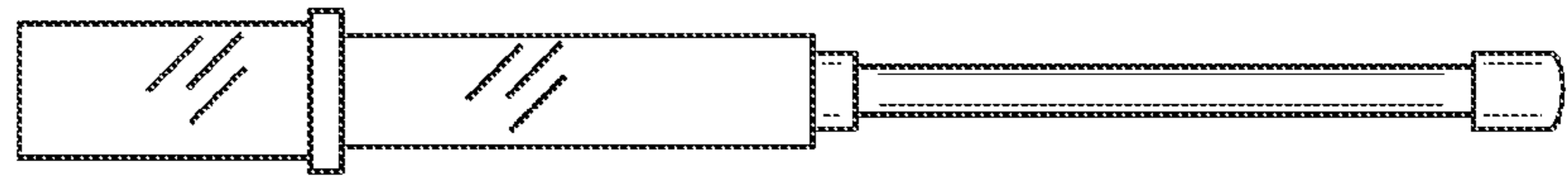

FIG. 7

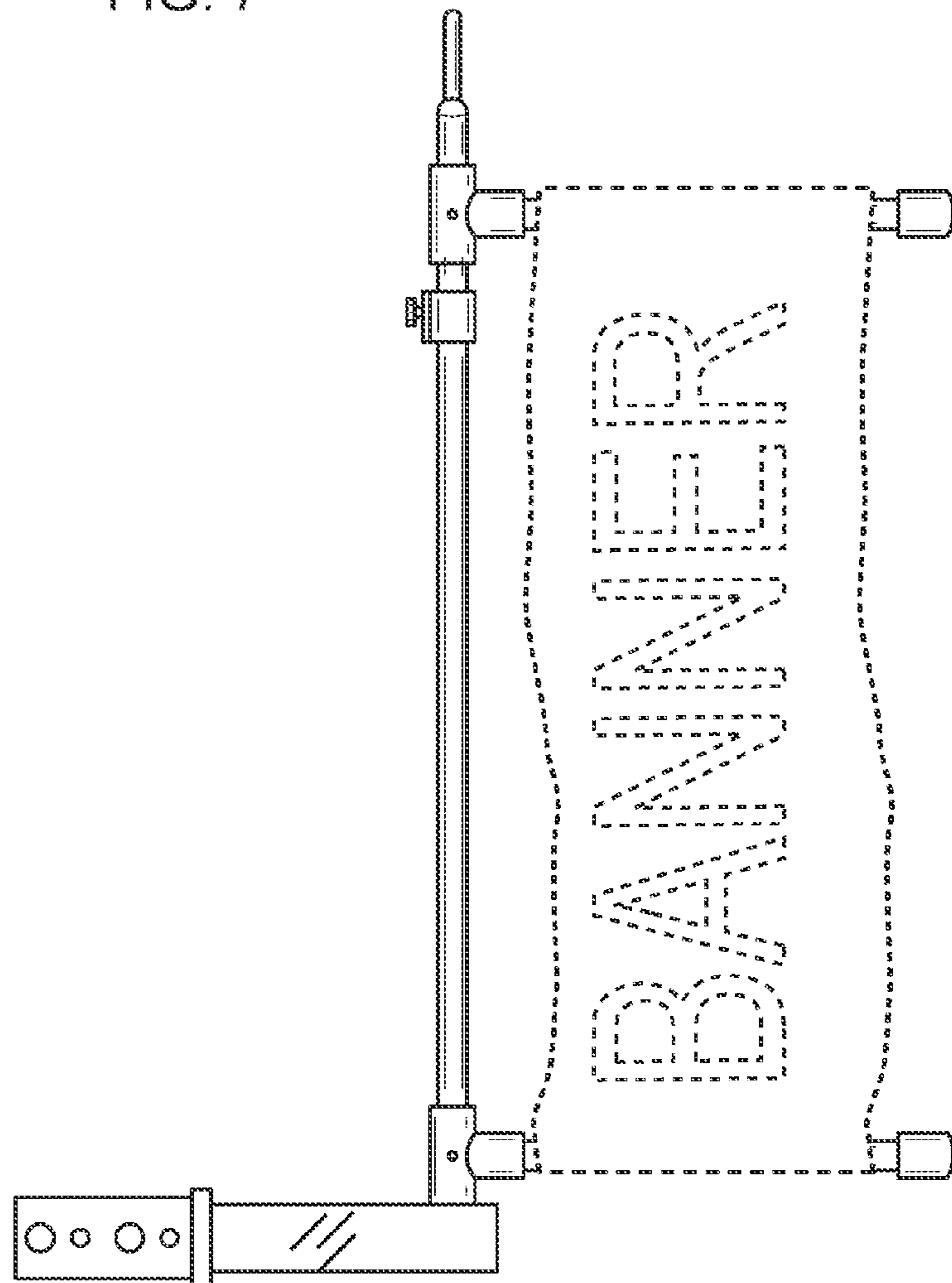

FIG. 8