



US00D584210S

(12) **United States Design Patent**
Baum

(10) **Patent No.:** **US D584,210 S**
(45) **Date of Patent:** **** Jan. 6, 2009**

(54) **FRONT FACE OF A VEHICLE WHEEL**

(75) Inventor: **Stephan Baum**, Olching (DE)

(73) Assignee: **Bayerische Motoren Werke Aktiengesellschaft**, Munich (DE)

(**) Term: **14 Years**

(21) Appl. No.: **29/287,330**

(22) Filed: **Jul. 24, 2007**

(30) **Foreign Application Priority Data**

Jan. 25, 2007 (DE) 40700466

(51) **LOC (9) Cl.** **12-16**

(52) **U.S. Cl.** **D12/211**

(58) **Field of Classification Search** D12/204-213;
301/37.101, 64.101, 65, 64.201
See application file for complete search history.

(56) **References Cited**

U.S. PATENT DOCUMENTS

- D348,243 S * 6/1994 Echazabal et al. D12/211
- D350,932 S * 9/1994 Echazabel et al. D12/211
- D438,503 S * 3/2001 Syring D12/211
- D480,035 S * 9/2003 Frohlich D12/211
- D493,404 S * 7/2004 Baum D12/211

- D500,726 S * 1/2005 Hettler D12/211
- D506,172 S * 6/2005 Pfeiffer D12/211
- D516,989 S 3/2006 Baum
- D525,932 S 8/2006 Hettler
- D528,495 S * 9/2006 Truebsbach D12/211
- D548,162 S * 8/2007 Baum D12/211
- D558,117 S * 12/2007 Baum D12/211

* cited by examiner

Primary Examiner—Stacia Cadmus

(74) *Attorney, Agent, or Firm*—Crowell & Moring LLP

(57) **CLAIM**

The ornamental design for a front face of a vehicle wheel, as shown and described.

DESCRIPTION

This application is related to the following co-pending application: Application Ser. No. 29/268,411, filed Nov. 7, 2006, entitled "Front Face of a Vehicle Wheel."

FIG. 1 is a front view of a front face of a vehicle wheel according to my novel design; and,

FIG. 2 is a perspective view thereof.

The broken lines are for illustrative purposes only and form no part of the claimed design.

1 Claim, 1 Drawing Sheet

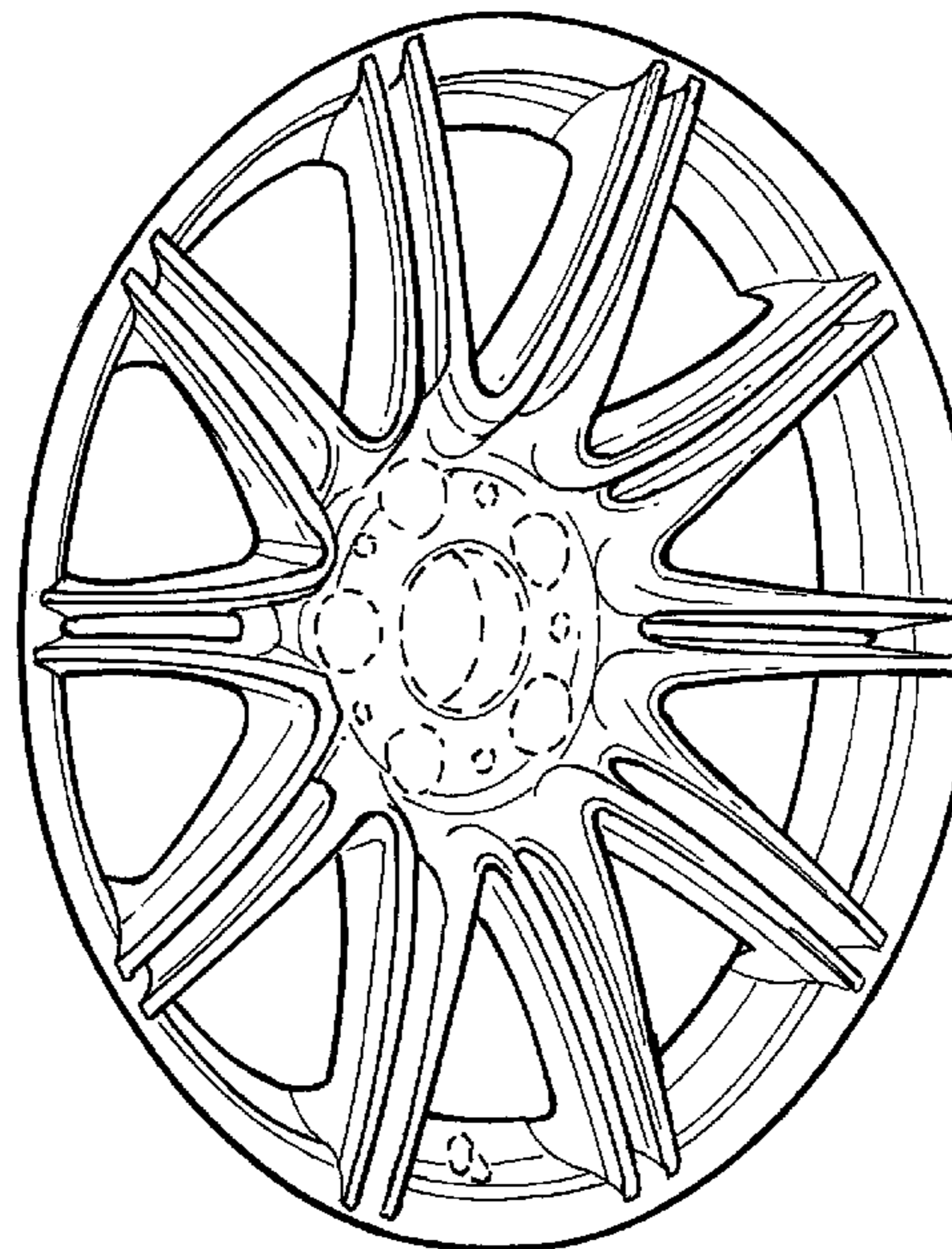
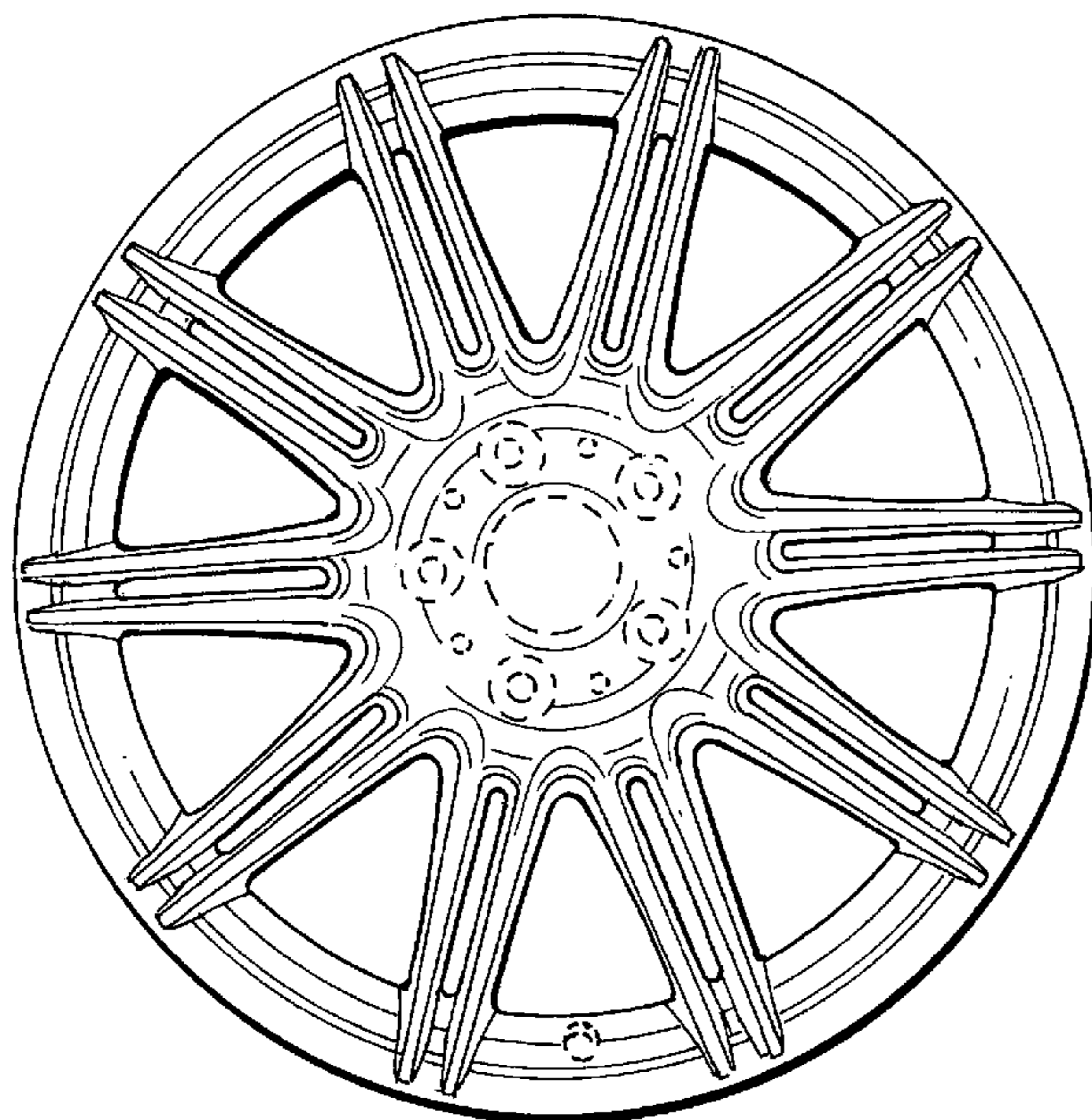

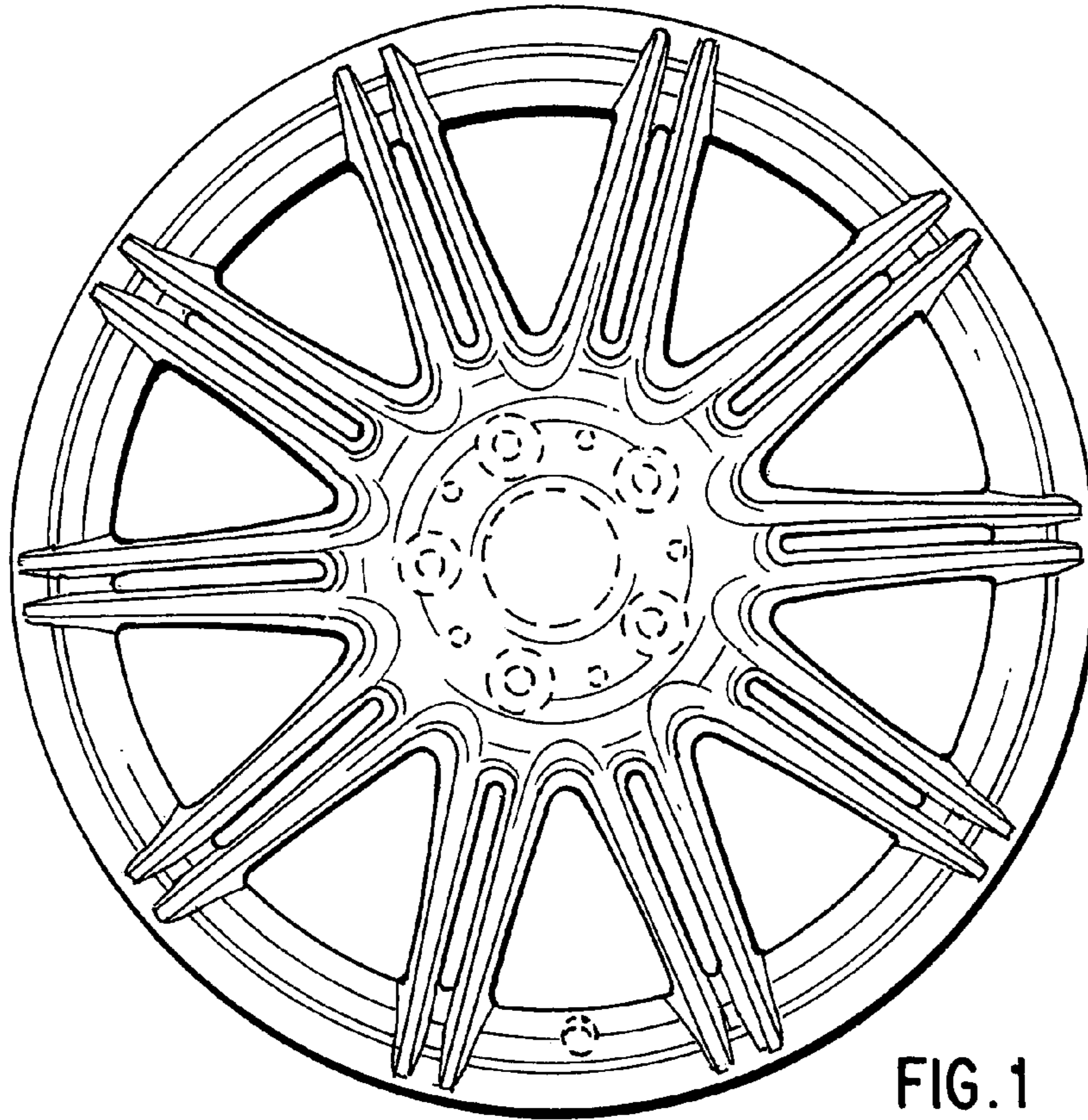

FIG. 1

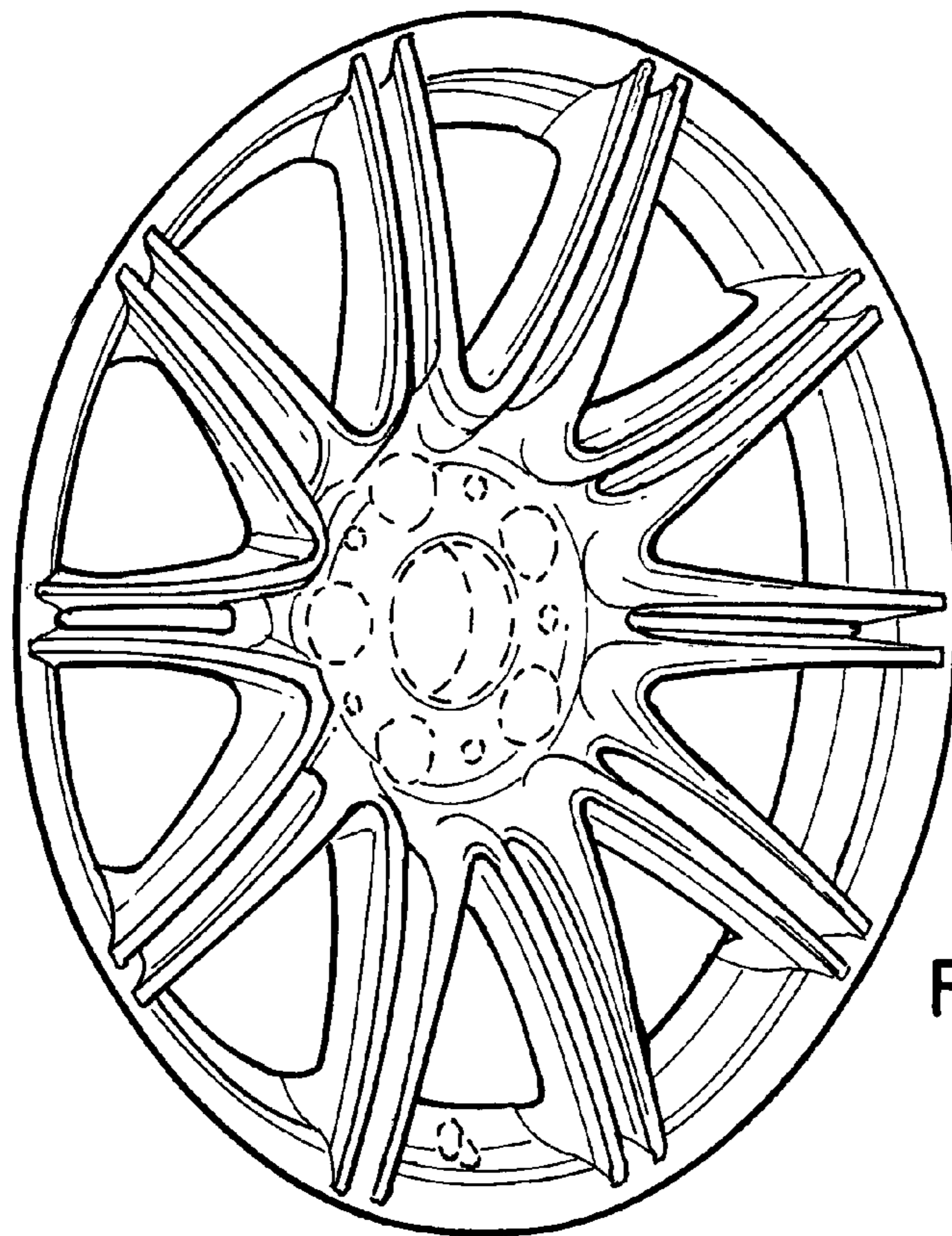

FIG. 2