



US00D584074S

(12) **United States Design Patent**
Gadzinski et al.

(10) **Patent No.:** **US D584,074 S**
(45) **Date of Patent:** **** Jan. 6, 2009**

(54) **WORK STATION**

(75) Inventors: **Ryan D. Gadzinski**, Grand Rapids, MI (US); **Zoocy C. Chu**, Grand Rapids, MI (US)

(73) Assignee: **Synergy Product Development, Inc.**, Grand Rapids, MI (US)

(**) Term: **14 Years**

(21) Appl. No.: **29/298,870**

(22) Filed: **Dec. 14, 2007**

(51) **LOC (9) Cl.** **06-04**

(52) **U.S. Cl.** **D6/426**

(58) **Field of Classification Search** D6/480,
D6/469, 466, 449, 429, 426, 396, 300, 419,
D6/474, 464, 425; D7/601; D34/17; D28/73;
D20/10; D17/99; D14/307, 302, 130; 84/327;
312/194-196; 108/50.01, 92, 115, 116; 52/239
See application file for complete search history.

(56) **References Cited**

U.S. PATENT DOCUMENTS

D288,157 S *	2/1987	Sandor	D6/474
5,129,715 A	7/1992	Maynard		
5,460,101 A	10/1995	Garbutt et al.		

(Continued)

Primary Examiner—Cathron C Brooks

Assistant Examiner—Austin Murphy

(74) *Attorney, Agent, or Firm*—Barry C. Kane

(57) **CLAIM**

The ornamental design for a work station, as shown and described.

DESCRIPTION

FIG. 1 is an oblique view of one embodiment of the invention illustrating rotatable extensions at each end of the central work surface;

FIG. 2 is a front elevation view of the invention shown in FIG. 1;

FIG. 3 is a back elevation view of the invention shown in FIG. 1;

FIG. 4 is a side elevation view of the invention shown in FIG. 1;

FIG. 5 is an opposite side elevation view of the invention shown in FIG. 1;

FIG. 6 is a top view of the invention shown in FIG. 1;

FIG. 7 is a bottom view of the invention shown in FIG. 1;

FIG. 8 is an oblique view of the invention shown in FIG. 1 illustrating a fully rotated position of one extension of the work surface, the extension able to assume an angular position of rotation between that shown in FIG. 1 and FIG. 8;

FIG. 9 is a front view of the invention shown in FIG. 8;

FIG. 10 is a back elevation view of the invention shown in FIG. 8;

FIG. 11 is a side elevation view of the invention shown in FIG. 8;

FIG. 12 is an opposite side view of the invention shown in FIG. 8;

FIG. 13 is a top elevation view of the invention shown in FIG. 8;

FIG. 14 is a bottom view of the invention shown in FIG. 8;

FIG. 15 is an oblique view of the invention shown in FIG. 1 illustrating a fully rotated position of the opposite extension of the work surface, the extension able to assume an angular position of rotation between that shown in FIG. 1 and FIG. 15;

FIG. 16 is a front view of the invention shown in FIG. 15;

FIG. 17 is a back elevation view of the invention shown in FIG. 15;

FIG. 18 is a side elevation view of the invention shown in FIG. 15;

FIG. 19 is an opposite side view of the invention shown in FIG. 15;

FIG. 20 is a top elevation view of the invention shown in FIG. 15; and,

FIG. 21 is a bottom view of the invention shown in FIG. 15.

1 Claim, 18 Drawing Sheets



US D584,074 S

Page 2

U.S. PATENT DOCUMENTS

5,666,887	A	9/1997	Grabowski et al.	
D394,965	S *	6/1998	Fang	D6/474
5,791,751	A	8/1998	Meyer et al.	
5,970,662	A	10/1999	Corcorran et al.	
5,979,118	A	11/1999	Gortsema et al.	
6,012,788	A	1/2000	Marschand et al.	
6,024,427	A	2/2000	Underwood et al.	
6,027,093	A	2/2000	Reiher	
D424,772	S *	5/2000	Mullen	D34/17
D428,557	S *	7/2000	Chang	D6/422
D429,580	S *	8/2000	Janowitz	D6/426
6,145,448	A	11/2000	Marschand et al.	
D435,367	S *	12/2000	Tzeng	D6/480
D435,368	S *	12/2000	Tzeng	D6/480
6,247,772	B1	6/2001	Tuttle et al.	
D455,576	S *	4/2002	Tzeng	D6/426
6,378,255	B1	4/2002	Eich et al.	
D456,633	S *	5/2002	Chang	D6/426
D457,012	S *	5/2002	Chang	D6/426
D457,347	S *	5/2002	Luong	D6/426
D459,110	S *	6/2002	Chang	D6/426
6,428,094	B1	8/2002	Ruiter	
D462,194	S *	9/2002	Wang	D6/425
6,453,826	B1	9/2002	Fookes et al.	
D464,212	S *	10/2002	Chen	D6/425
D464,213	S *	10/2002	Chang	D6/426
D464,502	S *	10/2002	Chen	D6/425
D469,270	S *	1/2003	Hawang	D6/425
D474,043	S *	5/2003	Chang	D6/426
D474,921	S *	5/2003	Chen	D6/426
6,637,352	B1	10/2003	Thode et al.	
D487,852	S *	3/2004	Chang	D6/426
D500,214	S *	12/2004	Chang	D6/426
6,848,369	B1	2/2005	King et al.	
6,895,869	B2	5/2005	Lai	
D508,344	S *	8/2005	Hwang	D6/425
6,926,278	B2	8/2005	Bibi	
D512,851	S *	12/2005	Chang	D6/425
7,032,523	B2	4/2006	Forslund et al.	
7,263,932	B2	9/2007	Winter et al.	

* cited by examiner

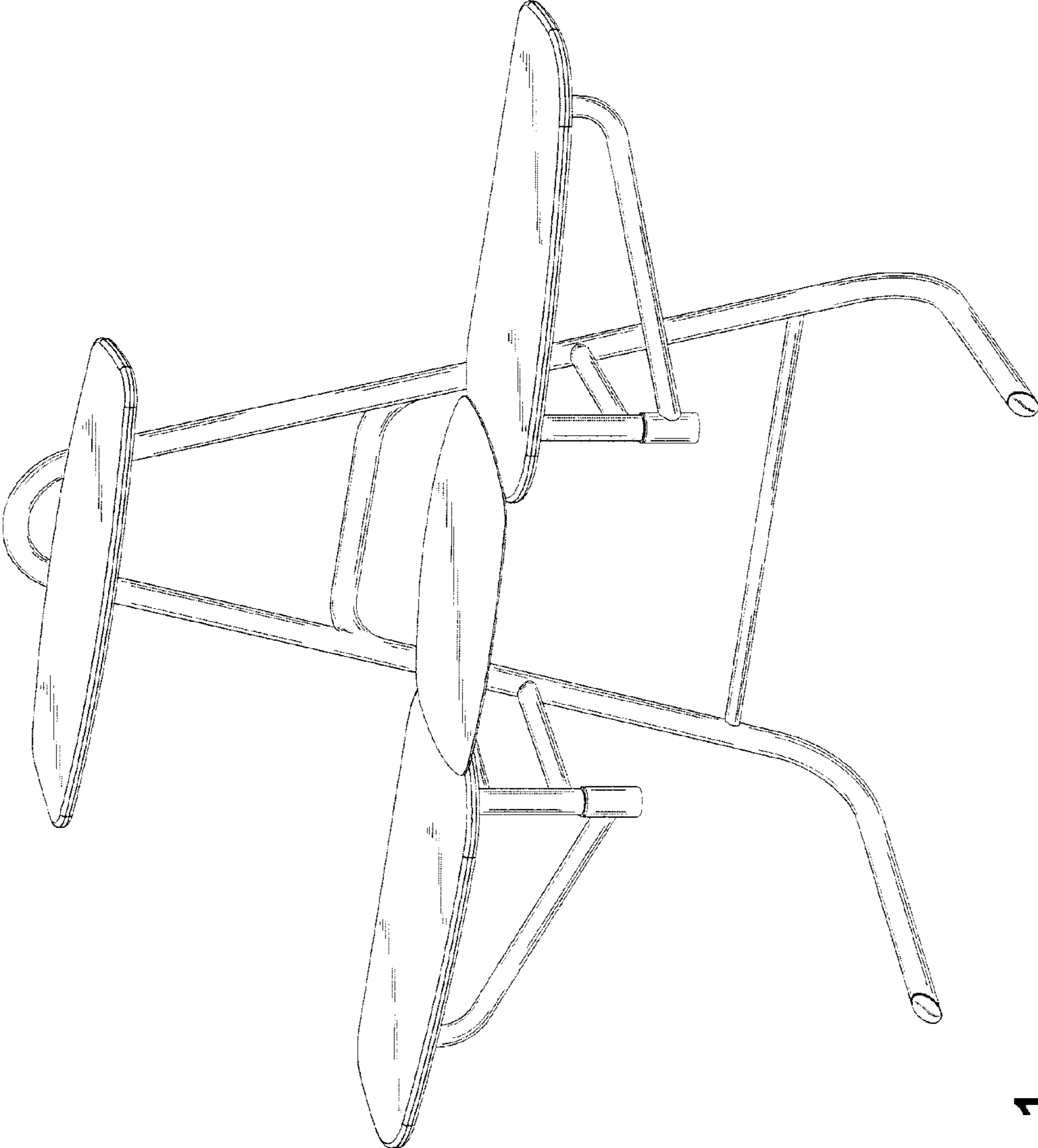

Fig. 1

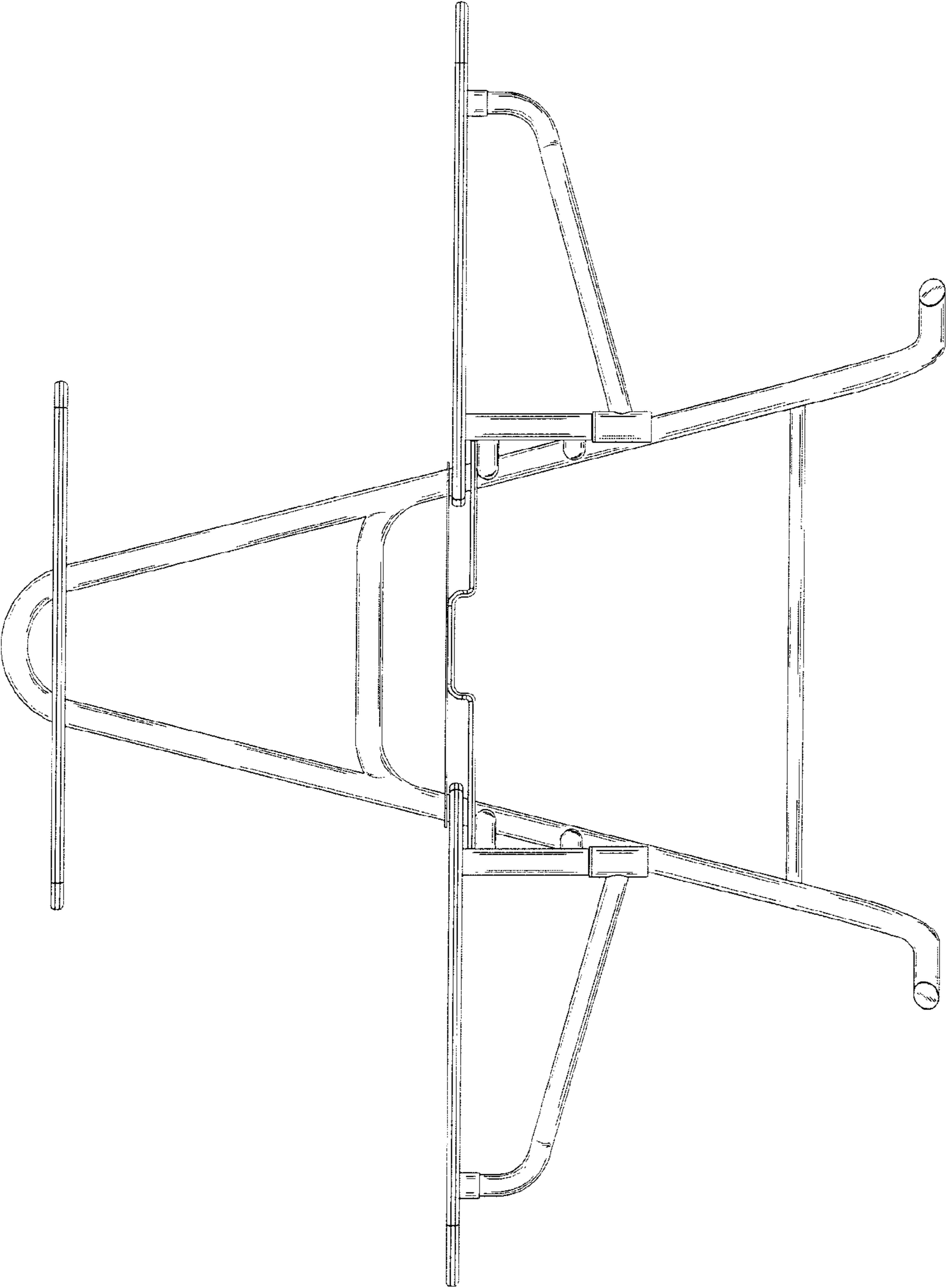

Fig. 2

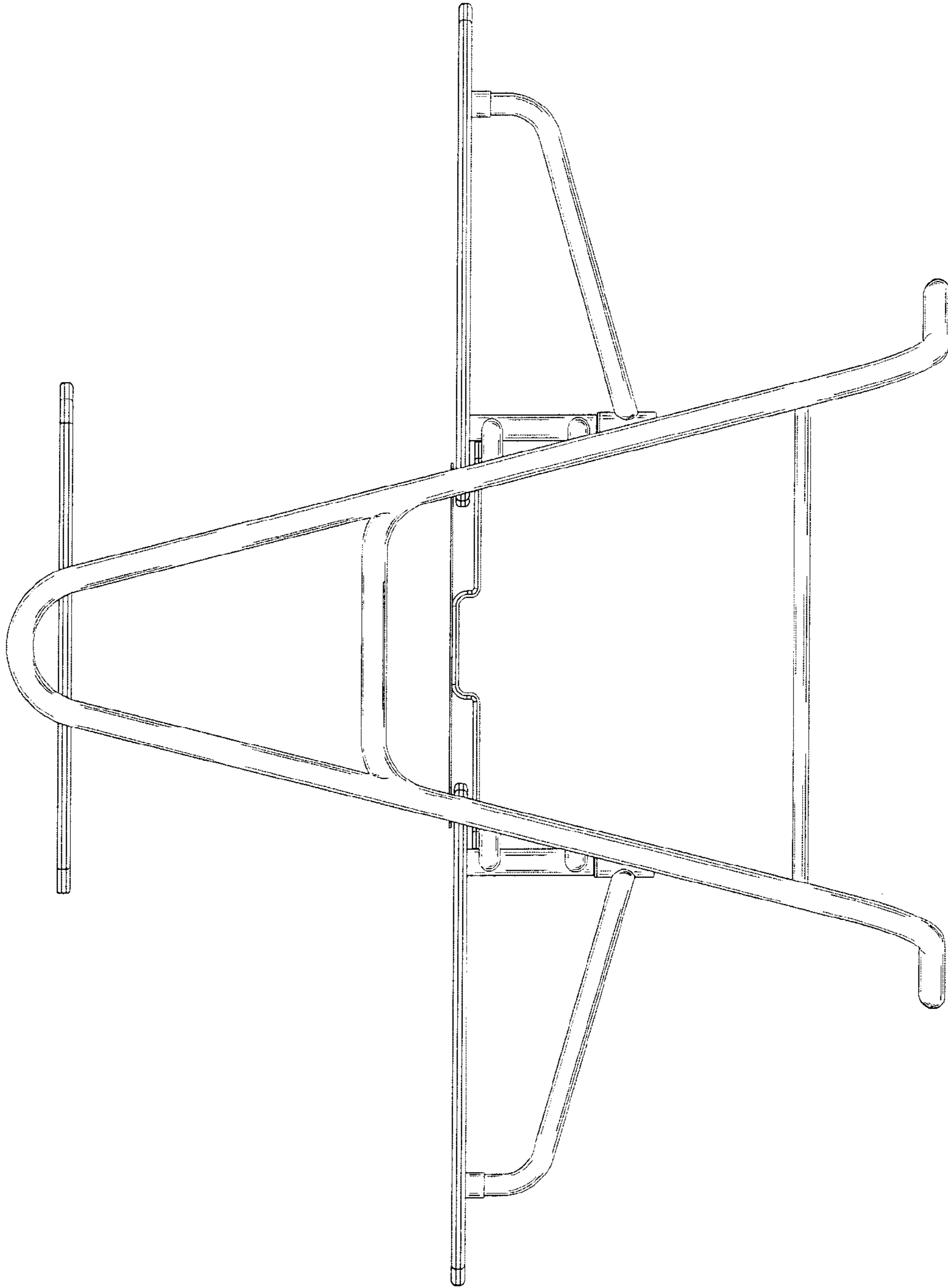

Fig. 3

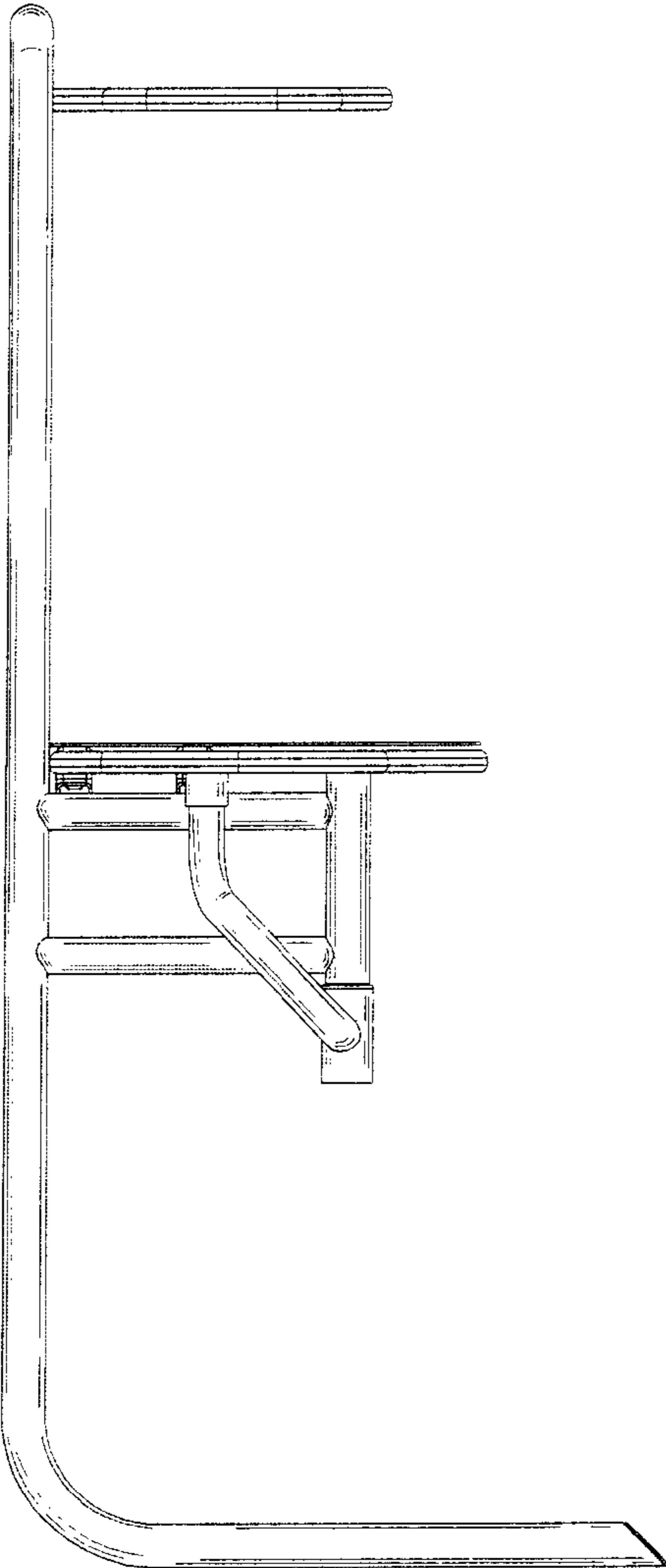

Fig. 4

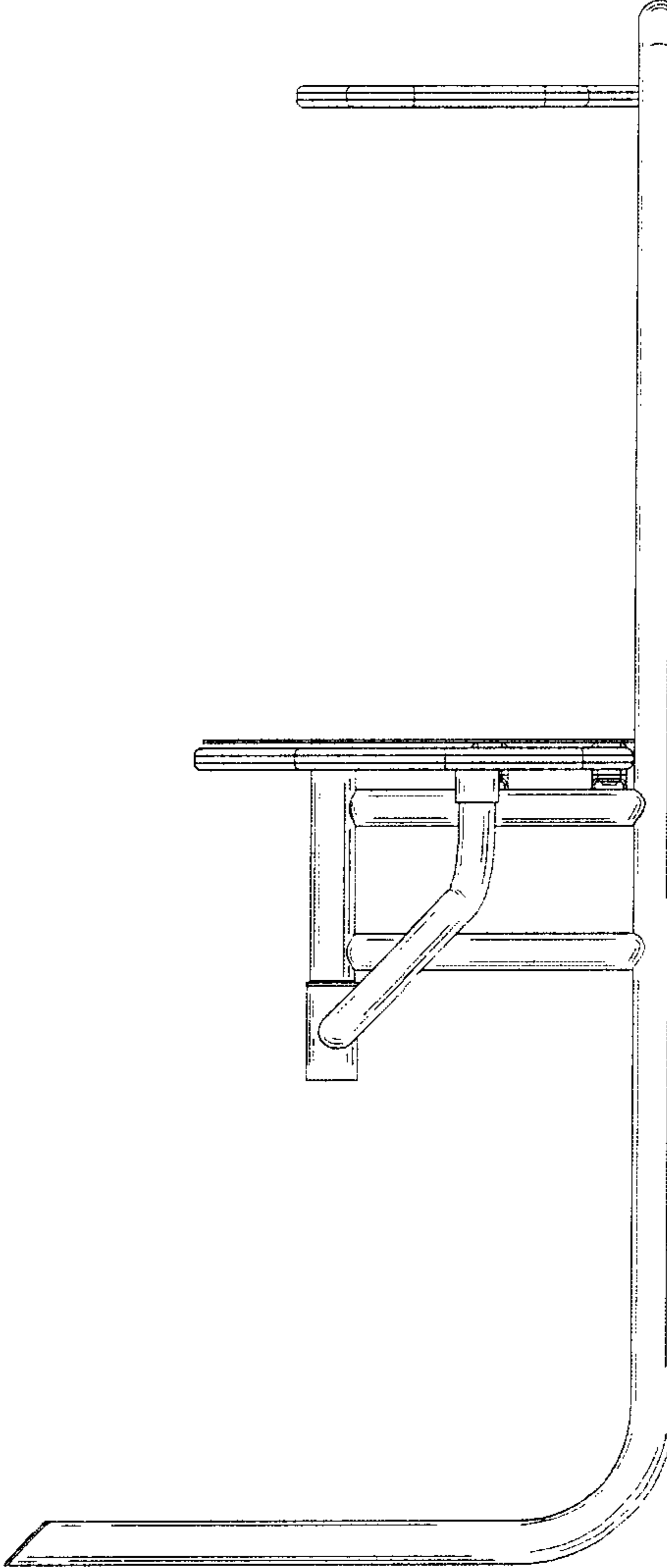

Fig. 5

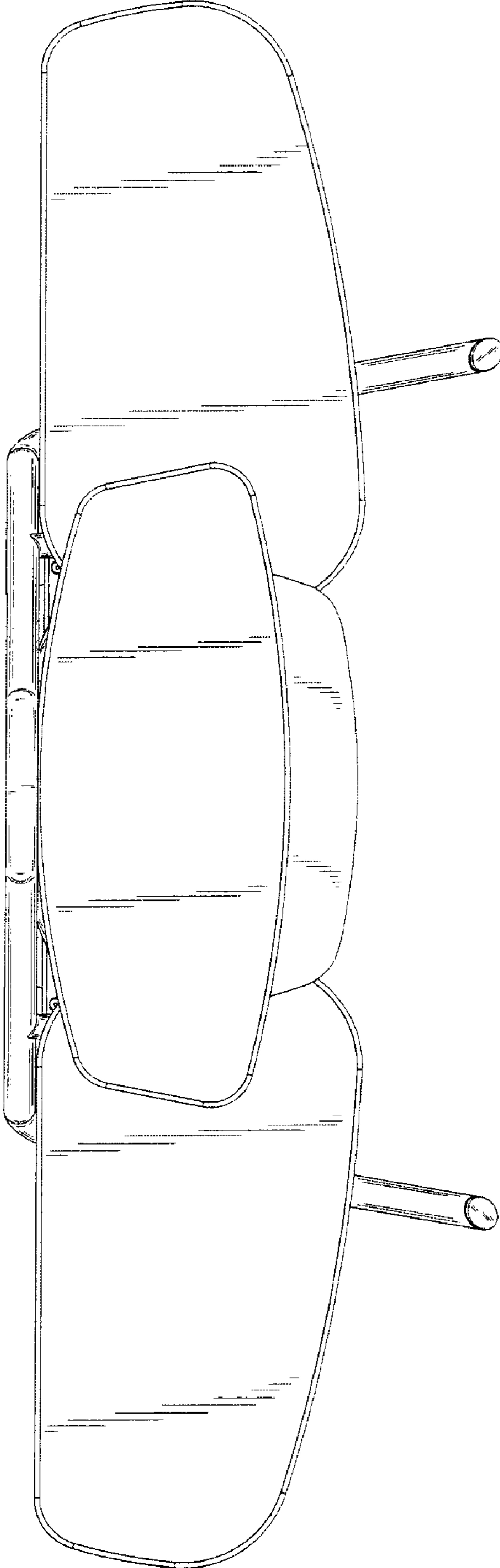

Fig. 6

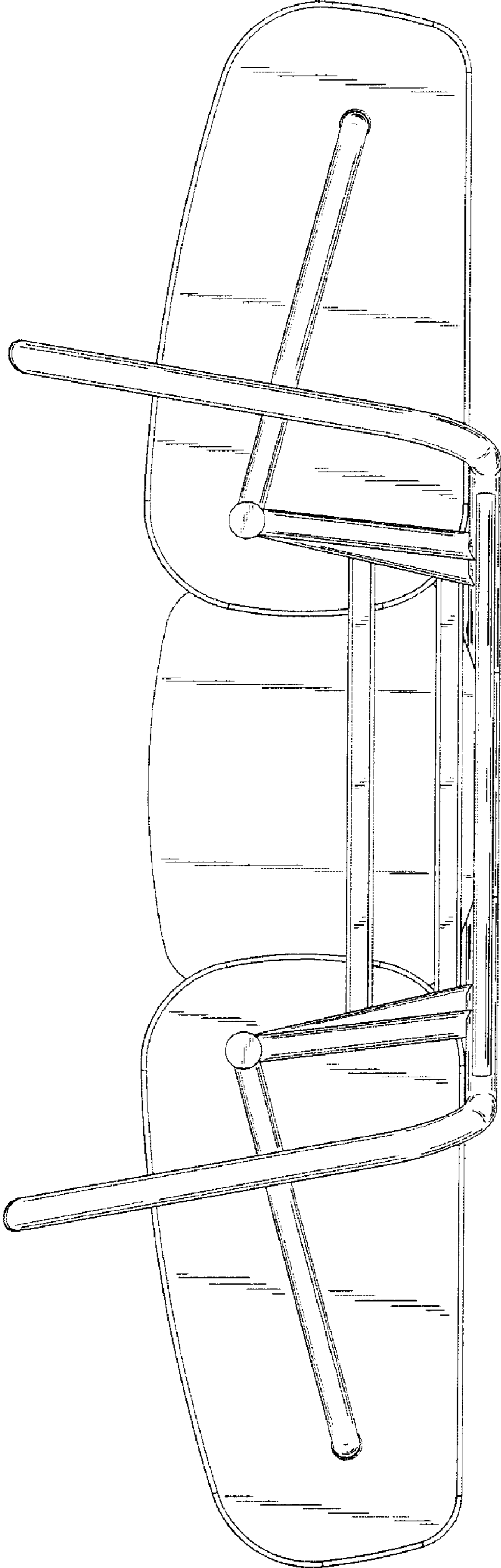

Fig. 7

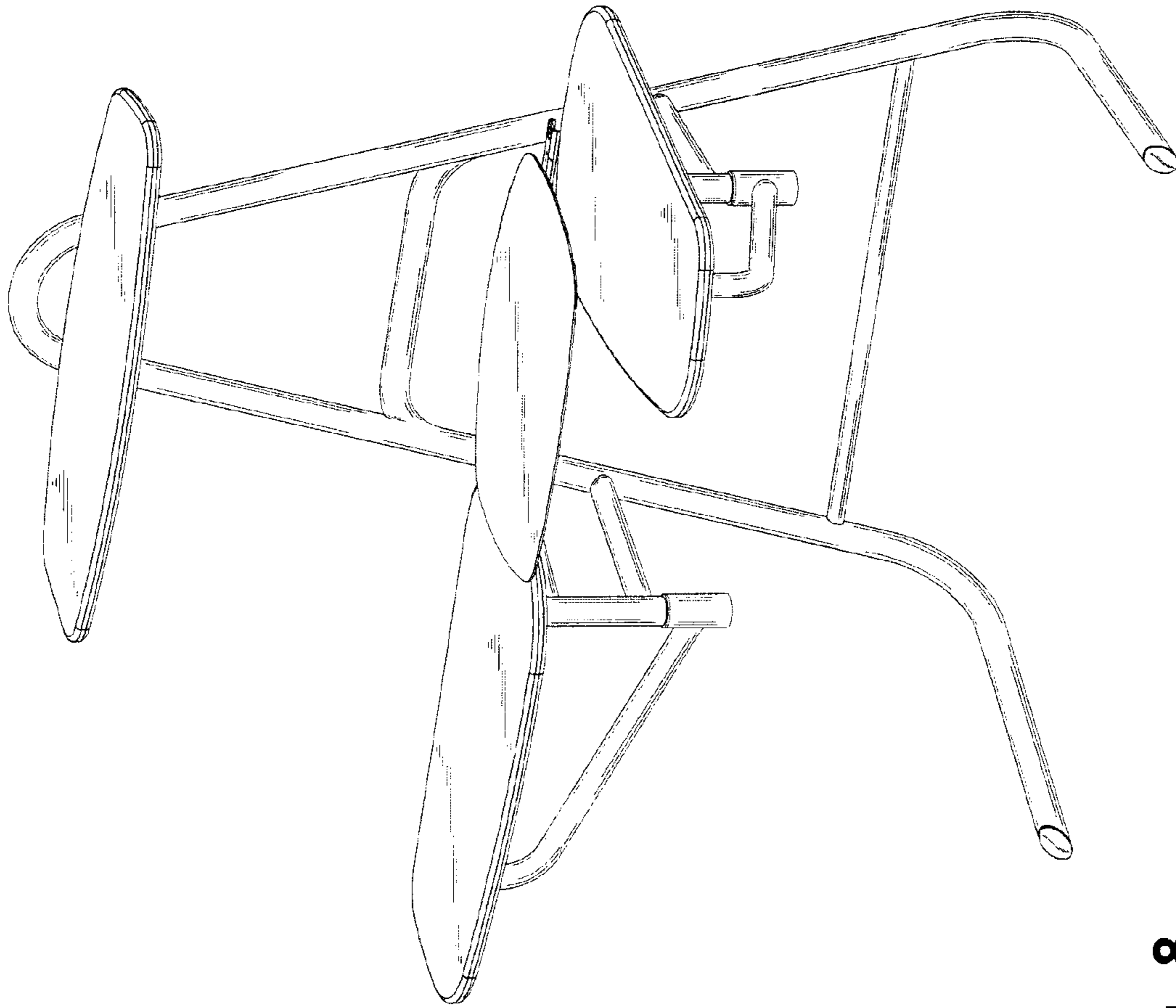

Fig. 8

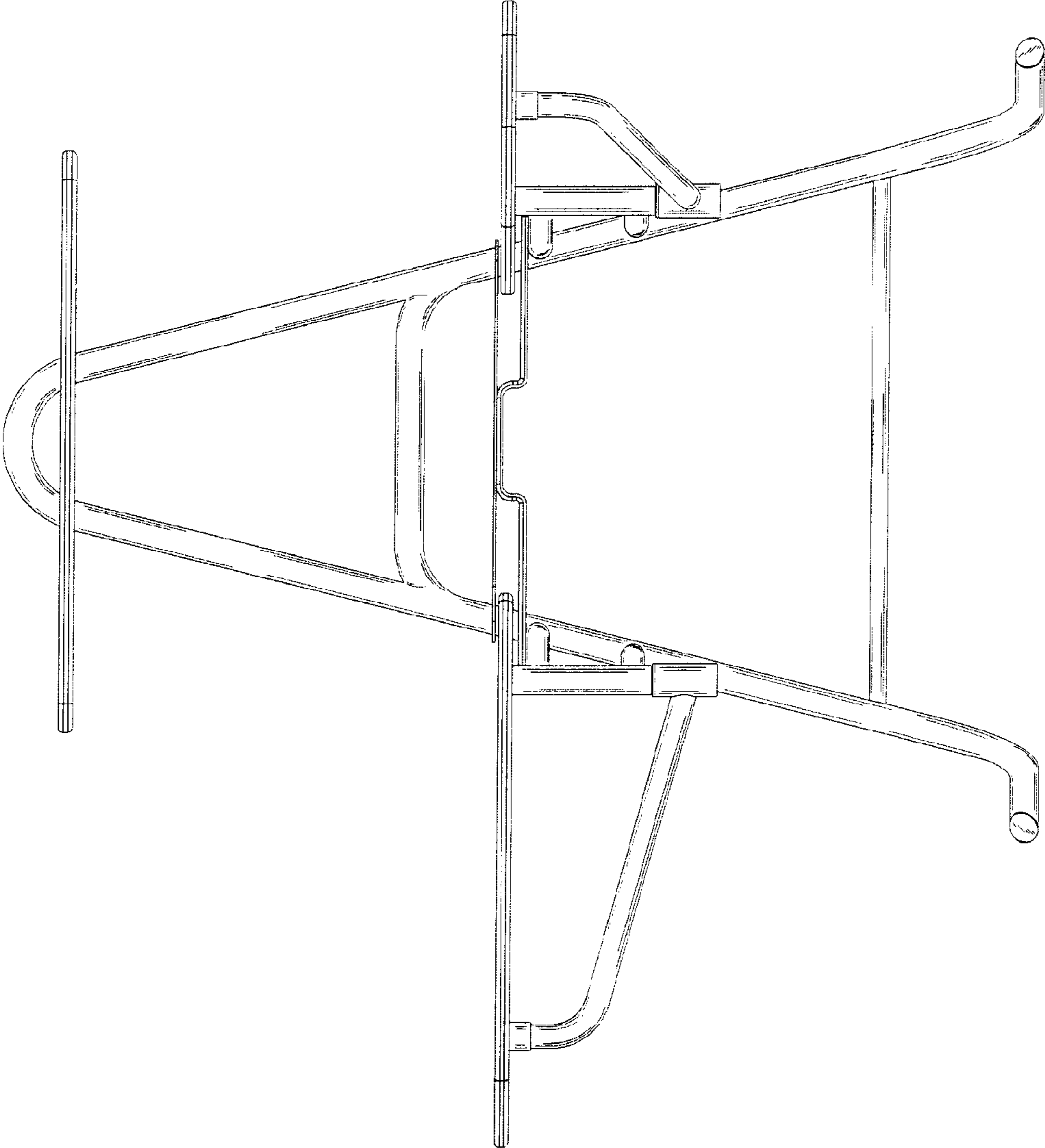

Fig. 9

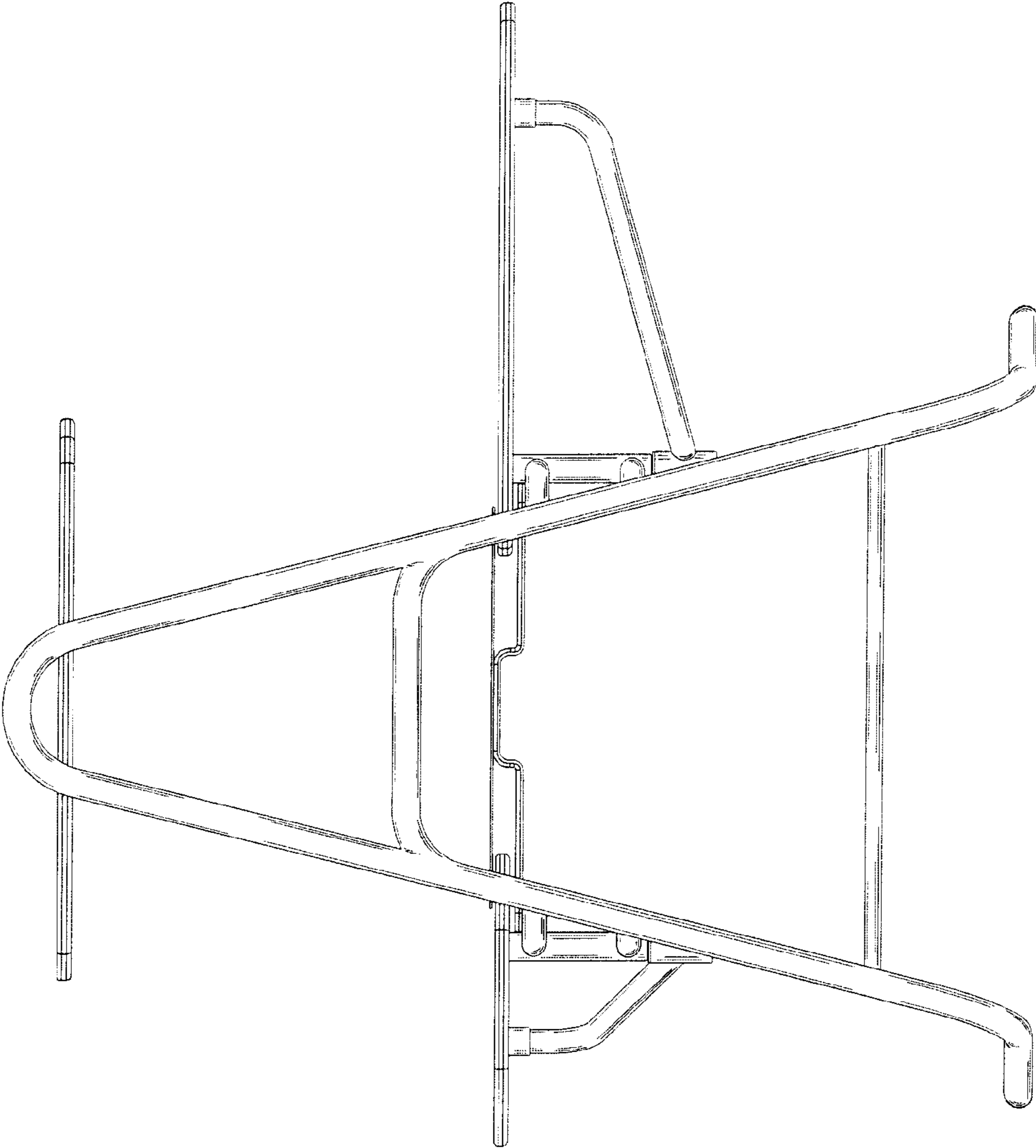

Fig. 10

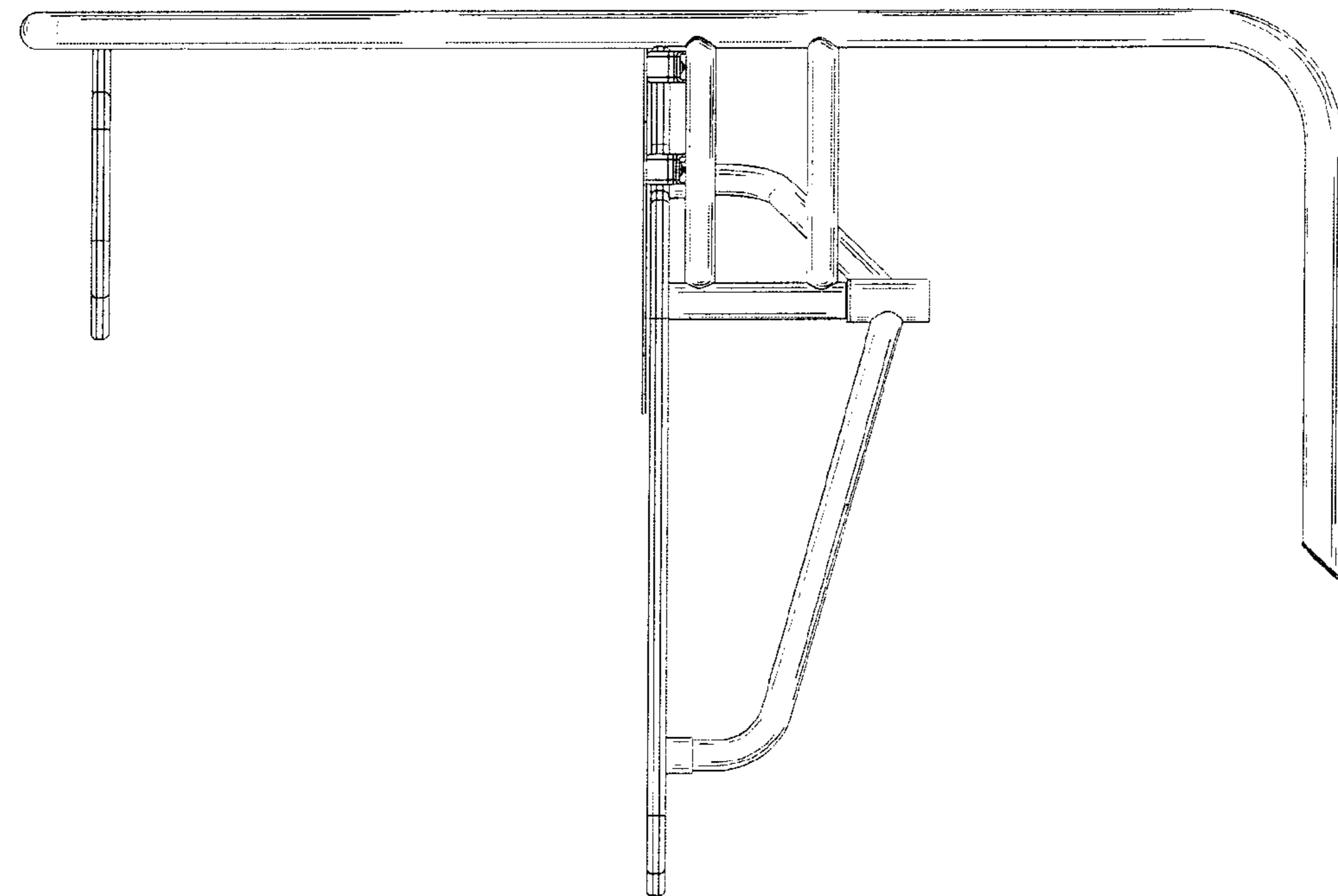

Fig. 12

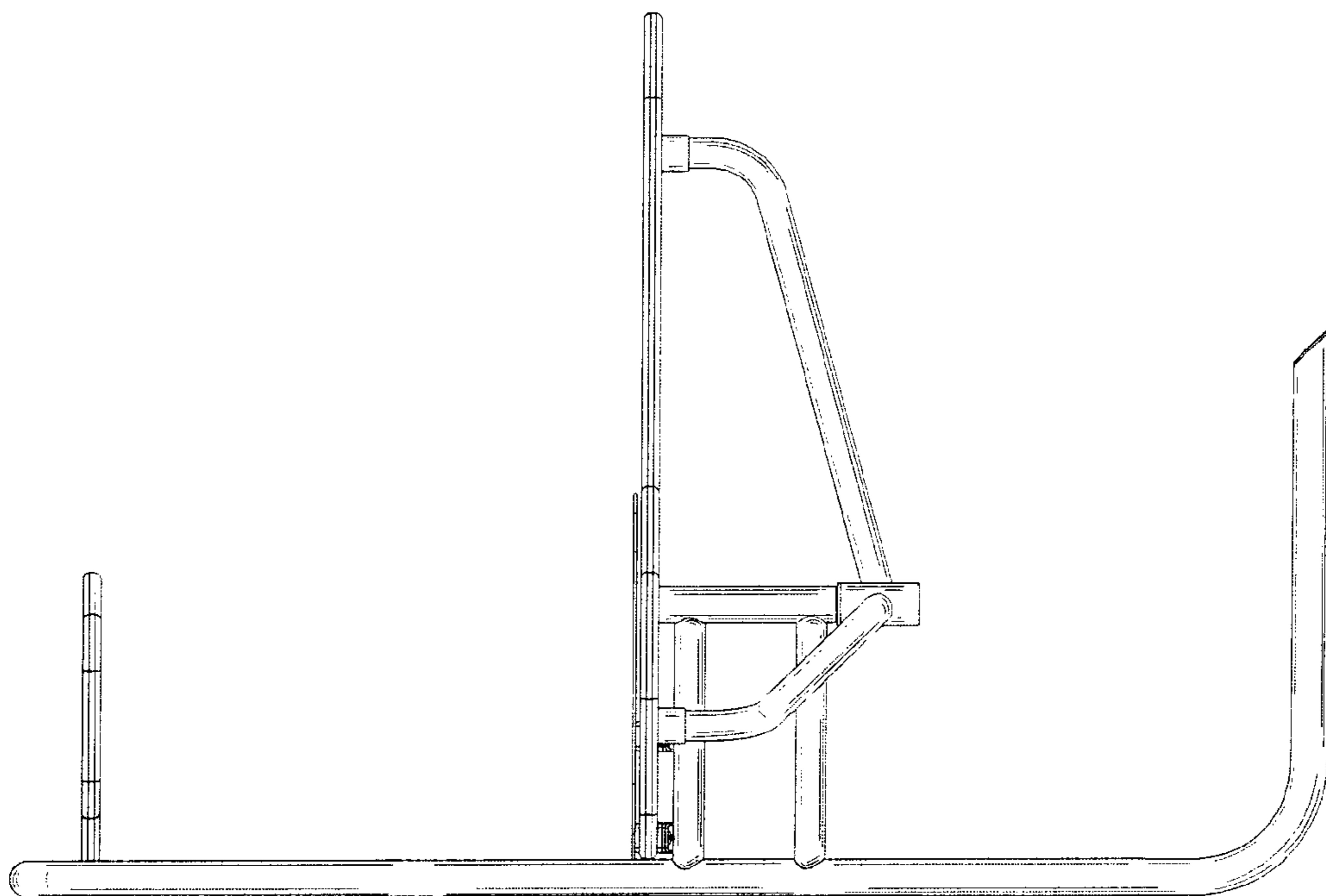

Fig. 11

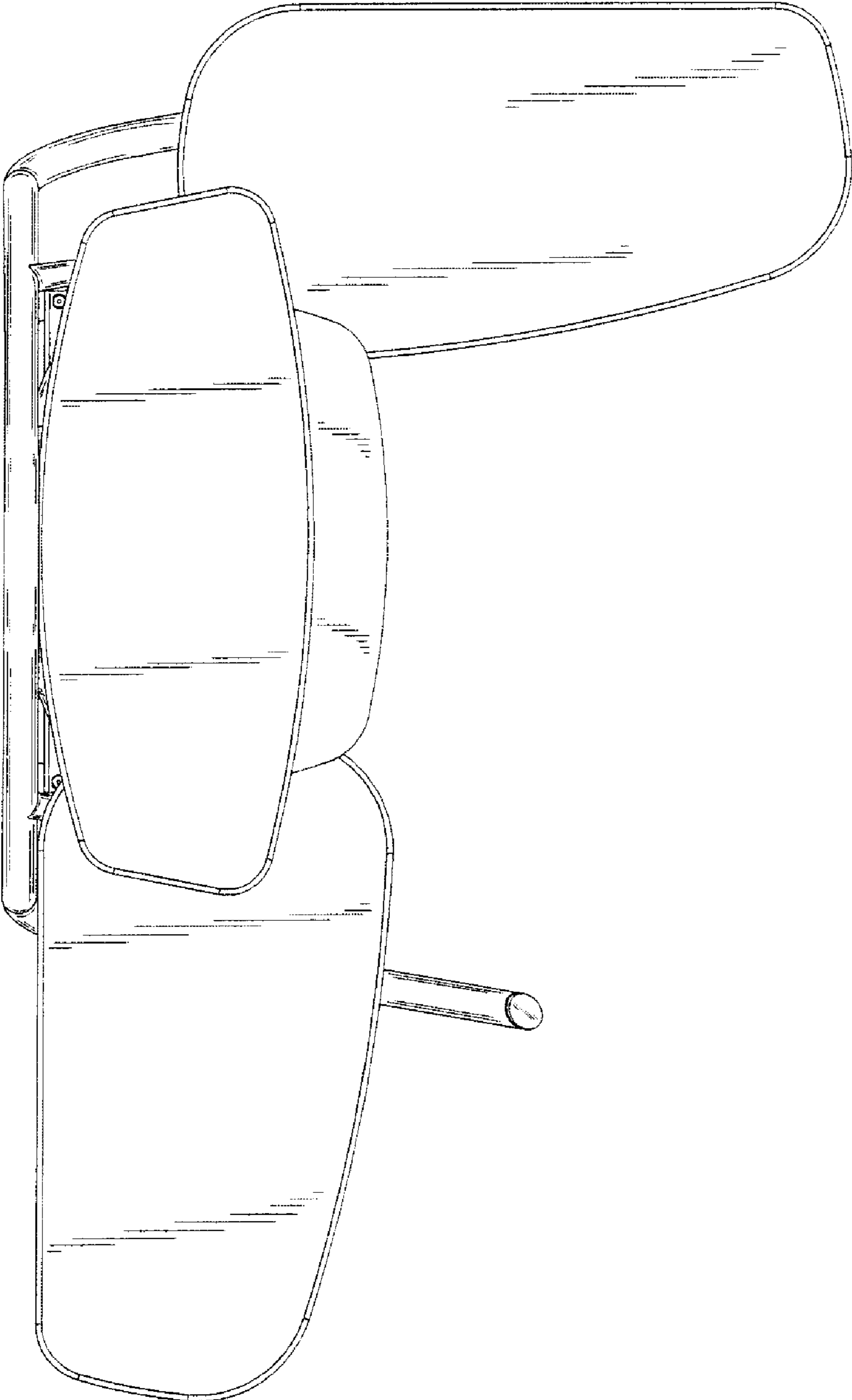

Fig. 13

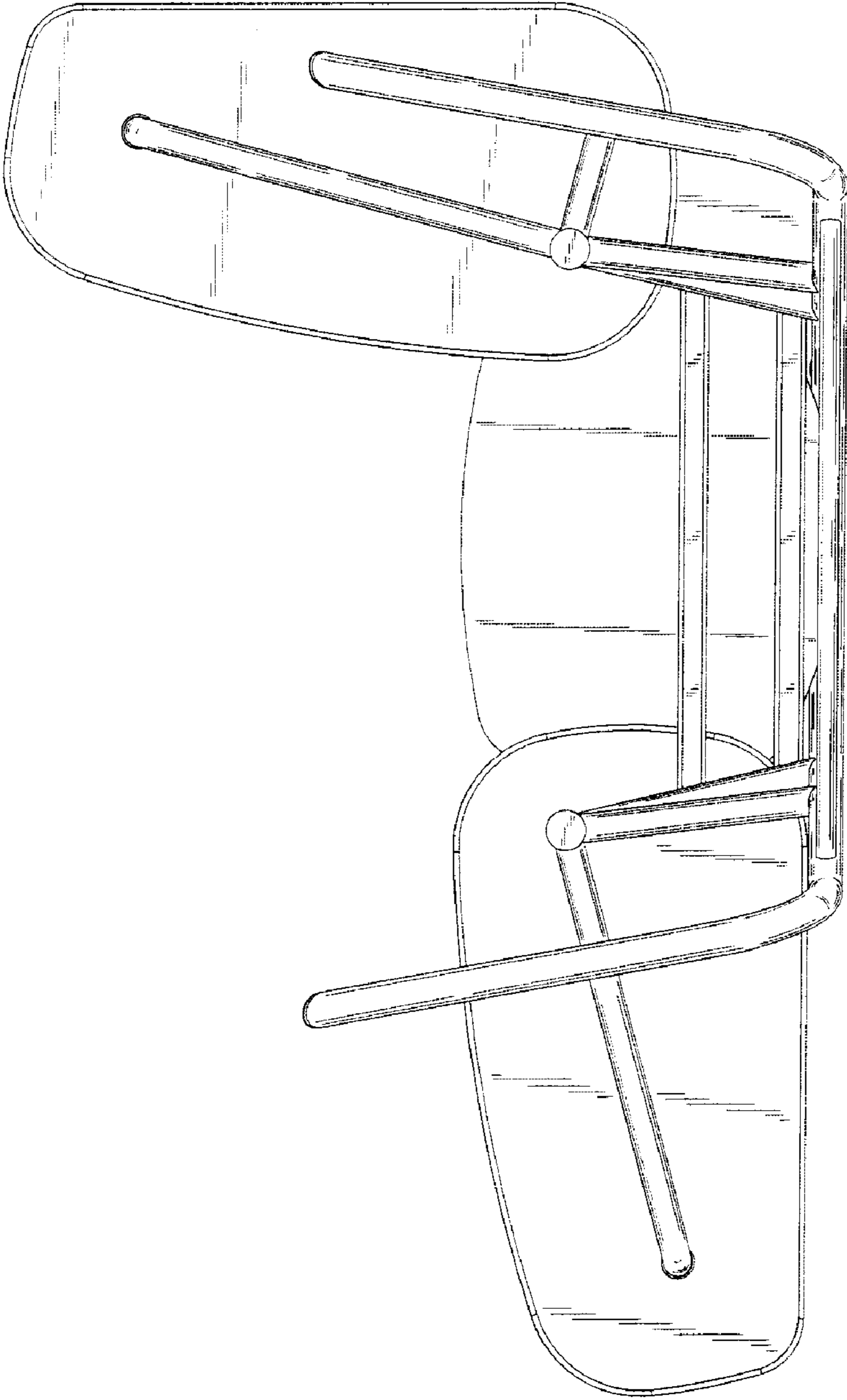

Fig. 14

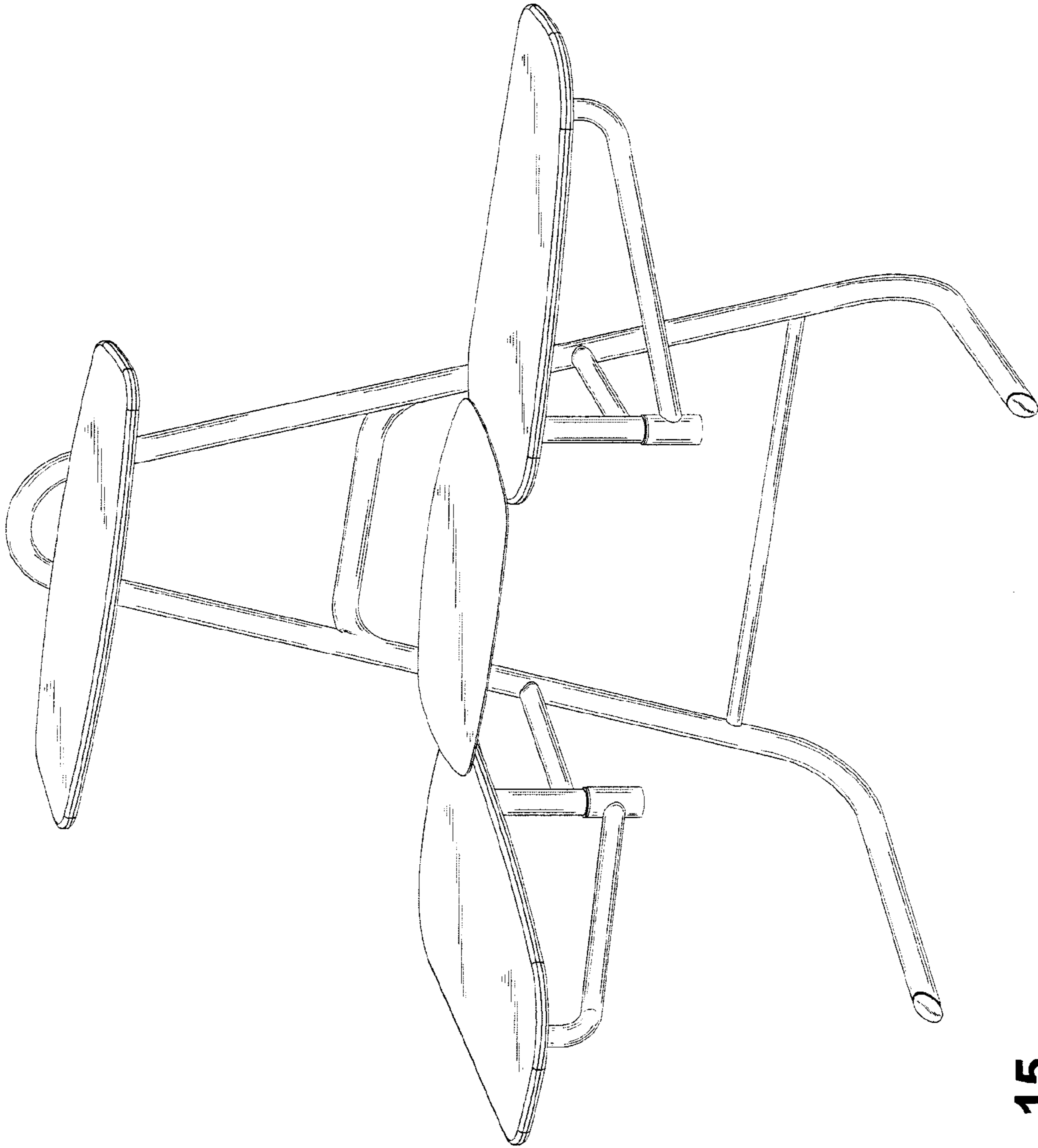

Fig. 15

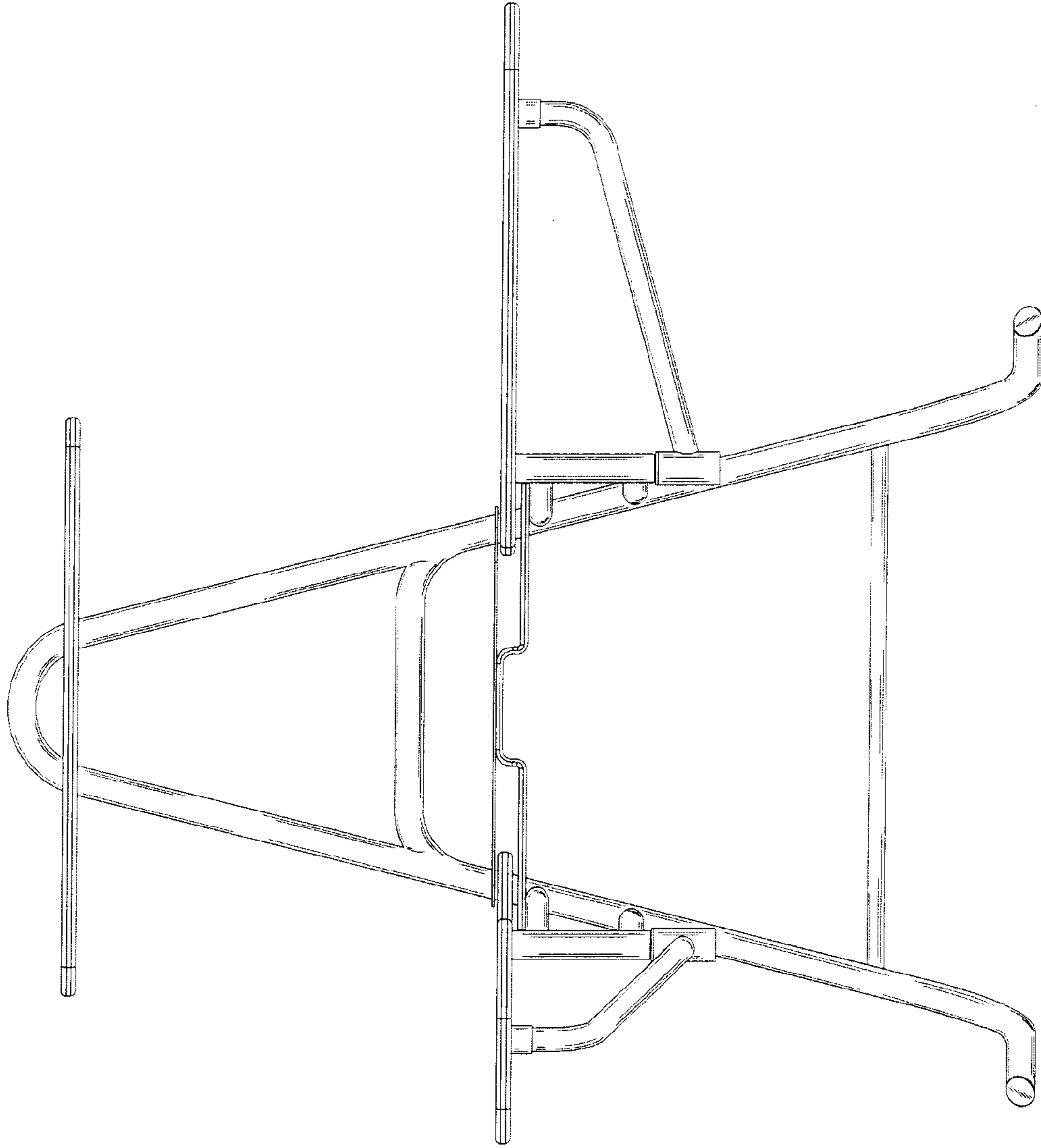

Fig. 16

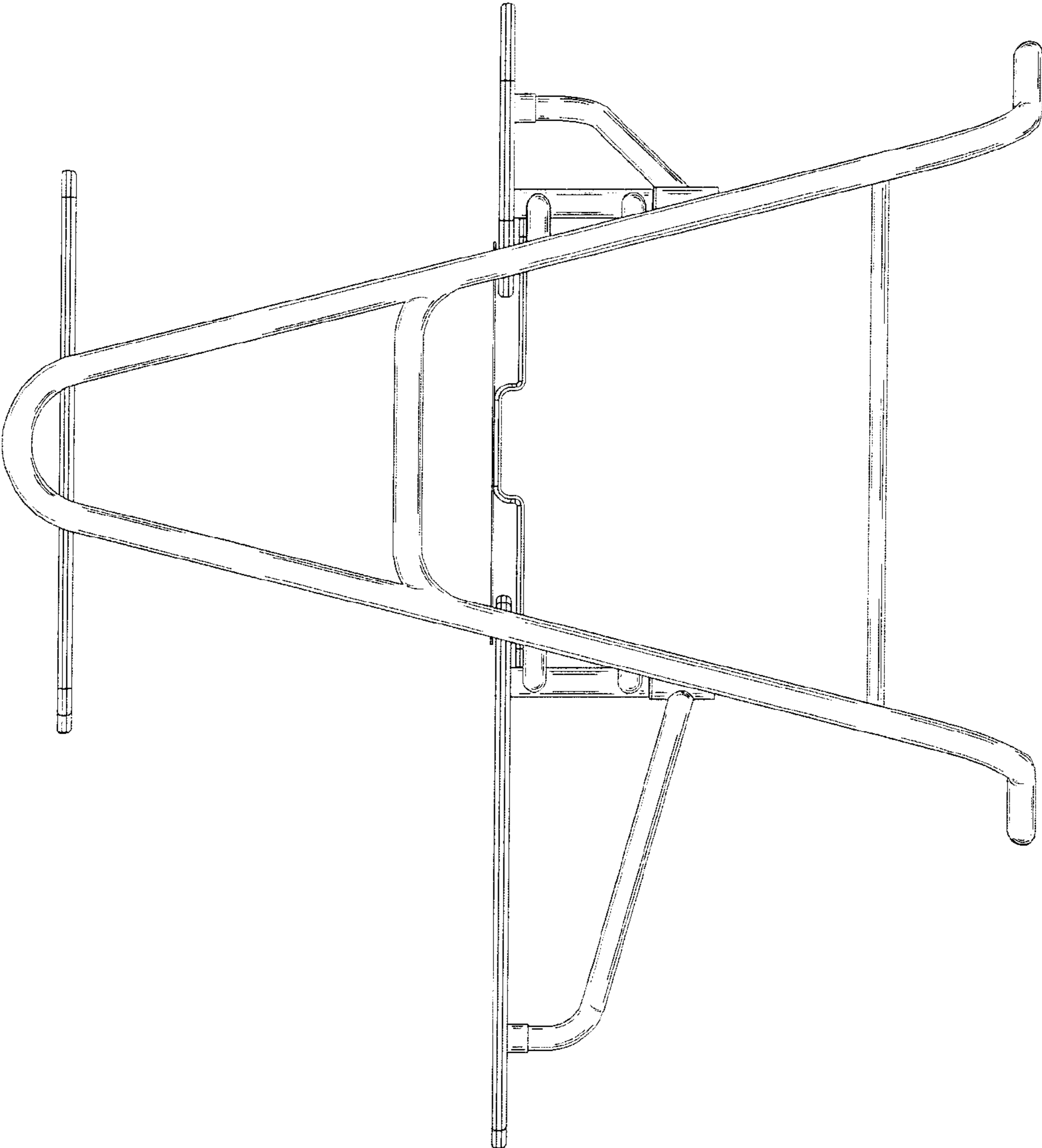

Fig. 17

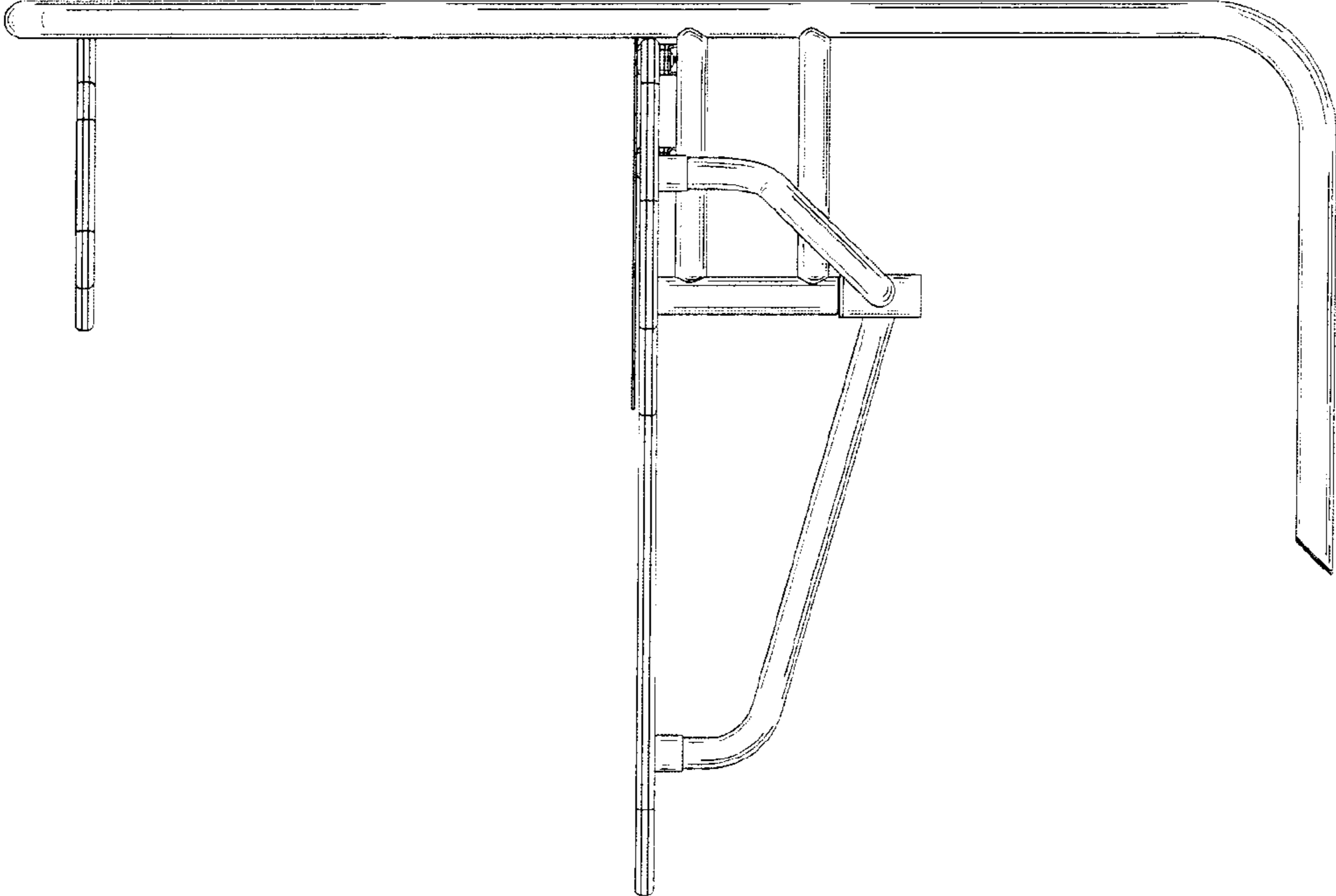

Fig. 19

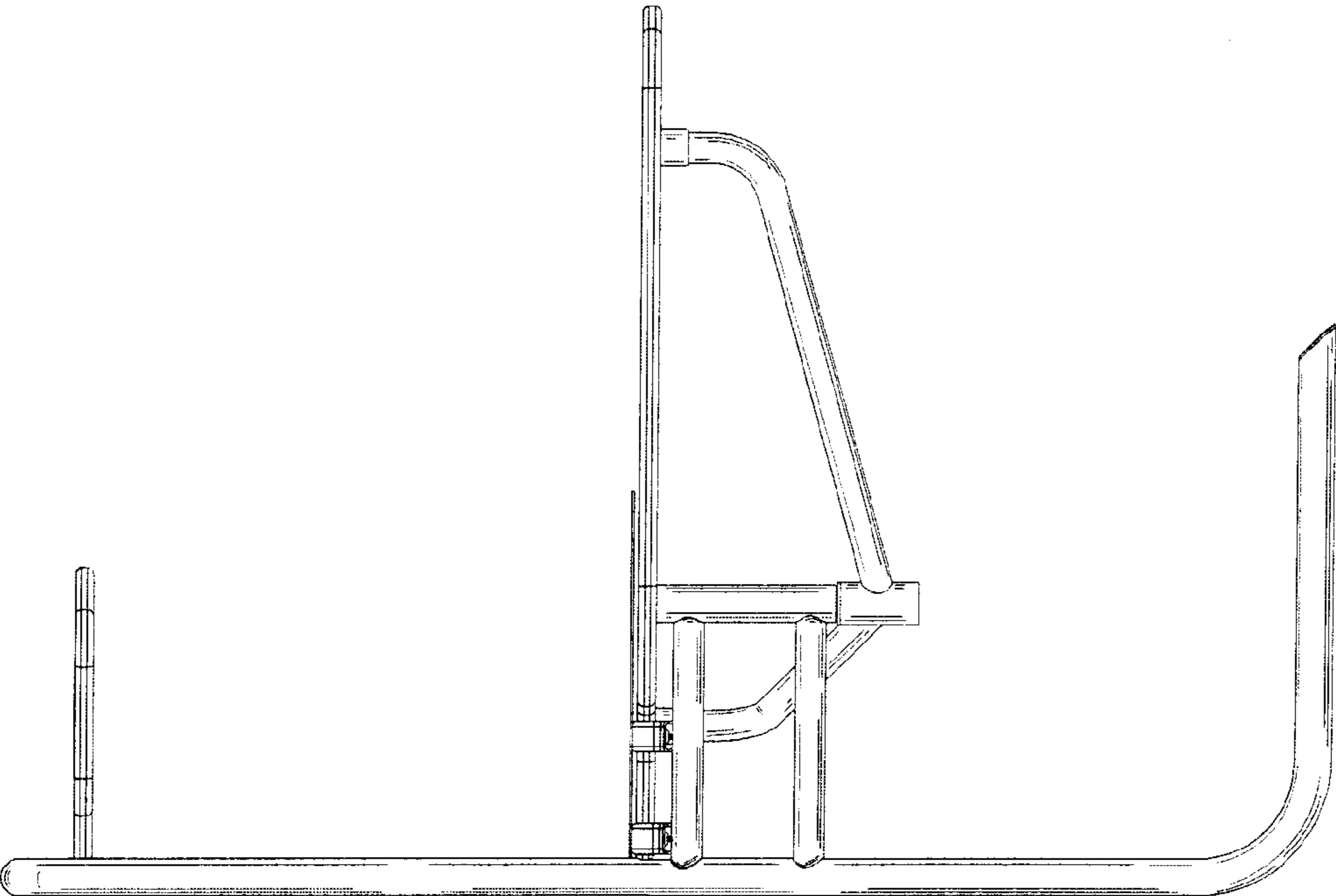

Fig. 18

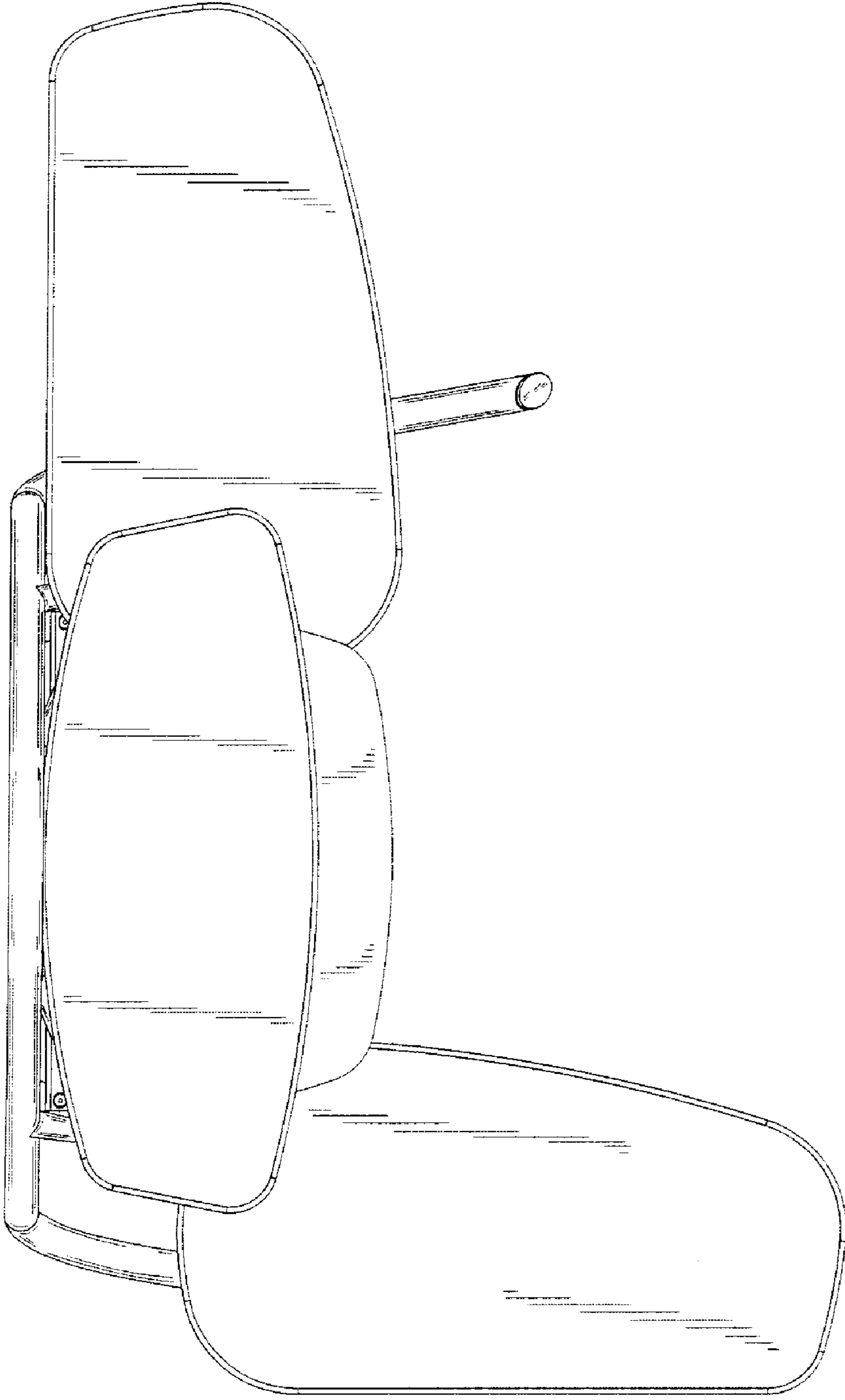

Fig. 20

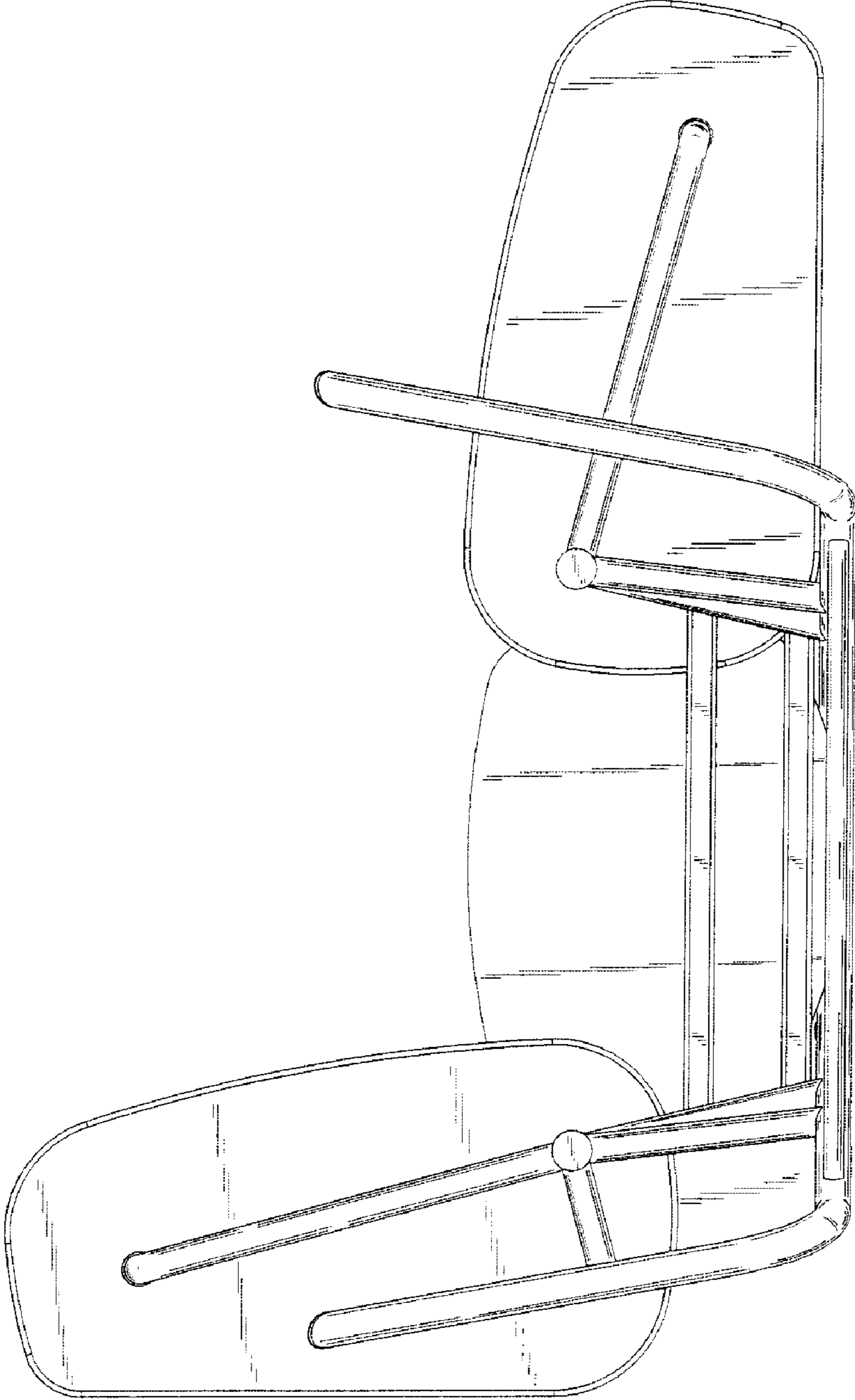

Fig. 21