



US00D583949S

(12) **United States Design Patent**
Hachimaru et al.

(10) **Patent No.:** **US D583,949 S**
(45) **Date of Patent:** **** Dec. 30, 2008**

(54) **SPHYGMOMANOMETER**

D551,348 S * 9/2007 Lee D24/165

(75) Inventors: **Izumi Hachimaru**, Kyoto (JP); **Tadashi Koike**, Kyoto (JP); **Yukiko Mitsunami**, Otsu (JP); **Yosuke Fujii**, Takatsuki (JP); **So Noguchi**, Hirakata (JP); **Shuji Tsuruta**, Ibaraki (JP); **Dong-Mei Wang**, Dalian Liaoning (CN); **Zhen-Hong Qu**, Dalian Liaoning (CN); **Hua-Li Zhao**, Dalian Liaoning (CN); **Gang Yin**, Dalian Liaoning (CN); **Kai Zhong**, Dalian Liaoning (CN)

FOREIGN PATENT DOCUMENTS

EP D000455654-0001 12/2005

OTHER PUBLICATIONS

Russian Office Action dated Apr. 1, 2008 in corresponding Russian Patent Application No. 2007501363, with English translation.

* cited by examiner

Primary Examiner—Louis S Zarfaz

Assistant Examiner—Anhdao Doan

(74) *Attorney, Agent, or Firm*—Harness, Dickey & Pierce PLC

(73) Assignee: **Omron Healthcare Co., Ltd.**, Kyoto (JP)

(**) Term: **14 Years**

(21) Appl. No.: **29/279,395**

(22) Filed: **Apr. 30, 2007**

(30) **Foreign Application Priority Data**

Oct. 31, 2006 (JP) 2006-029759

(51) **LOC (8) Cl.** **24-02**

(52) **U.S. Cl.** **D24/165**

(58) **Field of Classification Search** D24/165–169, D24/186; D10/98; 600/479–480, 485, 490, 600/493–495, 499, 500

See application file for complete search history.

(56) **References Cited**

U.S. PATENT DOCUMENTS

D341,659 S * 11/1993 Homayoun et al. D24/167

D345,607 S * 3/1994 Sodeoka et al. D24/165

D356,151 S * 3/1995 Ishii et al. D24/165

D537,944 S * 3/2007 Eda et al. D24/165

(57) **CLAIM**

The ornamental design for a sphygmomanometer, as shown and described.

DESCRIPTION

FIG. 1 is a perspective view of a sphygmomanometer showing our new design;

FIG. 2 is a front elevational view thereof;

FIG. 3 is a rear elevational view thereof;

FIG. 4 is a top plan view thereof;

FIG. 5 is a bottom plan view thereof; and,

FIG. 6 is a right side elevational view thereof, the left side being a mirror image thereof.

The alternating dot and dash lines immediately adjacent the shaded areas represent the bounds of the claim, and the evenly spaced broken lines are included for the purpose of illustrating portions of the sphygmomanometer that form no part of the claimed design. None of the broken lines form a part of the claimed design.

1 Claim, 5 Drawing Sheets

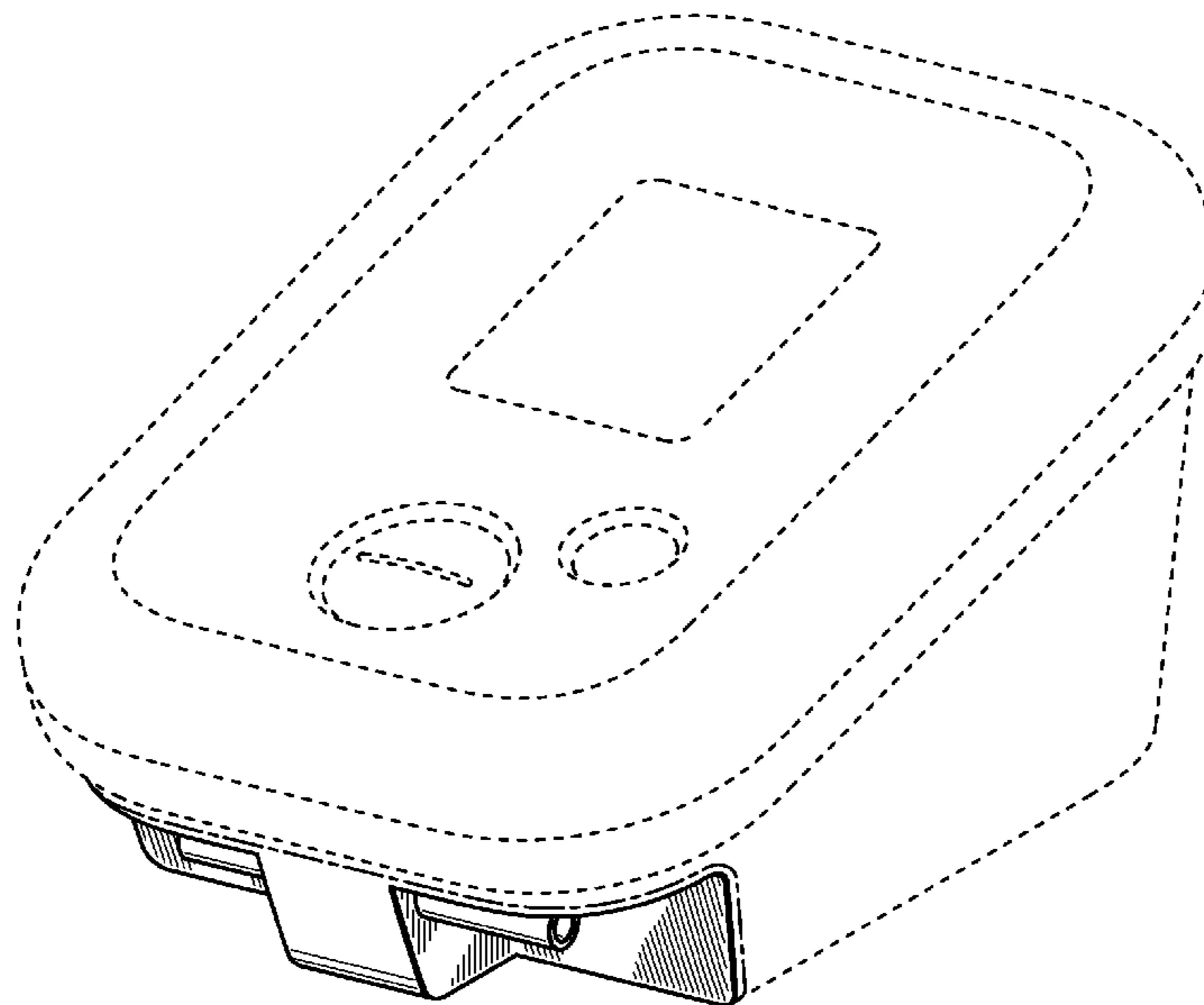

Fig. 1

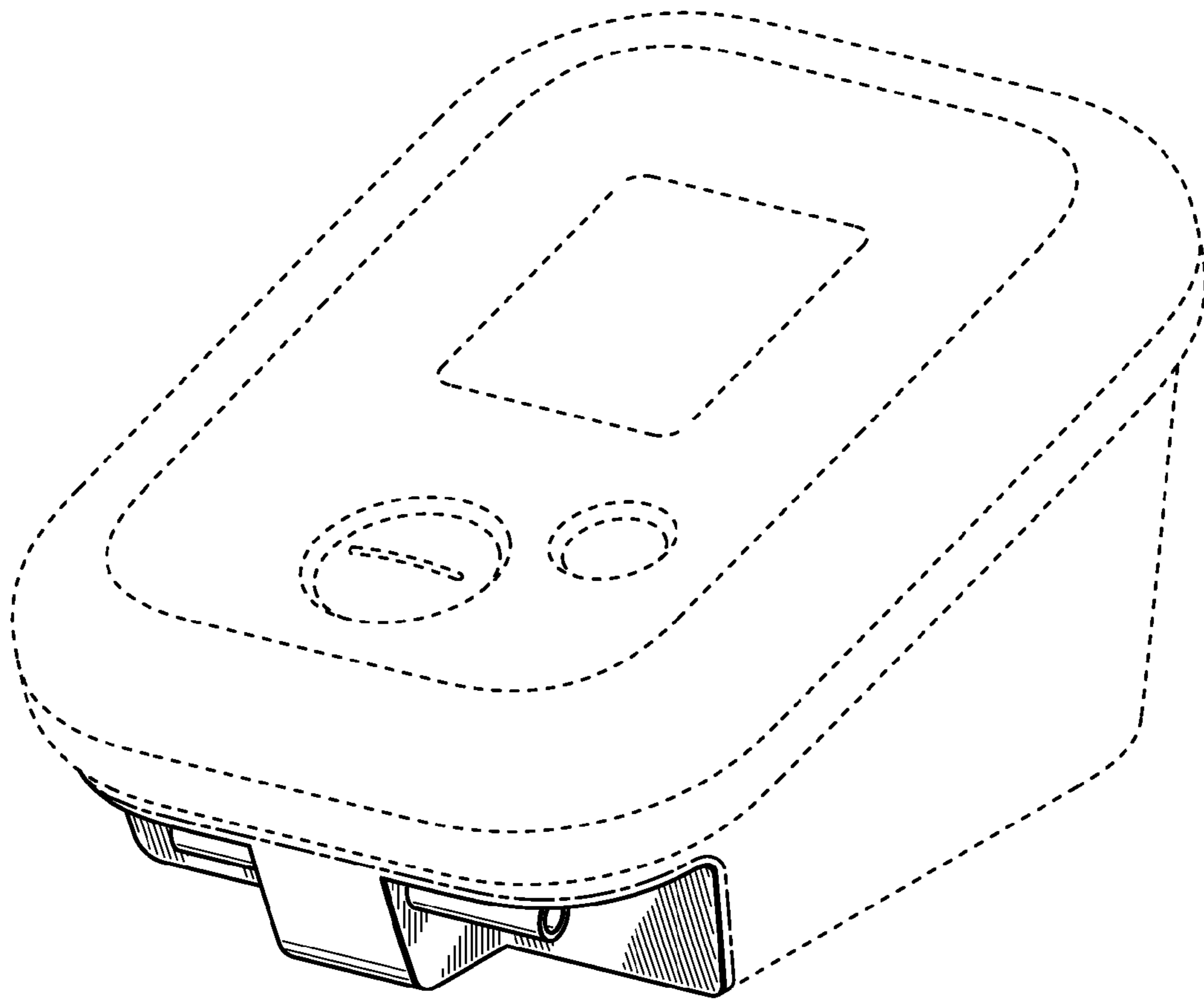

Fig. 2

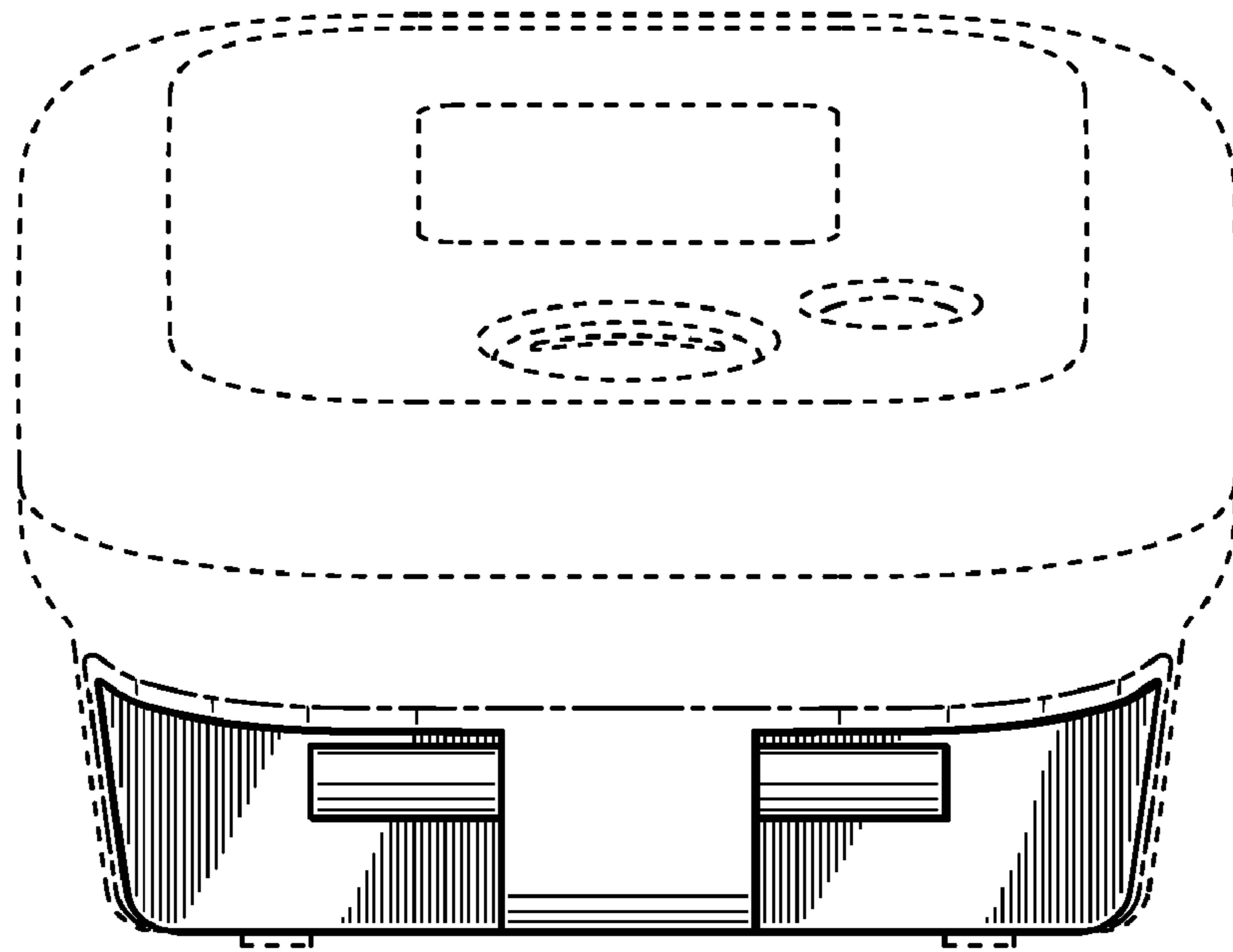

Fig. 3

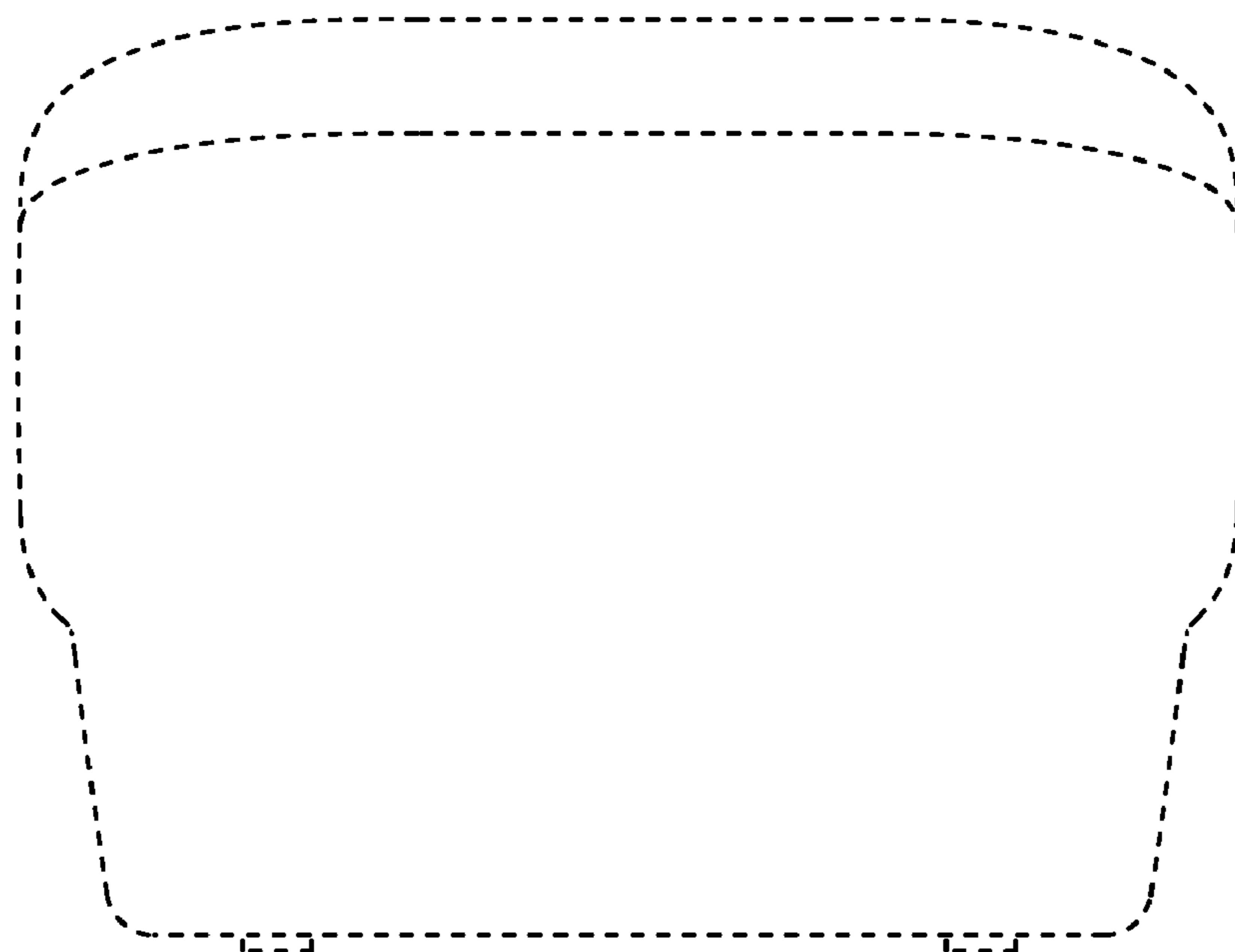

Fig. 4

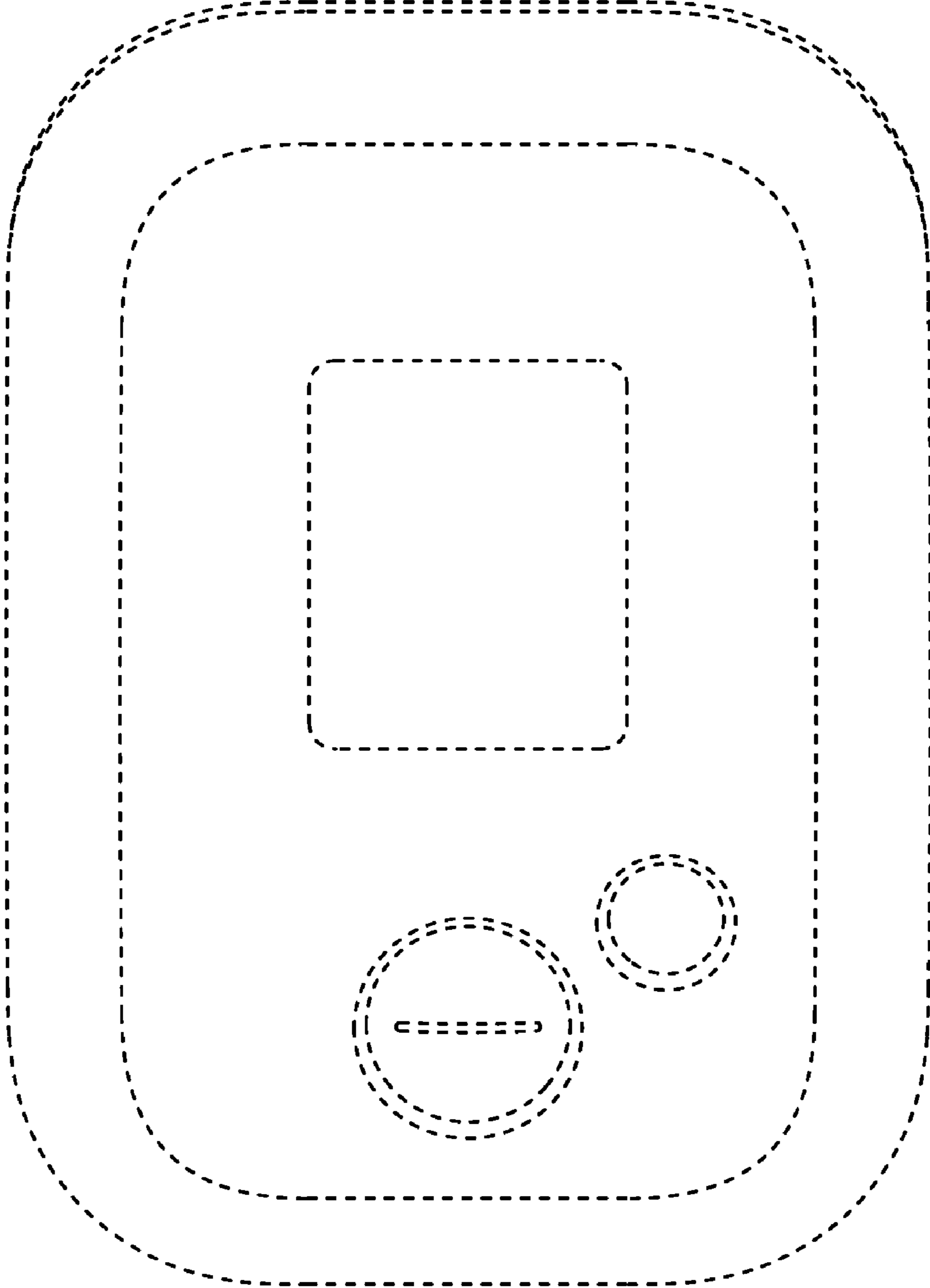

Fig. 5

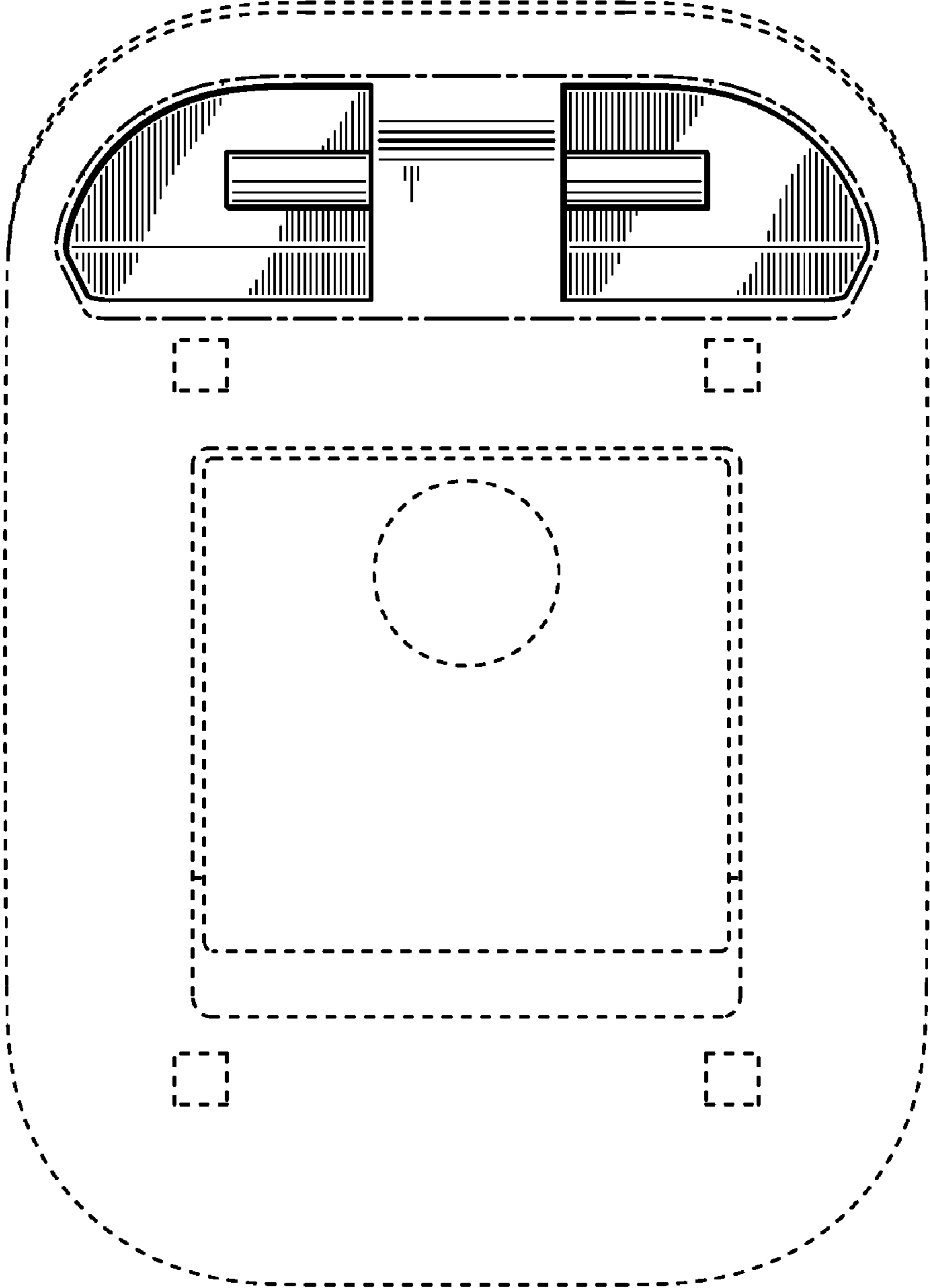

Fig. 6

