



US00D583330S

(12) **United States Design Patent**
Nakamura

(10) **Patent No.:** **US D583,330 S**

(45) **Date of Patent:** **** Dec. 23, 2008**

(54) **ELECTRICAL CONNECTOR**

(75) Inventor: **Keisuke Nakamura**, Tokyo (JP)

(73) Assignee: **Japan Aviation Electronics Industry, Limited**, Tokyo (JP)

(**) Term: **14 Years**

(21) Appl. No.: **29/301,293**

(22) Filed: **Feb. 21, 2008**

(30) **Foreign Application Priority Data**

Nov. 15, 2007 (JP) 2007-031553

(51) **LOC (8) Cl.** **13-03**

(52) **U.S. Cl.** **D13/147**

(58) **Field of Classification Search** D13/146-147,
D13/154, 184; 439/79, 159-160, 260, 325,
439/395, 607-610, 630

See application file for complete search history.

(56) **References Cited**

U.S. PATENT DOCUMENTS

5,288,247 A * 2/1994 Kaufman 439/607
D425,485 S * 5/2000 Nishio et al. D13/147
D434,731 S * 12/2000 Wu D13/147
D497,597 S * 10/2004 Kimura et al. D13/147
D517,492 S * 3/2006 Nakamura et al. D13/147

D537,042 S * 2/2007 Sasaki D13/147
2004/0127098 A1 * 7/2004 Kuo et al. 439/607

* cited by examiner

Primary Examiner—Daniel D Bui

(74) *Attorney, Agent, or Firm*—Collard & Roe, P.C.

(57) **CLAIM**

The ornamental design for an electrical connector, as shown and described.

DESCRIPTION

FIG. 1 is a front, right, and top-side perspective view of an electrical connector showing my new design;

FIG. 2 is a rear, right, and bottom-side perspective view thereof;

FIG. 3 is a front elevational view thereof;

FIG. 4 is a top plan view thereof;

FIG. 5 is a rear elevational view thereof;

FIG. 6 is a bottom plan view thereof; and,

FIG. 7 is a right side elevational view thereof, the right side elevational view thereof is a mirror image thereto.

The broken line of the internal elements in FIG. 3 is included to show unclaimed subject matter only and forms no part of the claimed design.

1 Claim, 5 Drawing Sheets

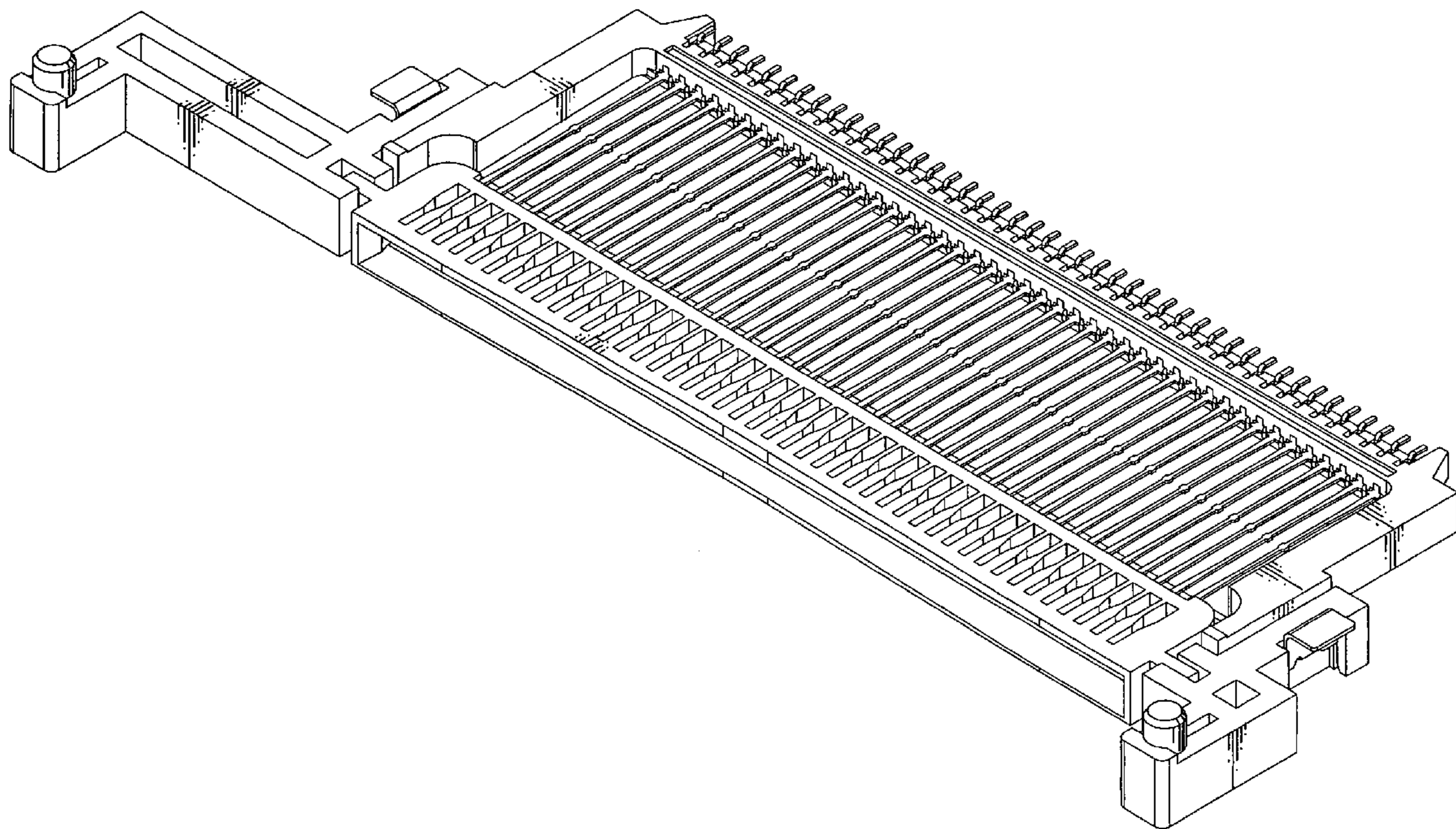

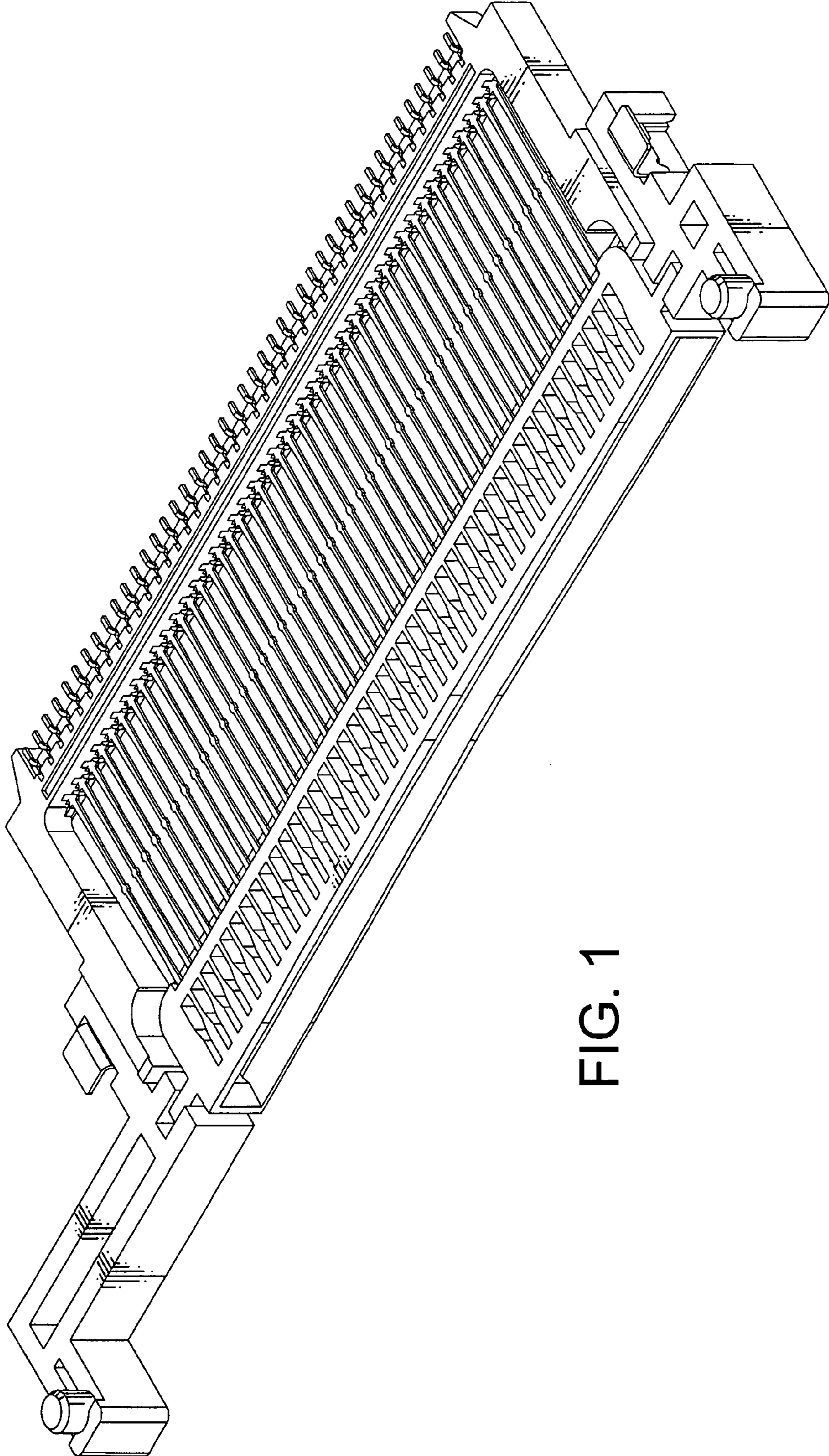

FIG. 1

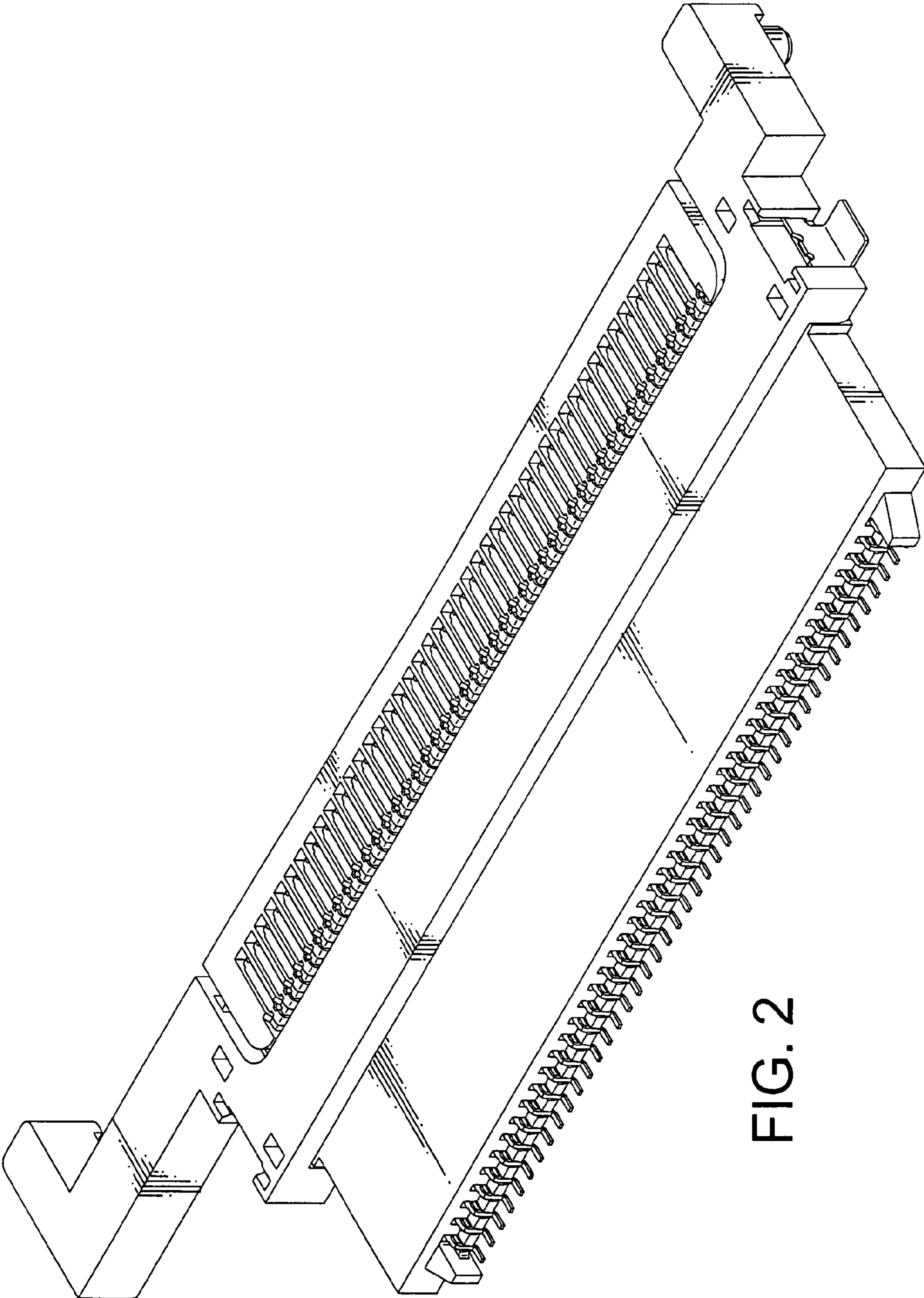

FIG. 2

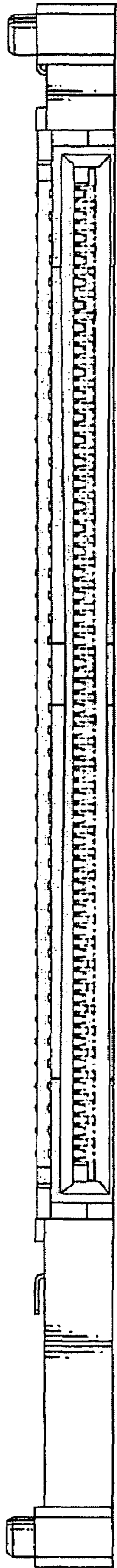

FIG. 3

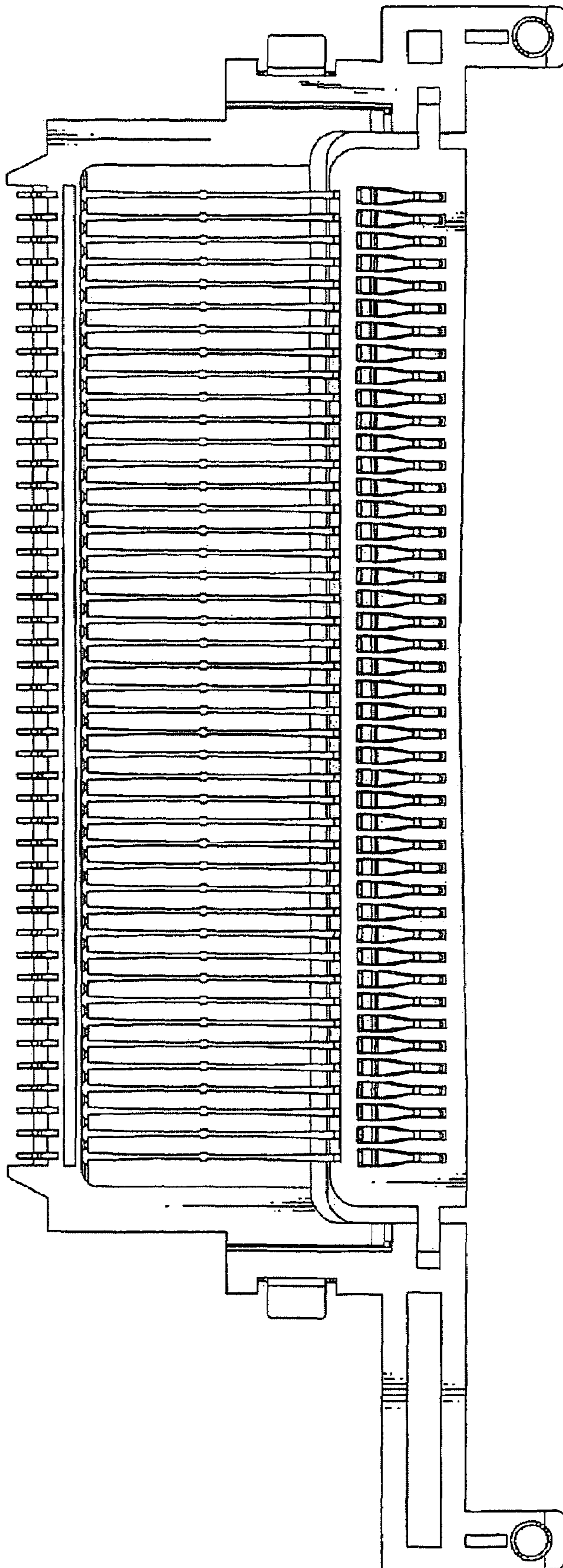

FIG. 4

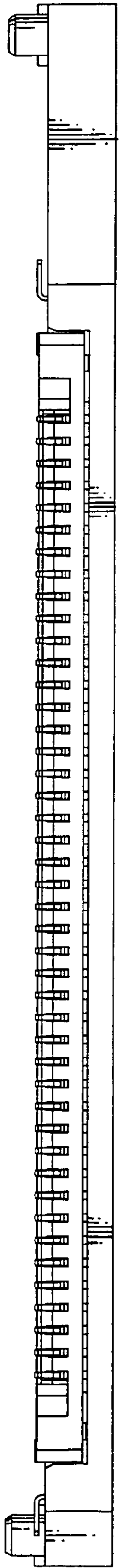

FIG. 5

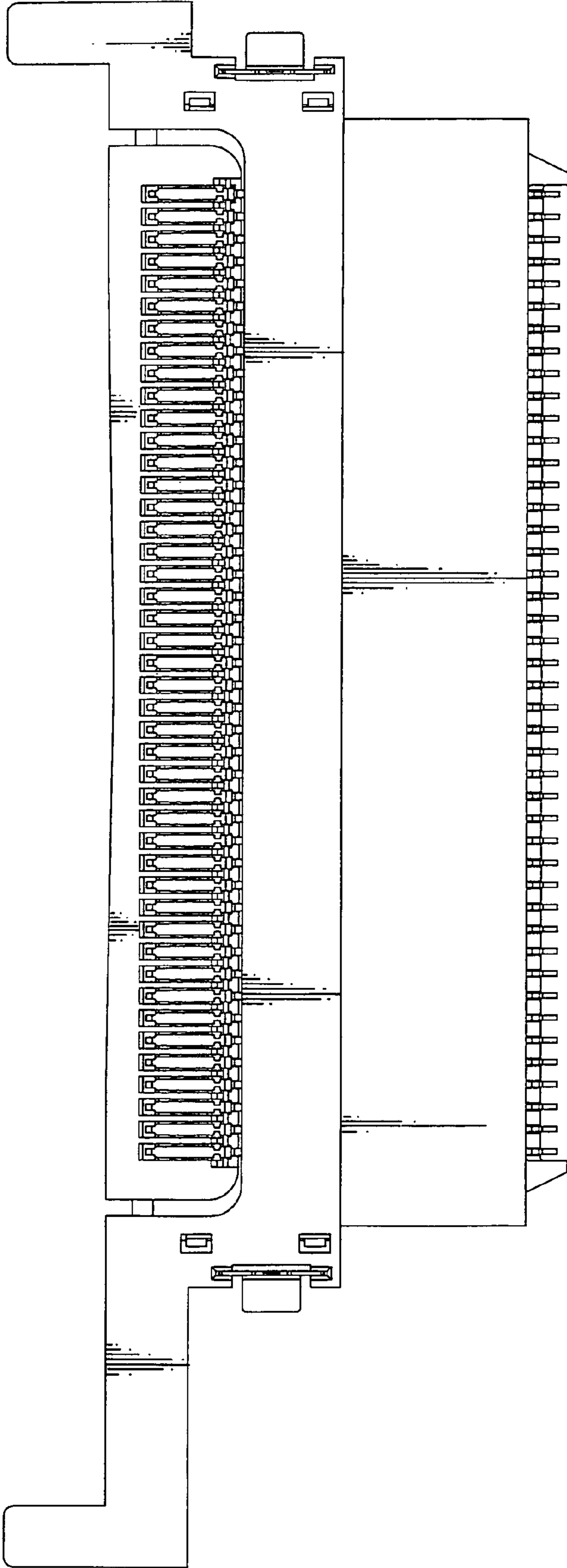

FIG. 6

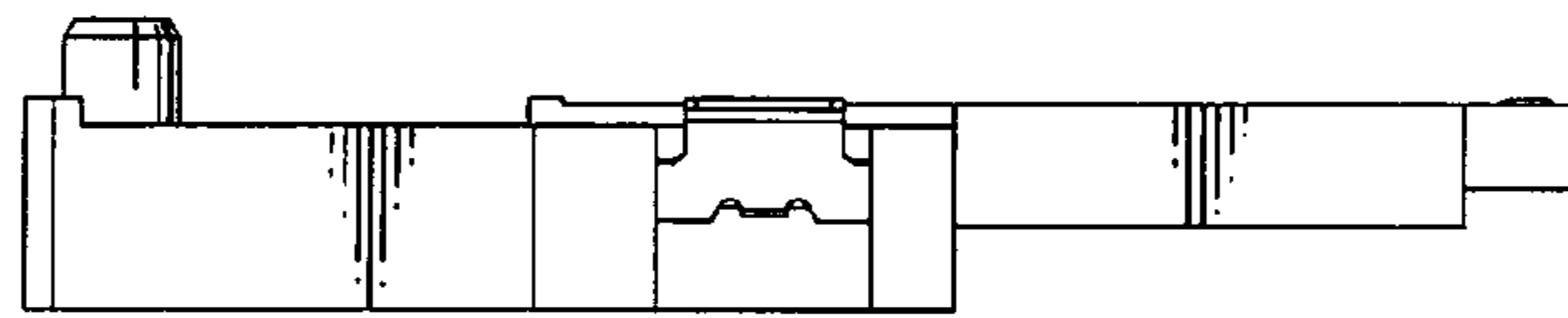

FIG. 7