



US00D583289S

(12) **United States Design Patent**
Leclercq

(10) **Patent No.:** **US D583,289 S**
(45) **Date of Patent:** **** Dec. 23, 2008**

(54) **DOOR FOR A VEHICLE**

(75) Inventor: **Pierre Leclercq**, Munich (DE)

(73) Assignee: **Bayerische Motoren Werke Aktiengesellschaft**, Munich (DE)

(**) Term: **14 Years**

(21) Appl. No.: **29/294,031**

(22) Filed: **Dec. 21, 2007**

(30) **Foreign Application Priority Data**

Jun. 27, 2007 (DE) 40703309

(51) **LOC (8) Cl.** **12-16**

(52) **U.S. Cl.** **D12/196**

(58) **Field of Classification Search** D12/196,
D12/90-92, 86; 296/181.1, 181.5

See application file for complete search history.

(56) **References Cited**

U.S. PATENT DOCUMENTS

D418,471 S *	1/2000	Gabath	D12/196
D467,849 S *	12/2002	Murkett	D12/196
D479,170 S *	9/2003	Boyer	D12/196
D491,860 S *	6/2004	Velazco	D12/196
D511,129 S	11/2005	Nagashima		
D558,112 S	12/2007	Leclercq		

* cited by examiner

Primary Examiner—Melody N Brown
(74) *Attorney, Agent, or Firm*—Crowell & Moring LLP

(57) **CLAIM**

The ornamental design for a door for a vehicle, as shown and described.

DESCRIPTION

This application is related to the following co-pending application: Application Ser. No. 29/294,059, entitled “Vehicle, Toy, or Likeness Thereof”.

FIG. 1 is a left perspective view of a first embodiment of a door for a vehicle according to my novel design;

FIG. 2 is a right perspective view thereof;

FIG. 3 is a front view thereof;

FIG. 4 is a top view thereof; and

FIG. 5 is a left side view thereof.

FIG. 6 is a right perspective view of a second embodiment of the door for a vehicle according to my novel design;

FIG. 7 is a left perspective view of FIG. 6;

FIG. 8 is a front view of FIG. 6;

FIG. 9 is a top view of FIG. 6; and,

FIG. 10 is a right side view of FIG. 6.

The broken lines are for illustrative purposes only and form no part of the claimed design.

1 Claim, 4 Drawing Sheets

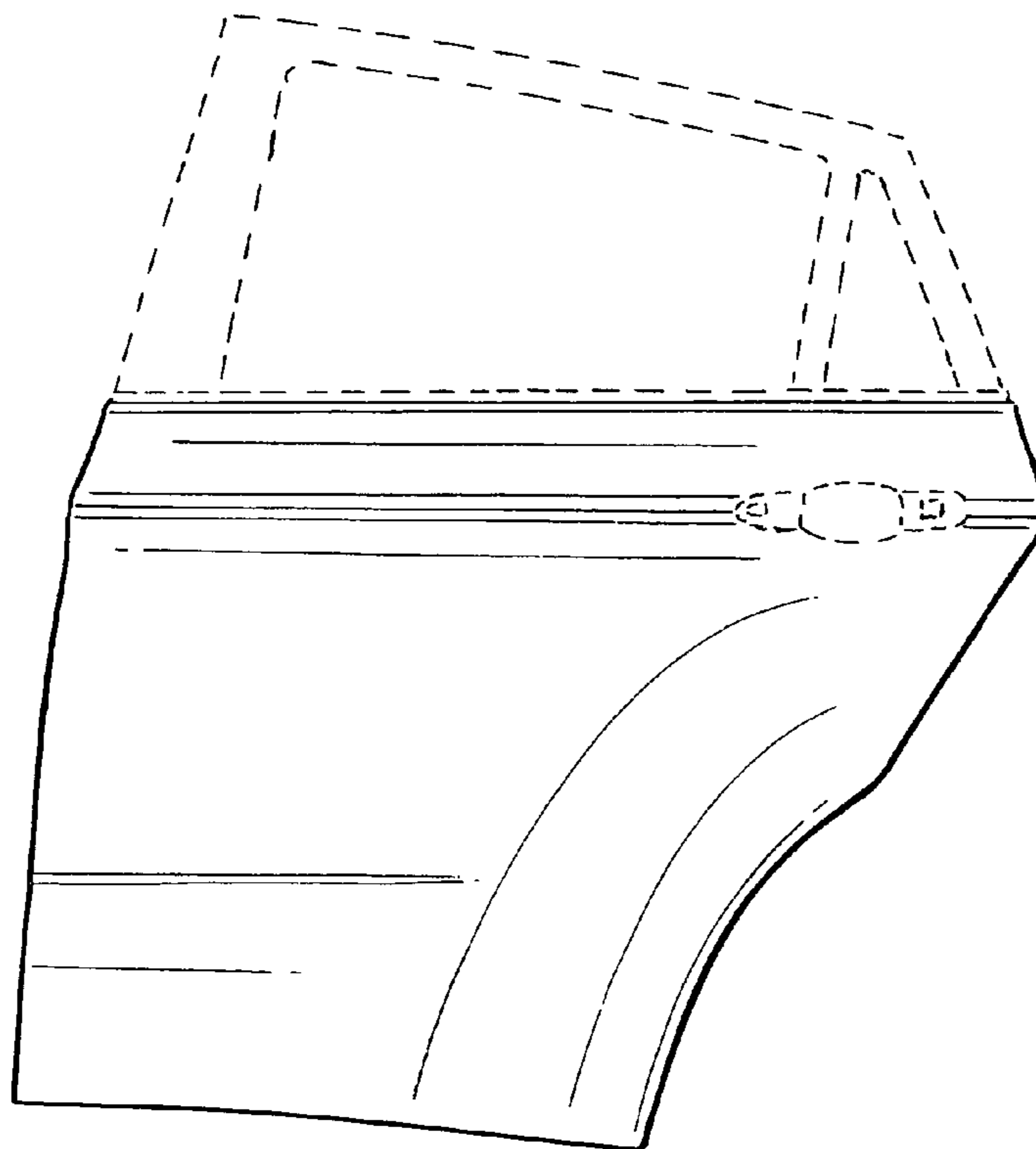

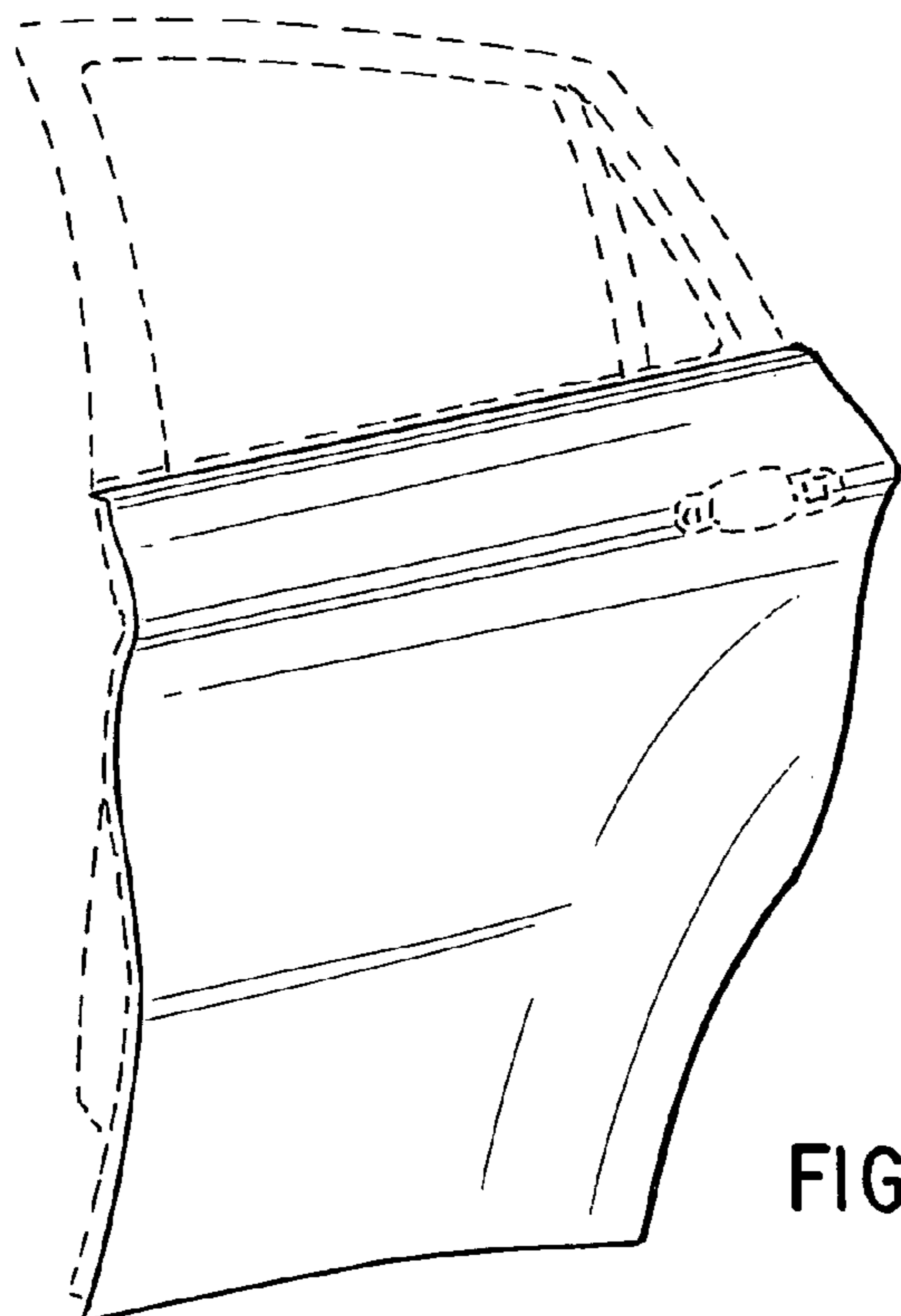

FIG. 1

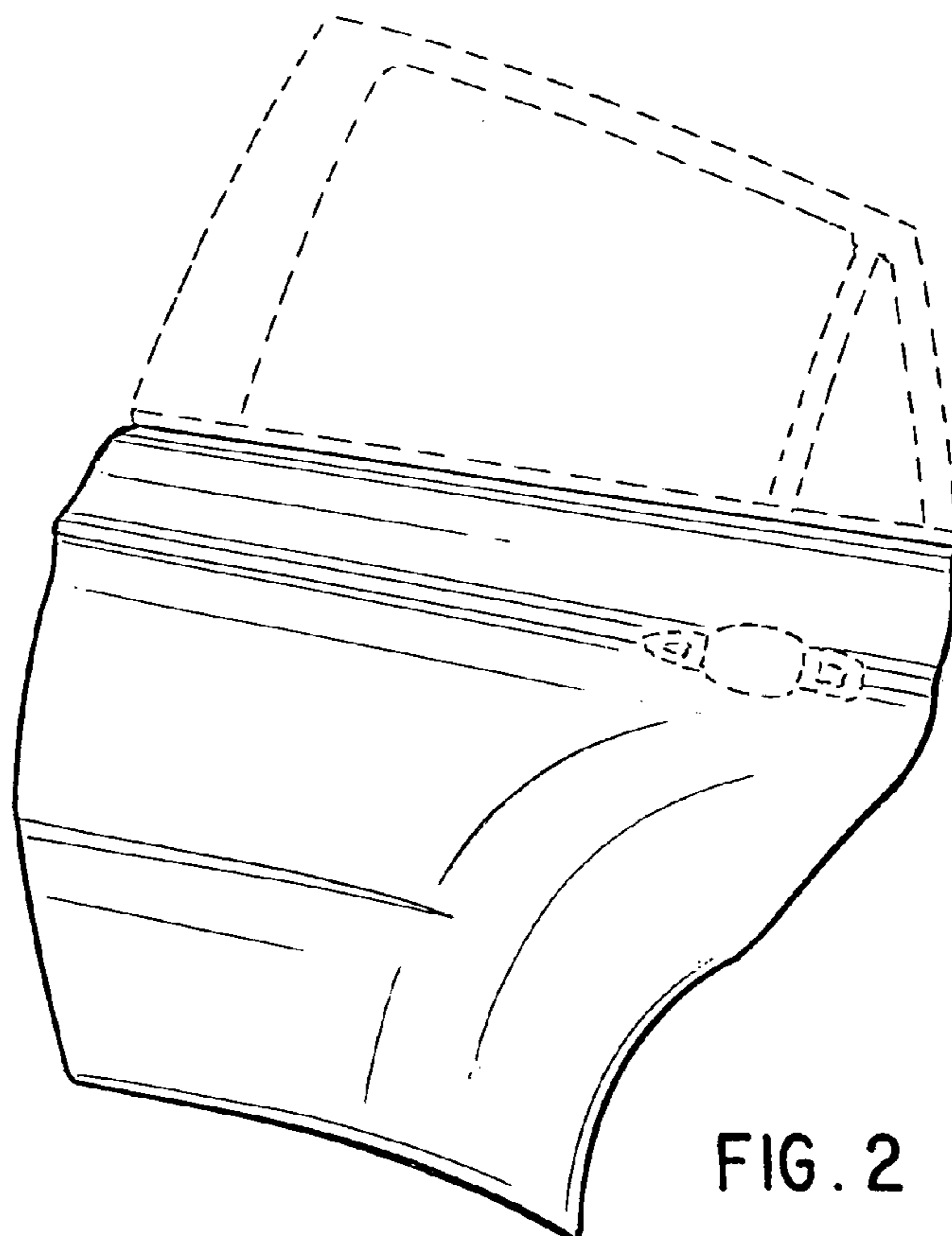

FIG. 2

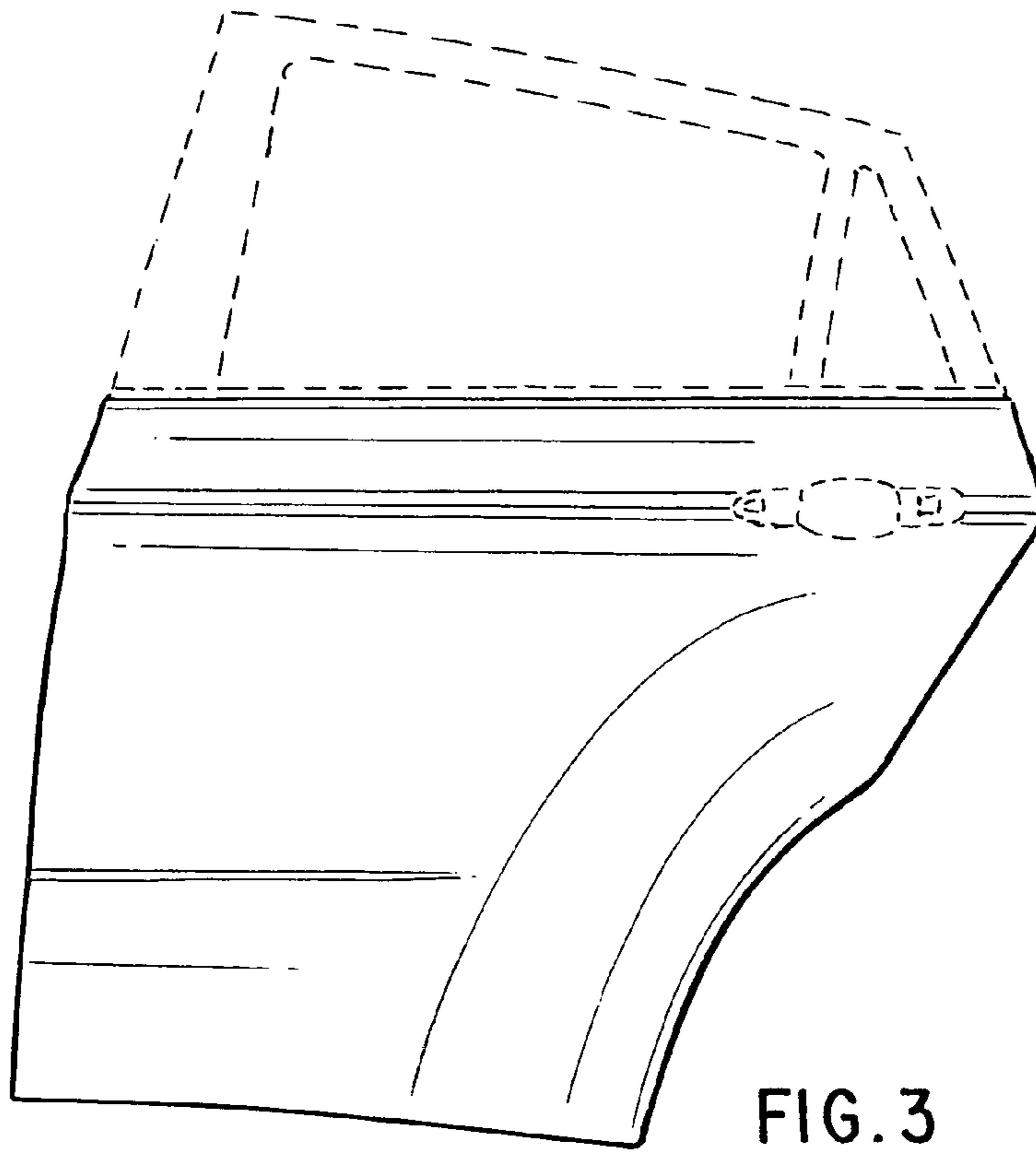

FIG. 3

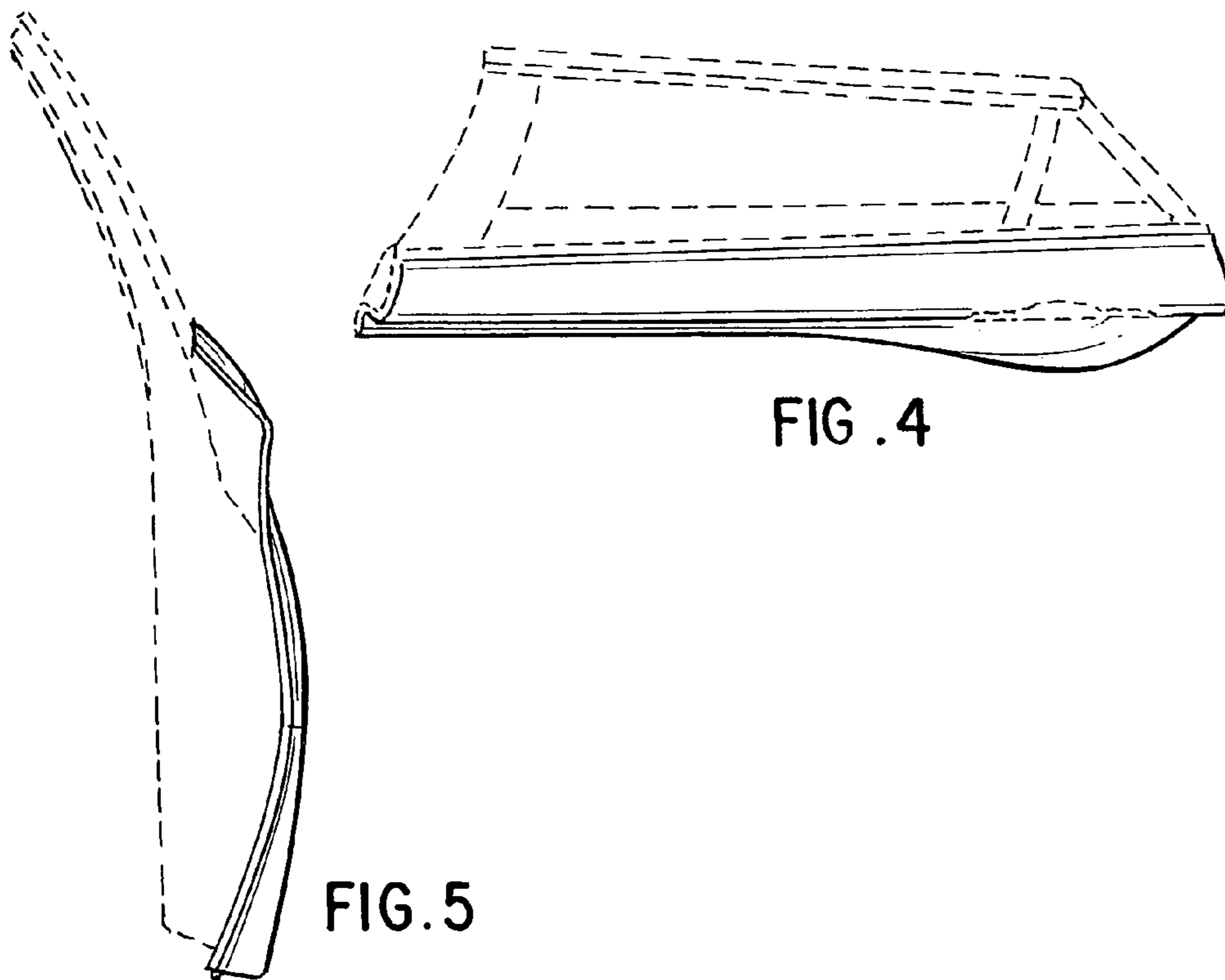

FIG. 4

FIG. 5

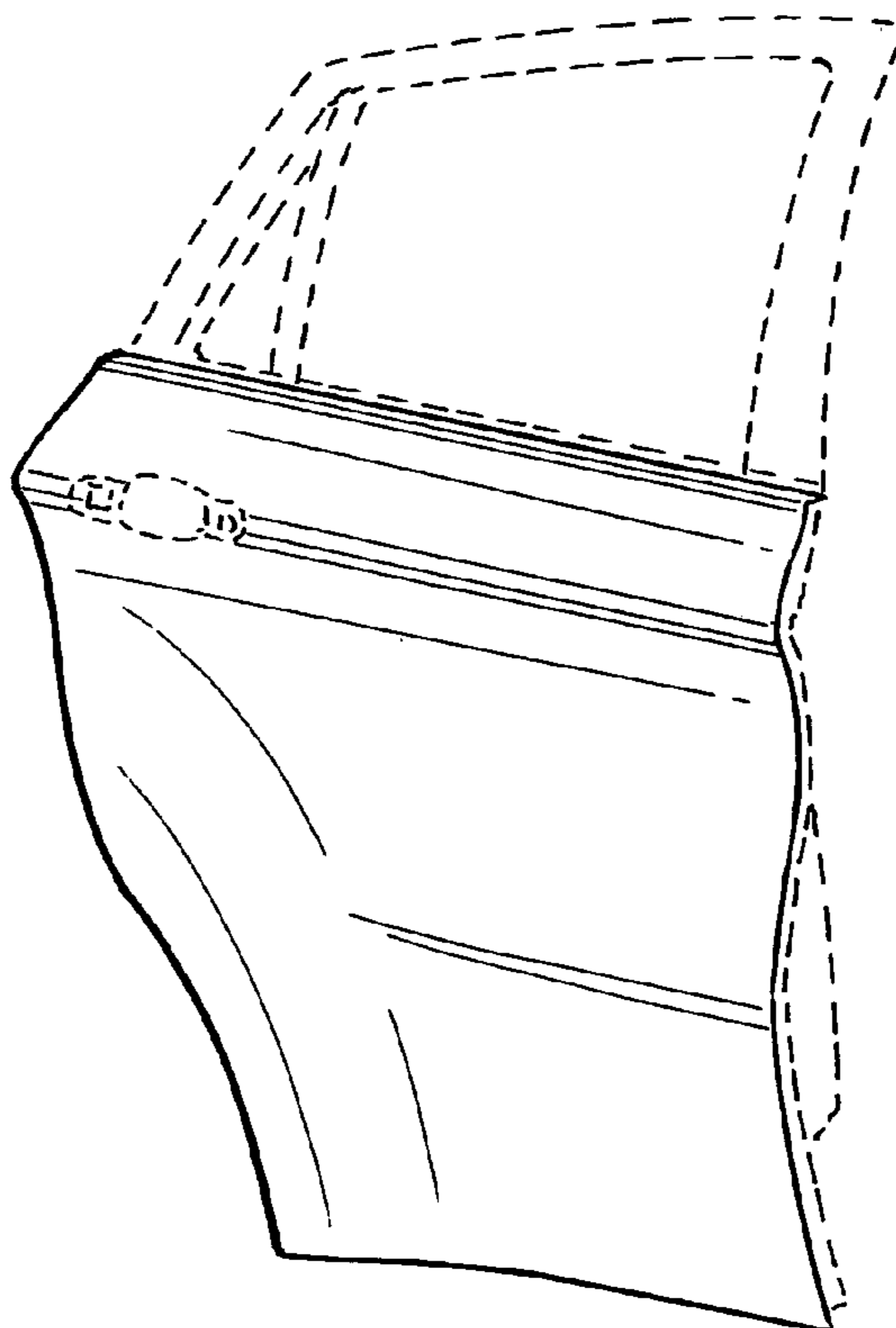

FIG. 6

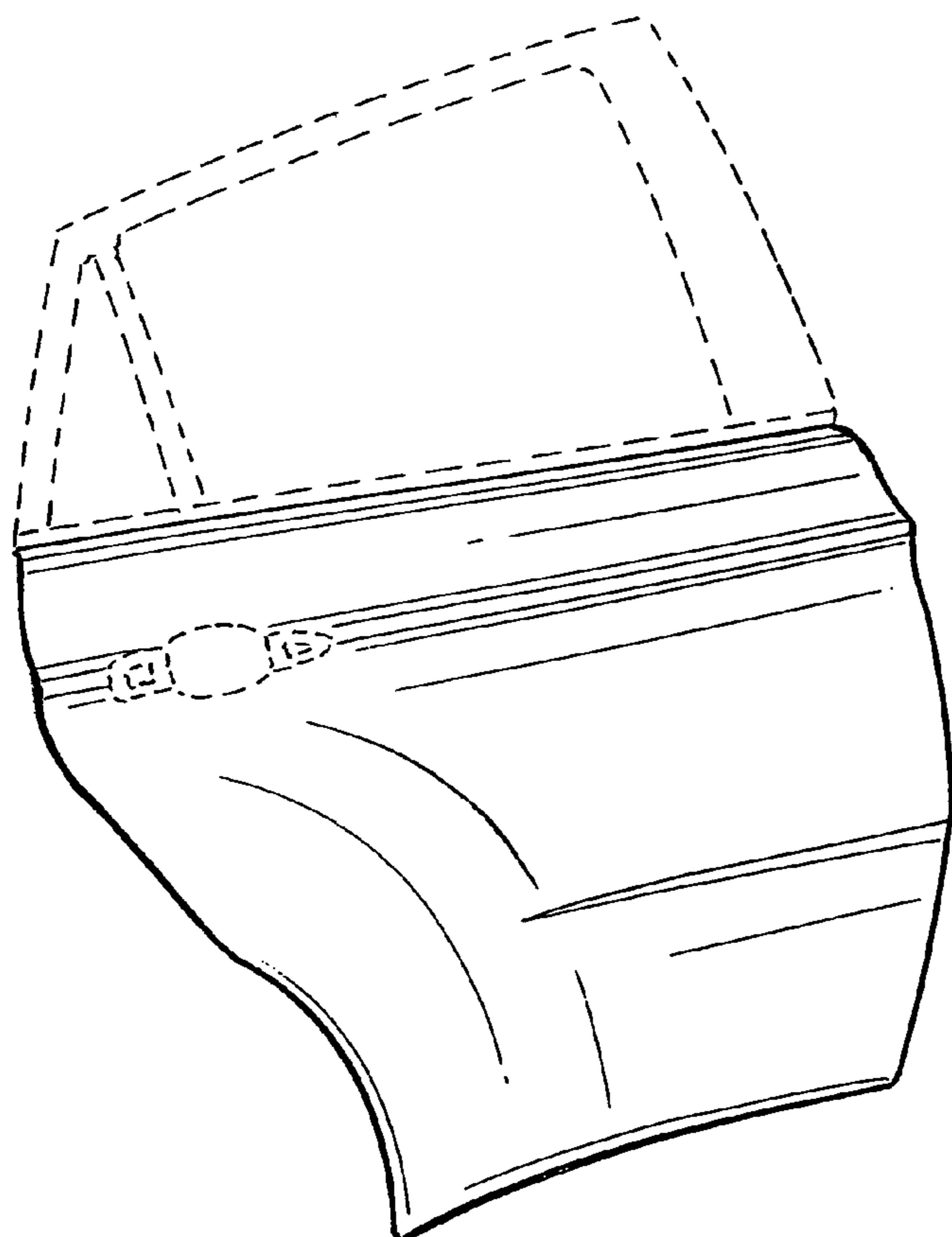

FIG. 7

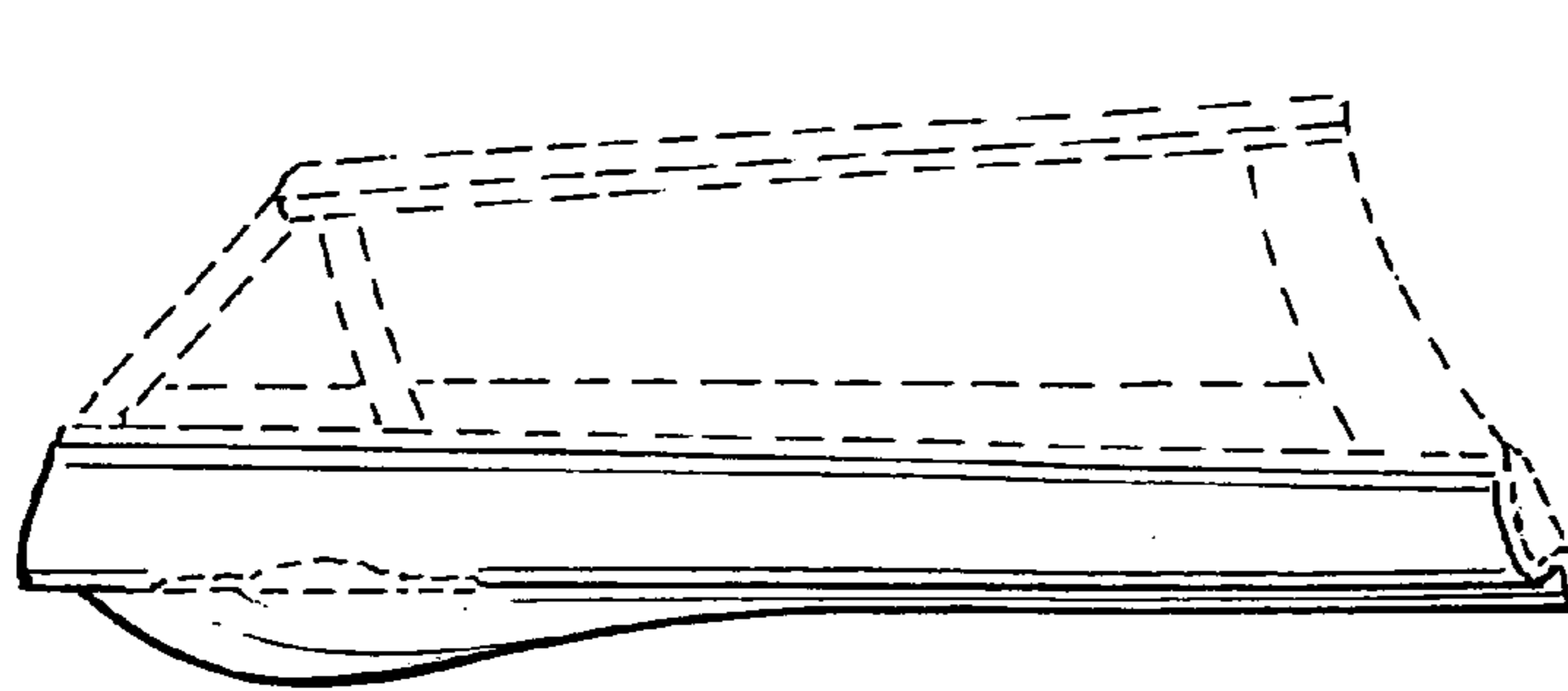
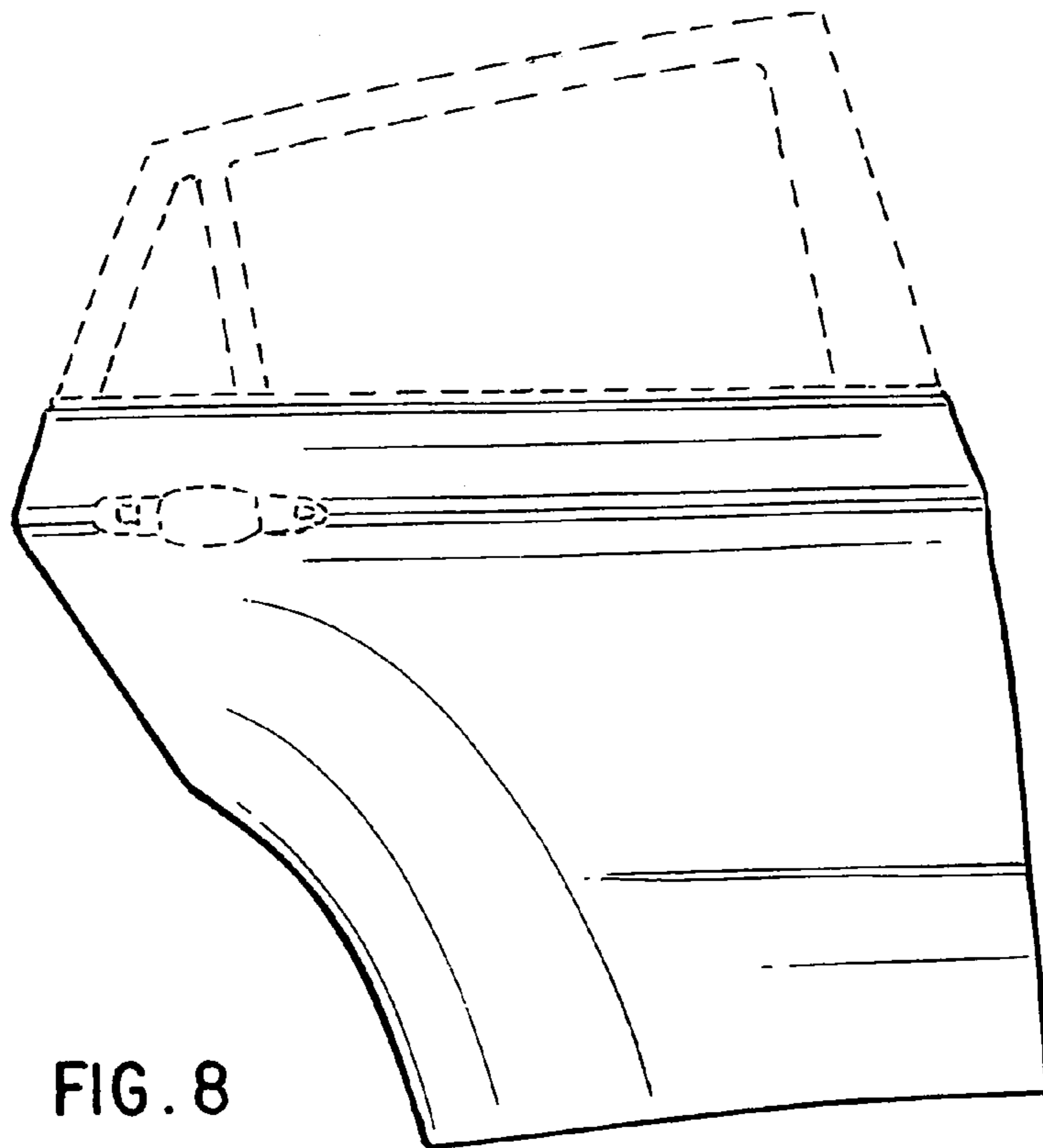

FIG. 10

