



US00D582897S

(12) **United States Design Patent**
Christopher et al.

(10) **Patent No.:** **US D582,897 S**

(45) **Date of Patent:** **** Dec. 16, 2008**

(54) **USER INTERFACE**

(75) Inventors: **Stephen M. Christopher**, Chicago, IL (US); **Scott H. Wilson**, Chicago, IL (US)

(73) Assignee: **Motorola, Inc.**, Schaumburg, IL (US)

(**) Term: **14 Years**

(21) Appl. No.: **29/276,960**

(22) Filed: **Feb. 9, 2007**

(51) **LOC (8) Cl.** **14-01**

(52) **U.S. Cl.** **D14/223**

(58) **Field of Classification Search** D14/205,
D14/206, 223; 379/430, 433.01, 433.02,
379/433.03; 381/380, 381, 370, 374-379;
D24/174; 455/575.2

See application file for complete search history.

(56) **References Cited**

U.S. PATENT DOCUMENTS

4,958,697	A *	9/1990	Moody	181/129
D430,146	S *	8/2000	Lin	D14/223
D452,492	S *	12/2001	Mori	D14/223
D471,898	S *	3/2003	Bae	D14/223
D494,570	S *	8/2004	Ma	D14/223
6,839,432	B1 *	1/2005	Martin	379/446
D538,271	S *	3/2007	Kim et al.	D14/223
D539,787	S *	4/2007	Kim et al.	D14/223
D552,596	S *	10/2007	Christopher	D14/205
D553,613	S *	10/2007	Sade et al.	D14/223
D554,626	S *	11/2007	Christopher	D14/223

D555,150	S *	11/2007	Christopher et al.	D14/223
D559,836	S *	1/2008	Lee	D14/223
D562,310	S *	2/2008	Moon et al.	D14/223
D566,108	S *	4/2008	Kan	D14/223
D568,302	S *	5/2008	Oh	D14/223
D573,983	S *	7/2008	Bang et al.	D14/223
D575,268	S *	8/2008	Christopher et al.	D14/205
D575,277	S *	8/2008	Gaarde et al.	D14/223

* cited by examiner

Primary Examiner—Paula Greene

(74) *Attorney, Agent, or Firm*—Hisashi D. Watanabe

(57) **CLAIM**

The ornamental design for a user interface, as shown and described.

DESCRIPTION

FIG. 1 is a perspective view of a user interface showing our new design;

FIG. 2 is a front elevational view thereof;

FIG. 3 is a rear elevational view thereof;

FIG. 4 is a first side elevational view thereof;

FIG. 5 is a second side elevational view thereof;

FIG. 6 is a top view thereof; and,

FIG. 7 is a bottom view thereof.

The broken lines shown in FIGS. 1-7 are included for the purpose of illustrating environmental elements only and form no part of the claimed design.

1 Claim, 5 Drawing Sheets

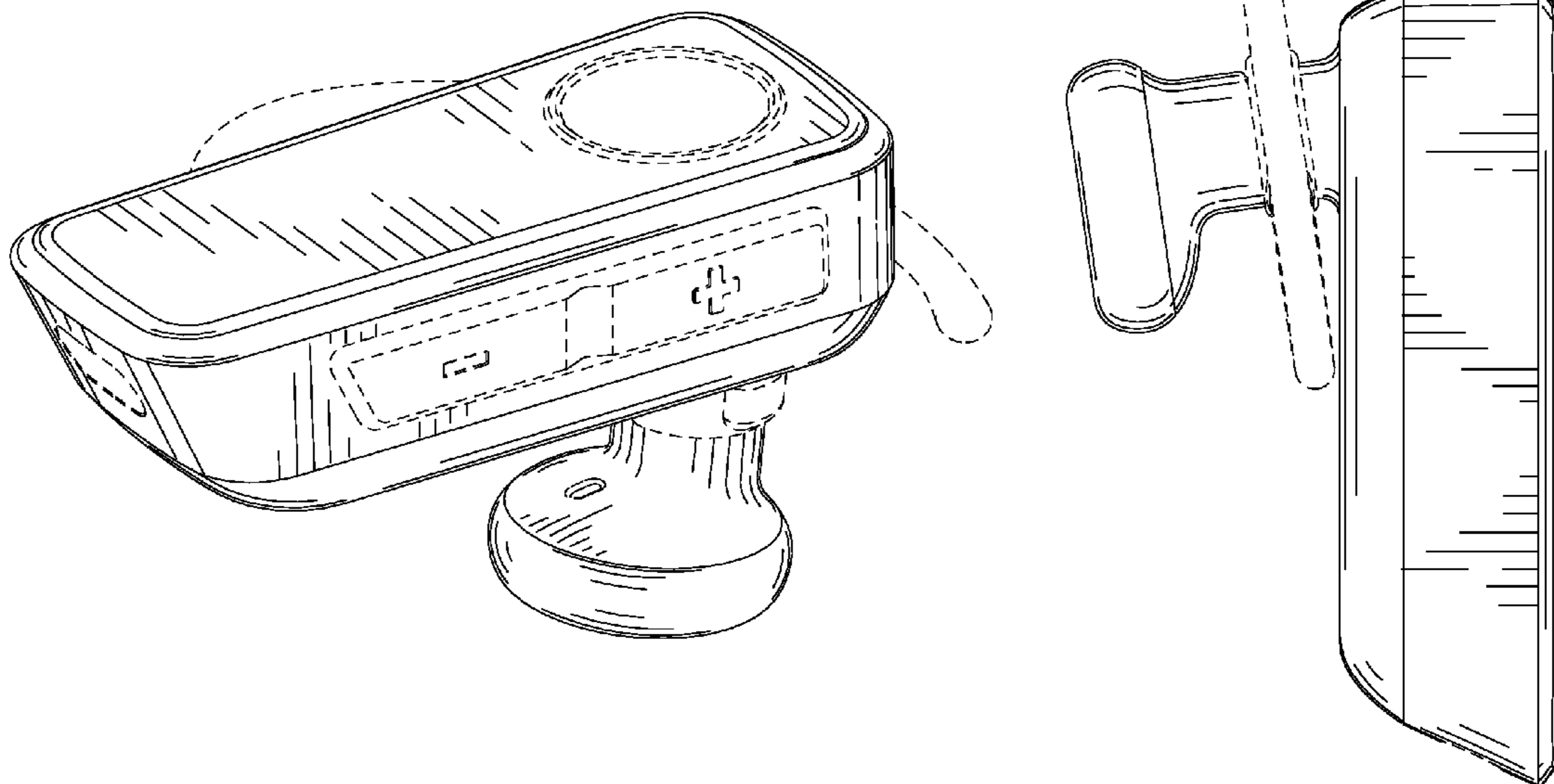

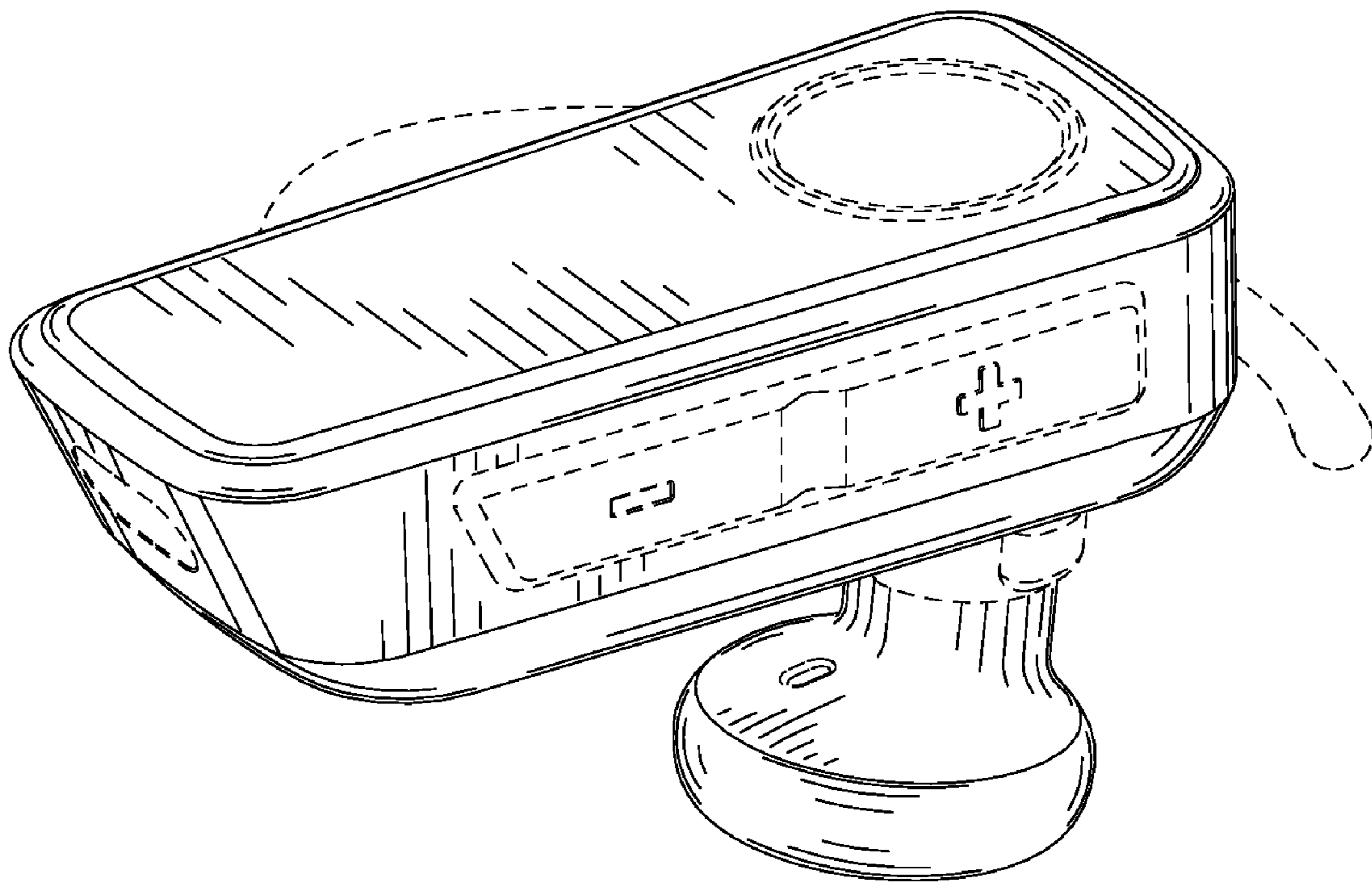

FIG. 1

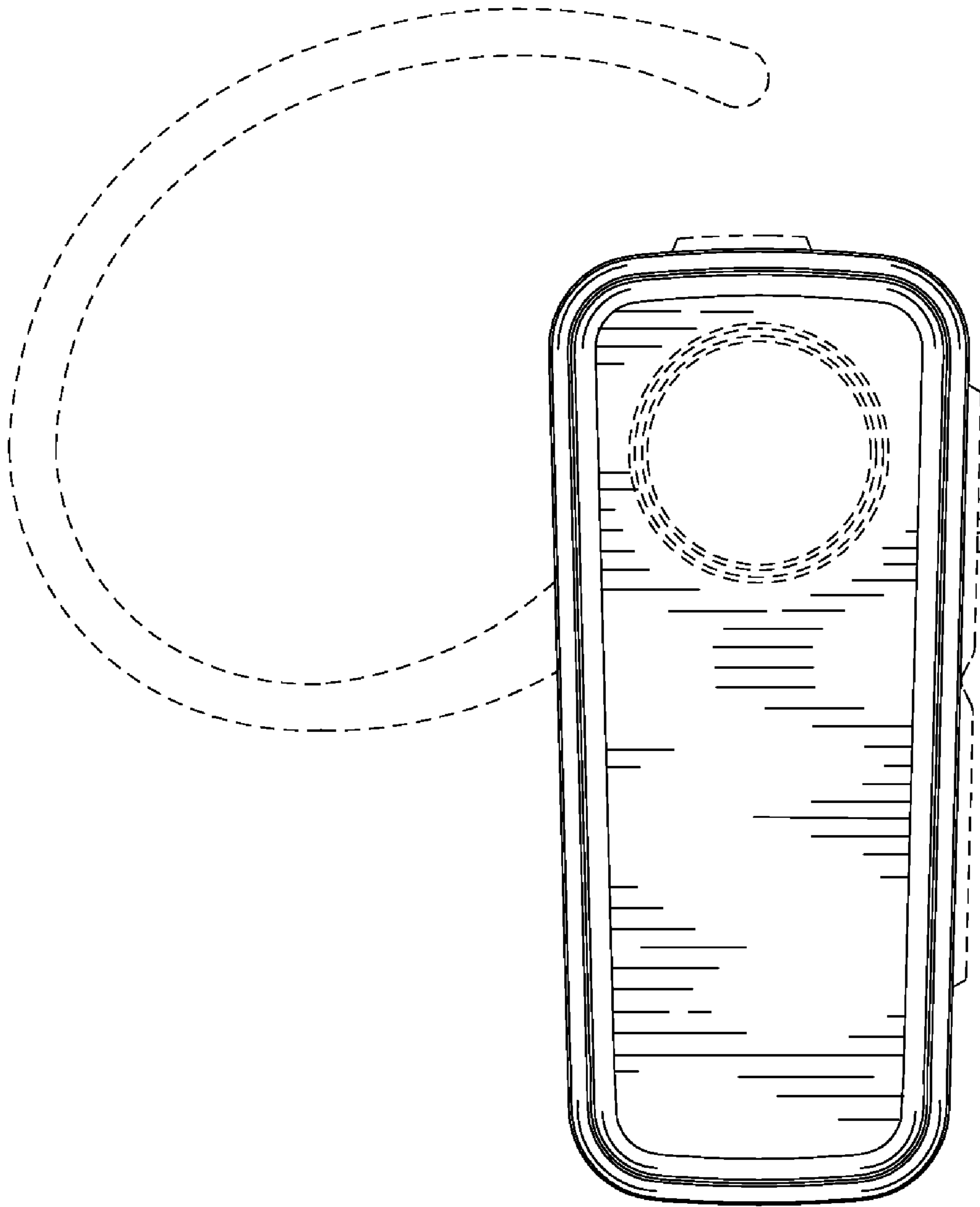

FIG. 2

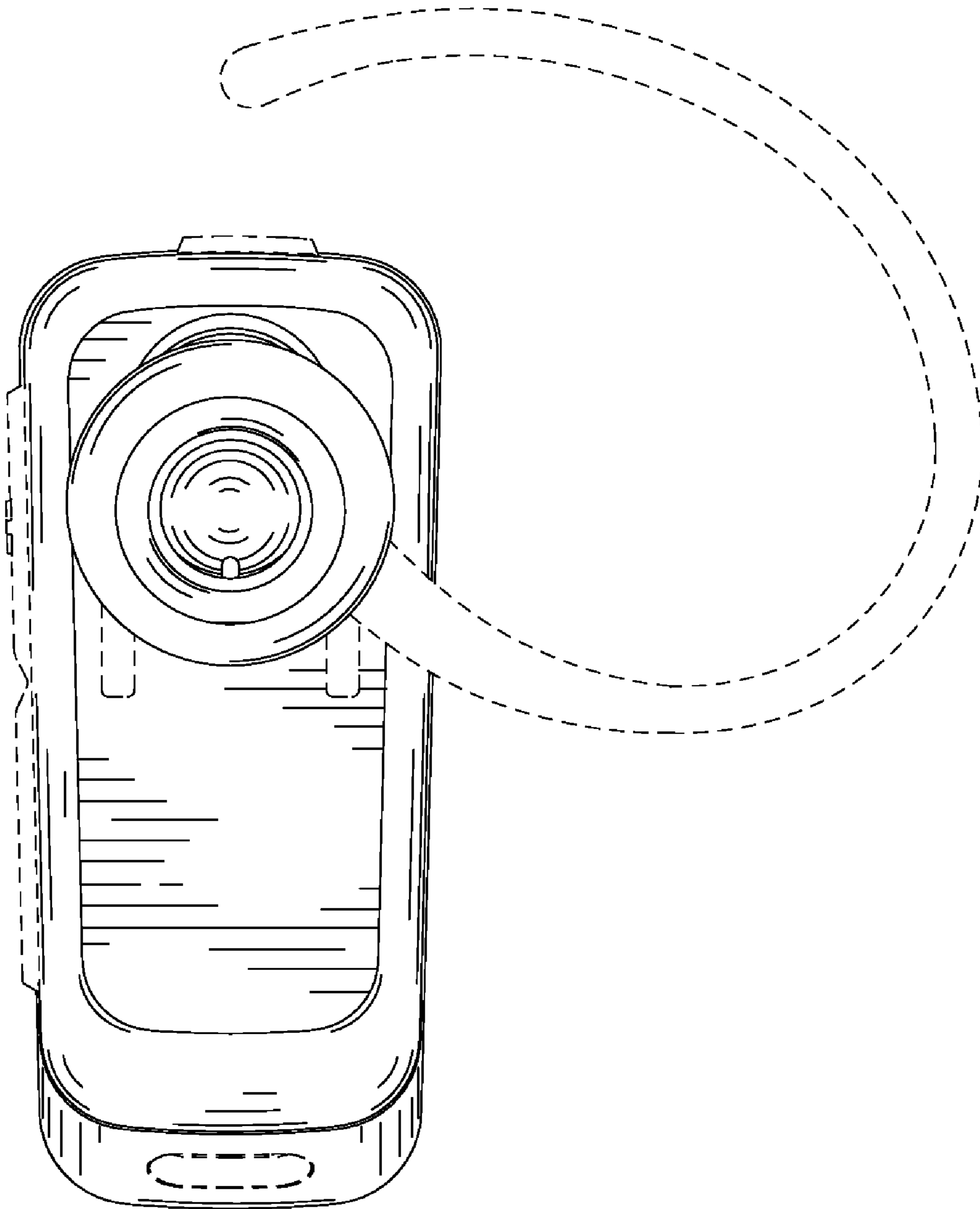

FIG. 3

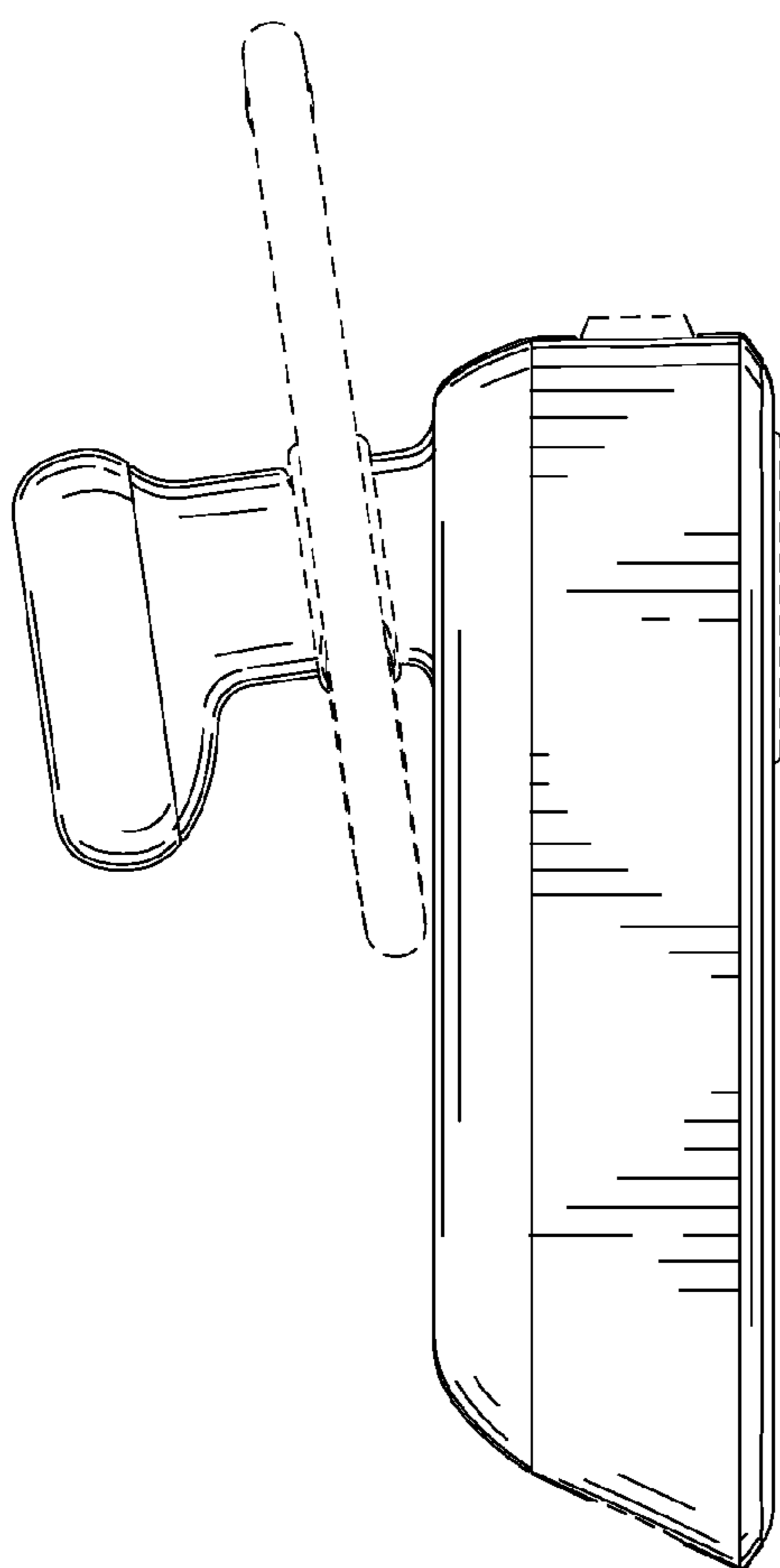

FIG. 4

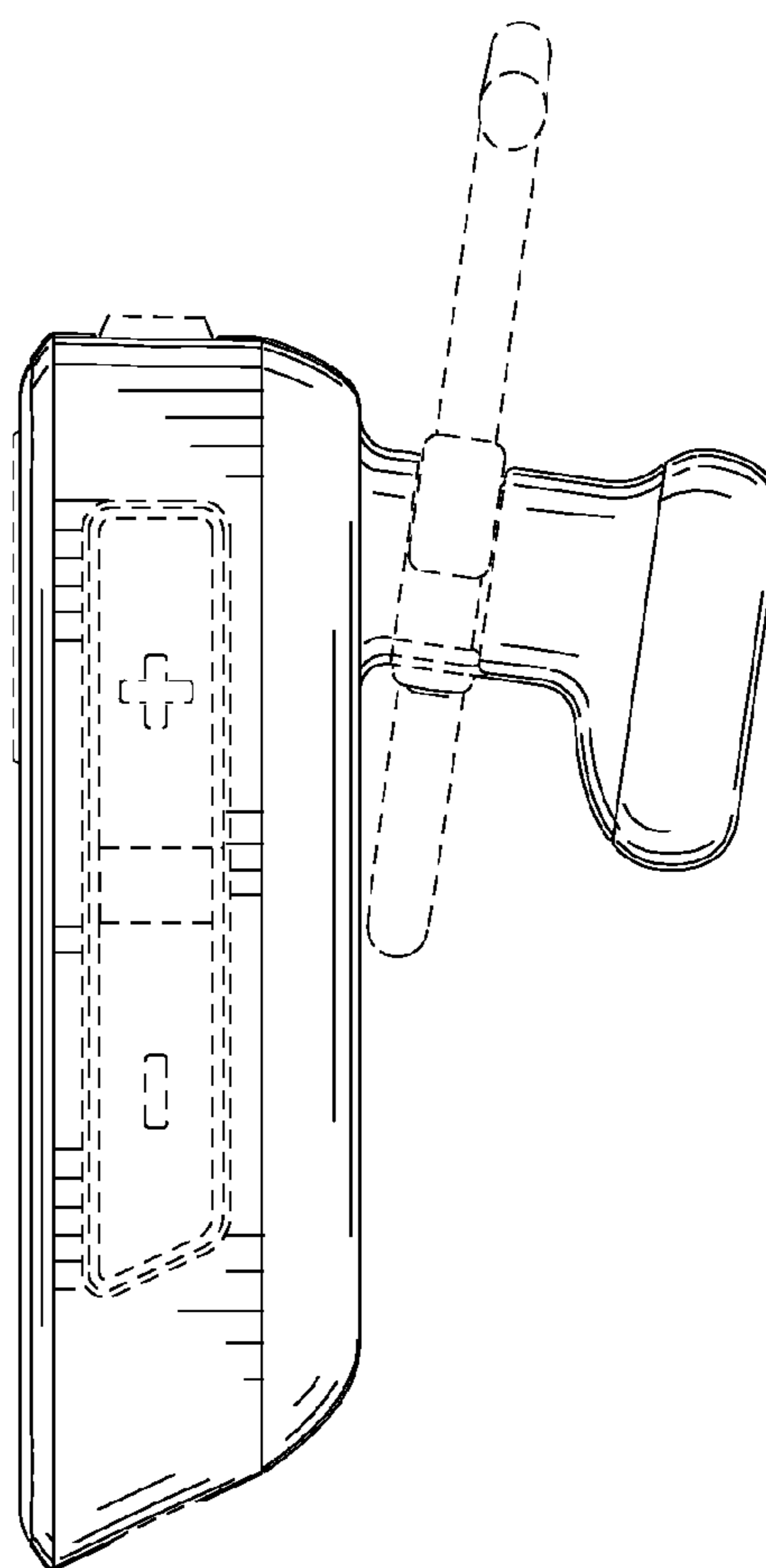

FIG. 5

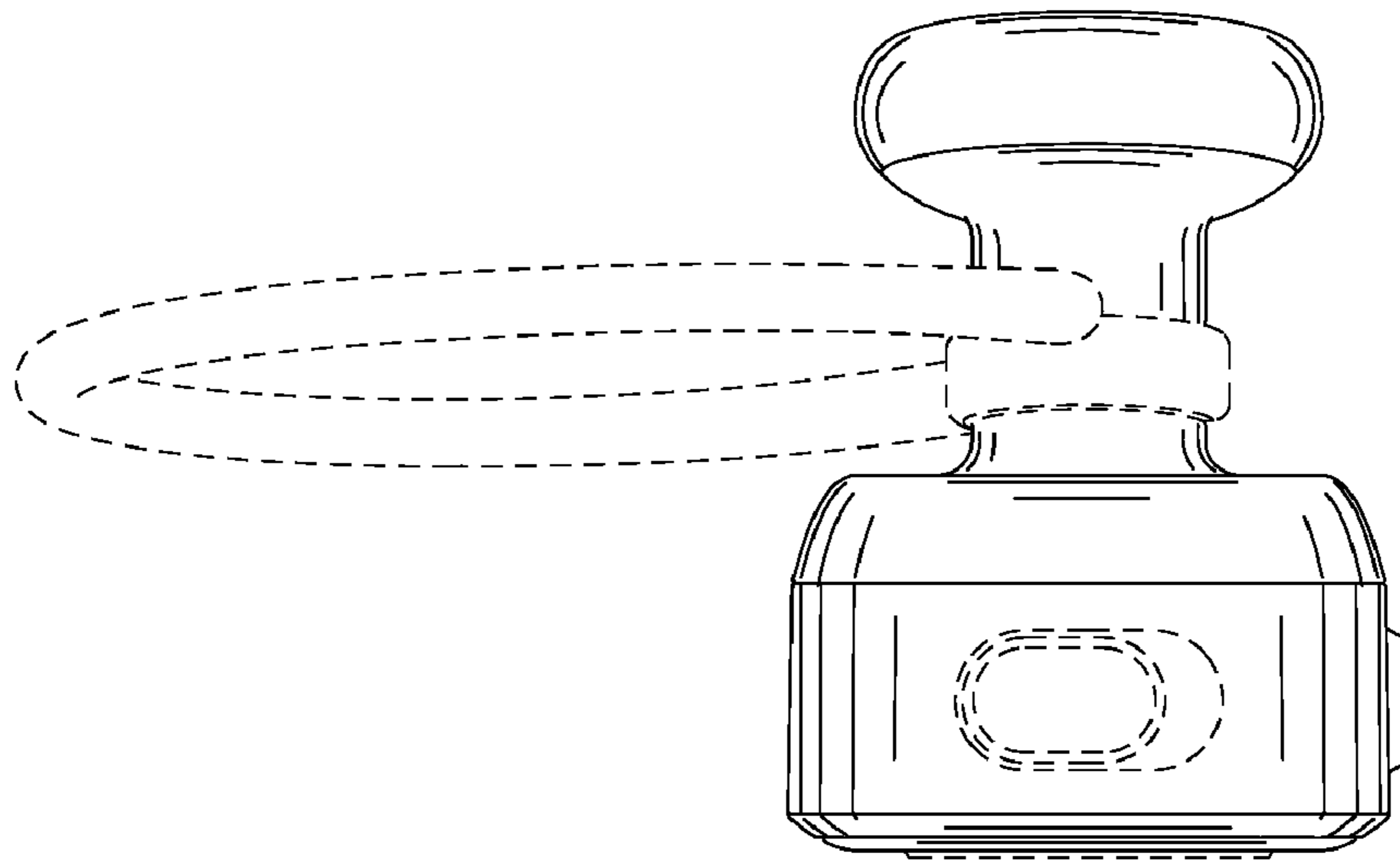

FIG. 6

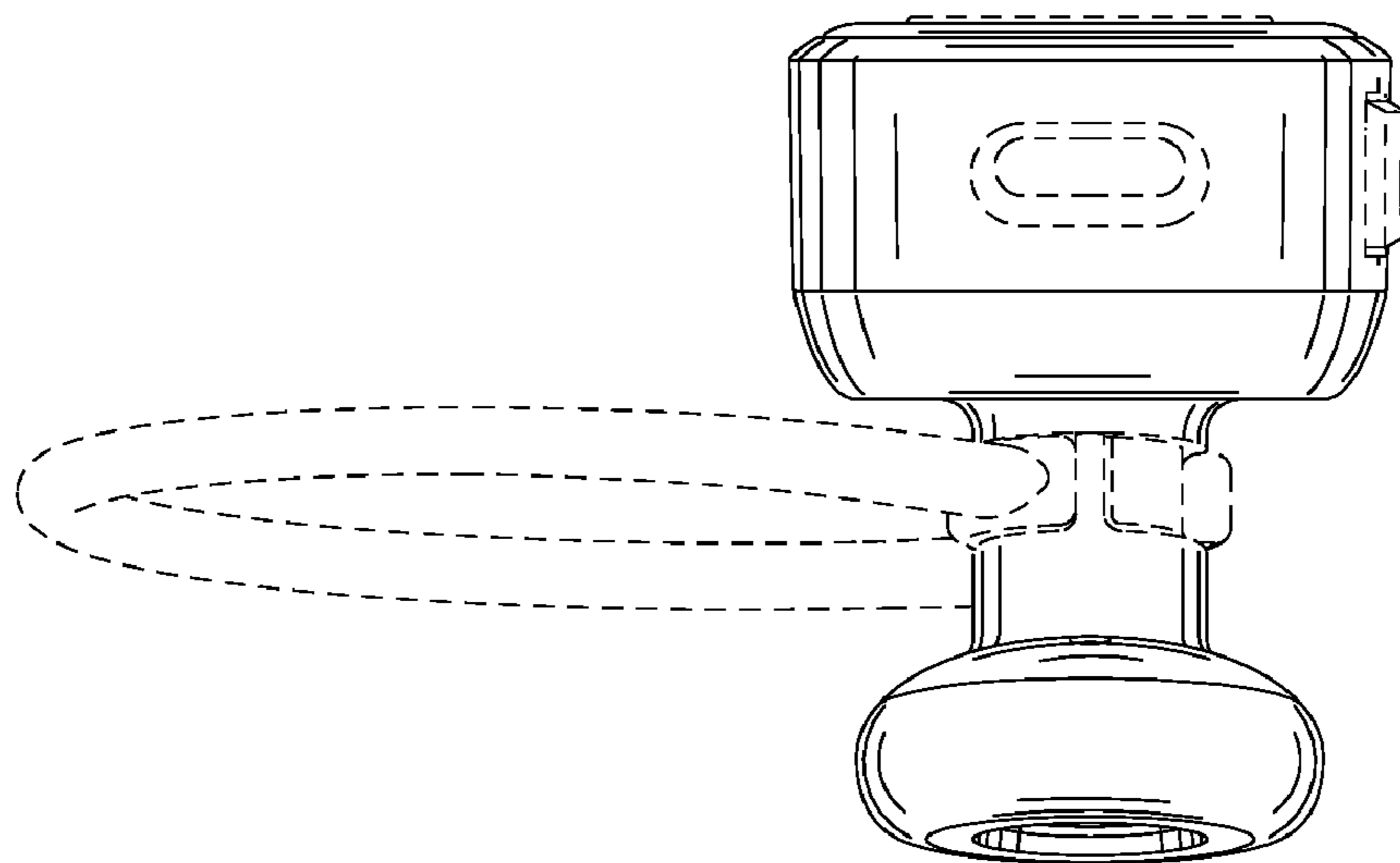

FIG. 7