



US00D582862S

(12) **United States Design Patent**
Landerholm et al.

(10) **Patent No.:** **US D582,862 S**

(45) **Date of Patent:** **** Dec. 16, 2008**

(54) **CONTROL UNIT**

(75) Inventors: **John Landerholm**, Århus C (DK);
Peter Boldsen Lund, Århus C (DK)

(73) Assignee: **Linak A/S**, Nordborg (DK)

(**) Term: **14 Years**

(21) Appl. No.: **29/309,251**

(22) Filed: **Jul. 14, 2008**

Related U.S. Application Data

(62) Division of application No. 29/290,328, filed on Nov. 20, 2007, now Pat. No. Des. 575,240.

(30) **Foreign Application Priority Data**

May 21, 2007 (DK) DA 2007 00131

(51) **LOC (8) Cl.** **13-03**

(52) **U.S. Cl.** **D13/162; D13/164**

(58) **Field of Classification Search** D13/162,
D13/164, 184; D14/240; 174/50, 52.1, 58;
312/223.1, 223.2; 220/3.2, 3.8, 4.02; 361/679,
361/692, 695, 724, 730; D10/65; D24/185,
D24/186

See application file for complete search history.

(56) **References Cited**

U.S. PATENT DOCUMENTS

- D367,430 S * 2/1996 Greenberg et al. D10/49
- D400,539 S * 11/1998 Hippen D14/218
- D513,497 S * 1/2006 Whitehouse D13/162
- D518,744 S * 4/2006 Rosen D10/50
- D558,152 S * 12/2007 Tatsuyama et al. D13/162
- D566,597 S * 4/2008 Schneor D10/103

* cited by examiner

Primary Examiner—Daniel D Bui

Assistant Examiner—Thomas J Johannes

(74) *Attorney, Agent, or Firm*—Dykema Gossett PLLC

(57) **CLAIM**

The ornamental design for a control unit, as shown and described.

DESCRIPTION

FIG. 1 is a front perspective view of a first embodiment of a control unit showing our design,

FIG. 2 is a rear perspective view thereof,

FIG. 3 is a front elevational view thereof,

FIG. 4 is a rear elevational view thereof,

FIG. 5 is a top plan view thereof,

FIG. 6 is a bottom plan view thereof,

FIG. 7 is a right side elevational view thereof, and

FIG. 8 is a left side elevational view thereof,

FIG. 9 is a front perspective view of a second embodiment of a control unit showing our design,

FIG. 10 is a rear perspective view thereof,

FIG. 11 is a front elevational view thereof,

FIG. 12 is a rear elevational view thereof,

FIG. 13 is a top plan view thereof,

FIG. 14 is a bottom plan view thereof,

FIG. 15 is a right side elevational view thereof; and,

FIG. 16 is a left side elevational view thereof.

The broken line portion of the figure drawings is included to show unclaimed subject matter only and forms no part of the claimed design.

1 Claim, 6 Drawing Sheets

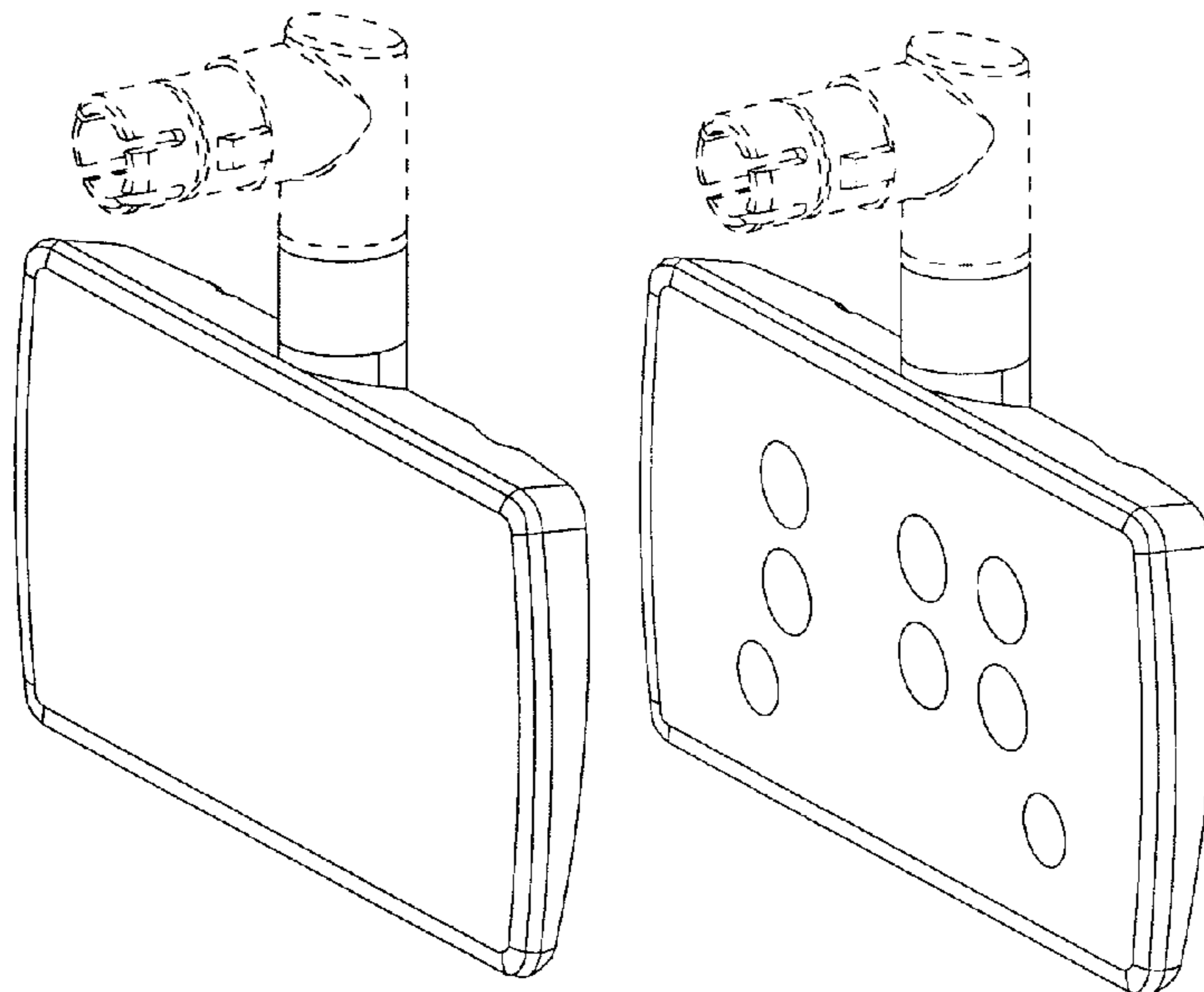

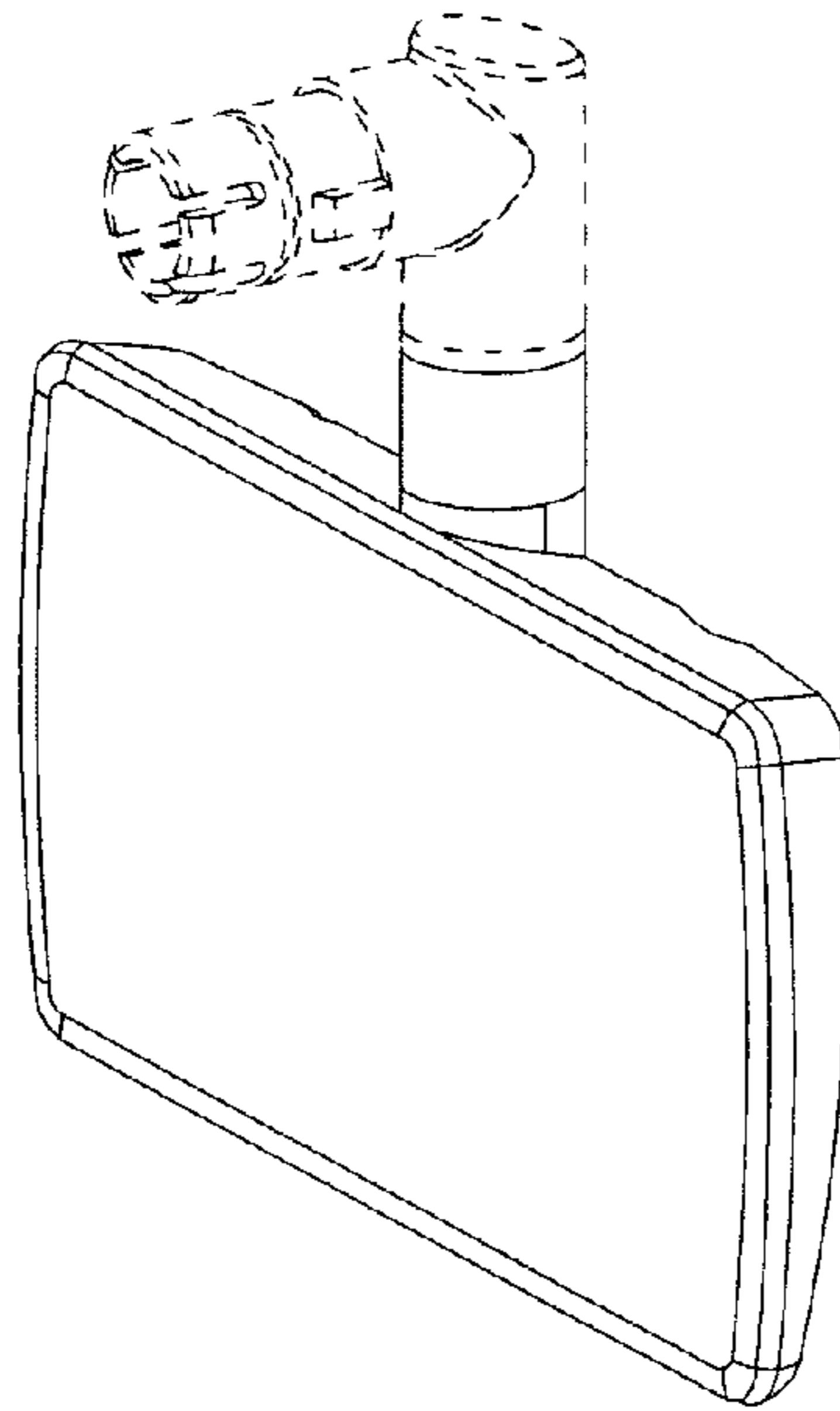

FIG. 1

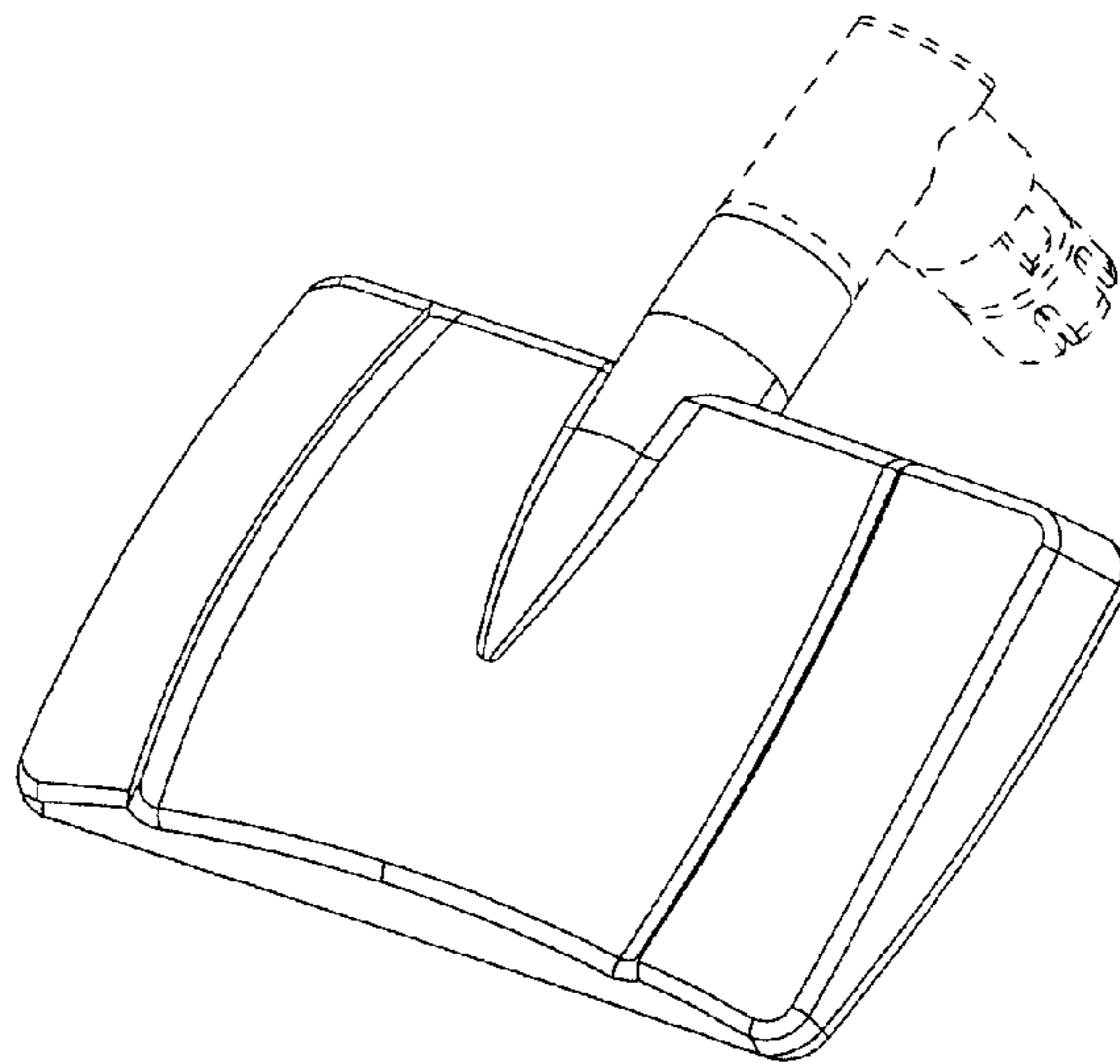

FIG. 2

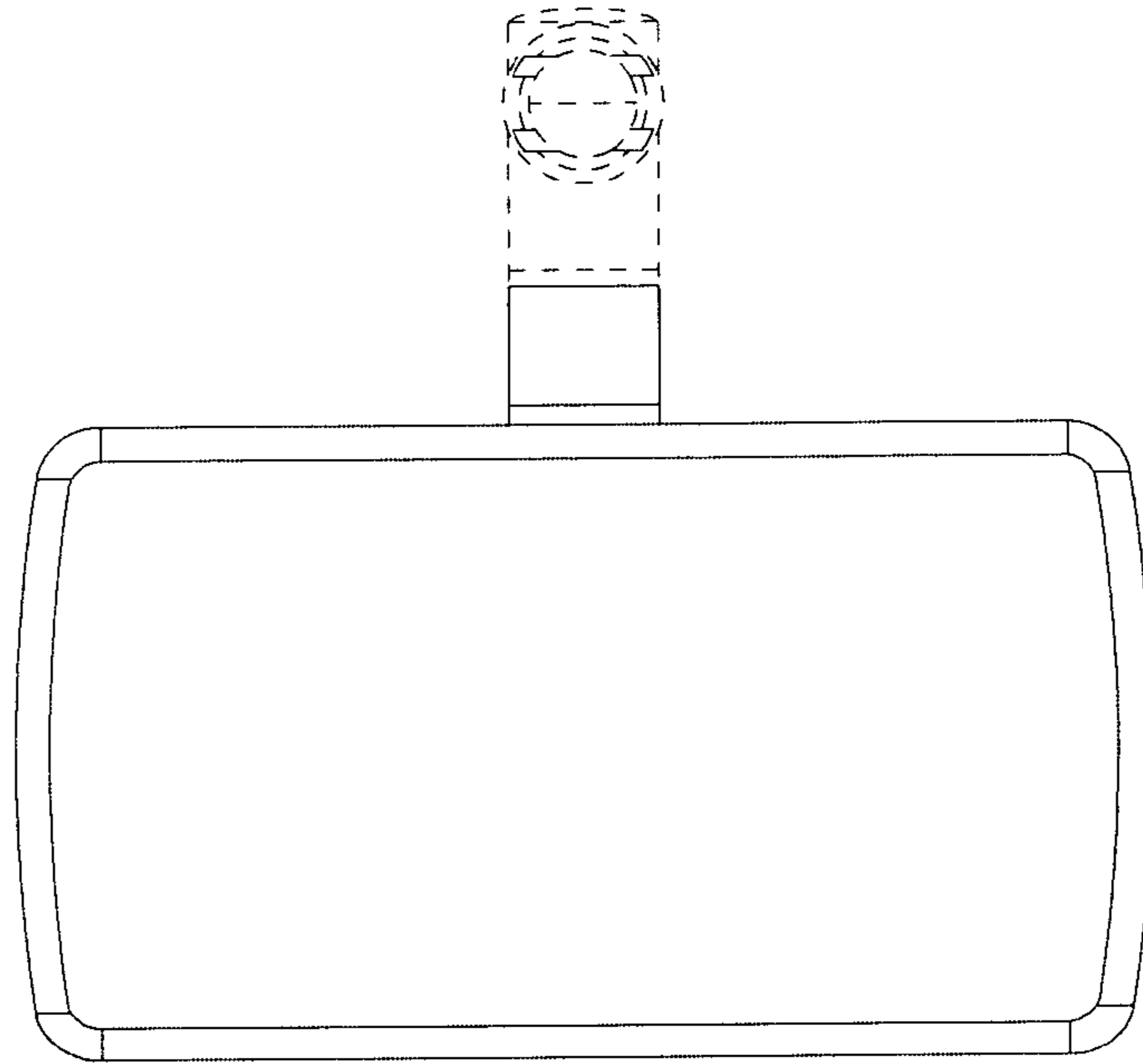

FIG. 3

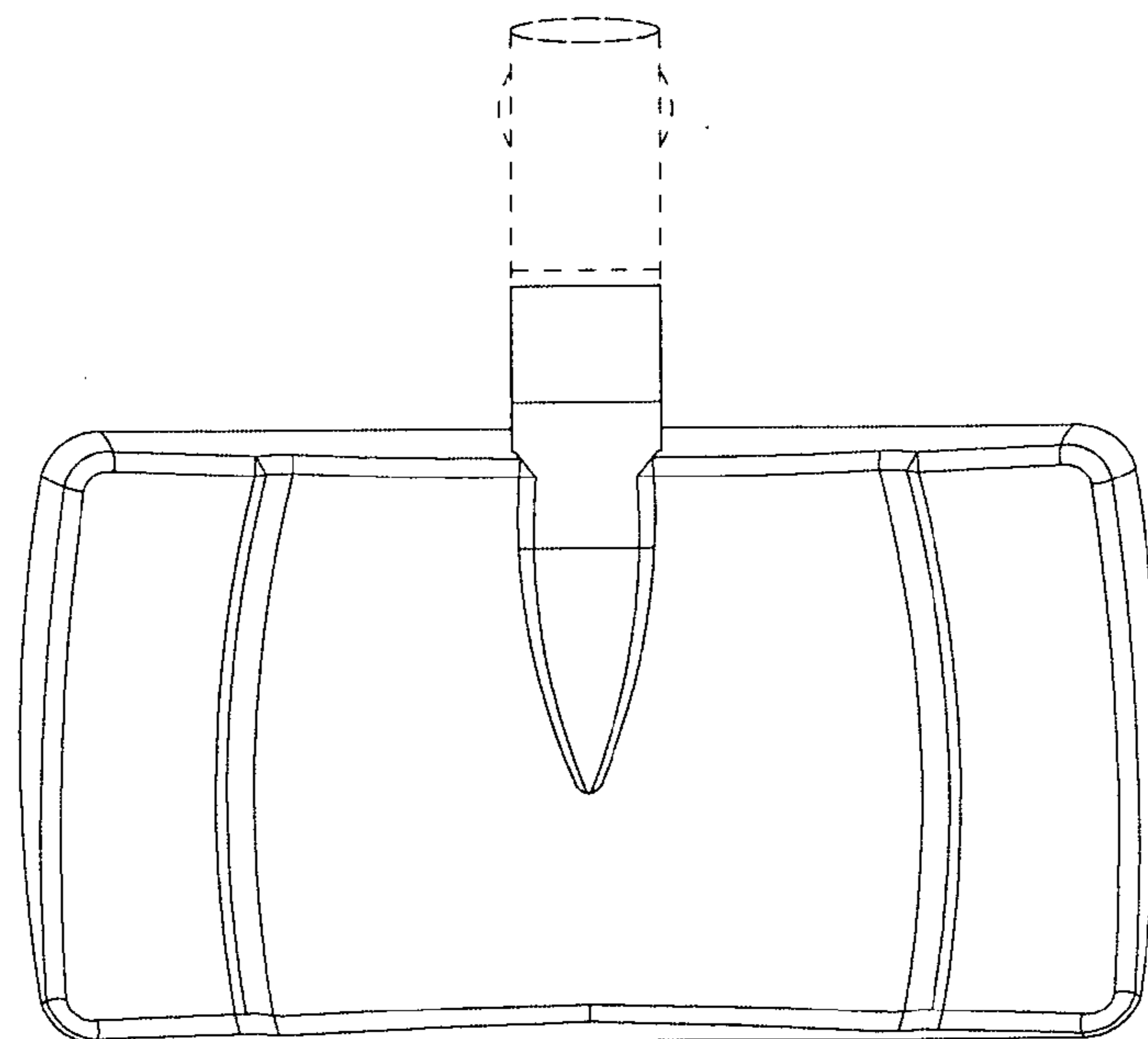

FIG. 4

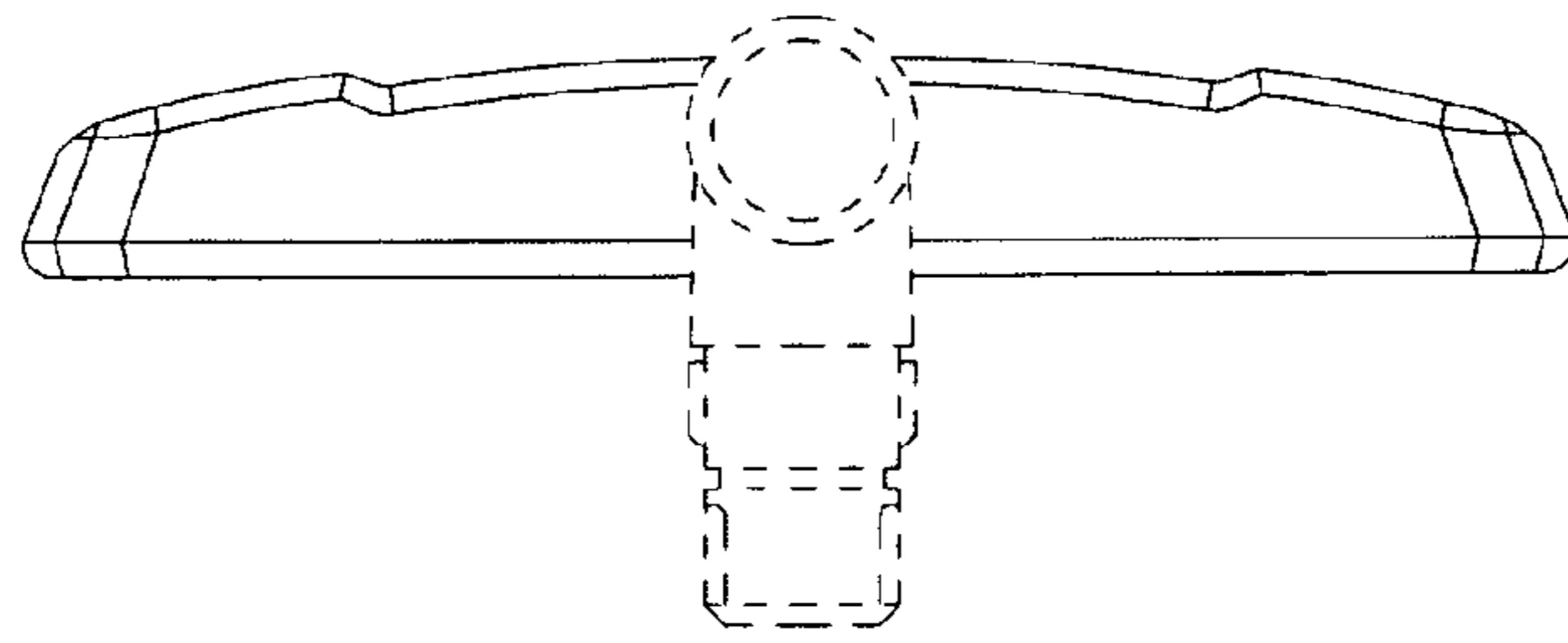

FIG. 5

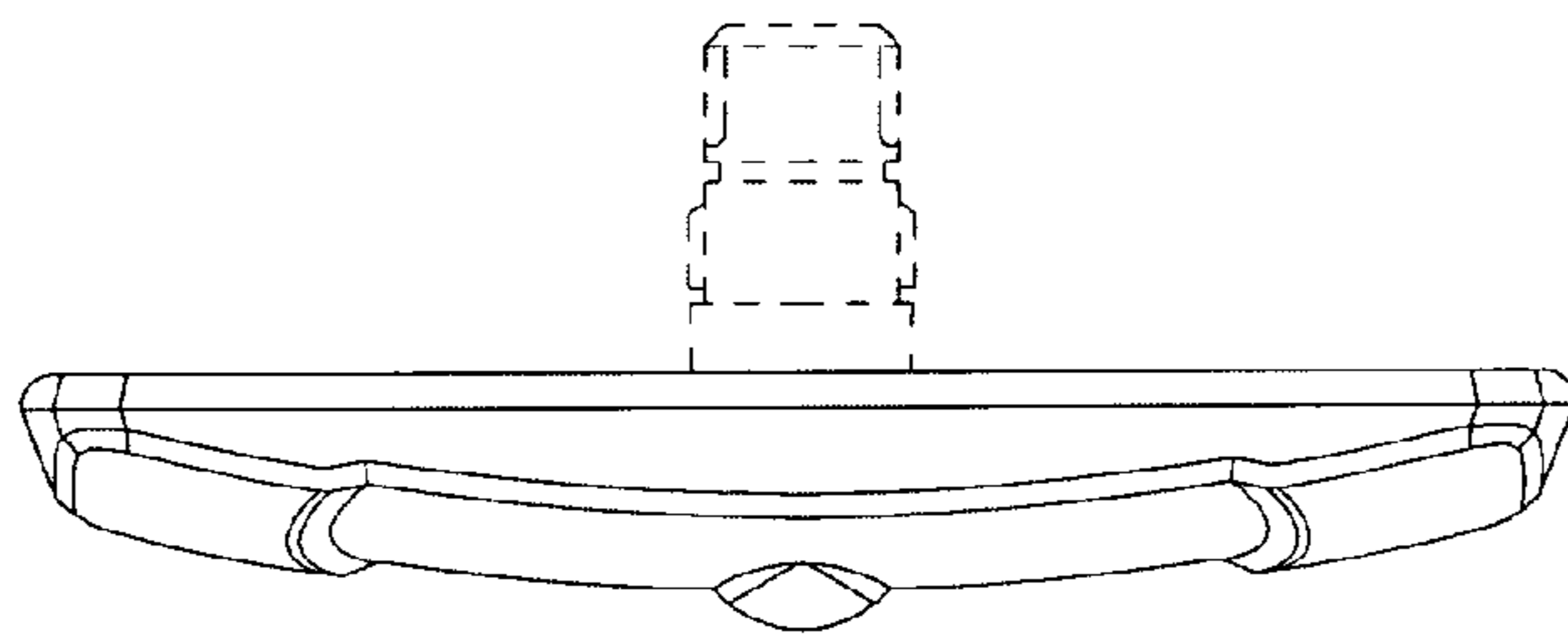

FIG. 6

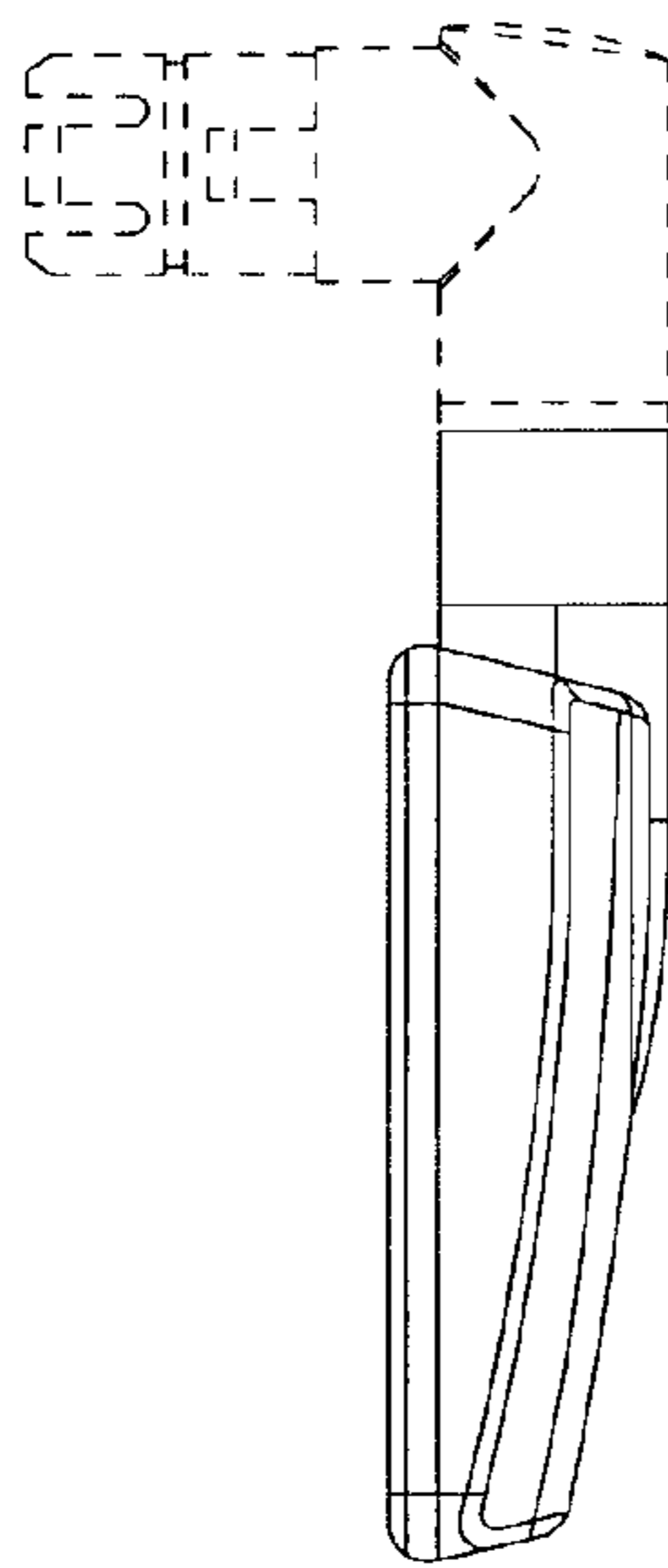

FIG. 7

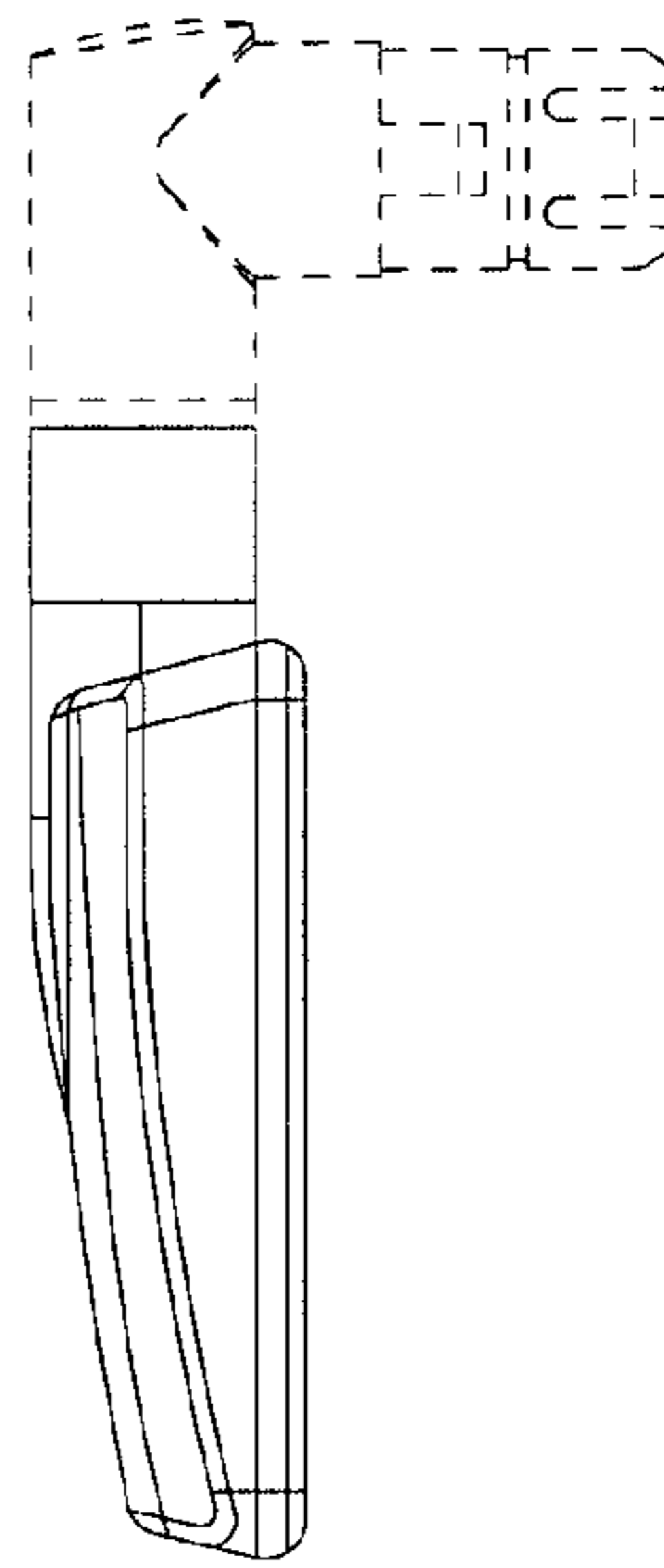

FIG. 8

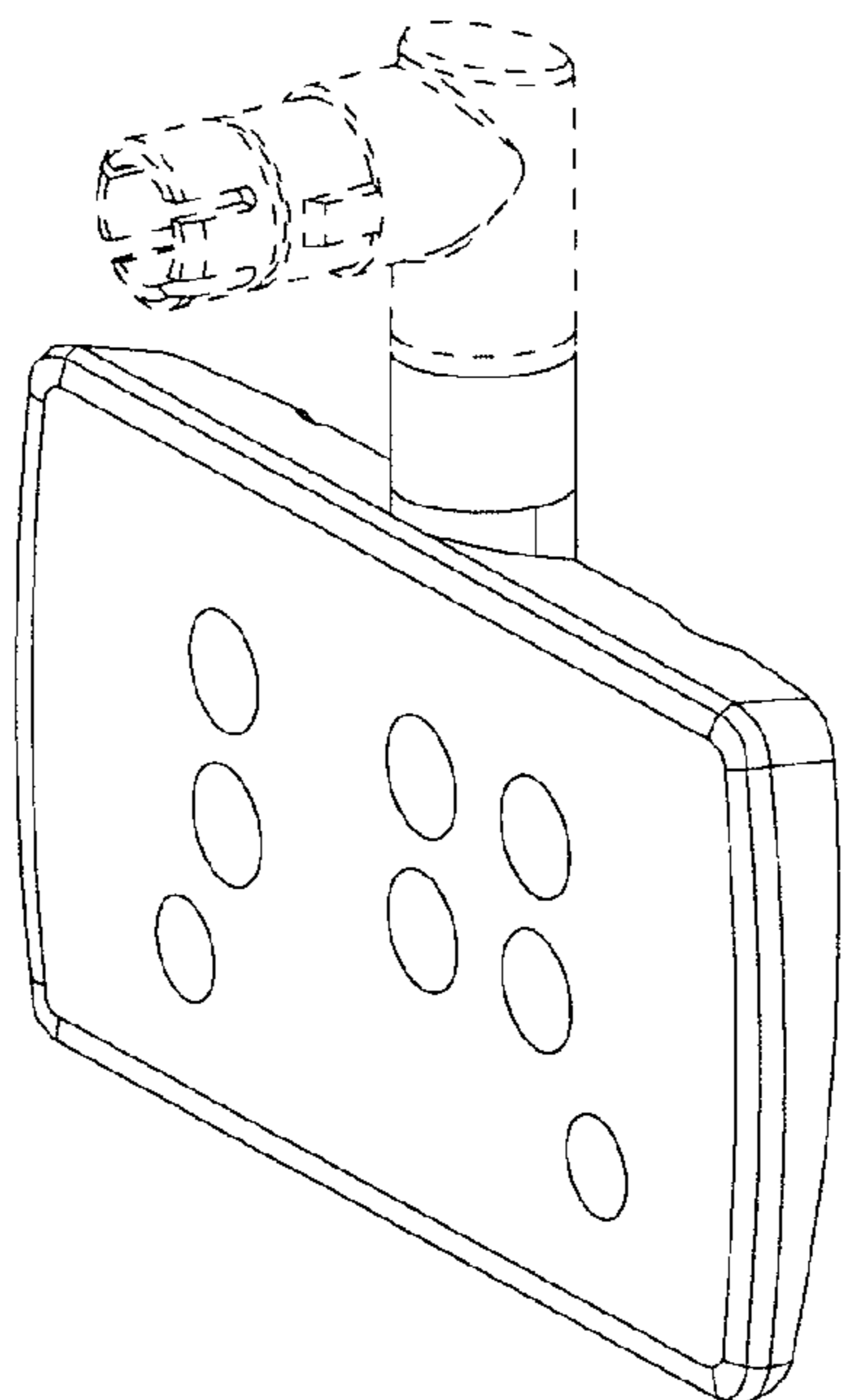

FIG. 9

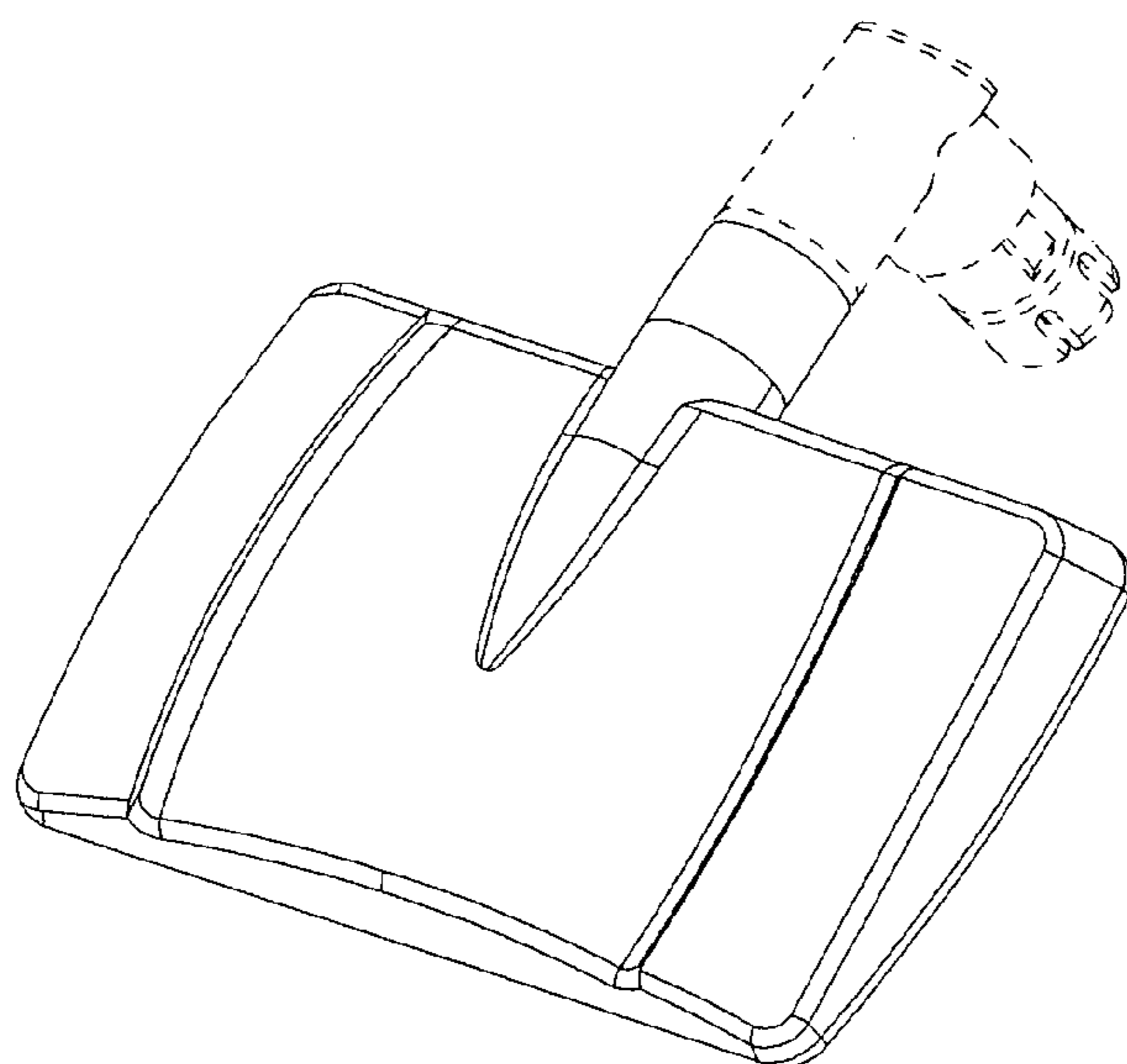

FIG. 10

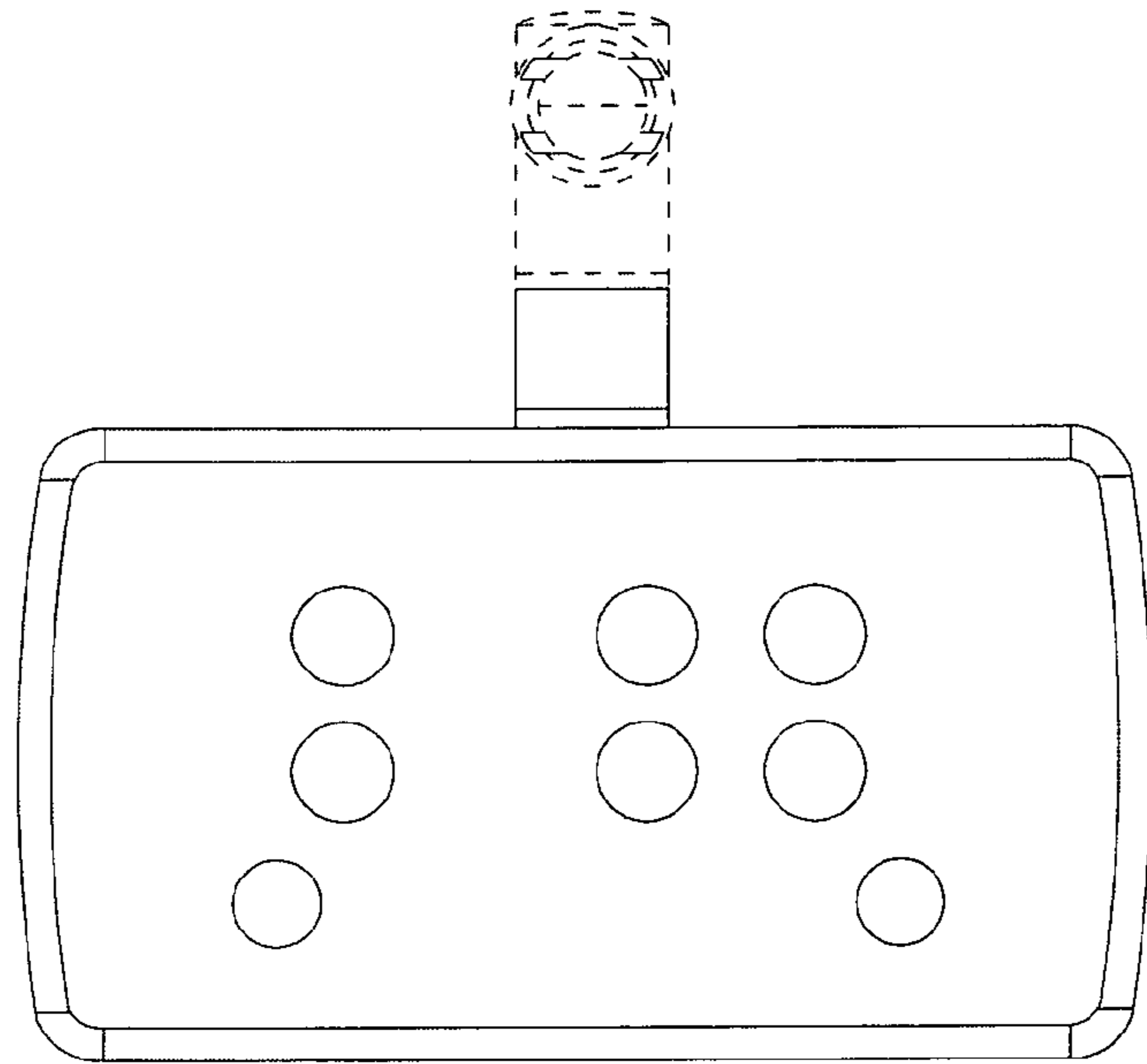

FIG. 11

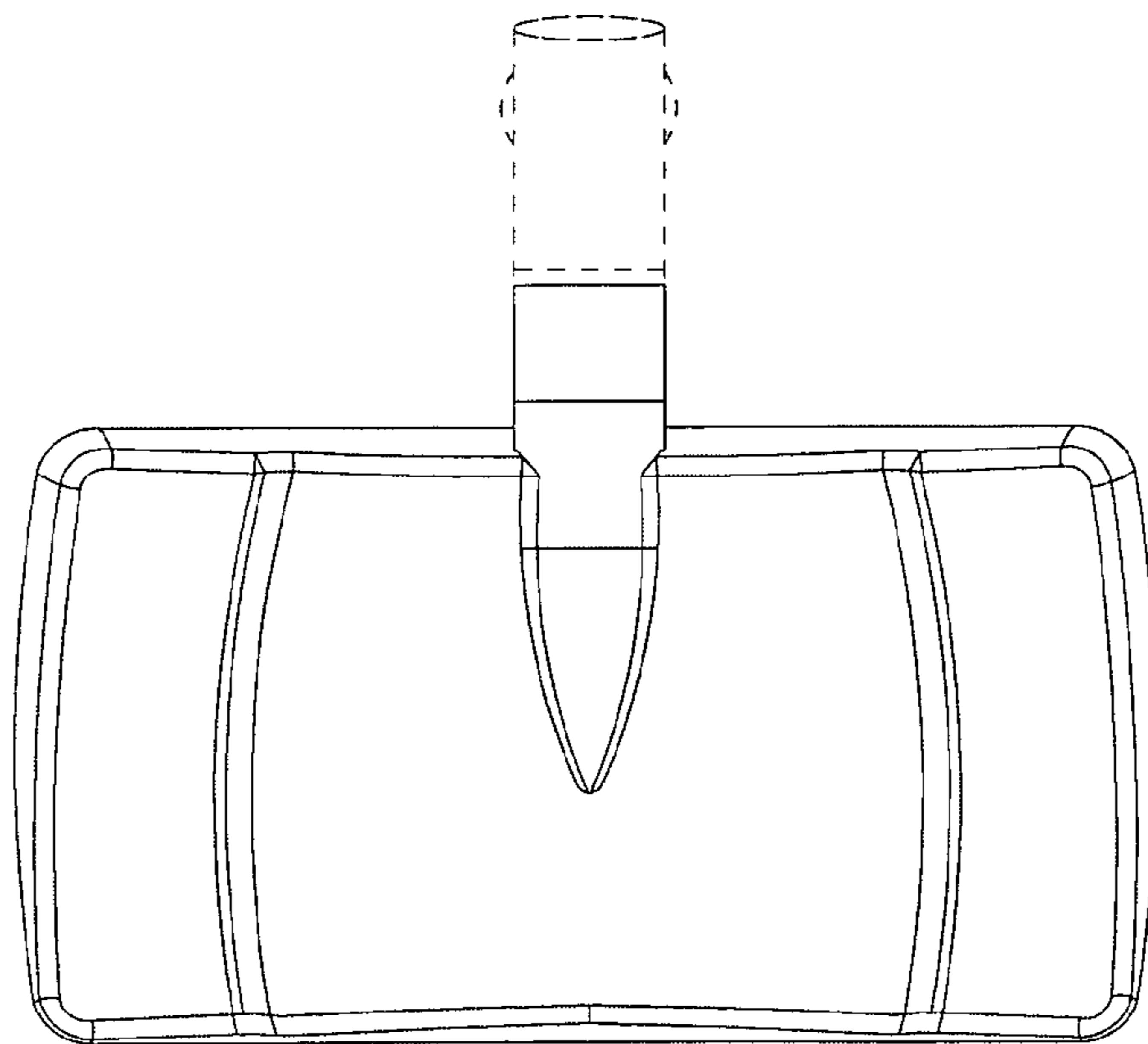

FIG. 12

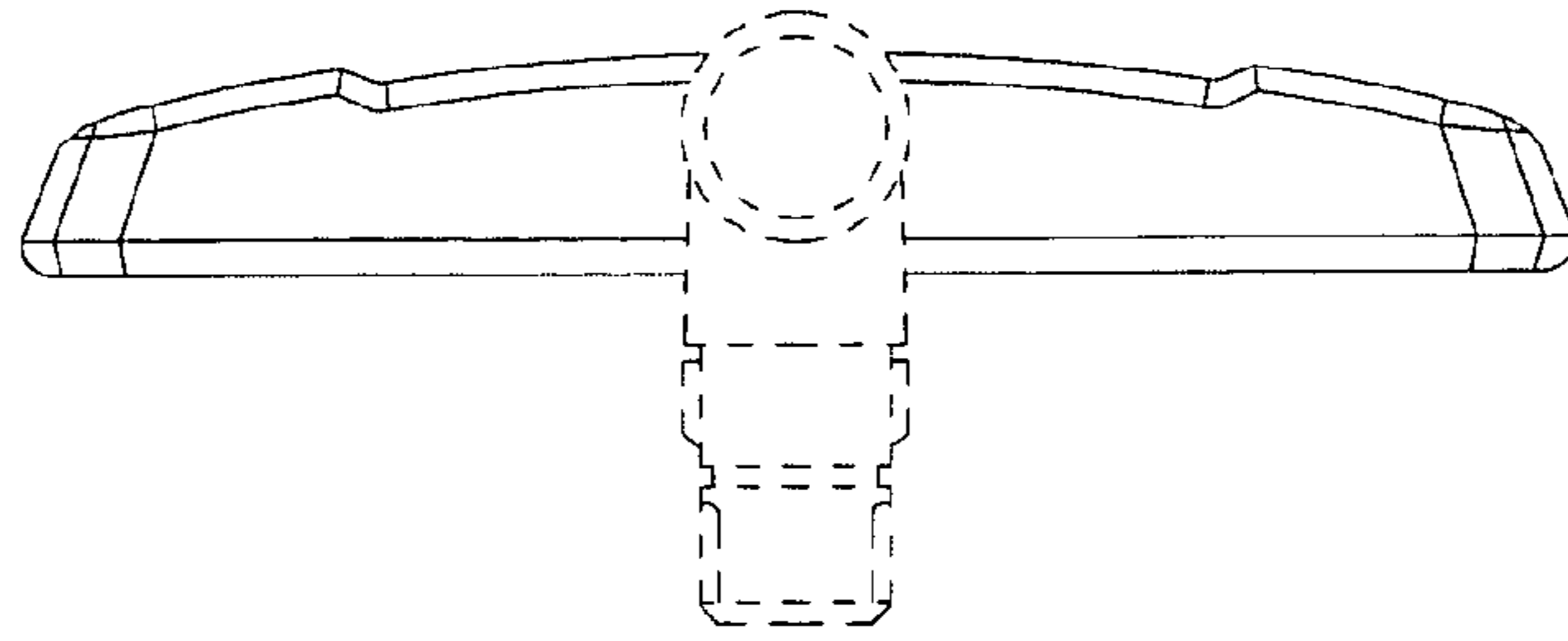

FIG. 13

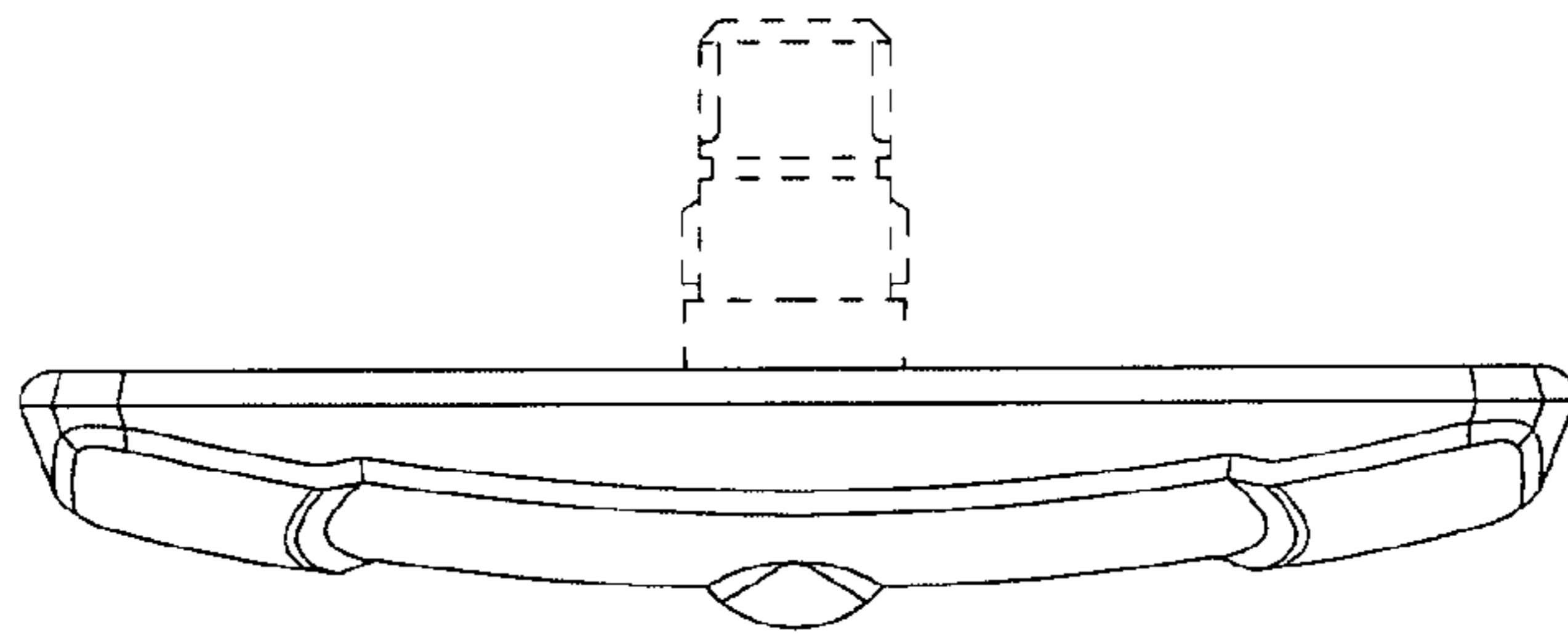

FIG. 14

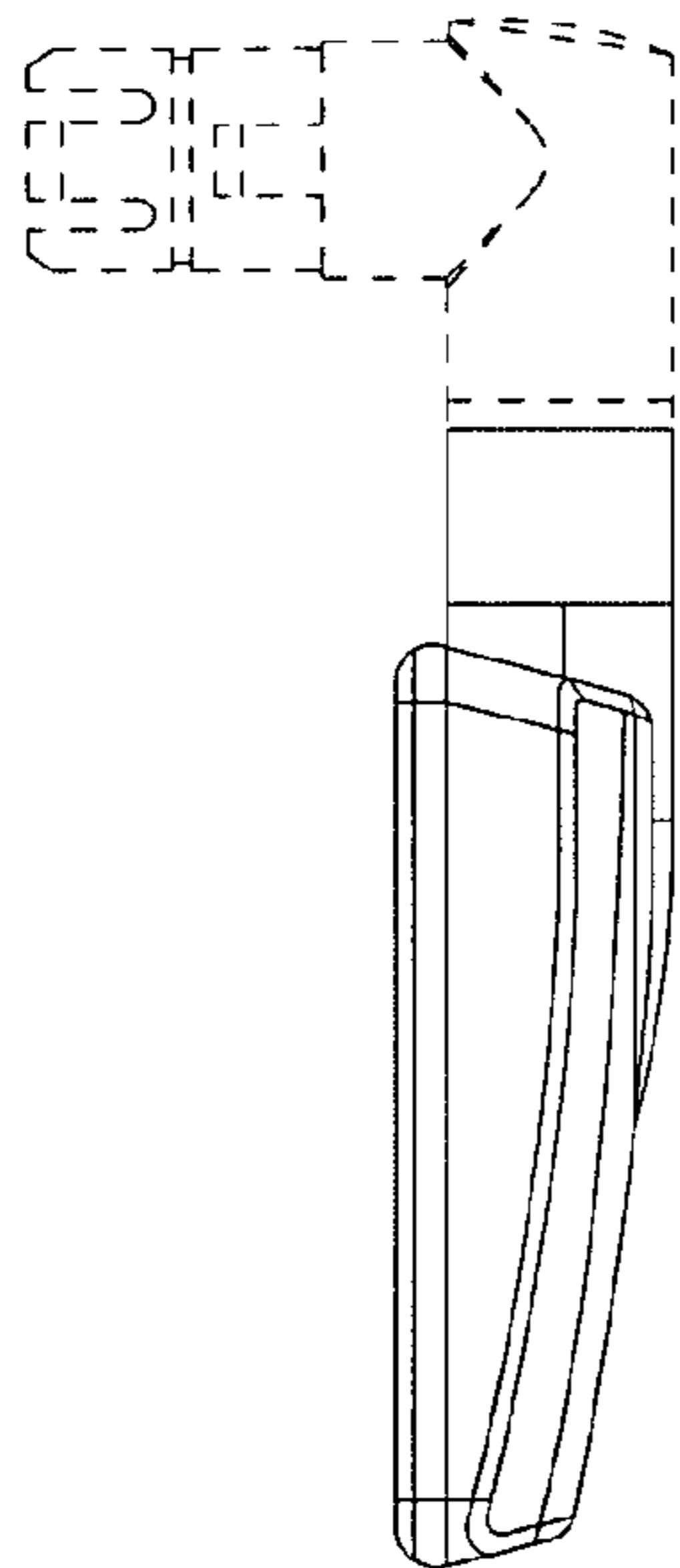

FIG. 15

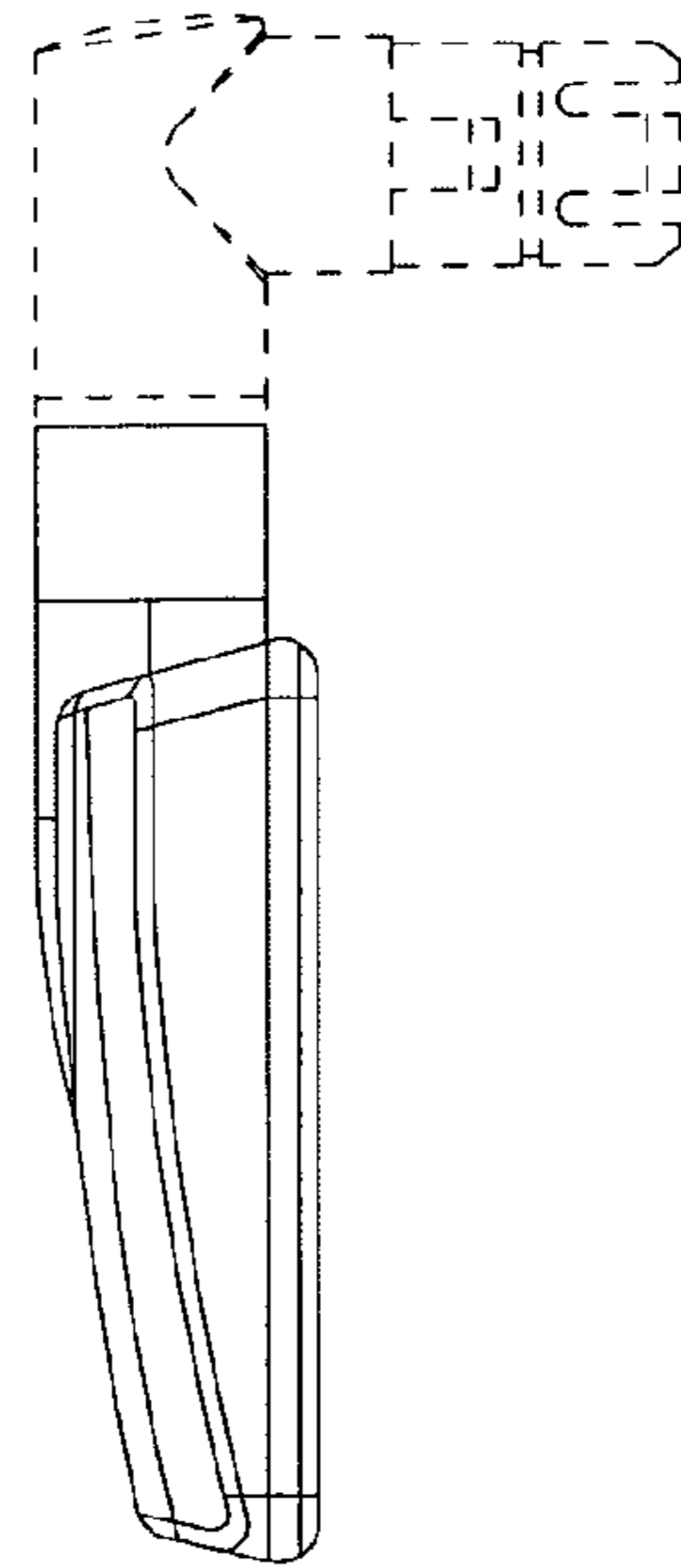

FIG. 16