



US00D582845S

(12) **United States Design Patent**
O'Hern

(10) **Patent No.:** **US D582,845 S**

(45) **Date of Patent:** **** Dec. 16, 2008**

(54) **INVERTER**

(75) Inventor: **Adam M. O'Hern**, Cambridge, MA
(US)

(73) Assignee: **Black & Decker Inc.**, Newark, DE (US)

(**) Term: **14 Years**

(21) Appl. No.: **29/296,134**

(22) Filed: **Oct. 15, 2007**

(51) **LOC (8) Cl.** **13-02**

(52) **U.S. Cl.** **D13/110**

(58) **Field of Classification Search** D13/110,
D13/123, 184, 199; 307/149, 150; 361/600,
361/601, 730; 363/141, 142

See application file for complete search history.

(56) **References Cited**

U.S. PATENT DOCUMENTS

2,332,682	A	10/1943	Yelinek	
2,771,780	A	11/1956	Lafitte	
2,978,262	A	4/1961	Franck	
3,038,366	A	6/1962	Hindman	
3,332,708	A	7/1967	Jackson et al.	
3,482,863	A	12/1969	Jackson	
3,596,933	A	8/1971	Luckenbill	
3,738,688	A	6/1973	Racine	
4,489,855	A	12/1984	Boetger	
4,567,814	A	2/1986	Elkridge	
4,672,858	A	6/1987	Langowski	
4,872,102	A *	10/1989	Getter	363/141
D327,050	S *	6/1992	Zirinsky	D13/110
5,199,838	A	4/1993	Luke et al.	
5,215,137	A	6/1993	Weeks et al.	
D349,682	S *	8/1994	Hunziker	D13/110
5,497,289	A *	3/1996	Sugishima et al.	361/709
5,693,025	A	12/1997	Stevens	

5,949,640	A *	9/1999	Cameron et al.	361/600
D427,146	S *	6/2000	Wei	D13/110
D427,148	S *	6/2000	Wei	D13/110
D436,918	S *	1/2001	Matsuda	D13/110
6,411,514	B1 *	6/2002	Hussaini	361/704
6,604,900	B2	8/2003	Ikami et al.	
D483,725	S *	12/2003	Thompson et al.	D13/184
6,702,336	B1	3/2004	Chelchowski et al.	
D495,296	S *	8/2004	Hussaini et al.	D13/110
D496,629	S *	9/2004	Hriscu et al.	D13/110
6,938,437	B2	9/2005	Velez et al.	
6,979,322	B2	12/2005	Chu et al.	
2005/0140141	A1	6/2005	Velez et al.	

* cited by examiner

Primary Examiner—Prabhakar Deshmukh

Assistant Examiner—Derrick Holland

(74) *Attorney, Agent, or Firm*—Wesley W. Muller

(57) **CLAIM**

The ornamental design for an inverter, as shown and described.

DESCRIPTION

FIG. 1 is a front perspective view of an inverter showing my new design;

FIG. 2 is an elevated front view thereof;

FIG. 3 is an elevated rear view thereof;

FIG. 4 is a top plan view thereof;

FIG. 5 is a bottom plan view thereof;

FIG. 6 is left side view thereof; and,

FIG. 7 is a right side view thereof.

The broken lines in the figures merely illustrate the environment for the inverter of the present design and therefore form no part of the claimed design.

1 Claim, 7 Drawing Sheets

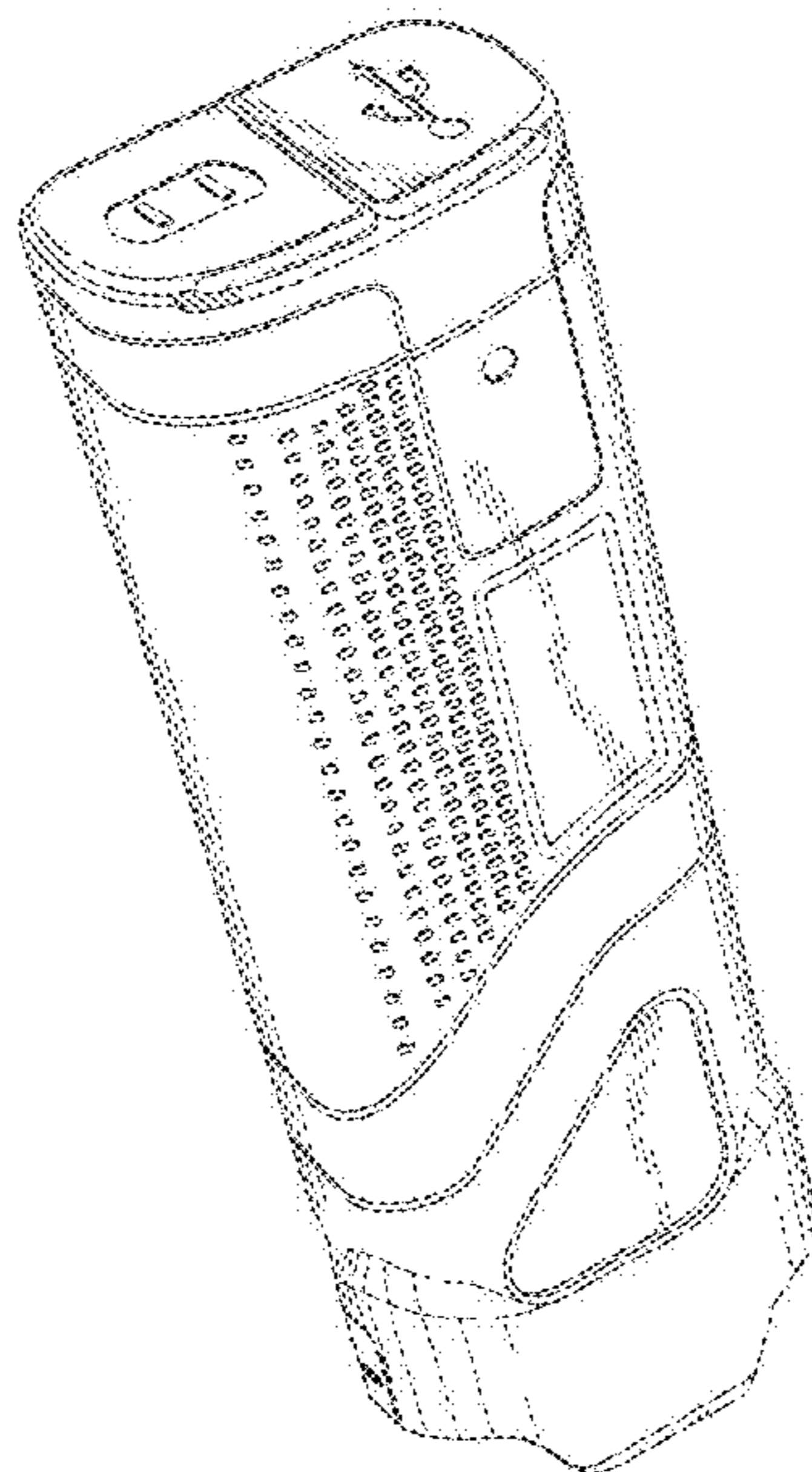

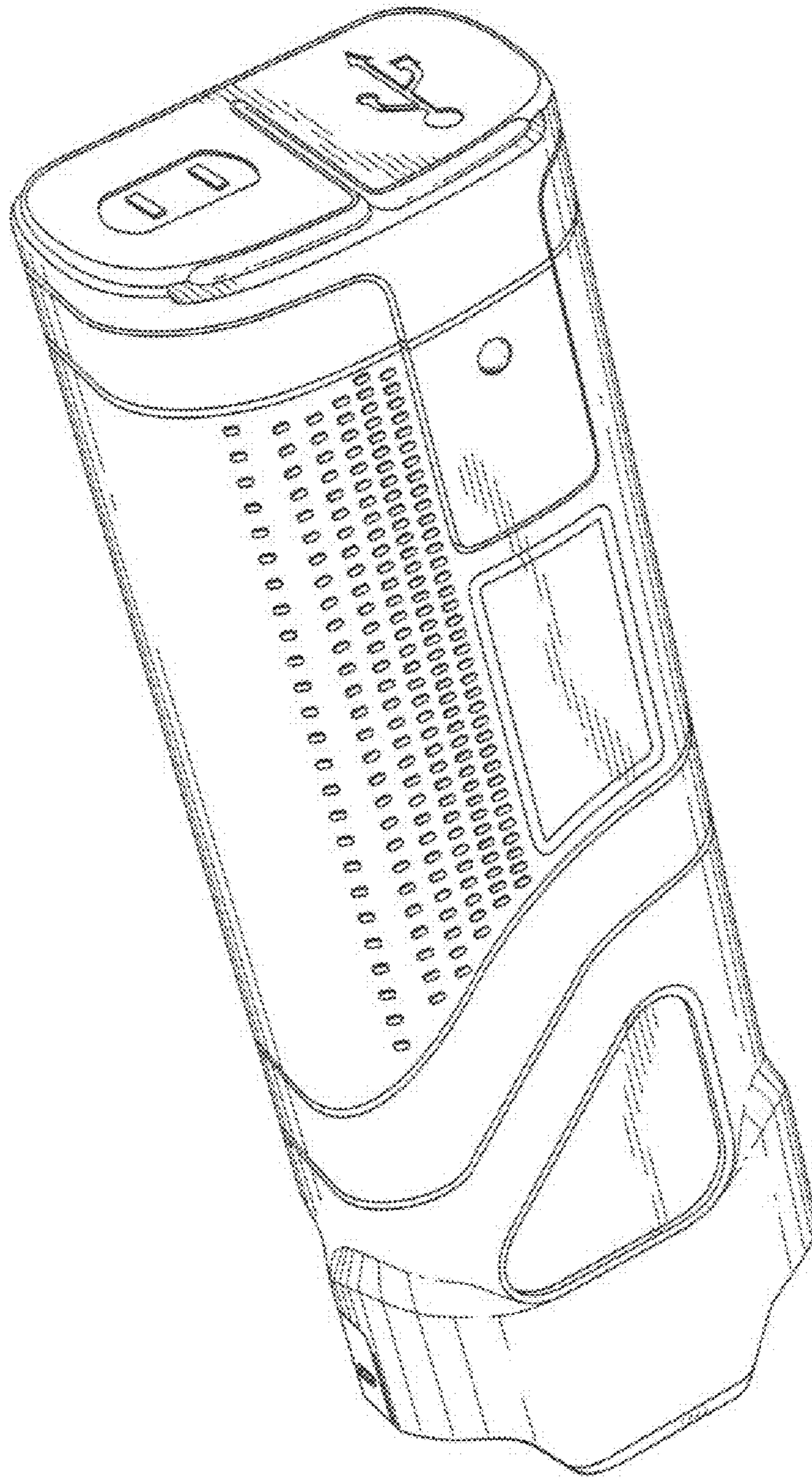

Fig. 1

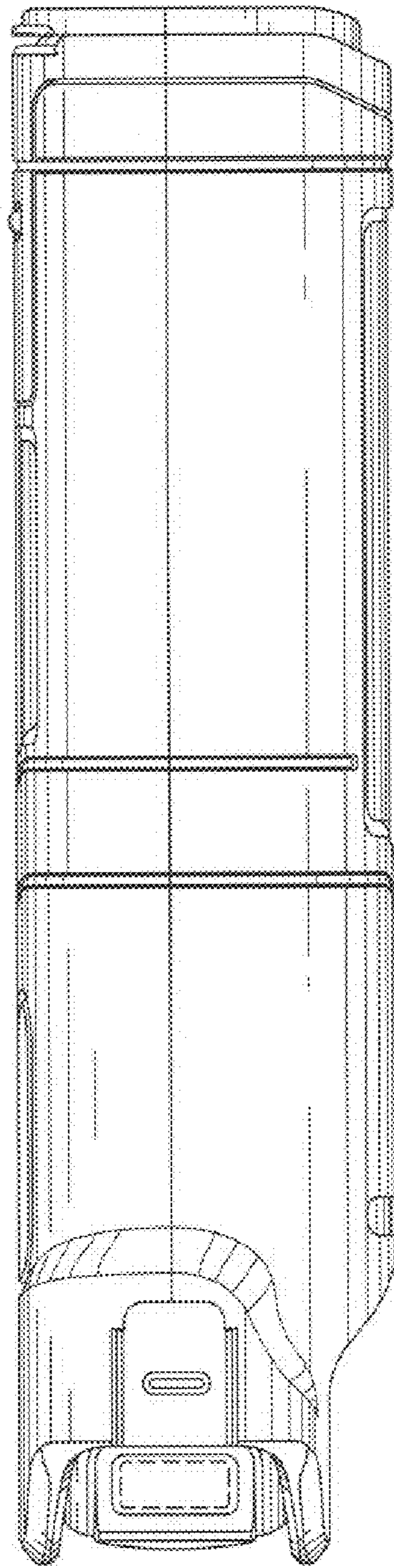

Fig. 2

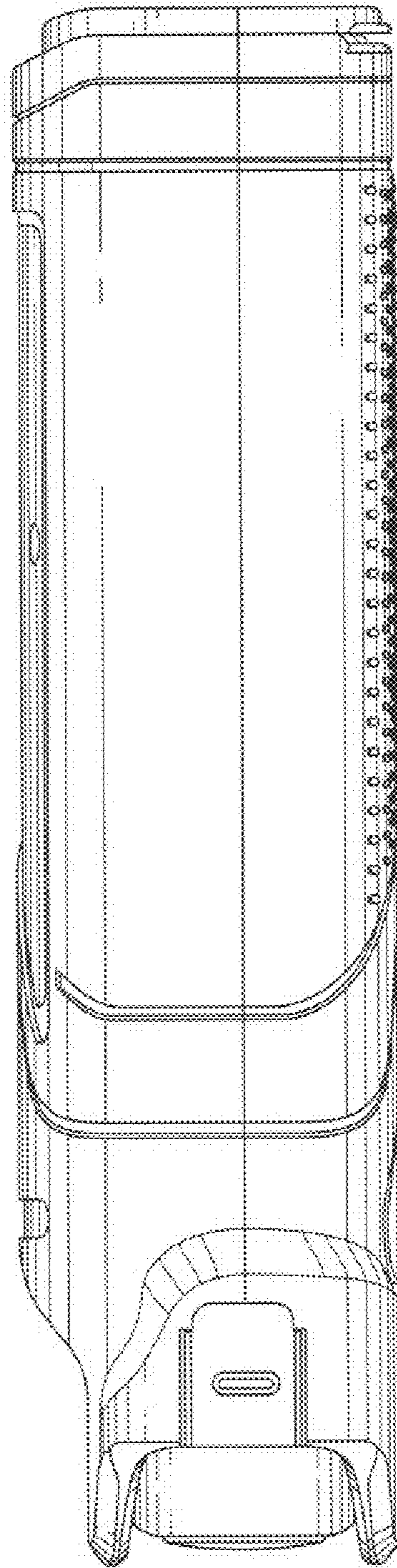

Fig. 3

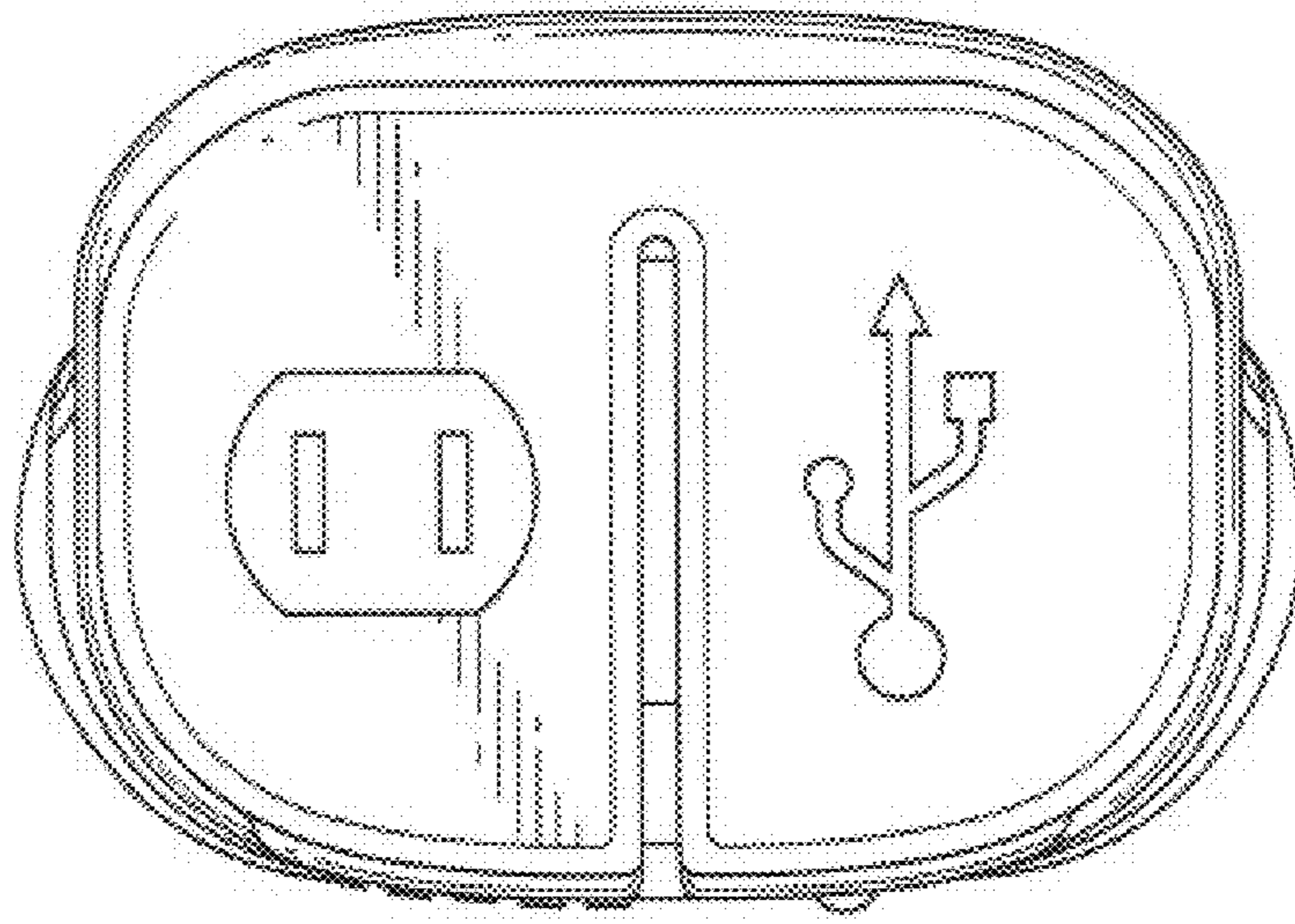

Fig. 4

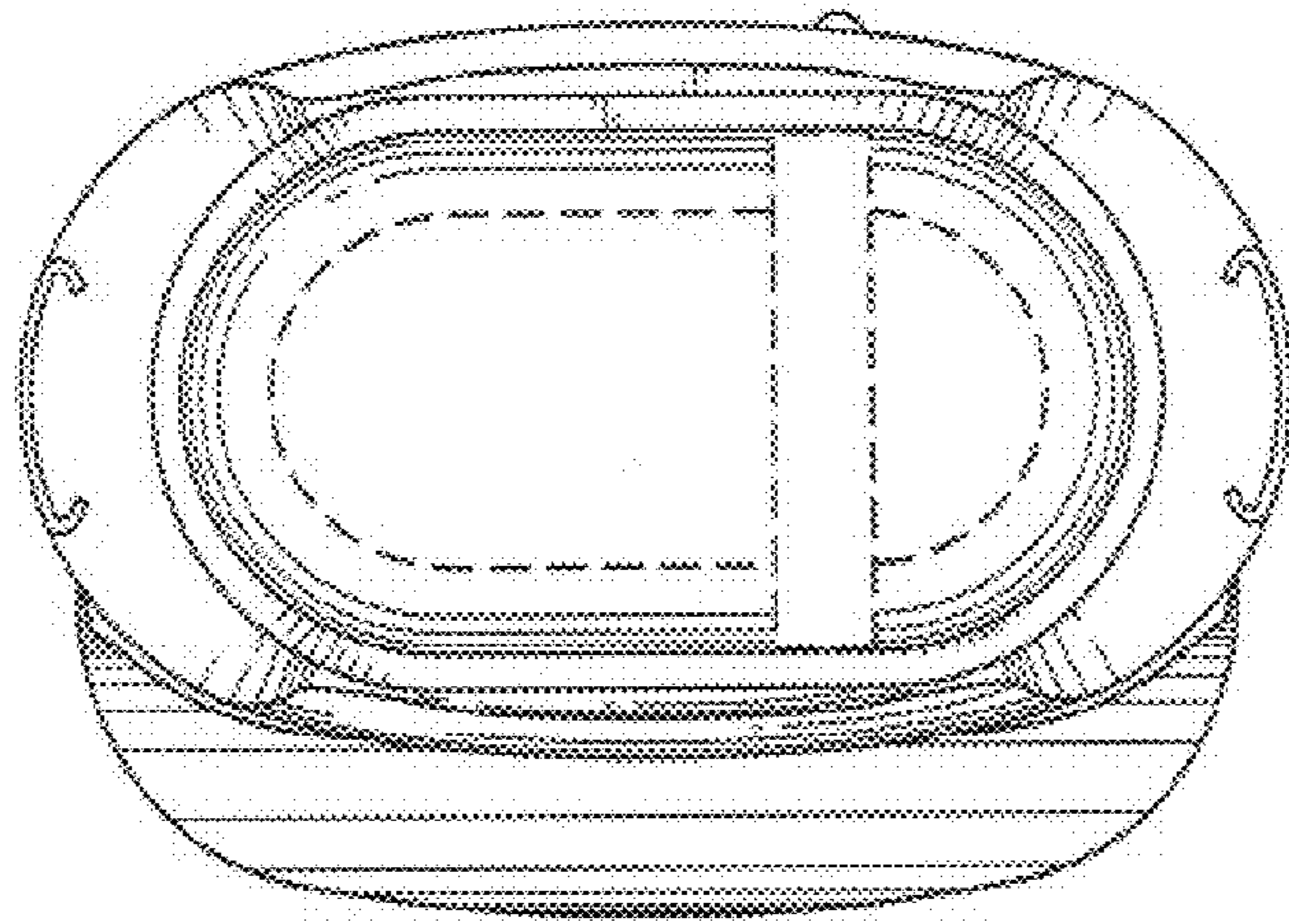

Fig. 5

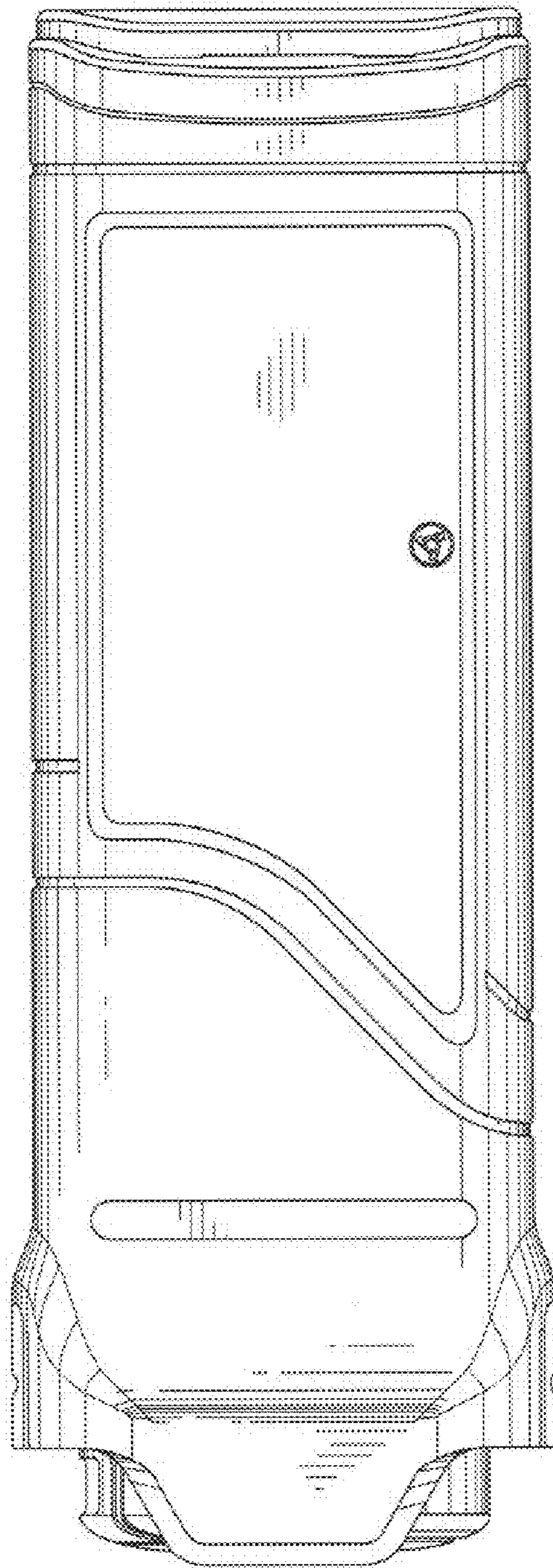

Fig. 6

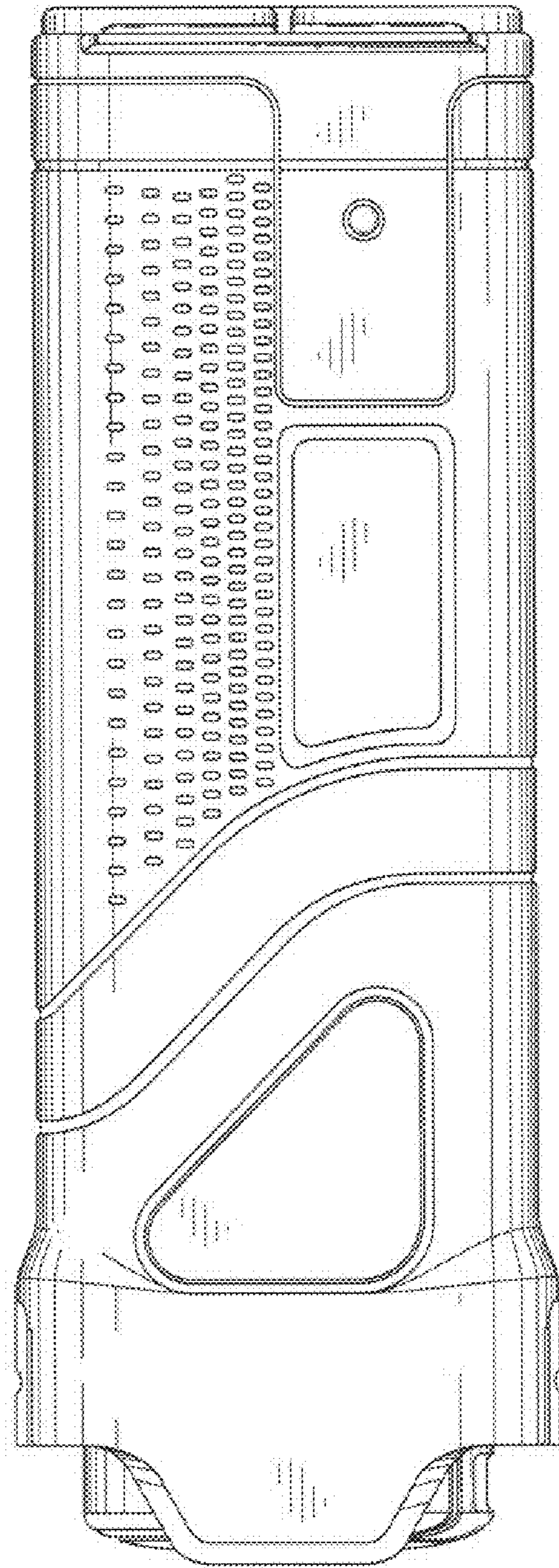

Fig. 7