



US00D582834S

(12) **United States Design Patent**
Daneault et al.

(10) **Patent No.:** **US D582,834 S**
(45) **Date of Patent:** **** Dec. 16, 2008**

(54) **PASSENGER DORSAL SUPPORT**

(75) Inventors: **Louis-Philippe Daneault**, Montreal (CA); **Marc-André Boudreau**, Montreal (CA); **Steve Beaulieu**, Prevost (CA)

(73) Assignee: **Novabus, Division De Groupe Volvo Canada Inc.**, Sainte-Eustache (CA)

(**) Term: **14 Years**

(21) Appl. No.: **29/298,501**

(22) Filed: **Dec. 6, 2007**

(51) **LOC (8) Cl.** **12-16**

(52) **U.S. Cl.** **D12/400; D6/356**

(58) **Field of Classification Search** D6/334,
D6/335, 358, 364, 365, 366, 367, 374, 379,
D6/380, 381, 500-502, 356; 297/181, 284.4,
297/353, 452.29, 425.3, 463.1; D12/1, 42,
D12/322, 400, 12, 13, 14, 15, 36, 40, 52;
296/179, 178

See application file for complete search history.

(56) **References Cited**

U.S. PATENT DOCUMENTS

- D244,731 S * 6/1977 James et al. D6/356
- D284,144 S * 6/1986 Pedersen D6/374
- D565,872 S * 4/2008 Huang D6/502

* cited by examiner

Primary Examiner—Robert M. Spear

Assistant Examiner—Ania K Dworzecka

(74) *Attorney, Agent, or Firm*—Ogilvy Renault LLP

(57) **CLAIM**

The ornamental design for a passenger dorsal support, as shown and described.

DESCRIPTION

FIG. 1 is a front perspective view of a passenger dorsal support in accordance with a first variant of our new design; FIG. 2 is a front elevation view of the passenger dorsal support of FIG. 1;

FIG. 3 is a rear elevation view of the passenger dorsal support of FIG. 1;

FIG. 4 is a left side elevation view of the passenger dorsal support of FIG. 1, the opposite right side being a mirror image thereof;

FIG. 5 is a top plan view of the passenger dorsal support of FIG. 1;

FIG. 6 is a bottom plan view of the passenger dorsal support of FIG. 1;

FIG. 7 is a front perspective view of a passenger dorsal support in accordance with a second variant of our new design;

FIG. 8 is a front elevation view of the passenger dorsal support of FIG. 7;

FIG. 9 is a rear elevation view of the passenger dorsal support of FIG. 7;

FIG. 10 is a left side elevation view of the passenger dorsal support of FIG. 7, the opposite right side being a mirror image thereof;

FIG. 11 is a top plan view of the passenger dorsal support of FIG. 7; and,

FIG. 12 is a bottom plan view of the passenger dorsal support of FIG. 7.

Any parts shown in broken lines form no part of the claimed design.

1 Claim, 10 Drawing Sheets

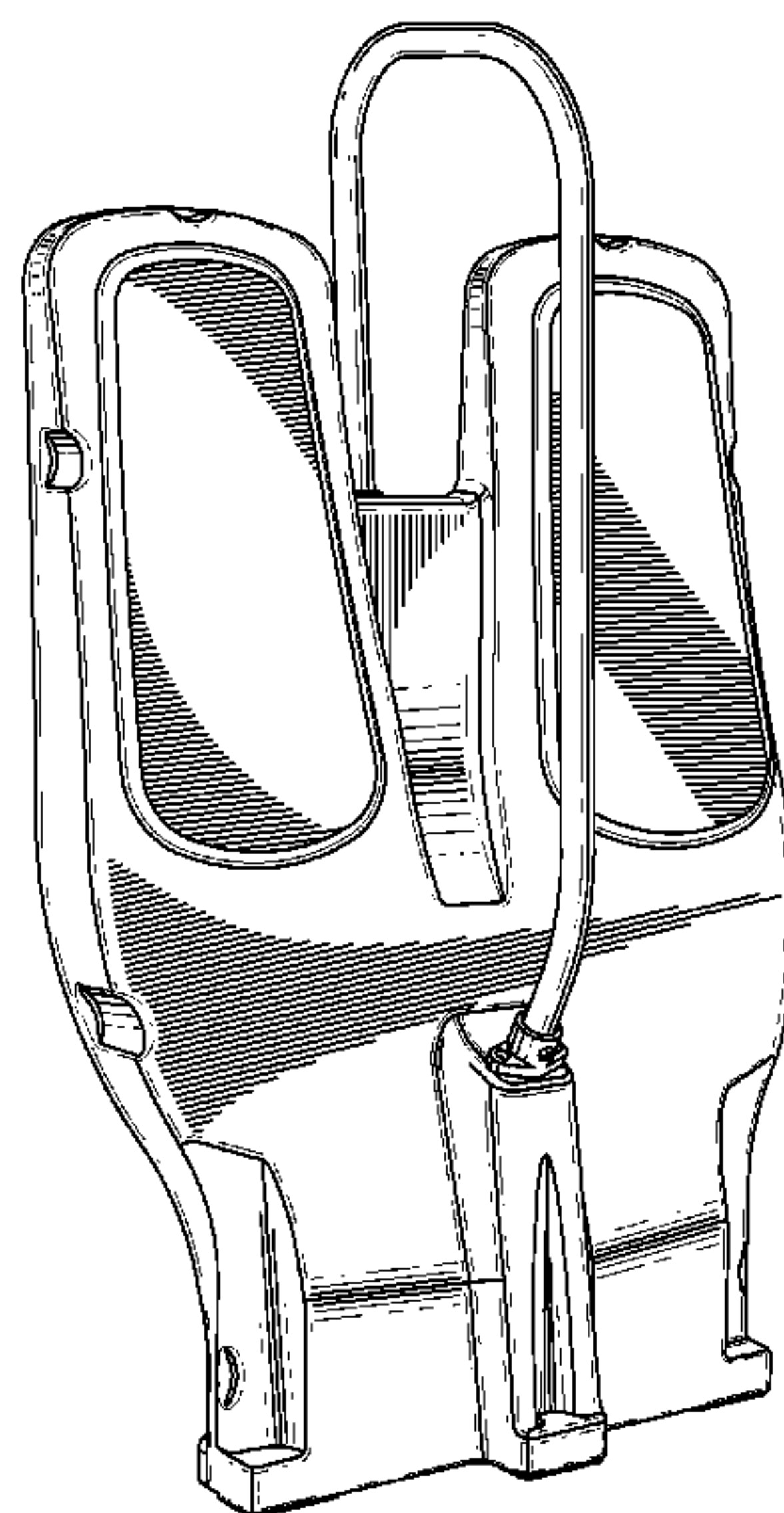

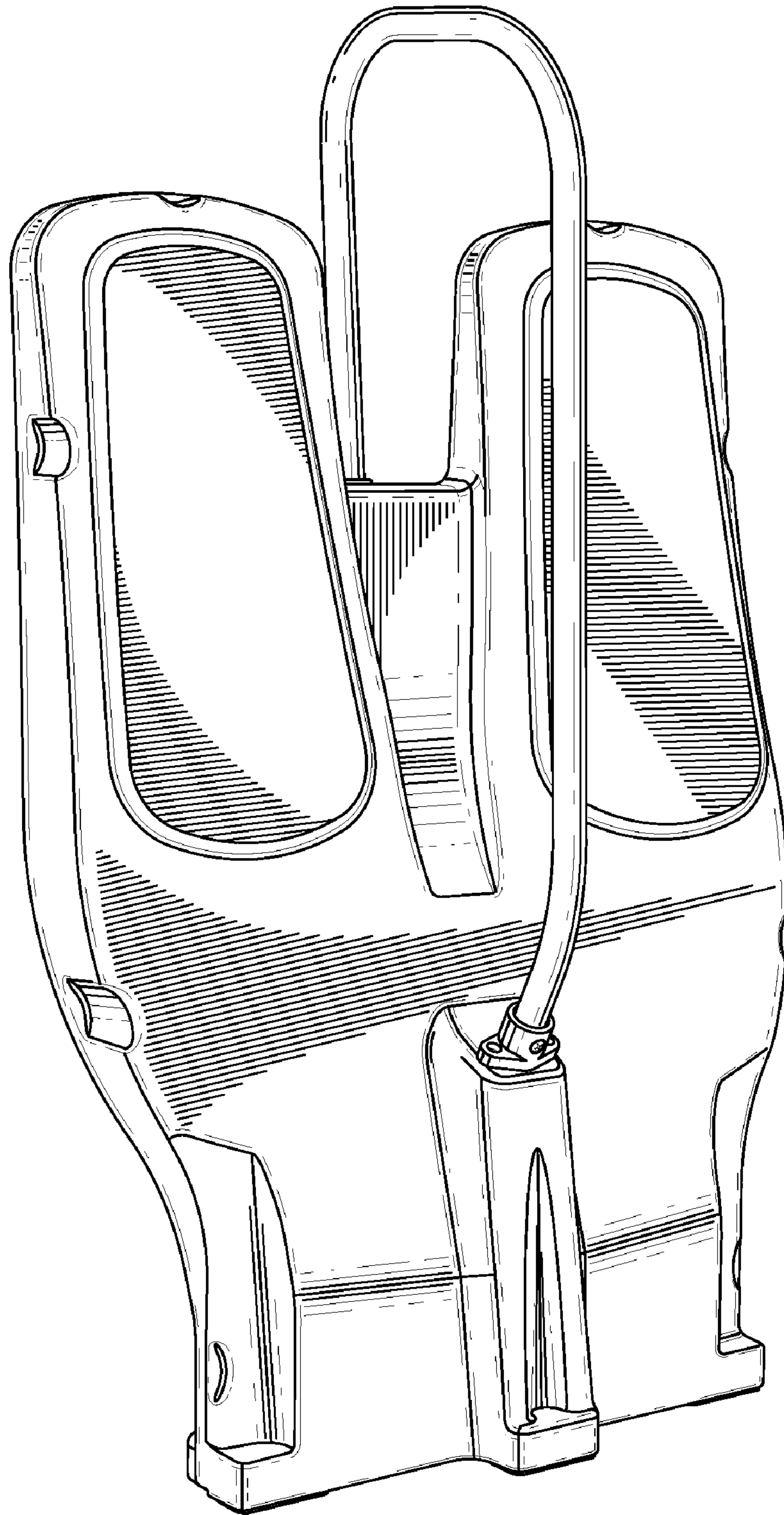

FIG. 1

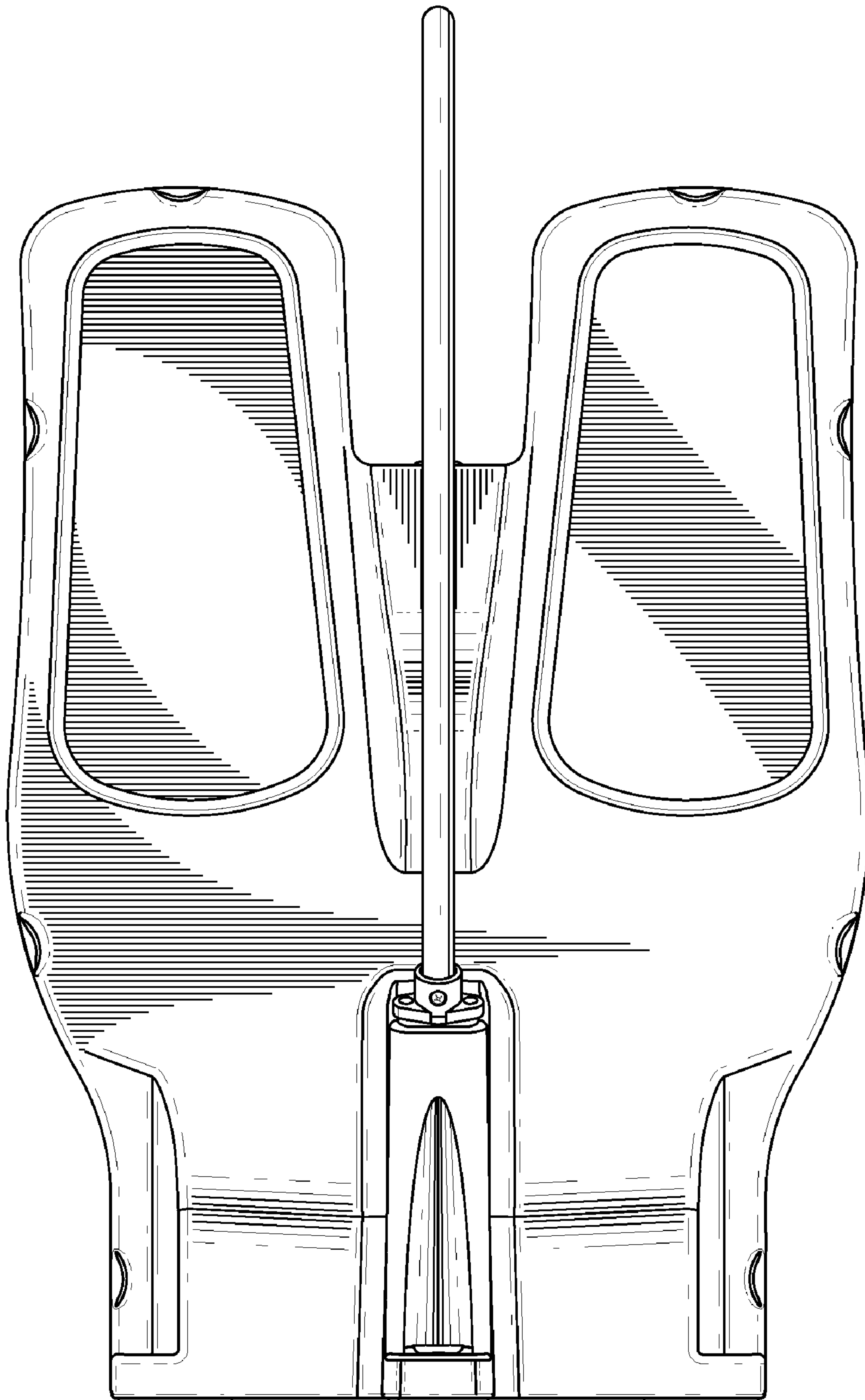

FIG. 2

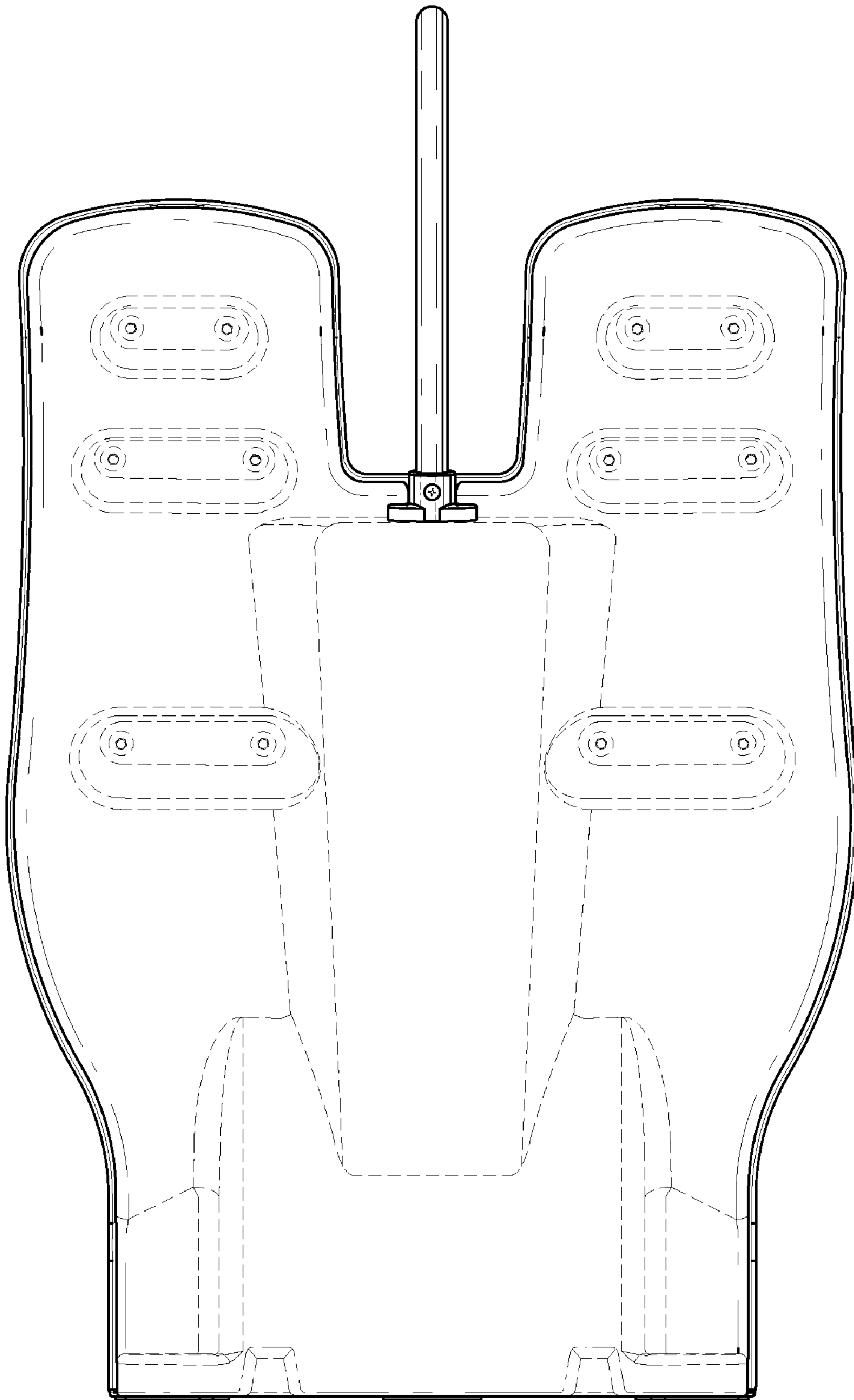

FIG. 3

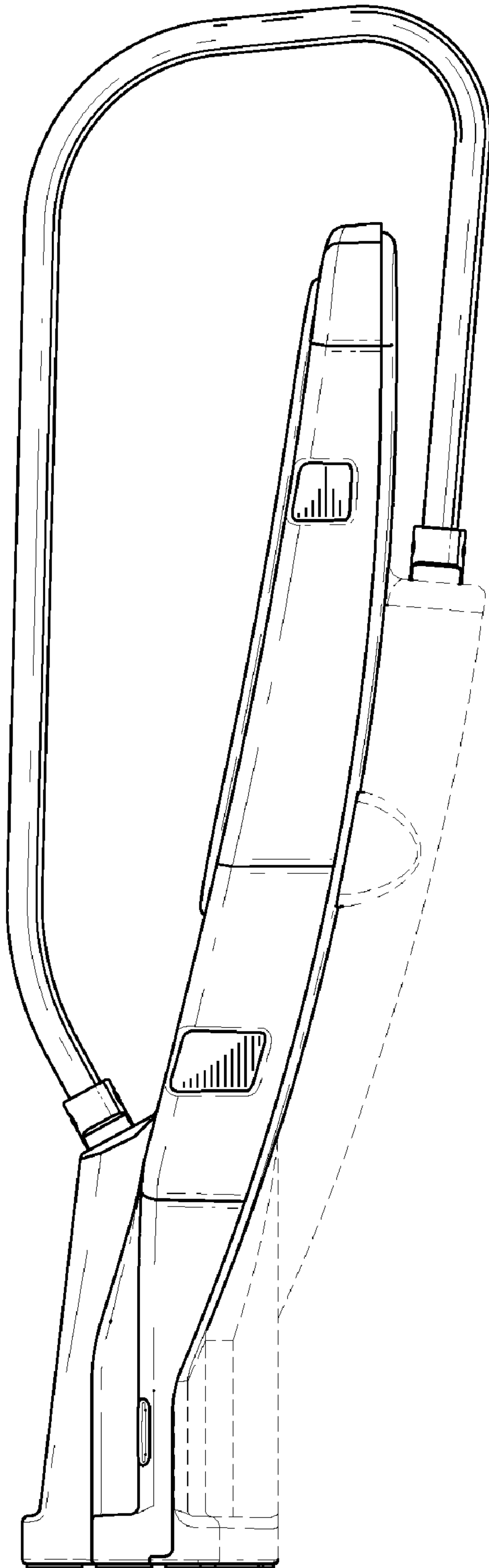

FIG. 4

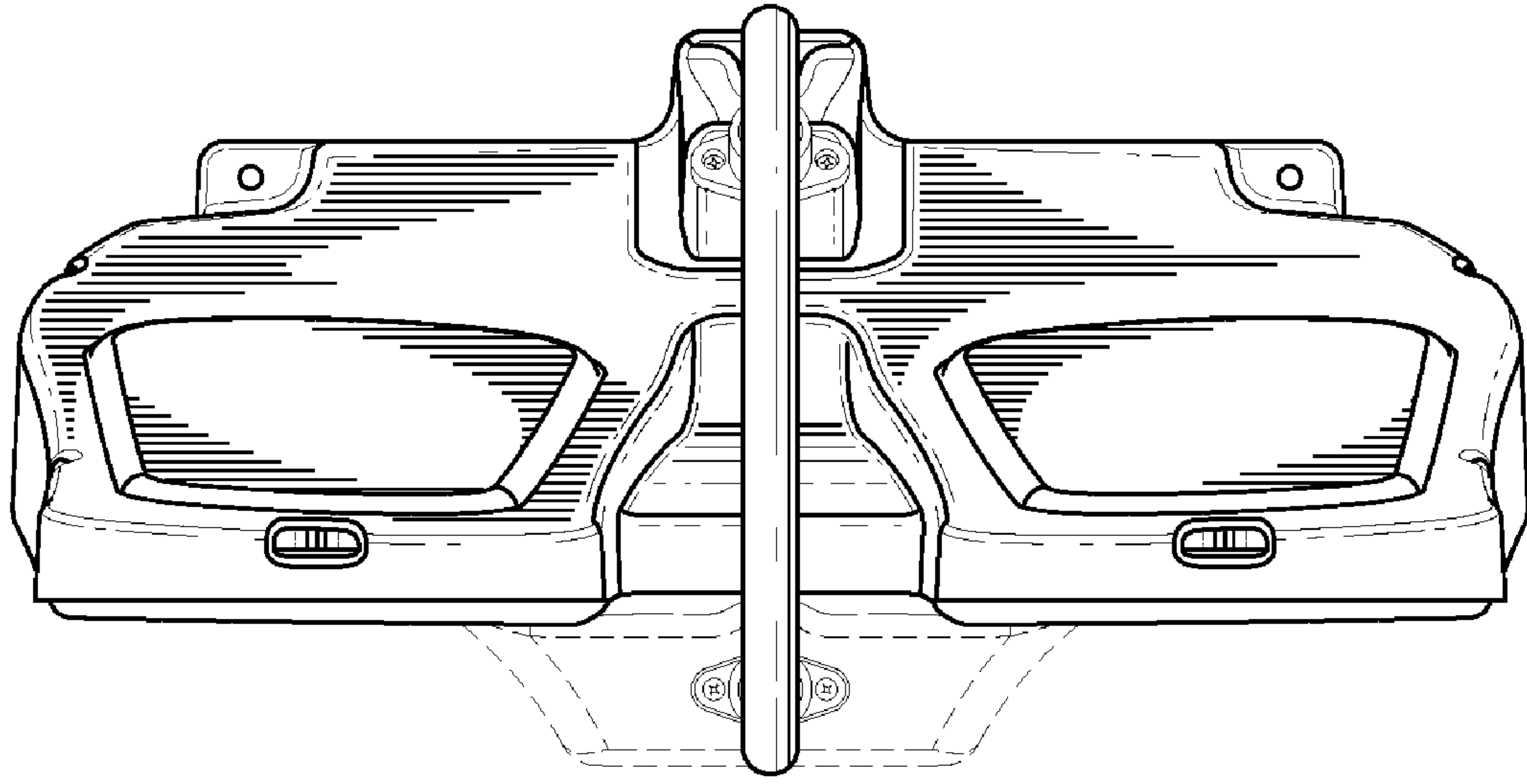

FIG. 5

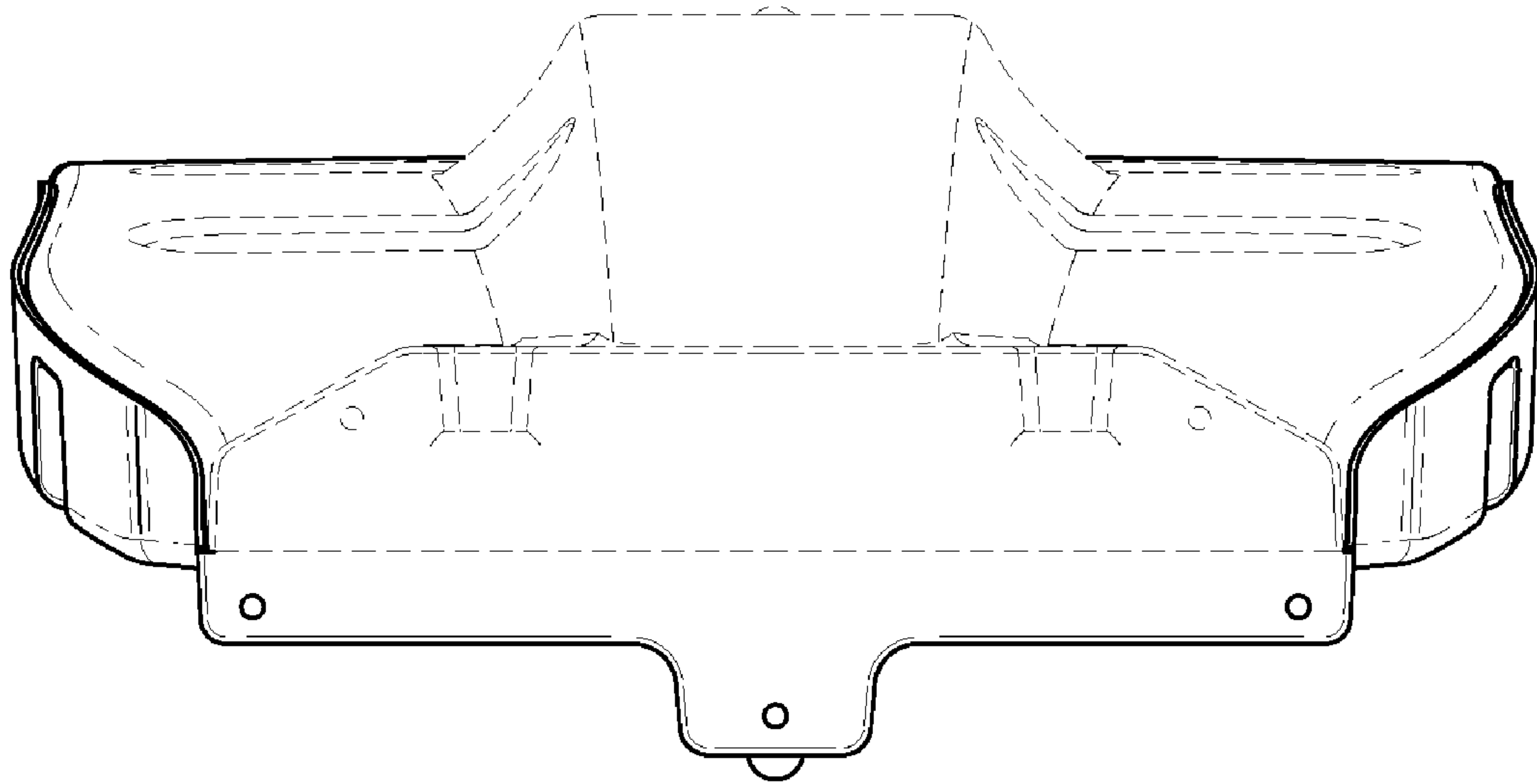

FIG. 6

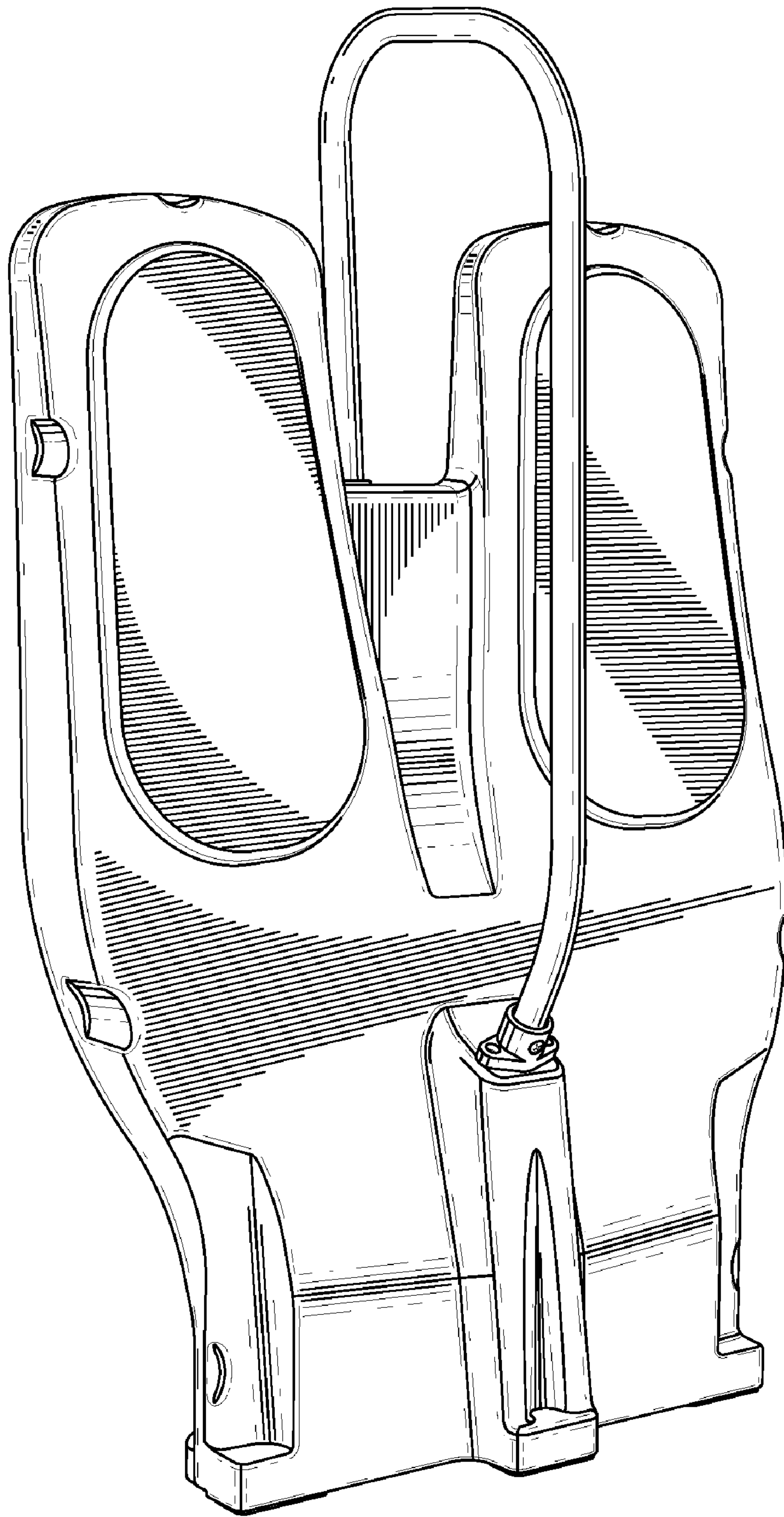

FIG. 7

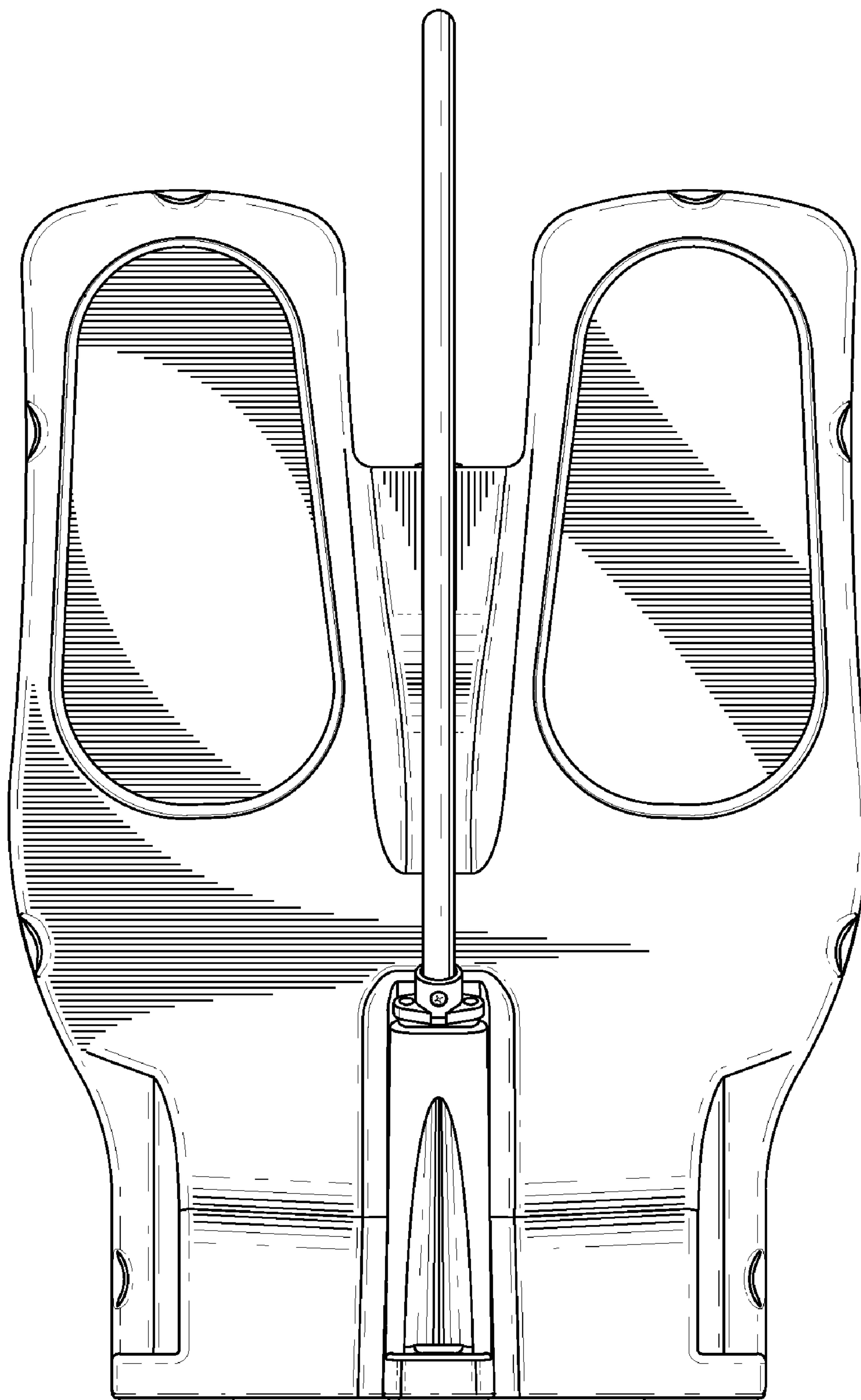

FIG. 8

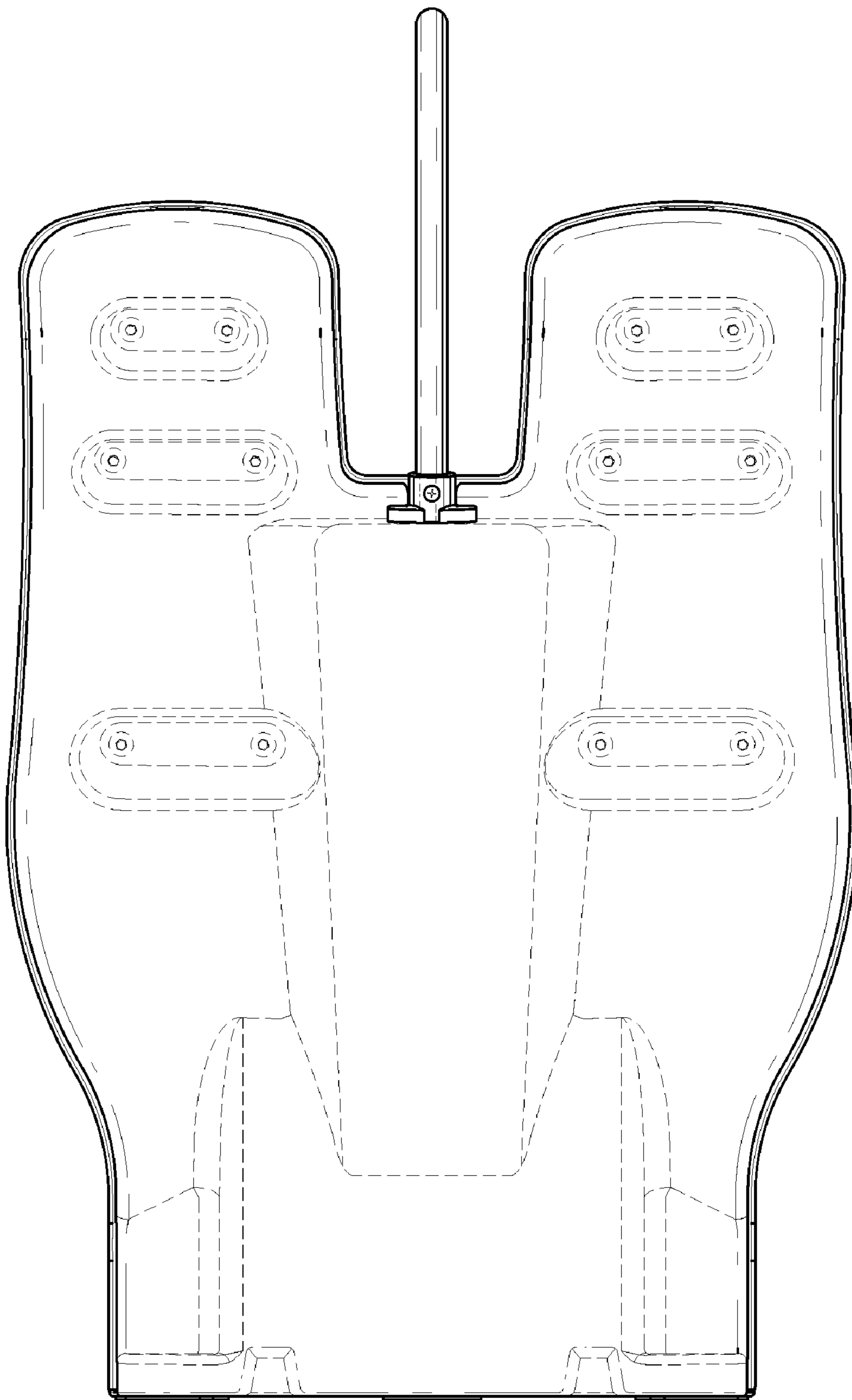

FIG. 9

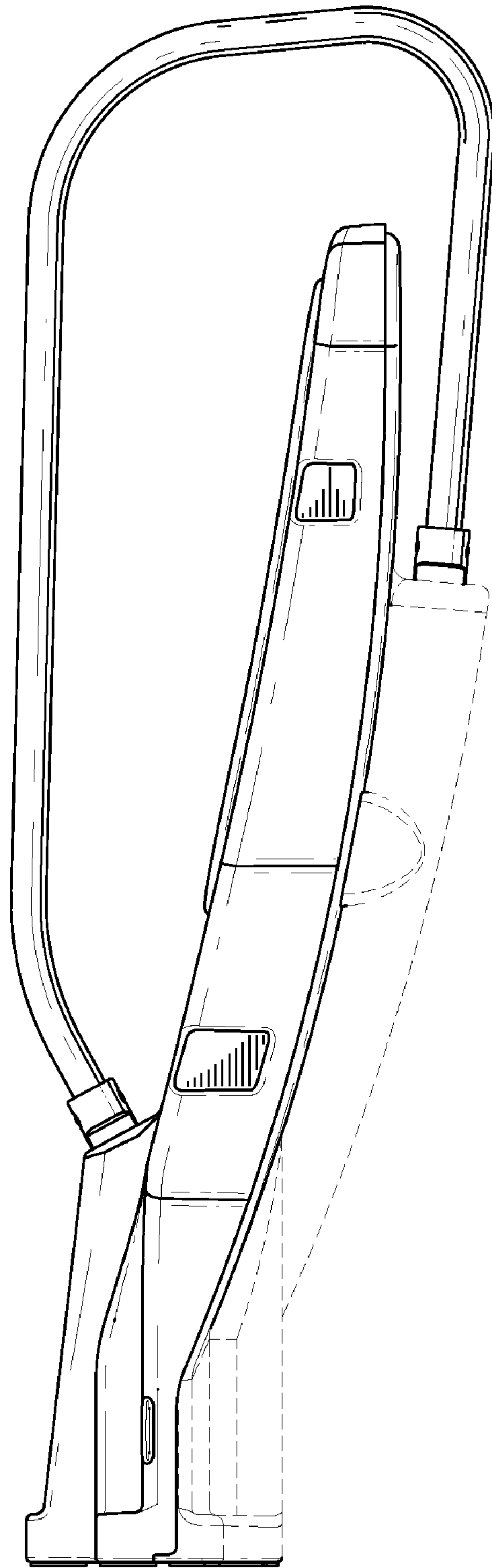

FIG. 10

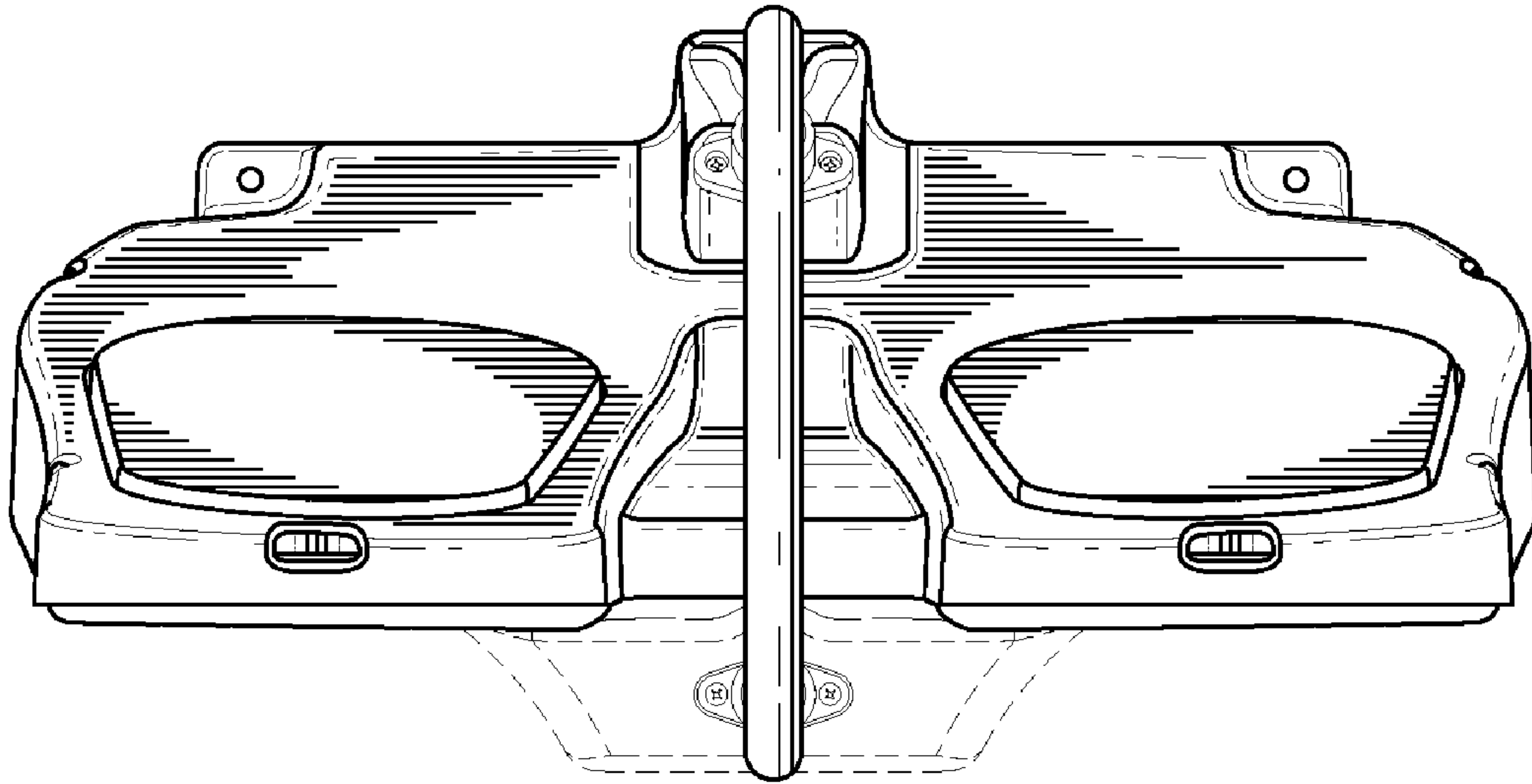

FIG. 11

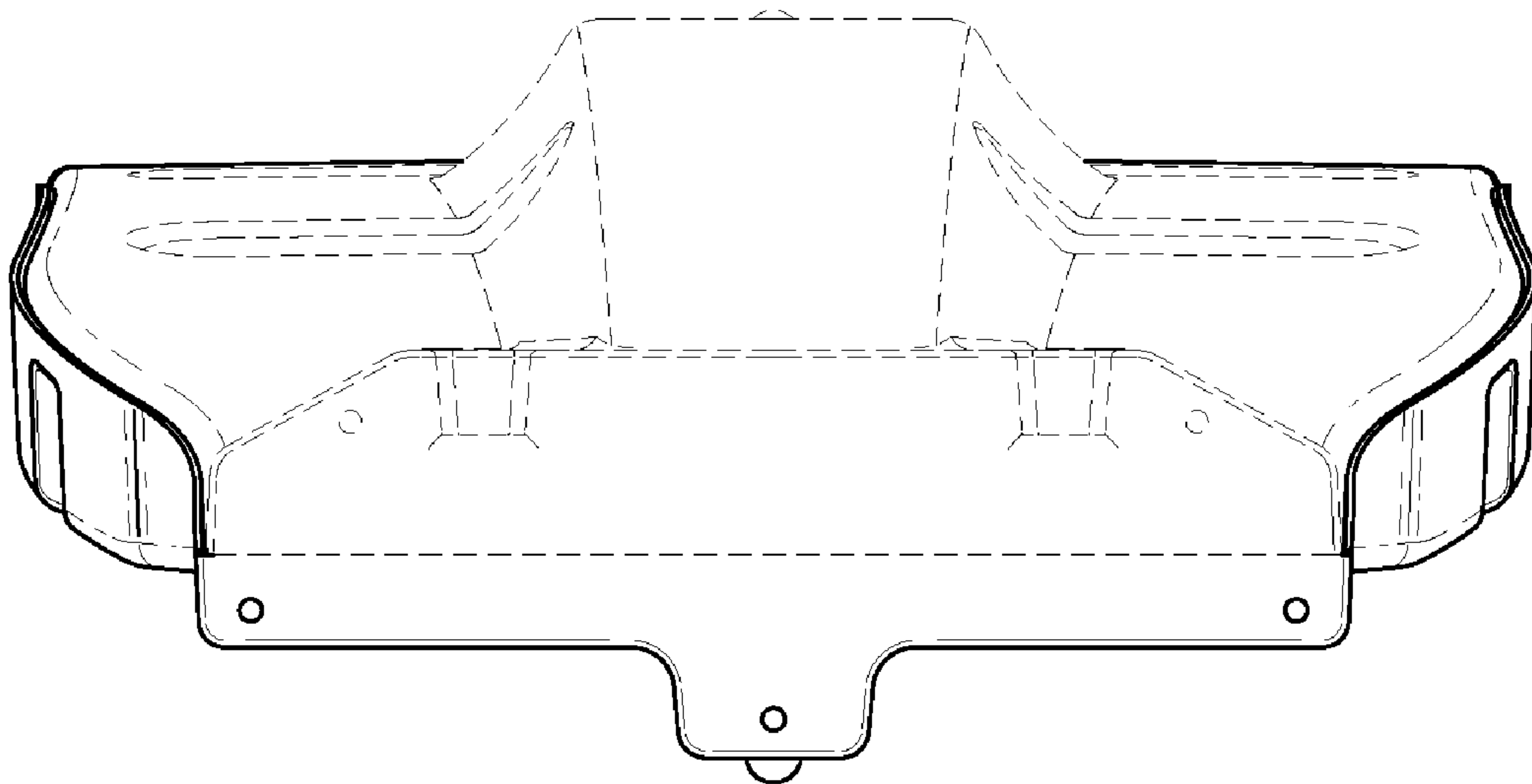

FIG. 12