



US00D582832S

(12) **United States Design Patent**
Dornier

(10) **Patent No.:** **US D582,832 S**

(45) **Date of Patent:** **** Dec. 16, 2008**

(54) **AIRPLANE**

D508,094 S * 8/2005 Khasminsky D21/450

(75) Inventor: **Iren Dornier**, Friedrichshafen (DE)

* cited by examiner

(73) Assignee: **Iren Dornier Consultancy & Services e.K.**, Friedrichshafen (DE)

Primary Examiner—Ian Simmons

Assistant Examiner—Maurice Stevens

(74) *Attorney, Agent, or Firm*—Patzik, Frank & Samotny Ltd.

(**) Term: **14 Years**

(21) Appl. No.: **29/295,896**

(22) Filed: **Oct. 10, 2007**

(57) **CLAIM**

The ornamental design for an airplane, as shown and described.

(30) **Foreign Application Priority Data**

Jul. 18, 2007 (EM) 000760038

DESCRIPTION

(51) **LOC (8) Cl.** **12-07**

(52) **U.S. Cl.** **D12/337**

(58) **Field of Classification Search** D12/319–345;
244/29, 45 R, 55, 15, 91, 13, 87, 12.3

See application file for complete search history.

FIG. 1 is a top plan view showing the new ornamental design;

FIG. 2 is a perspective view, the portions shown in broken lines forming no part of the design sought to be patented;

FIG. 3 is a front elevation view, the portions shown in broken lines forming no part of the design sought to be patented;

FIG. 4 is a side elevation view, the left and right views being a mirror image, the portions shown in broken lines forming no part of the design sought to be patented;

FIG. 5 is a rear elevation view, the portions shown in broken lines forming no part of the design sought to be patented;

FIG. 6 is a side perspective view, the portions shown in broken lines forming no part of the design sought to be patented; and,

FIG. 7 is a bottom plan view thereof, the portions shown in broken lines forming no part of the design sought to be patented.

(56) **References Cited**

U.S. PATENT DOCUMENTS

D233,426 S *	10/1974	Jensen et al.	D12/319
4,027,835 A *	6/1977	Sachs	244/101
D246,168 S *	10/1977	Landrus	D12/332
D264,454 S *	5/1982	Snyder	D12/341
D271,294 S *	11/1983	Hauk	D12/344
D298,026 S *	10/1988	Judge	D12/343
D415,993 S *	11/1999	Birrenbach	D12/337
D421,955 S *	3/2000	Birrenbach	D12/337
D466,858 S *	12/2002	Carroll et al.	D12/337

1 Claim, 7 Drawing Sheets

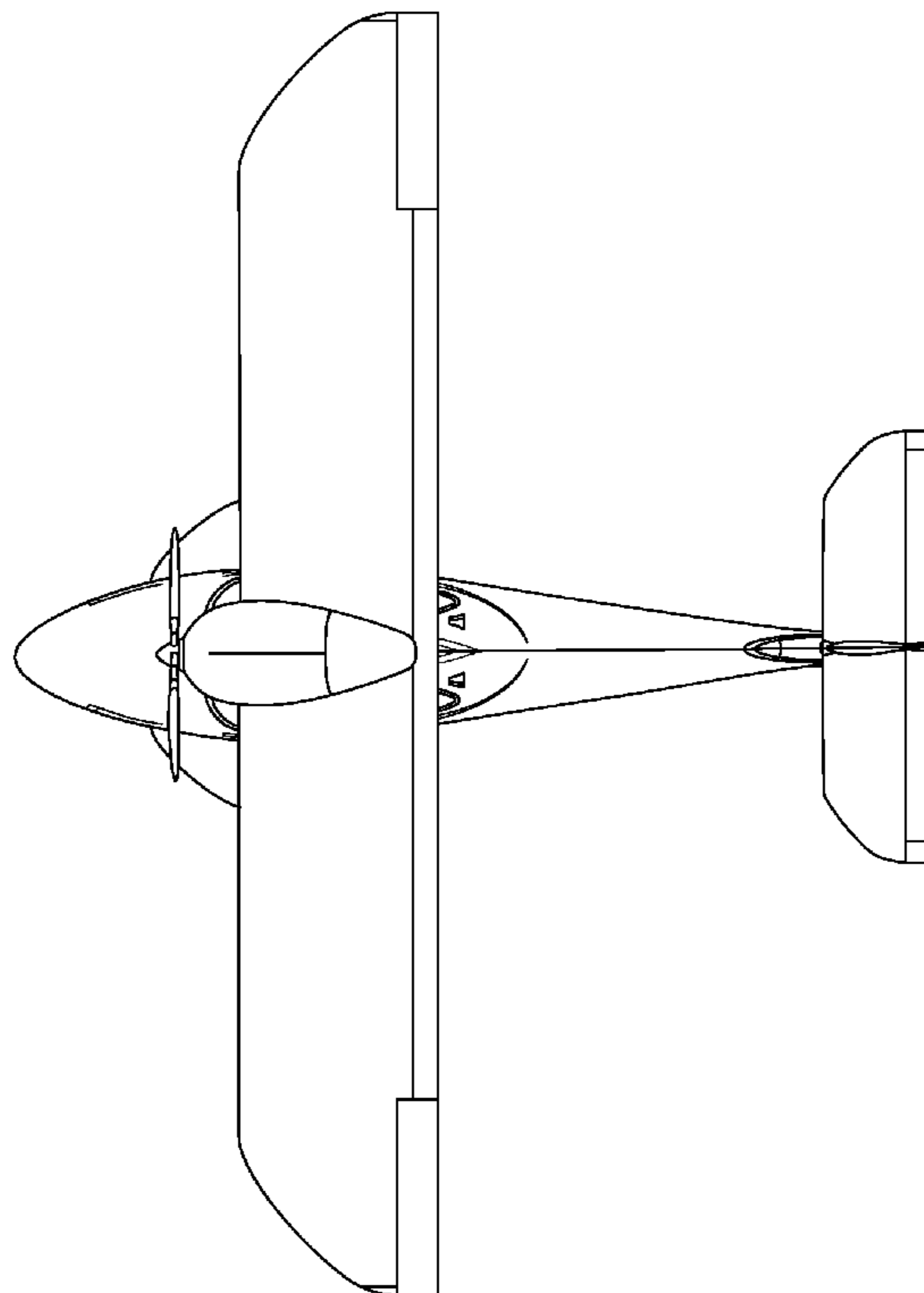

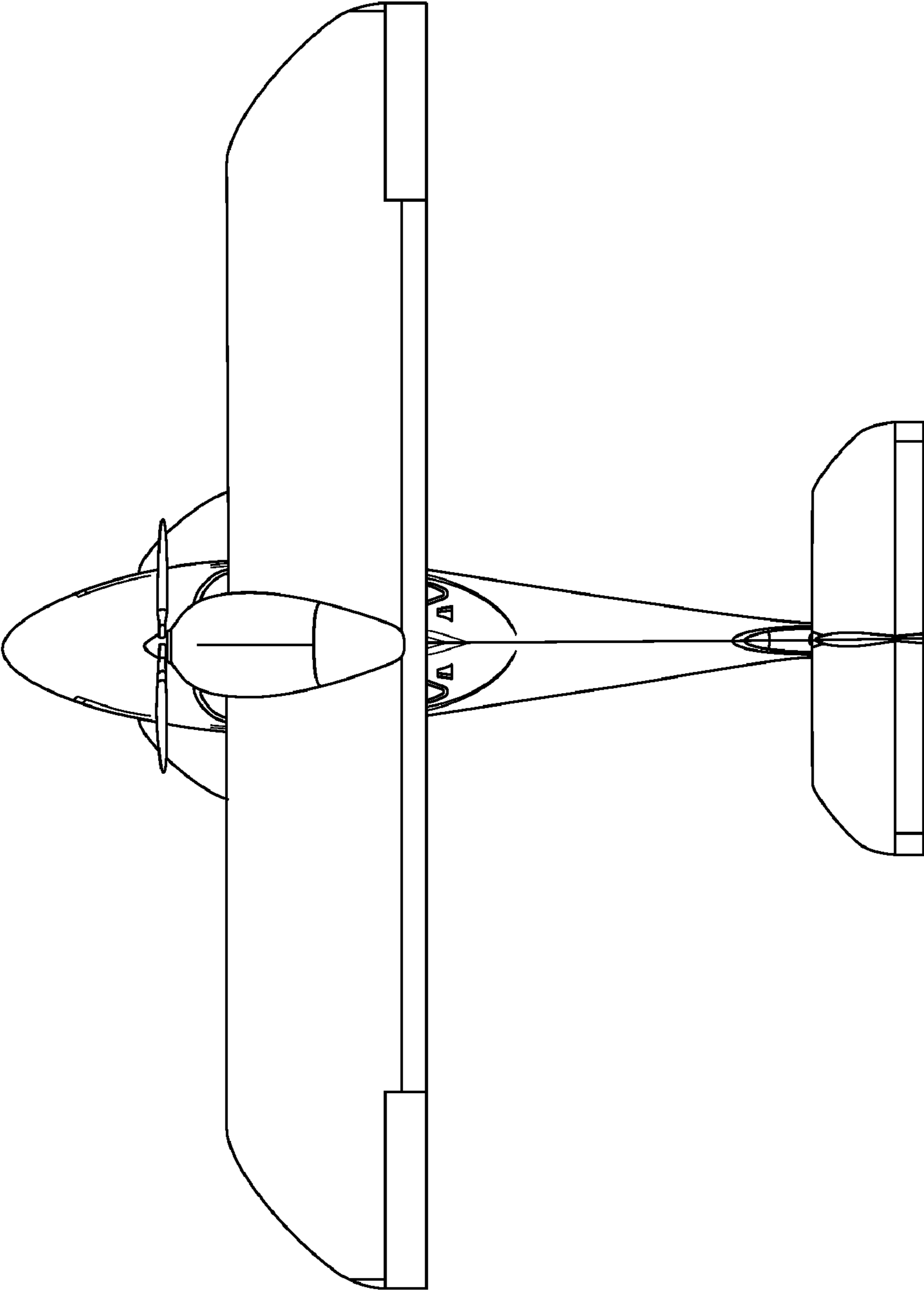

FIG. 1

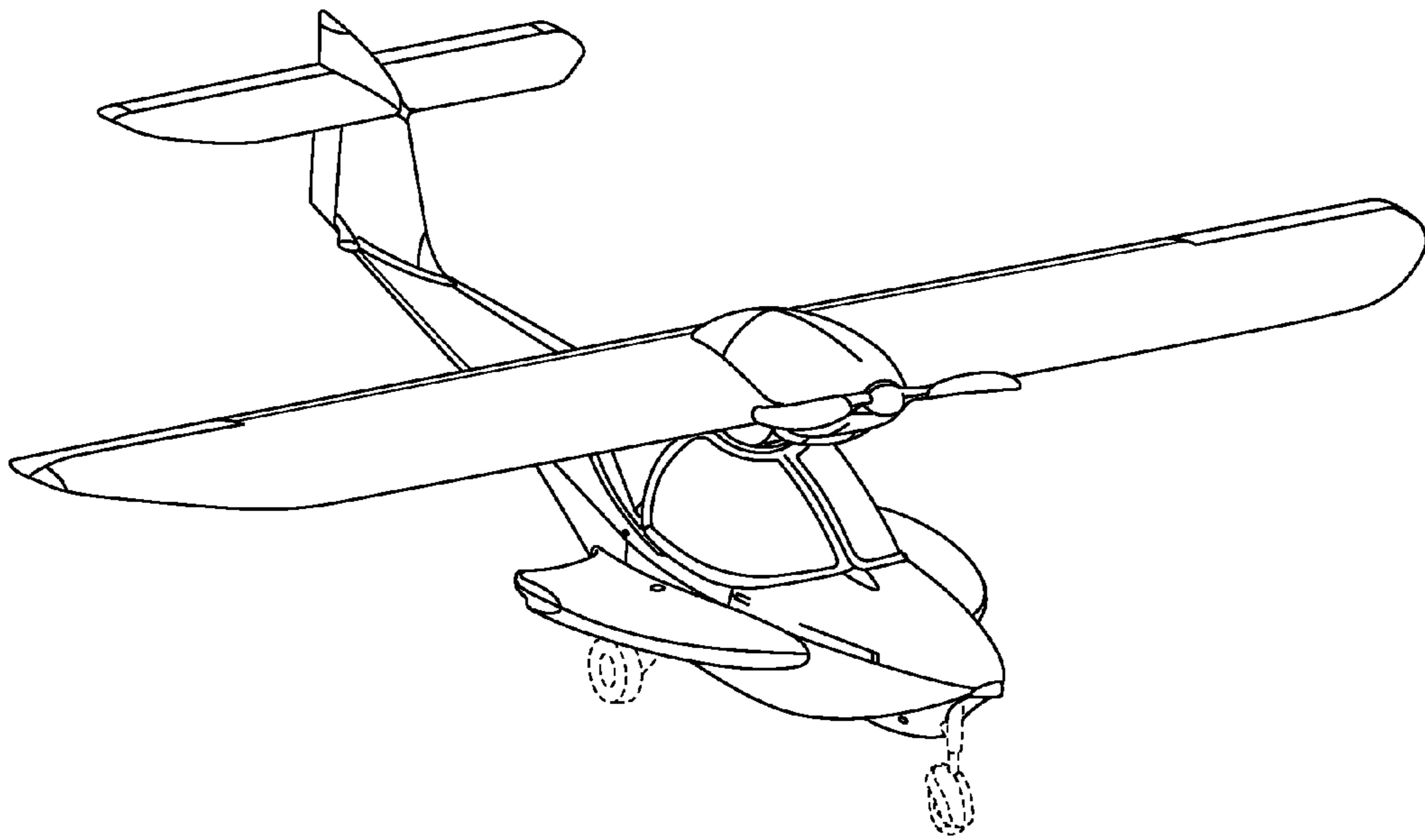

FIG. 2

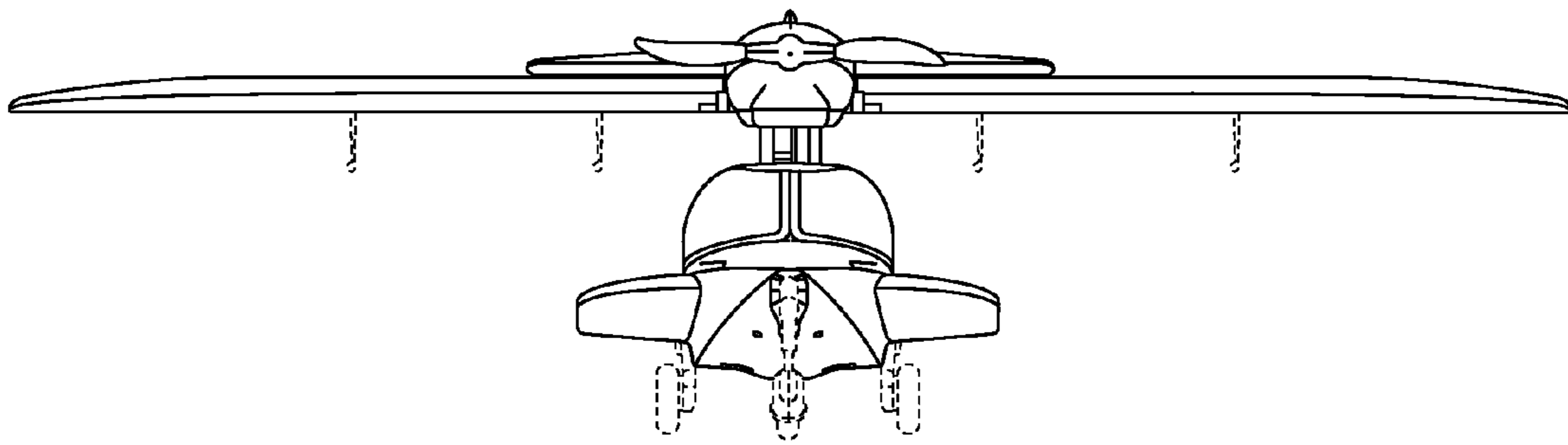

FIG. 3

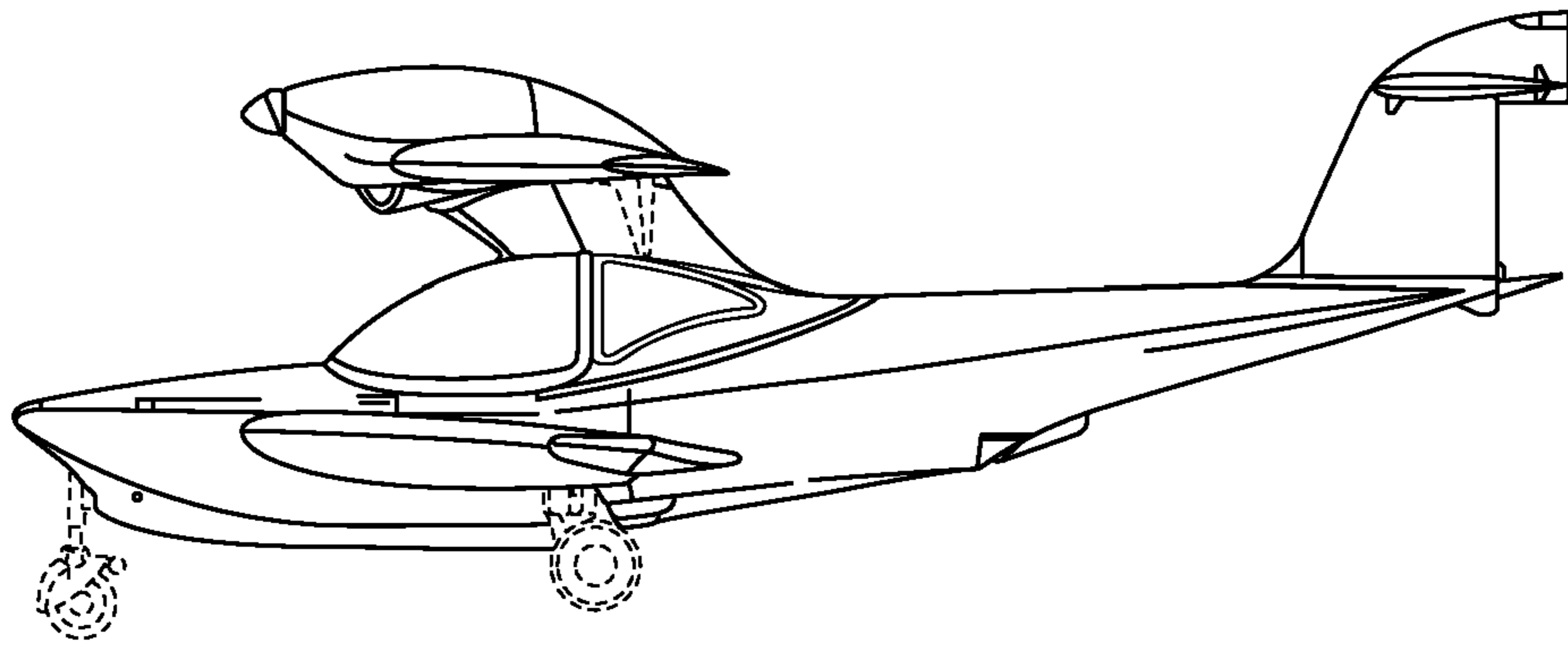

FIG. 4

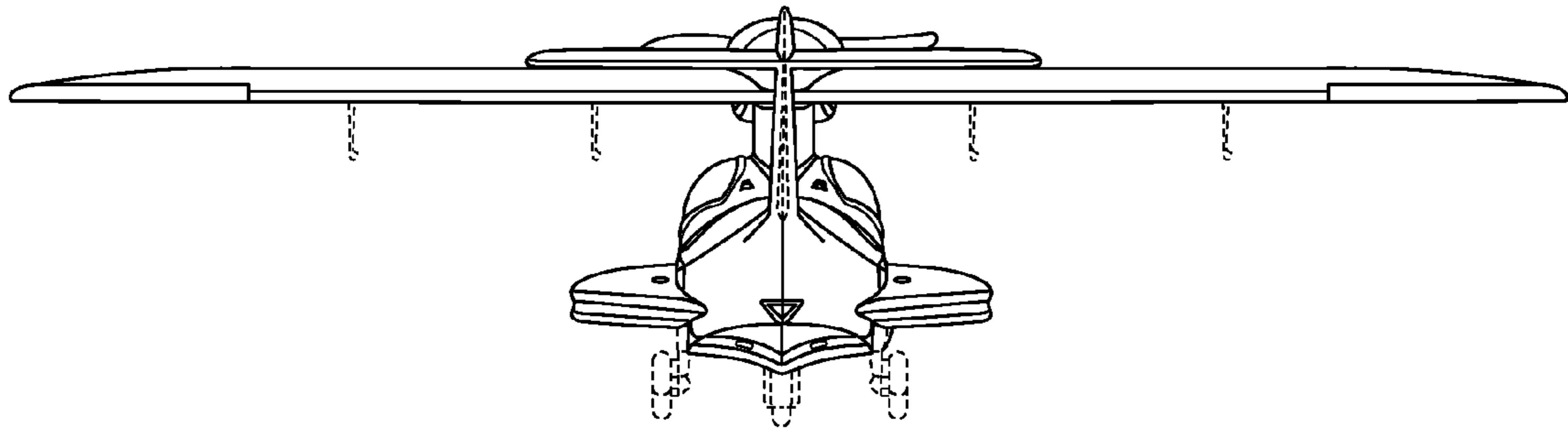

FIG. 5

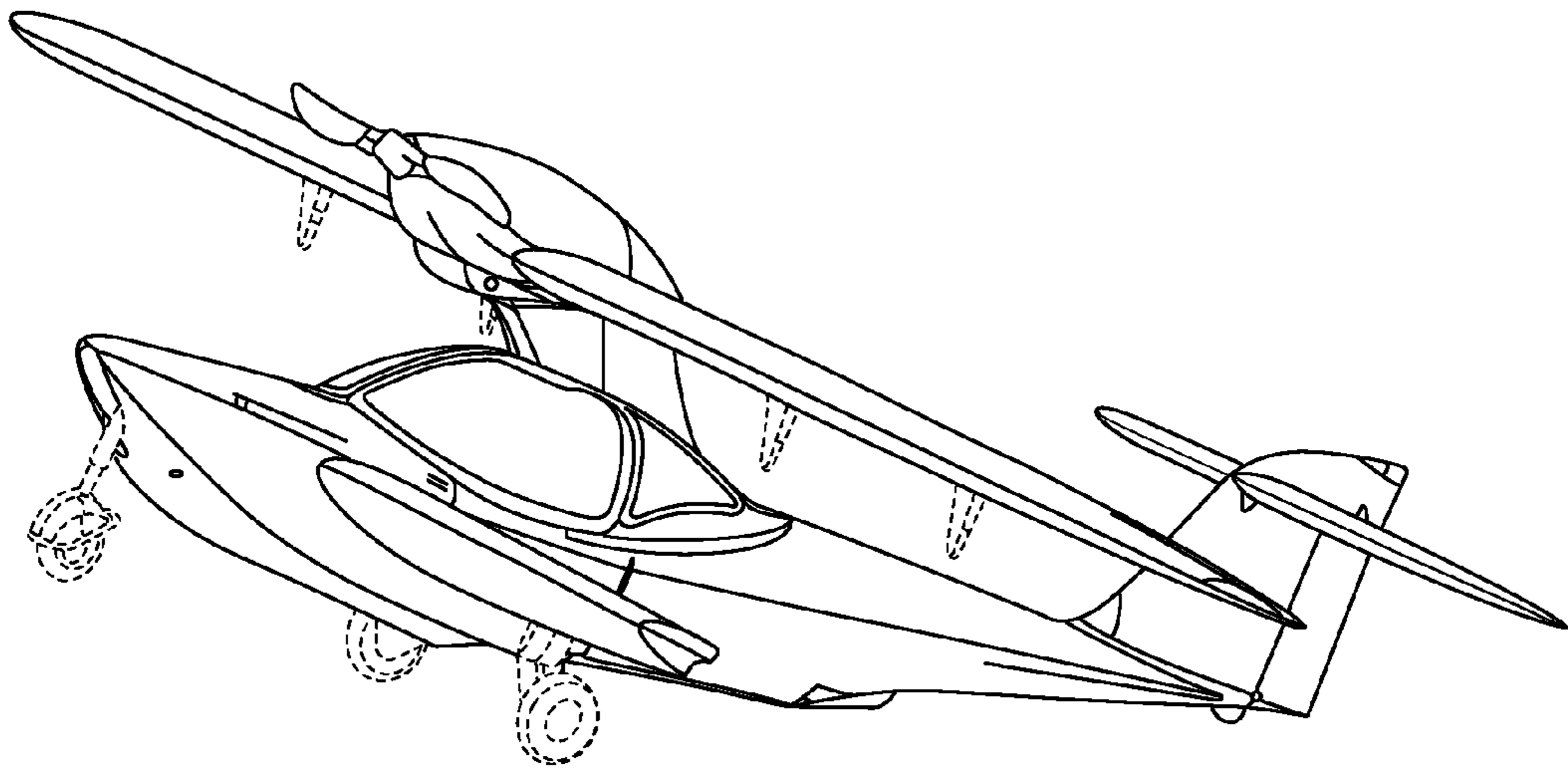

FIG. 6

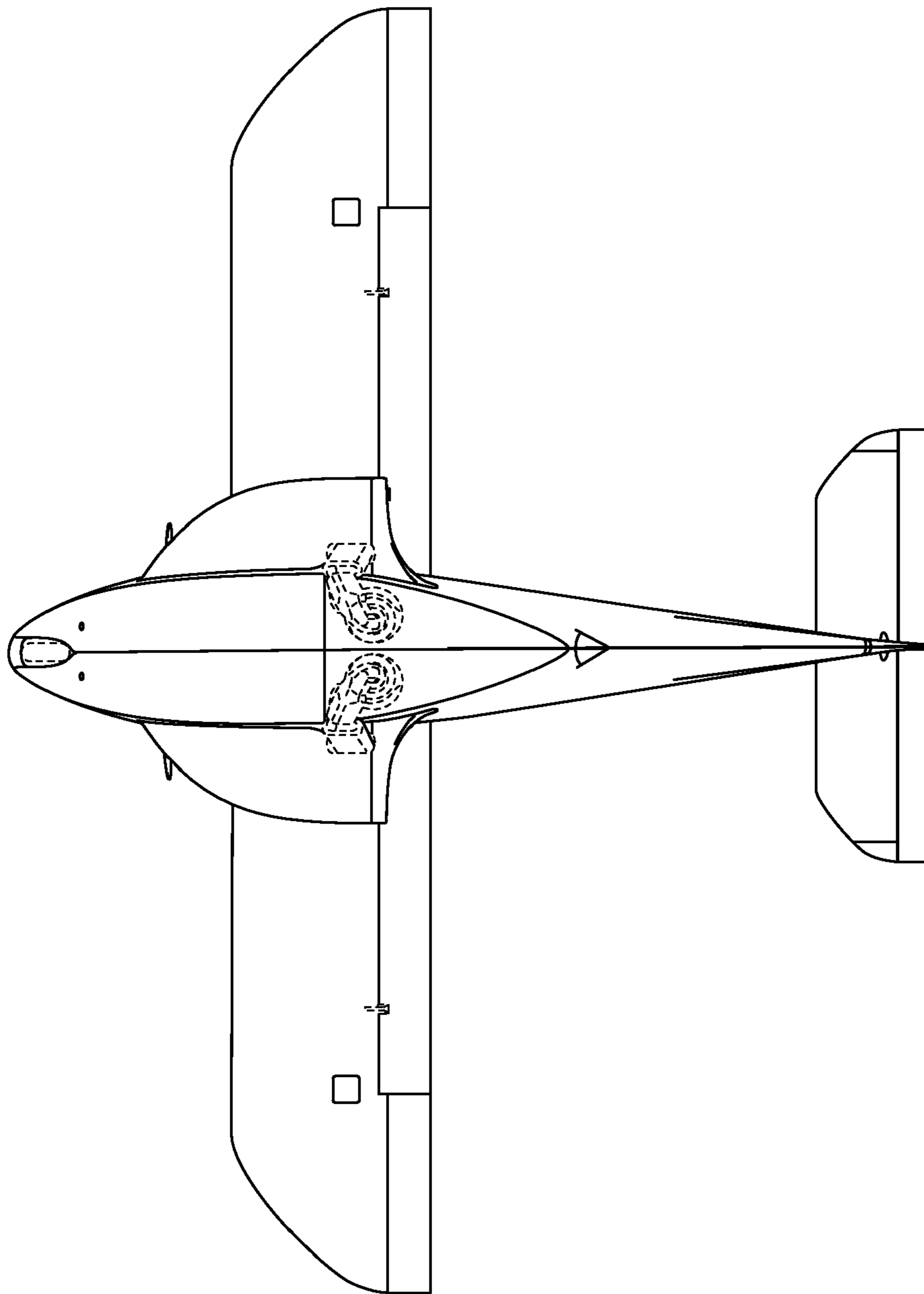

FIG. 7